

Tektronix[®]
COMMITTED TO EXCELLENCE

**PG 506
CALIBRATION
GENERATOR**

(SN B040000 AND UP)

INSTRUCTION MANUAL



**PLEASE CHECK FOR CHANGE INFORMATION
AT THE REAR OF THIS MANUAL.**

**PG 506
CALIBRATION
GENERATOR
(SN B040000 AND UP)**

INSTRUCTION MANUAL

**Tektronix, Inc.
P.O. Box 500
Beaverton, Oregon 97077**

070-3383-00
Product Group 75

Serial Number _____

First Printing NOV 1980
Revised APR 1984

Copyright © 1980 Tektronix, Inc. All rights reserved.
Contents of this publication may not be reproduced in any
form without the written permission of Tektronix, Inc.

Products of Tektronix, Inc. and its subsidiaries are covered
by U.S. and foreign patents and/or pending patents.

TEKTRONIX, TEK, SCOPE-MOBILE, and  are
registered trademarks of Tektronix, Inc. TELEQUIPMENT
is a registered trademark of Tektronix U.K. Limited.

Printed in U.S.A. Specification and price change privileges
are reserved.

INSTRUMENT SERIAL NUMBERS

Each instrument has a serial number on a panel insert, tag,
or stamped on the chassis. The first number or letter
designates the country of manufacture. The last five digits
of the serial number are assigned sequentially and are
unique to each instrument. Those manufactured in the
United States have six unique digits. The country of
manufacture is identified as follows:

B000000	Tektronix, Inc., Beaverton, Oregon, USA
100000	Tektronix Guernsey, Ltd., Channel Islands
200000	Tektronix United Kingdom, Ltd., London
300000	Sony/Tektronix, Japan
700000	Tektronix Holland, NV, Heerenveen, The Netherlands

TABLE OF CONTENTS

	Page
LIST OF ILLUSTRATIONS	ii
LIST OF TABLES	
Section 1 Specification	1-1
Section 2 Operating Instructions	2-1
<div style="border: 1px solid black; padding: 2px; display: inline-block; margin: 10px 0;">WARNING</div>	
<p><i>THE FOLLOWING SERVICE INSTRUCTIONS ARE FOR USE BY QUALIFIED PERSONNEL ONLY. TO AVOID PERSONAL INJURY, DO NOT PERFORM ANY SERVICING OTHER THAN THAT CONTAINED IN OPERATING INSTRUCTIONS UNLESS YOU ARE QUALIFIED TO DO SO.</i></p>	
Section 3 Theory of Operation	3-1
Section 4 Calibration Procedure	4-1
Performance Check	4-3
Adjustment Procedure	4-12
Section 5 Maintenance	5-1
Section 6 Options	6-1
Section 7 Replaceable Electrical Parts	7-1
Section 8 Diagrams and Illustrations	8-1
Section 9 Replaceable Mechanical Parts	9-1

LIST OF ILLUSTRATIONS

Fig. No.		Page
	PG 506 Calibration Generator	vi
2-1	Plug-in installation and removal	2-2
2-2	PG 506 controls and connectors	2-3
2-3	Output signals from the PG 506 Calibration Generator	2-6
2-4	Risetime derating graph	2-7
2-5	Typical waveforms showing correct and incorrect compensation adjustments . . .	2-8
2-6	Typical low frequency response curve . .	2-9
2-7	Distortion of square waves caused by low frequency effects	2-9
2-8	Typical waveform showing ringing at front corner	2-9
3-1	DVM timing diagram for a negative input to the integrator U460	3-4
4-1	Attenuator connections for current source	4-4
4-2	Typical response curve of sampling system	4-9
4-3	Typical sampling oscilloscope response display	4-10
4-4	Typical sampling oscilloscope response display	4-10
4-5	Adjustment locations for the A1 Main circuit board	4-13
4-6	Adjustment locations for the A2 DVM/Period circuit board	4-14
4-7	Adjustment locations for the A3 Fast Rise Output circuit board	4-16
4-8	Typical response curve as displayed on the sampling system	4-17
4-9	Typical response curve as displayed on the sampling oscilloscope	4-17
5-1	Pin assignments for the PG 506 (rear view, partial)	5-3
5-2	Main interface board (partial) showing amplitude and trigger output cable connections	5-4

LIST OF TABLES

Table No.		Page
1-1	Electrical Characteristics	1-1
1-2	Environmental Characteristics	1-3
1-3	Physical Characteristics	1-3
2-1	Output Load Vs. Voltage Out	2-5
4-1	Test Equipment Required	4-1
4-2	Standard Amplitude (into 1 M Ω) Within 0.25%, $\pm 1 \mu V$	4-3
4-3	100 V dc Range DEFLECTION ERROR % Resolution Tolerances	4-5
4-4	10 V dc Range DEFLECTION ERROR % Resolution Tolerances	4-5
4-5	Standard Amplitude into a 50 Ω Load . .	4-5
4-6	Fast Rise and High Amplitude Output Period	4-7
5-1	Selected Component Criteria	5-1
5-2	Relative Susceptibility to Static Discharge Damage	5-5

OPERATORS SAFETY SUMMARY

The general safety information in this part of the summary is for both operating and servicing personnel. Specific warnings and cautions will be found throughout the manual where they apply, but may not appear in this summary.

TERMS

In This Manual

CAUTION statements identify conditions or practices that could result in damage to the equipment or other property.

WARNING statements identify conditions or practices that could result in personal injury or loss of life.

As Marked on Equipment

CAUTION indicates a personal injury hazard not immediately accessible as one reads the marking, or a hazard to property including the equipment itself.

DANGER indicates a personal injury hazard immediately accessible as one reads the marking.

SYMBOLS

In This Manual



This symbol indicates where applicable cautionary or other information is to be found.

As Marked on Equipment



DANGER — High voltage.



Protective ground (earth) terminal.



ATTENTION — refer to manual.

Power Source

This product is intended to operate from a power source that will not apply more than 250 volts rms between the

supply conductors or between either supply conductor and ground. A protective ground connection by way of the grounding conductor in the power cord is essential for safe operation.

Grounding the Product

This product is grounded through the grounding conductor of the power cord. To avoid electrical shock, plug the power cord into a properly wired receptacle before connecting to the product input or output terminals. A protective ground connection by way of the grounding conductor in the power cord is essential for safe operation.

Danger Arising From Loss of Ground

Upon loss of the protective-ground connection, all accessible conductive parts (including knobs and controls that may appear to be insulating) can render an electric shock.

Use the Proper Fuse

To avoid fire hazard, use only the fuse of correct type, voltage rating and current rating as specified in the parts list for your product.

Refer fuse replacement to qualified service personnel.

Do Not Operate in Explosive Atmospheres

To avoid explosion, do not operate this product in an explosive atmosphere unless it has been specifically certified for such operation.

Do Not Operate Without Covers (for TM 500 plug-ins only)

To avoid personal injury, do not operate this product without covers or panels installed. Do not apply power to the plug-in via a plug-in extender.

SERVICE SAFETY SUMMARY

FOR QUALIFIED SERVICE PERSONNEL ONLY

Refer also to the preceding Operators Safety Summary.

Do Not Service Alone

Do not perform internal service or adjustment of this product unless another person capable of rendering first aid and resuscitation is present.

Use Care When Servicing With Power On

Dangerous voltages exist at several points in this product. To avoid personal injury, do not touch exposed connections and components while power is on.

Disconnect power before removing protective panels, soldering, or replacing components.

Power Source

This product is intended to operate from a power source that will not apply more than 250 volts rms between the supply conductors or between either supply conductor and ground. A protective ground connection by way of the grounding conductor in the power cord is essential for safe operation.



1740-01

PG 506 Calibration Generator

SPECIFICATION

Performance Conditions

The electrical characteristics are valid only if the PG 506 has been calibrated at an ambient temperature between +20°C and +30°C and is operating at an ambient temperature between 0°C and +50°C. Forced air circulation is required for ambient temperatures above +40°C.

Items listed in the Performance Requirements column of the Electrical Characteristics are verified by completing the Performance Check in the Service Section of this manual. Items listed in the Supplemental Information column are not verified in this manual. They are either explanatory notes or performance characteristics for which no limits are specified.

SPECIFICATION

Table 1-1

ELECTRICAL CHARACTERISTICS

Characteristics	Performance Requirements	Supplemental Information
STANDARD AMPLITUDE OUTPUT		
Range (Peak-to-Peak)		
1 M Ω Load	200 μ V to 100 V	
Accuracy	Within 0.25% \pm 1 μ V	
50 Ω Load	100 μ V to 5 V	
Accuracy	Within 0.25% \pm 1 μ V	
Period		Approximately 1 ms (1 kHz square wave, chopped DC)
Deflection Error Readout		
Range	+ and - 7.5%	
Resolution	Within 0.1%	
HIGH AMPLITUDE OUTPUT		
Amplitude (Peak-to-Peak)		
Unterminated	\leq 6 V to \geq 60 V	
50 Ω Load	\leq 0.5 V to \geq 5 V	
Polarity		Positive, measured from a negative potential to ground.

Table 1-1 (cont)

Characteristics	Performance Requirements	Supplemental Information
600 Ω Output Resistance	Within 5%	
Output Period		
1 μs to 10 ms	Within 5%	
Variable		Extends output period to at least 100 ms. X1 to greater than X10 range for each decade step.
Duty Cycle		Approximately 50%.
Rise Time		
Unterminated	≤100 ns	
50 Ω Load	≤10 ns	
Leading Edge Aberrations during first 50 ns	Within 2% of signal peak-to-peak amplitude, or 50 mV, whichever is greater.	
FAST RISE OUTPUTS		
Amplitude (Peak-to-Peak)		
50 Ω Load	≤100 mV to >1 V	
Polarity		Simultaneous positive and negative. Positive is measured from a negative potential to ground. Negative is measured from a positive potential to ground.
Output Resistance, 50 Ω	Within 3%	At either Fast Rise connector.
Risetime, 50 Ω Load	≤1 ns	
Leading Edge Aberrations, first 10 ns	Within 2% of signal peak-to-peak amplitude, or 10 mV, whichever is greater.	
Flatness	Within 0.5% after first 10 ns	
Output Period	1 μs to 10 ms	In decade steps.
Accuracy	Within 5%	
Variable		Extends output period to >100 ms. X1 to greater than X10 range for each decade step.
Duty Cycle		Approximately 50%.
TRIGGER OUTPUT		
+Trigger Out	≥1 V peak-to-peak into a 50 Ω load. Fixed amplitude.	Trigger out function available for HIGH AMPL and FAST RISE modes. Output signal leads HIGH AMPL pulse by about 18 ns and leads FAST RISE pulse by about 8 ns.

Table 1-2
ENVIRONMENTAL CHARACTERISTICS

Characteristics	Information
Temperature	Test to procedures of MIL-STD-810C Methods 502.1 and 501.1 using Procedure I as specified in MIL-T-28800B paragraph 4.5.5.1.3 and 4.5.5.1.4.
Operating	0°C to +50°C.
Non-operating	-55°C to +75°C.
Humidity	
Operating	+50°C to 95% relative humidity.
Non-operating	+60°C to 95% relative humidity. Test to MIL-STD-810C Method 507.1 Procedure IV, modified as specified in MIL-T-28800B paragraph 4.5.5.1.1.2.
Altitude	Test to MIL-STD-810C Method 500.1 Procedure I as specified in MIL-T-28800B paragraph 4.5.5.2.
Operating	To 15,000 feet.
Non-operating	To 50,000 feet.
Vibration	
Operating and Non-operating	With the instrument operating, the vibration frequency is swept from 10 to 55 to 10 Hz. Vibrate 15 minutes in each of the three major axes at 0.015" total displacement. Hold 10 minutes at any major resonance, or if none, at 55 Hz. Total time, 75 minutes.
Shock	
Non-operating	30 g's 1/2 sine, 11 ms duration, 3 shocks in each direction along 3 major axes, for a total of 18 shocks.
Transportation	Qualified under National Safe Transmit Committee Test Procedure 1 A, Category II.

Table 1-3
PHYSICAL CHARACTERISTICS

Characteristics	Information
Maximum Overall Dimensions	
Height	4.969 inches (12.621 cm).
Width	2.638 inches (6.701 cm).
Length	12.088 inches (30.704 cm).
Front Panel	
Finish	Anodized aluminum.
Net Weight	≈2 lbs. 4 oz. (1.02 kg).

OPERATING INSTRUCTIONS

INTRODUCTION

Description

The PG 506 Calibration Generator is designed to operate in a TM 500 Series Power Module. The instrument is a combination Amplitude Calibrator and Square Wave Pulse Generator intended for calibration and adjustments of oscilloscope amplifier systems with a 50 Ω or 1 M Ω input resistance.

The Amplitude Calibrator function provides either a + dc voltage or a 1 kHz square-wave output, as selected by an internal switch. Peak-to-peak amplitudes from 0.2 mV to 100 V across a 1 M Ω load and amplitude of 100 mV to 5 V across a 50 Ω load are available. Output amplitudes are selected in a 1,2,5 sequence.

Because errors are often stated as a percentage, an internal digital differential voltmeter with front-panel light-emitting diode (LED) readout is used to provide a display equal to oscilloscope vertical or horizontal deflection errors. If the indicated deflection on an oscilloscope graticule does not agree with the proper reference line, the output amplitude from the PG 506 Amplitude Calibrator can be varied until the proper alignment is obtained. In this operating mode, the front-panel readout is a direct display of the oscilloscope deflection error.

A 5 mA Current Loop is provided, which supplies current (dc or 1 kHz) for calibration of current probes.

The Pulse Generator provides three square-wave outputs: variable High Amplitude pulses and simultaneous positive and negative-going Fast Rise, variable-amplitude pulses. In the Pulse Generator mode, the Period is selectable from 1 μ s to 10 ms in decade steps. A variable control extends the maximum period to at least 100 ms (for each decade step, the period is variable over a 10:1 range). A positive going pretrigger output is also provided for triggering external equipment.

Installation and Removal

CAUTION

Turn the power module off before inserting the plug-in; otherwise, damage may occur to the plug-in circuitry. Because of the high current drawn by the PG 506, it is also recommended that the power module be turned off before removing the PG 506. Refer to Fig. 2-1. Check to see that the plastic barriers on the interconnecting jack of the selected power module compartment match the cut-outs in the PG 506 circuit board rear edge connector.

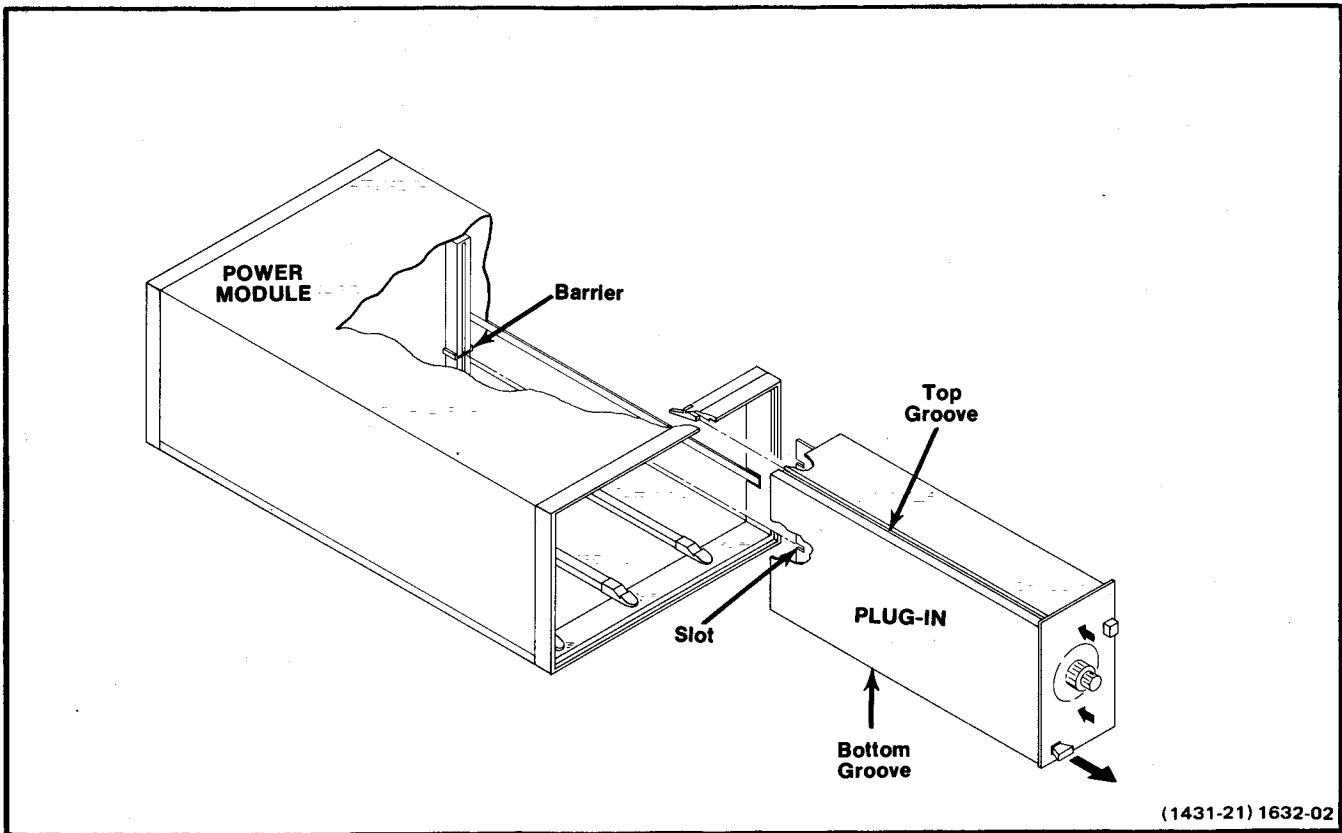

Fig. 2-1. Plug-in installation and removal.

CONTROLS AND CONNECTORS

- ① DEFLECTION ERROR %: A direct display of output amplitude deflection error.
- ② AMPLITUDE: Selects calibrated output amplitudes across 1 M Ω or 50 Ω load attached to AMPL OUTPUT (STD) connector.
- ③ VARIABLE (OUT): When released, operates in the standard amplitude mode. The deflection error readout indicates the error in percentages with 0.1% resolution.
- ④ PERIOD light: Illuminated when the function switch is in Fast Rise or High Ampl mode.
- ⑤ PERIOD: Selects the period of either the Fast Rise or High Ampl square-wave signals.
- ⑥ VAR: Extends the period range 10:1. The calibrated position is counterclockwise.
- ⑦ +TRIG OUT: Provides a signal source to pretrigger external equipment.
- ⑧ FAST RISE OUTPUTS: Provides for simultaneous positive and negative going square-waves as selected by the PERIOD/VAR controls.
- ⑨ Function switch: Determines whether the instrument is operated in STD AMPL, HIGH AMPL, or FAST RISE mode.
- ⑩ PULSE AMPLITUDE: Controls output amplitude in the High Amplitude or Fast Rise modes.
- ⑪ AMPL OUTPUT HIGH or STD: Common output for High Amplitude or Standard Amplitude modes. 1 kHz square-wave or dc for Standard amplitude. Period of the High Amplitude square-wave is set by the Period controls.
- ⑫ Current Loop: A dc or 1 kHz square-wave 5 mA current supply for calibration of current probes. The

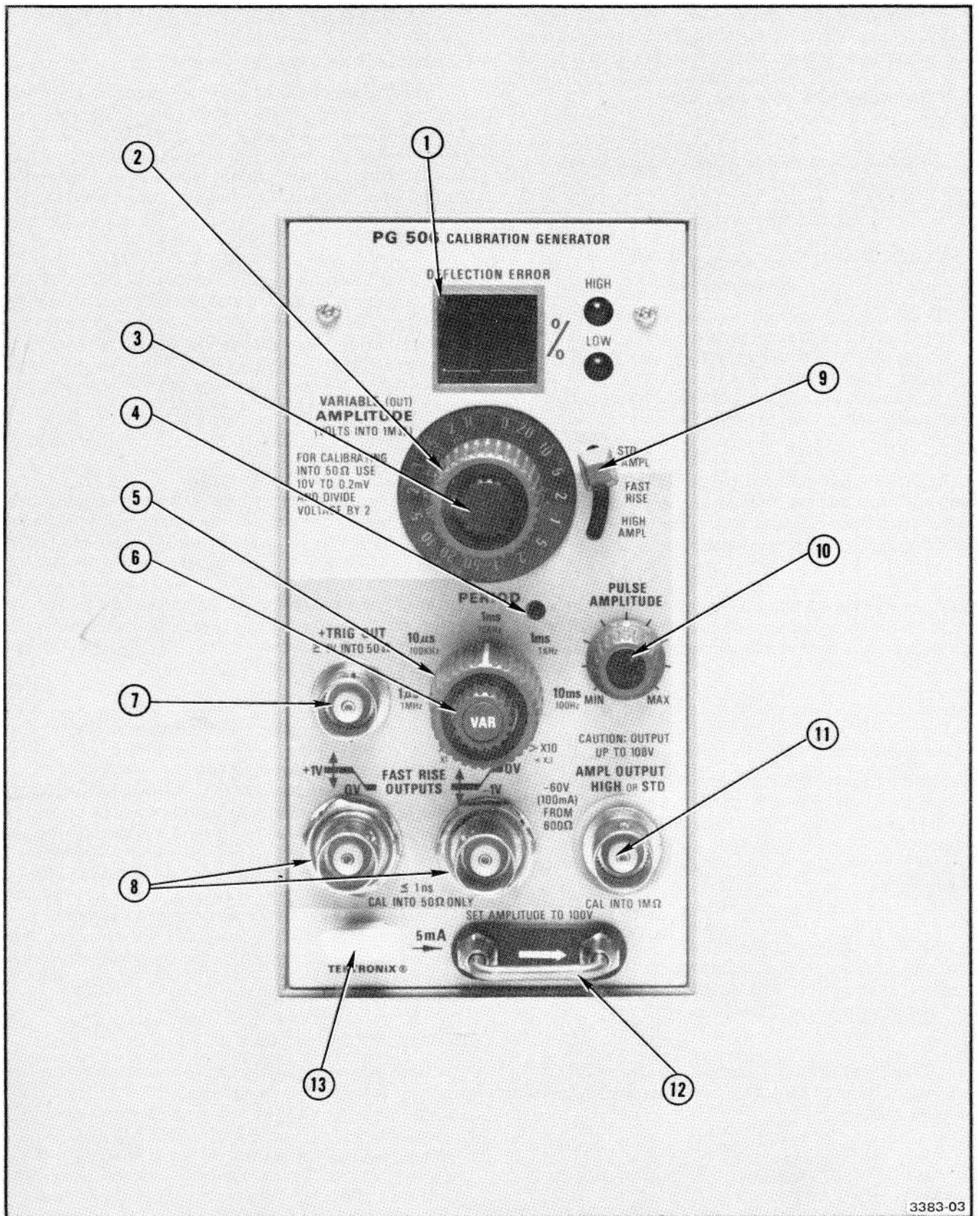

Fig. 2-2. PG 506 controls and connectors.

VARIABLE (OUT) control will vary current through the loop, but DEFLECTION ERROR readout is not directly related to current deviations. The DEFLECTION ERROR readout must be off or adjusted to read 0.0% for a calibrated output.

Release Latch: Pull to remove the instrument from the power module.

WARNING

Dangerous voltage may be present on the front-panel BNC connector labeled AMPL OUTPUT (HIGH or STD). Before installation, turn the control labeled AMPLITUDE (VOLTS INTO 1 M Ω) fully counterclockwise (ccw) and the control labeled PULSE AMPLITUDE to MIN.

Align the upper and lower groove of the PG 506 chassis with the upper and lower guides of the selected compartment. Push the module in and press firmly to seat the circuit board in the interconnecting jack.

To remove the PG 506, pull on the release latch located in the lower left corner until the interconnecting jack disengages and the PG 506 will slide out.

Preliminary Checks

Make all desired connections to equipment under test before applying power to the PG 506. The power switch is on the Power Module. Power application to the PG 506 is indicated by the PERIOD light turning on, or the light behind the knob skirt of the AMPLITUDE control switch being lighted.

The front-panel LED can be tested (888 display) by setting the three-position Mode switch to STD AMPL position, then pushing and holding the VARIABLE knob concentric with the AMPLITUDE switch.

To test the digital voltmeter system, release the VARIABLE knob to the out position and rotate the control in both directions.

Allow 15 to 20 minutes warmup time for all equipment before using the PG 506.

AMPLITUDE CALIBRATOR MODE

Connections and Terminations

To use the PG 506 Amplitude Calibrator system, set the mode switch to the STD AMPL position. Connect the 1 kHz calibrated amplitude signal at the AMPL OUTPUT connector to the input of an oscilloscope through a coaxial cable that has a 50 Ω characteristic impedance (RG-58/U) with a maximum length of 42 inches (shorter cables can be used).

With a cable termination of 1 M Ω and the DEFLECTION ERROR display off, the 1 kHz signal peak-to-peak output amplitude will be equal to the indicated reading on the AMPLITUDE switch. If the cable is terminated into a 50 Ω load, use an output amplitude in the 10 V to 0.2 mV range; the output amplitude will then be one-half the indicated reading on the AMPLITUDE switch.

Oscilloscope Controls

The deflection factor (either vertical or horizontal) for oscilloscopes is the ratio of the amplitude of the input signal to the amount of beam deflection produced on the cathode-ray tube (crt), usually stated as volts per division of deflection (Volts/Div). Calibration procedures for some oscilloscopes require that the gain be set and the deflection accuracy be checked with a probe (properly compensated) connected between the PG 506 and the oscilloscope input connector.

For oscilloscope gain adjustments and checking of deflection accuracies, it is always best to set all oscilloscope controls exactly as called out in the calibration and performance sections of the oscilloscope instruction manual. However, it may be found desirable to set the oscilloscope sweep controls to a 0.1 ms/div (or faster) sweep rate and free-run the sweep when performing vertical deflection (amplitude) checks and adjustments. This procedure produces two horizontal traces that are separated vertically by an amount proportional to the peak-to-peak amplitude of the 1 kHz square-wave from the PG 506. At faster sweep rates, the display becomes more readable.

Deflection Error Readout

When performing gain adjustments on oscilloscope or amplifier systems, it is mandatory that the DEFLECTION ERROR readout be turned off in order to obtain calibrated output amplitudes. The PG 506 DEFLECTION ERROR readout feature finds its greatest use in its ability to allow an operator to verify the oscilloscope deflection accuracy associated with amplifier gain and input attenuators.

Gain adjustments for oscilloscope amplifiers are usually made at low levels, for example; at a 10 mV/div deflection factor and a 50 mV signal from the PG 506. This ratio corresponds to five major graticule divisions of beam deflection. If the gain of the oscilloscope amplifier system is low, the indicated deflection will be less than five major graticule divisions, for example; 4.8 major division. The VARIABLE AMPLITUDE (OUT) control on the PG 506 can then be used to increase the output amplitude until the total deflection is exactly five major divisions. At this point, the DEFLECTION ERROR readout will read 4.0% LOW. Conversely, if the oscilloscope amplifier system gain is too high, the indicated deflection on the crt will be above the proper reference line, for example; 5.2 major divisions. Using the VARIABLE AMPLITUDE control on the PG 506 to reduce the output amplitude for exactly five major divisions of deflection will produce a DEFLECTION ERROR readout of 4.0% HIGH.

For some oscilloscopes the deflection factor may not be constant throughout the full vertical dimensions of the graticule, due to compression or expansion nonlinearities. To check for this type of nonlinearity; center a two-division display, then position the display to the top of the graticule. Measure any deflection errors with the PG 506 VARIABLE AMPLITUDE control. Next, position the two-division display to the bottom of the graticule and measure the deflection errors. These nonlinearities should be taken into account when making measurements with full graticule deflection, or with the crt trace positioned towards the top or bottom graticule limits and using small deflection factors.

Current Loop

One end of the Current Loop is grounded and terminates a precision voltage divider. The direction of the arrow is oriented for conventional current. To obtain a calibrated 5 mA from the Current Loop, set the mode switch to STD AMPL position and the AMPLITUDE control switch to the 100 V position. The DEFLECTION ERROR readout should be off, or adjusted to read 0.0%. The current signal can be either dc or 1 kHz square-wave current, as selected by an internal switch.

PULSE GENERATOR MODE

General

In order to ensure waveform fidelity when using the Pulse Generator function of the PG 506, the following precautions should be observed.

1. Use high quality 50 Ω coaxial cable, connectors, and terminations (where applicable). Make all connections as tight and short as possible.

2. Reduce capacitive and inductive loads to a minimum. Risetime degradation occurs with long cable lengths.

3. Minimum risetime and pulse aberrations are obtained with 50 Ω loads and loads must be capable of dissipating the power available at any output connector in any operating mode.

4. The external equipment is assumed to have no dc voltage across the load to which the PG 506 is connected. If a dc voltage exists, the output amplitude from the PG 506 will be in error by the amount of the dc offset. To prevent dc-offset errors, couple the PG 506 outputs through a dc blocking capacitor to the load. The time constant of the coupling capacitor and the total resistance in series must be long enough to maintain pulse flatness.

High Amplitude Output

To use the PG 506 Pulse Generator system to produce high amplitude square-waves, set the mode switch to HIGH AMPL position and connect external equipment to the AMPL OUTPUT HIGH connector. Set the Period controls for the period or frequency desired. The output amplitude of this signal can be adjusted with the PULSE AMPLITUDE control.

This signal can be used to adjust oscilloscope amplifier input capacitance, attenuator compensation networks, and other internal frequency compensation networks. The AMPL OUTPUT HIGH signal is negative with respect to ground, with its risetime related to the rising portion (from a negative potential) of the waveform. Refer to Fig. 2-3. The absolute peak-to-peak value of the square-wave is determined by the load resistance and the setting of the PULSE AMPLITUDE control. Table 2-1 lists the *typical amplitudes* available when the PG 506 is terminated into three different load resistances.

Table 2-1

OUTPUT LOAD VS. VOLTAGE OUT

HIGH AMPL OUTPUT Termination	PULSE AMPLITUDE Control ¹	
	MIN	MAX
50 Ω Load	0.3 V p-p	5.2 V p-p
600 Ω Load	1.9 V p-p	32.5 V p-p
1 M Ω Load	3.8 V p-p	≥ 60.0 V p-p

¹ Approximate amplitudes.

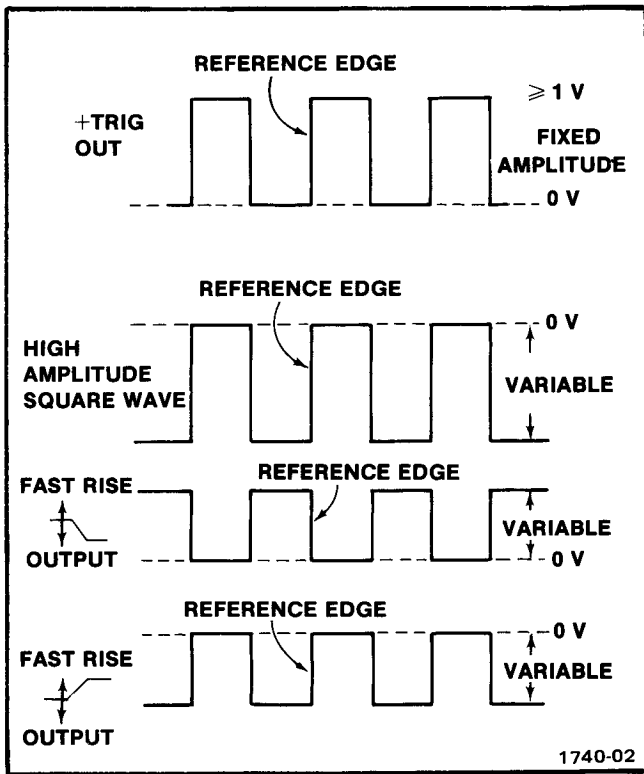

Fig. 2-3. Output signals from the PG 506 Calibration Generator.

Fast Rise Outputs

To use the PG 506 Pulse Generator system to produce low amplitude, fast-rise square-waves, set the mode switch to FAST RISE position and connect external equipment to the FAST RISE OUTPUTS connector(s). Set the PERIOD controls for the period or frequency desired. The output amplitude can be adjusted by the PULSE AMPLITUDE control.

These signals are usually used to adjust high-frequency compensation networks in oscilloscope amplifier circuits. The adjustments are made for optimum response (minimum aberrations). The risetime and amplitude specifications for the FAST RISE outputs apply only when they are terminated into a 50 Ω load. Larger amplitudes (greater than 1 V peak-to-peak) can be obtained from these output connectors under unterminated conditions, but the risetime specification is no longer applicable.

GENERAL INFORMATION

Risetime Considerations

The PG 506 can be used in conjunction with an oscilloscope to determine the risetime of a device under test. Risetime is normally measured (unless otherwise specified) between the 10% and 90% amplitude levels on

the leading edge of a waveform. The risetime of a displayed waveform is illustrated in Fig. 2-4.

Before measuring the risetime of a device under test, the combined risetime of the PG 506 output signal and the oscilloscope vertical amplifier system must be known. Refer to Fig. 2-4 for the percentage error to be expected when the two devices are cascaded. Sweep timing accuracy should be verified before any risetime measurements are made. Inaccuracies in the sweep timing and display reading errors must be added algebraically to the percentage error obtained from computations related to Fig. 2-4.

The graph for Fig. 2-4 can be used as a guideline for the following general conclusions.

1. Oscilloscopes should have a vertical system risetime about one-seventh of the fastest signal applied to keep system errors to a minimum.
2. Conversely, if the signal risetime is at least seven times faster than the risetime of the oscilloscope vertical system, the displayed (observed) waveform will have a risetime that is very close to the risetime of the vertical system.

3. The displayed risetime as observed on any oscilloscope can never be faster than the risetime of the slowest device in the system.

Risetime of a displayed waveform is related to total system bandwidth. A system with limited high-frequency response will produce a displayed risetime that is slower than expected. If a fast-step signal produces a crt display with little or no overshoot or ringing, the product of oscilloscope risetime and oscilloscope bandwidth should result in a factor whose value lies between 0.329 and 0.350.

The following steps describe the procedure to follow in determining the risetime of a device under test.

1. Connect the appropriate output signal from the PG 506 to the oscilloscope vertical input with a short 50 Ω coaxial cable terminated into a 50 Ω load.

2. Set the oscilloscope controls to display the leading edge of the waveform. Risetime measurements should be made over the largest part of the graticule area possible. When the fastest sweep rate is relatively slow compared with the vertical system risetime (or the scale is small), measurements become confined to small sections of the graticule, and the probability of display reading errors becomes greater.

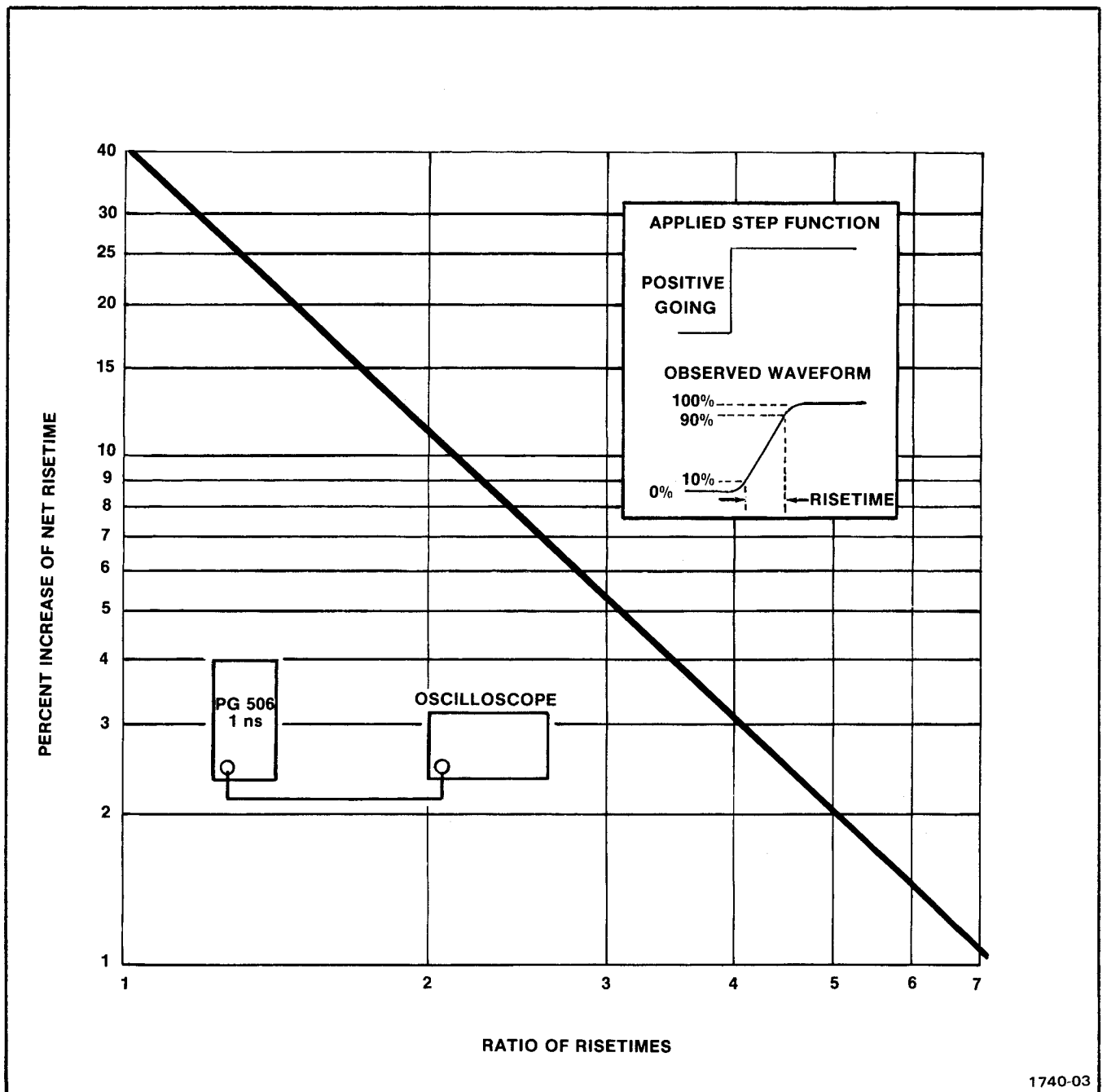

1740-03

Fig. 2-4. Risetime derating graph.

3. Measure the time duration between the 10% and 90% amplitude levels. This is the combined risetime of the PG 506 and the oscilloscope (T_{rc}).

4. Disconnect the coaxial cable and 50 Ω termination from the oscilloscope.

5. Connect the coaxial cable from the PG 506 to the input of the device under test and connect the output of

the device under test to the oscilloscope vertical input. Terminate the device under test in its characteristics impedance for optimum performance.

6. Set the oscilloscope controls to display the leading edge of the displayed waveform and measure the time duration between the 10% and 90% amplitude levels (over the same graticule area, if possible). This is the total system risetime (T_{rs}).

Operating Instructions—PG 506 (SN B040000 & up)

7. Calculate the risetime of the device under test (dut) using the following formula:

$$T_r (\text{dut}) = (T_n)^2 - (T_{rc})^2 \quad 1/2$$

Checking Amplifier Response

The square-wave output signals from the PG 506 can be used to check the response of active or passive systems. Because the characteristics of a pulse from the PG 506 is known (see ELECTRICAL CHARACTERISTICS), distortion of the waveform beyond these limits is due to the device under test.

The compensation of an ac-voltage divider, such as used in the input attenuator of an oscilloscope or a passive attenuator probe, can be checked by observing its response when a square-wave signal is applied. Correct response is shown by optimum square corner on the displayed waveform. If the waveform has overshoot, rolloff, or front-corner rounding, the system is not correctly compensated. Figure 2-5 shows typical waveforms illustrating correct and incorrect compensation adjustments. When performing these compensation checks, the repetition rate of the applied square-wave signal should be at least 3 to 4 decades above the low-frequency cutoff point (frequency where the equivalent sine-wave amplitude is 30% down).

The low end cut-off frequency (due to RC coupling) for an amplifier can be approximated very closely by using the following procedure.

1. Apply a square-wave at a repetition rate that is not affected by the low-frequency limit.
2. Slowly reduce the square-wave frequency and adjust the oscilloscope (amplifier) controls to display a signal similar to Fig. 2-6.
3. Determine the ratio between the amplitude levels, V_1 and V_2 . Note that V_1 and V_2 are peak values above the zero-volt reference level.
4. The equivalent RC product can be determined by using the following formula; where F_a is the applied frequency for a given ratio of V_1/V_2 (greater than unity).

$$\frac{1}{1 F_a \ln V_1/V_2} = RC \text{ (for square-waves only)}$$

5. Using the RC product obtained in step 4, calculate the low-end cut-off frequency.

$$F_L \text{ (3 dB)} = \frac{159 \times 10^{-3}}{RC}$$

For example; if the applied frequency, F_a , is 10 Hz and the amplitude values shown in Fig. 2-6 are used, the lower cut-off frequency is calculated to be about 1.6 Hz.

Figure 2-7 illustrates other waveform distortion effects that may be observed if amplifier circuits are not properly compensated for low frequencies.

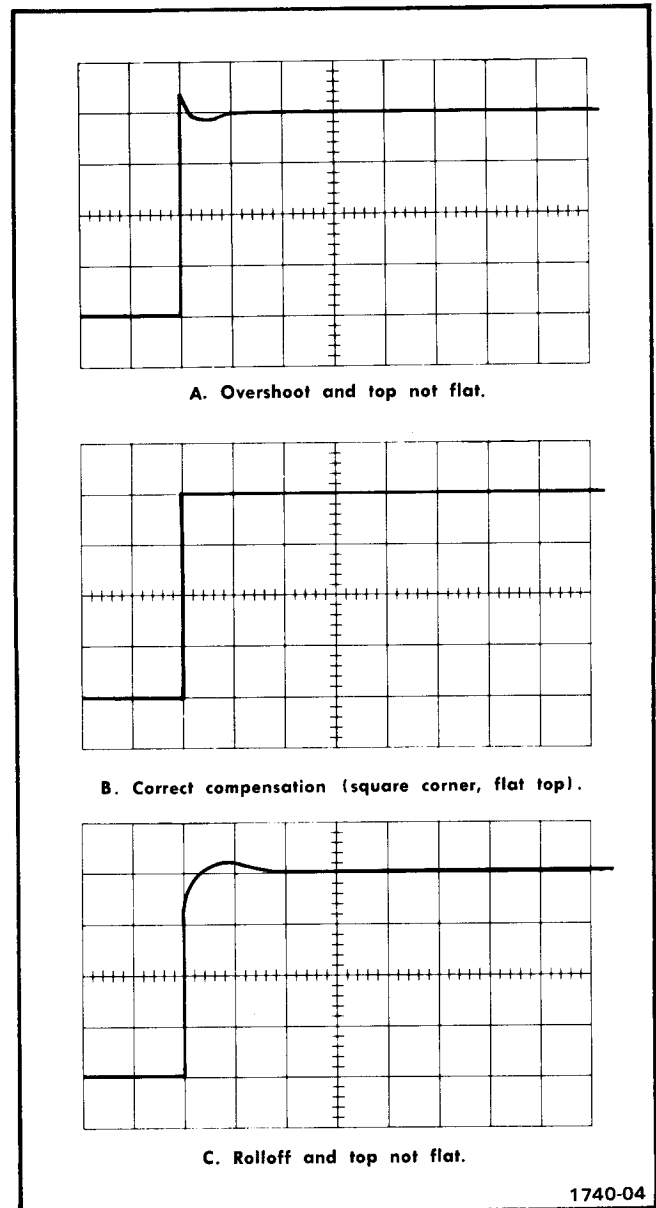

Fig. 2-5. Typical waveforms showing correct and incorrect compensation adjustments.

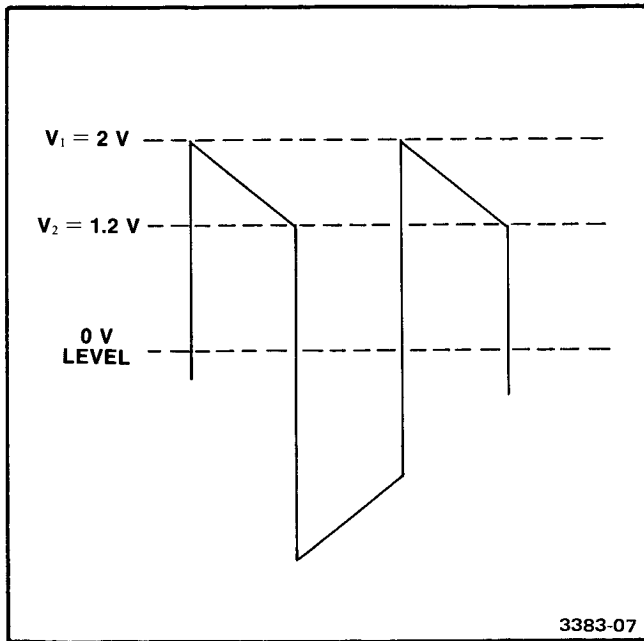

Fig. 2-6. Typical low frequency response curve.

Figure 2-8 illustrates waveform distortion due to incorrect high-frequency compensations. Ringing indicates incorrect peaking adjustments or undesired inductive effects, while excessive overshoot and rolloff indicates incorrect capacitive adjustments. Limited high-frequency response is also indicated by risetime measurements that are much slower than expected (see Risetime Considerations). Impedance mismatching will usually show up at excessive aberrations somewhere along the flat portion of the waveform.

Repackaging Information

If the Tektronix instrument is to be shipped to a Tektronix Service Center for service or repair, attach a tag showing the owner (with address) and the name of an individual at your firm that can be contacted. Include the complete instrument serial number and a description of the service required.

Save and re-use the package in which your instrument was shipped. If the original packaging is unfit for use or not available, repackage the instrument as follows:

Surround the instrument with polyethylene sheeting to protect the finish of the instrument. Obtain a carton of corrugated cardboard of the correct carton strength and having inside dimensions of no less than six inches more than the instrument dimensions. Cushion the instrument by tightly packing three inches of dunnage or urethane foam between carton and instrument on all sides. Seal the carton with shipping tape or an industrial stapler.

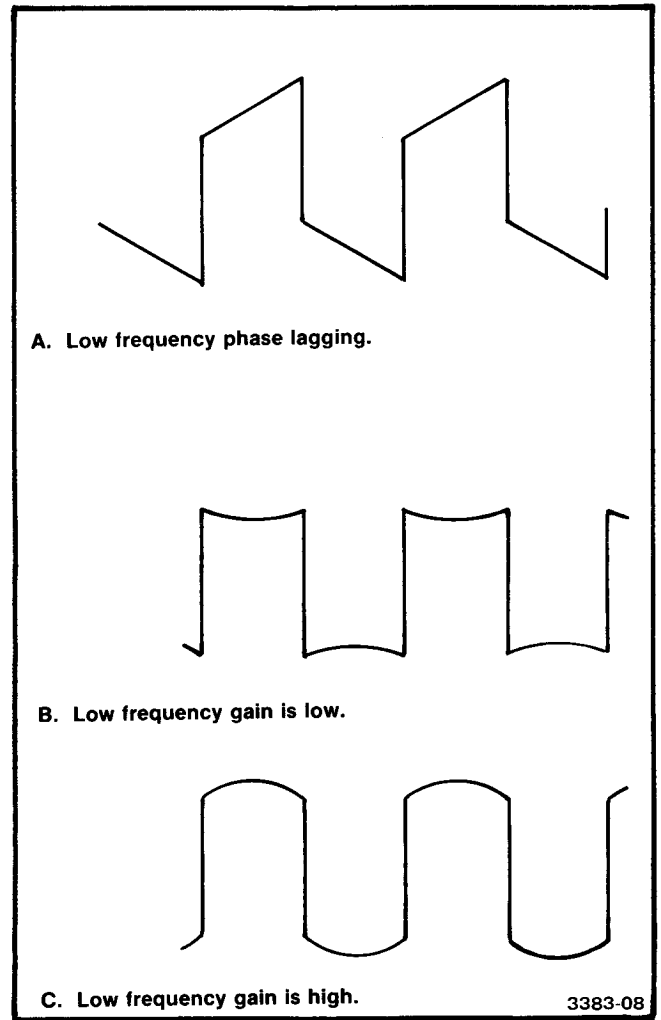

Fig. 2-7. Distortion of square waves caused by low frequency effects.

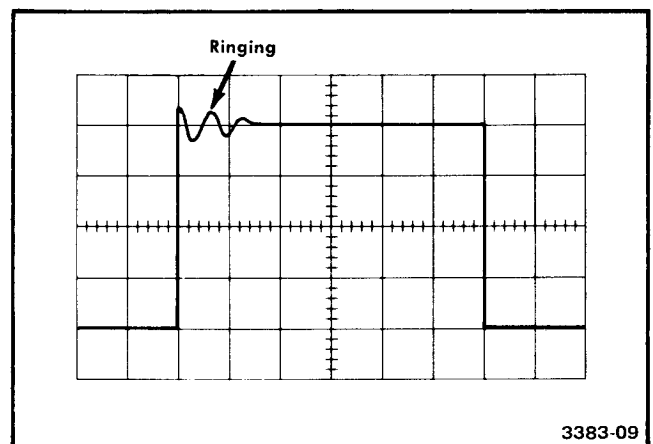

Fig. 2-8. Typical waveform showing ringing at front corner.

The carton test strength for this instrument is 200 pounds per square inch.

WARNING

THE FOLLOWING SERVICING INSTRUCTIONS ARE FOR USE BY QUALIFIED PERSONNEL ONLY. TO AVOID PERSONAL INJURY, DO NOT PERFORM ANY SERVICING OTHER THAN THAT CONTAINED IN OPERATING INSTRUCTIONS UNLESS YOU ARE QUALIFIED TO DO SO. REFER TO OPERATORS SAFETY SUMMARY AND SERVICE SAFETY SUMMARY PRIOR TO PERFORMING ANY SERVICE.

THEORY OF OPERATION

Primary Power

The 120 V dc supply is the main power source for the Standard Amplitude system.

The + and -16.5 V dc supply is the main power source for the Digital Voltmeter circuitry, the Fast Rise stages, and two operational amplifier circuits in the Standard Amplitude system.

The -72 V, variable dc supply is the main power source for the High Amplitude section. This supply can vary from about -10 V to about -72 V, dependent upon operating conditions.

All of the above dc supplies are produced by conventional full-wave bridge rectifier circuits that are driven by an inverter system that changes a dc voltage to approximately 25 kHz power in the primary and secondaries of T130. Each supply is switched on or off, dependent upon the operating modes.

The 5.2 V dc supply is derived from a 11.5 V dc source in the power module and is distributed mainly to the Period Generator, Counter circuits, and certain logic gates. This supply is also used as a return for the High Amplitude circuits.

CR10 and CR11, together with C10, convert 25 V ac (rms) from two transformer secondaries in the power module to about 35 V dc. VR10 sets and regulates the base voltage of emitter-follower Q15 to about 15 V, establishing a fixed 14 V supply for the 25 kHz free-running multivibrator (Q90-Q100).

The free-running multivibrator collector output has a peak-to-peak amplitude of about 5 V, and the positive swing is limited to about +5.8 V by CR86 and CR105. This signal drives the bases of Q85 and Q120 for the inverter system. The feedback connections from the collectors of Q80 and Q125, through CR80 and CR125, ensures that both transistors are never on at the same time.

The maximum voltage swing at the collectors of Q80 and Q125 is about twice the dc level established at the junction of L35 and C36 in any operating mode. For the High Amplitude mode, this dc level is dependent on the

setting of the PULSE AMPLITUDE control and the external load that terminates the PG 506. With a 1 M Ω (unterminated) load, the dc level will be about 3.5 V for the MIN position and about 20 V for the MAX position.

Remote voltage sensing to regulate the -72 V variable supply originates in the High Amplitude circuit and is applied through CR27 to pin 4 of voltage regulator U20.

When in the Standard Amplitude or Fast Rise mode, the junction of L35 and C36 is about 20 V dc, with the -72 V variable supply disconnected from the High Amplitude circuitry.

Voltage regulation for the Standard Amplitude and Fast Rise modes is dependent upon the peak voltage (about 10 V) developed across C75 by the half-wave rectifier action of CR78, which obtains its ac voltage from a sense winding of T130. The peak level across C75 is applied to a voltage divider composed of R31, R30, and R29. The quiescent level set on pin 4 of U20 by the adjustment of R30 determines the quiescent current through the NPN series-pass transistor. Pin 4 of U20 is the inverting input terminal for an internal comparator, and any voltage change on pin 4 causes a voltage change in the opposite direction on pin 10. A potential difference of 33.0 V across the + and -16.5 V supplies is accomplished by adjusting R30.

Current limiting for the 35 V dc input is controlled by the voltage drop across R22. If pin 2 of U20 goes about 0.6 V more positive than pin 3, pin 10 goes negative to limit current through the NPN series-pass transistor and the load. CR22 protects a transistor internal to U20. C22 frequency compensates the voltage regulator. VR30 is not normally on; it protects the supply from over-voltage conditions if the potential difference across it exceeds 12 V.

U20 sets its own reference voltage of about 7 V on pin 6, with pin 5 being the non-inverting input to an internal comparator. The reference voltage on pin 6 is divided down by R40 and R42 to set a reference level of 5.2 V on pin 2 of error amplifier U50.

Voltage regulation of the 5.2 V supply is accomplished by comparing the voltage level on pin 3 of U50 with the

Theory of Operation—PG 506 (SN B040000 & up)

voltage reference on pin 2. If the voltage on pin 3 is higher than the reference level, the output of U50 goes positive. This voltage increase is applied through emitter-follower Q60 to the base of the PNP series-pass transistor. This action decreases the current in the PNP series-pass transistor and the load, returning the 5.2 V supply to its original level.

VR55 and CR55 operate as current limiting control devices. The normal operating potential at the base of Q60 is about 9.2 V, with VR55 and CR55 not conducting. If the load current increases (due to lower load resistance), pin 3 of U50 goes negative. This drives the base of Q60 negative to about 8.3 V. The action is sufficient to cause VR55 and CR55 to conduct, clamping the emitter of Q60 and the base of the PNP series-pass transistor to about 9 V. R65 limits the load current to about 1.5 A.

An over-voltage condition of about 1 V on the 5.2 V supply causes VR45 to conduct, developing an SCR firing pulse across R45. If Q45 turns on, the output level is clamped to about 0.2 V.

Standard Amplitude

The Standard Amplitude system consists of two sections, a high-voltage section and a 50 Ω source section. Output amplitudes of 100 V, 50 V and 20 V originate directly from a precision voltage divider composed of R278, R277, R276, R275, and the 5 mA Current Loop. For these three output amplitudes, the input to the 50 Ω source section is disconnected and pin 2 of U375 is grounded through R380. With pin 2 of U375 grounded, its output locks the base of Q365 to +16 V, disabling the current drive for the 50 Ω source section.

The Primary Power section applies 120 V to the emitter of Q280, a 10 mA current source. This 10 mA is split between two branches containing matched diodes; 5 mA through CR280A and the precision divider and 5 mA through CR280B from the 100 V bus. In the dc mode, Q255 and Q270 are cut off (due to saturation of U255) and the quiescent level at the anodes of the matched diodes is about 100.7 V.

With S225 closed, (VARIABLE AMPLITUDE control pushed in and DEFLECTION ERROR readout off), a 100 V bus is established across a voltage divider composed of R237 and R234. The reference source for the 100 V bus originates with VR210, which produces a 9 V drop when drawing 7.5 mA through R210. The 9 V level across R210 also serves as a reference voltage for the Digital Voltmeter circuit.

When R205 has been adjusted to produce 100.0 V across an external 1 M Ω load, pins 2 and 3 of U200 will be

essentially at the same potential (9 V) and pin 6 of U200 is at a quiescent level of about 4 V. The emitter of Q190 will be at 18 V and this point serves as a regulated voltage source to power operational amplifiers in the 50 Ω source section. Because Q190 is included in the feedback loop around U200, the current through VR210 and R210 remains constant.

One mA through R237 and R234 sets a 9 V level on pin 2 of U240. Pin 3 of U240 is returned to the 9 V zener reference through R225A and R215. With almost equal potentials on each side of R225A, the current through this network is in the low mA range. R225A tracks with R225B and serves only as a variable Thevenin input impedance for the non-inverting input terminal of U240, which aids in stabilizing the offset bias current.

U240 and the circuitry associated with Q245 and Q290 operate as a voltage regulating circuit for the 100 V bus. Any voltage change on the 100 V bus is sensed across R237 (or through C237) and applied to pin 2 of U240. Q245 operates as a level shifter and signal inversion through Q290 returns the 100 V bus to its calibrated level. CR290 and CR291 operate to limit turn-on surge current through Q290.

When the VARIABLE AMPLITUDE control is released to the out position, R237 is disconnected from ground and R227 is inserted in series with R225B. The 100 V bus now becomes a variable level. R225B can adjust the 100 V bus over a range of approximately 92–108 V, and the regulating circuit will hold the selected level. The difference in potential between the adjustable level on the 100 V bus and the 9 V zener reference is applied to the Digital Voltmeter circuitry for DEFLECTION ERROR readout (100 V equals 0.0%).

When the 1 kHz (calibrated amplitude) mode is selected, a 1 kHz squarewave is applied to the base of Q270 through U255 and emitter follower Q255. The positive step on the base of Q270 saturates this transistor, pulling its collector below 0.4 V. This action disconnects CR280A and CR280B, allowing the voltage swing across the precision divider to start from ground and rise to the level selected on the variable bus when Q270 is cut off by the negative step of the 1 kHz signal.

The 50 Ω source section must drive either a 1 M Ω or 50 Ω external load resistance. This requirement is met by using a constant-current supply; which, by definition, will alter its output voltage by just the proper amount to maintain its total output current at a constant value when the load resistance changes. The 50 Ω source section operates only when amplitude settings of 10 V or lower are selected.

A nominal 14 V input to the 50 Ω source section is derived from the precision divider at the junction of R275 and R276 and applied to pin 2 of U375 (R380 is disconnected from ground). This input voltage will always be a dc level proportional to the dc level established on the 100 V bus. U375 and Q365 operate as a tracking voltage source. If the input to U375 changes by 5%, the collector voltage of Q365 changes by 5%.

The constant-current supply is programmed by current-setting resistors in series with the emitter of Q325 and the collector of Q365 to produce three selected output current levels through CR320. Selected calibrated currents of 200 mA, 100 mA, or 40 mA split between three branches consisting of R316, the symmetrical pi (ladder) attenuator network, and the external load. With R340 properly adjusted, three voltage levels (10 V, 5 V, or 2 V) can be selected to appear across R316 for an external termination of 1 M Ω . With an external termination of 50 Ω , the three selected levels across R316 will drop to 5 V, 2.5 V, or 1 V. Each section of the ladder attenuator divides by 10 and if the level across R316 is considered to be a 0 dB reference, the total attenuation is 80 dB (20 dB per section). The attenuator presents an output impedance of 50 Ω at any voltage take-off point.

Regulation for the constant-current supply is provided by the operational amplifier feedback connections from the current-setting resistors low level end through U330 to the base of Q326. Q320 is cut off for the dc mode and operates as a saturating switch for the 1 kHz mode.

Digital Voltmeter

The Digital Voltmeter circuitry is an analog-to-digital converter, that operates on the principle of a modified dual-slope integrating system. A change in input current to integrator U460 causes a ramp voltage to appear at pin 6. At a given time during the ramp, C462 is discharged by a reference current of opposite polarity. At the time the discharge current is applied, a counter is at a count of 200 (00). When the integrated waveform on pin 3 of differential comparator U470 (zero crossing detector) reaches zero, a number in the counter is stored. The accumulated counts are displayed as being proportional to the value of the input voltage applied; a higher input voltage means a longer time to zero crossing, thus a higher count. It takes a few cycles of dual-slope integration for the analog-to-digital converter system to settle down for a stable readout.

A non-linear reciprocal relationship exists between the Standard Amplitude output from the PG 506 and the actual deflection error of an oscilloscope amplifier system. Consequently, to indicate a deflection error that is 6.8% LOW, the output from the PG 506 must be adjusted to be 7.3% high (variable 100 V bus set to 107.3 V). For an

indicated deflection error of 7.3% HIGH, the variable 100 V bus must be adjusted for 93.2 V. It is the voltage changes on the variable 100 V bus that result in a DEFLECTION ERROR readout.

Assume that the Latch Pulse for the counter has just occurred. The nominal calibrated level (0.0%) on pin 3 of U460 is 9 V. A decrease in voltage on the 100 V bus pulls pin 3 of U470 negative below zero and C462 begins to charge through R460, producing the first ramp after the Latch Pulse. During this charge time, the output of U470 is high and the counter is counting up to a count of 200 (00). Q475 is turned on and light-coupled through U480 to the base of Q480. The collector of Q480 is high, turning on CR480 and HIGH indicator light DS480.

The system contains two reference current sources; a +I_r source from the collector of Q415 and a -I_r source from the collector of Q400. Only one of these current sources is switched on at a given time, dependent on the polarity of the voltage change on the 100 V bus. For a ramp that is negative, pin 5 of U400B is set high and pin 1 of U400A is set to a low. Pins 2 and 4 of these NAND gates connect to a common control line and, while the counter is counting up to a count of 200 (00), pin 8 of U400C is at a low level. During the first ramp period, the output levels of U400A and U400B are high and both reference current sources are cut off. See Fig. 3-1.

When the counter has reached a count of 200 (00), a negative-going Full Pulse appears on pin 9 of U400C. This Full Pulse switches the common control line (pin 8) to a high level. Pin 3 of U400A remains high while pin 6 of U400B goes low, turning off Q410. Q415 is switched on for the +I_r discharge current to C462. The ramp on pin 3 of U470 switches polarity (runs toward zero). The counter begins to accumulate the necessary counts for display. Q435 has been turned on by the Full Pulse and light-coupled through U535 to the emitter of Q540, cutting this transistor off.

When the ramp crosses the 0 V level, a negative-going Latch Pulse occurring on pin 7 of U470 is transmitted through C506 and CR502 to pin 13 of U400D. This Latch Pulse switches pin 8 (common control line) of U400C to a low, locking out both reference current sources and turning off Q535. A positive-going Latch Pulse appears at the collector of Q565 to store the count in the counters for display. After the Latch Pulse has been produced at zero crossing, C462 again starts to charge through R460 (ramp increases in a negative direction) and the cycle repeats.

For input voltages above 100 V, the circuit action is similar to the action just discussed; except that the dual ramps on pin 3 of U470 are positive, DS482 is turned on for a LOW indication of DEFLECTION ERROR, and the -I_r

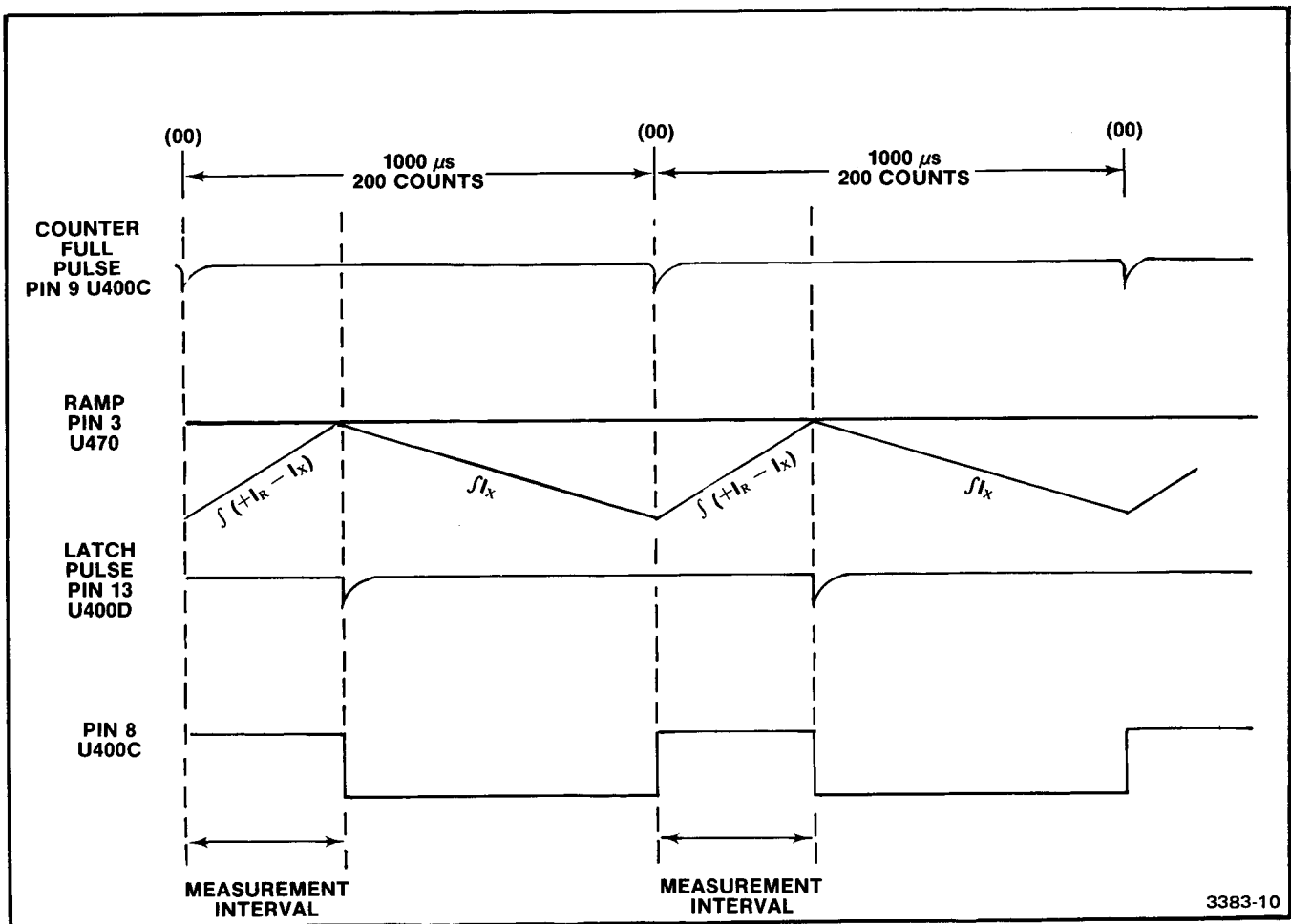

Fig. 3-1. DVM timing diagram for a negative input to the integrator U460.

reference current source is used to discharge C462. For positive ramps, the Latch Pulse occurring at zero crossing is transmitted through C500 and CR500 to pin 13 of U400D.

Reference currents from both reference sources track with changes on the 100 V bus and in the same direction, allowing the instrument to be calibrated directly for oscilloscope deflection error rather than output amplitude from the PG 506. The adjustment of R415 calibrates the HIGH indication, while the adjustment or R425 calibrates the LOW indication.

CR395 and CR397 protect components in the DVM circuitry if the + and -16.5 V input connections are accidentally reversed.

Period Generator and Display 4

The Period Generator circuit consists of six transistors (Q575, Q580, Q585, Q595, Q605, and Q610) and timing

capacitor C580 in series with main timing resistors R587, R590, and R593. These components set a basic 0.5 μs period (2 MHz square-wave signal) for the entire instrument.

The timing capacitor and resistor(s) have a common connection at the base of Q580. The signal on the base of Q580 is basically a linear ramp (with switching transients) that causes the output level at the collector of Q605 to go high and low when the ramp crosses the hysteresis limits of the circuit.

Assume that when power is applied, Q575 turns on and Q580 turns off. This action also turns off Q595, setting one end of the timing resistors to the saturated level at the collector of Q595. The base of Q580 now begins a ramp rundown toward the lower limit of the hysteresis window. C580 is charging toward a 5 V supply through R582 and the timing resistors. When the ramp at the base of Q580 crosses the lower limit of the hysteresis window, Q580 turns on and Q575 turns off. This action turns Q585 on and

Q595 off. R593 is now disconnected from essentially a ground potential and connected to a 5 V supply through Q610. The effective voltage across the timing resistors has now changed polarity and C580 begins to discharge because the emitter of Q585 is essentially at zero. The base of Q580 begins a ramp runup toward the upper limit of the hysteresis window. When the ramp crosses the upper limit, Q580 is again turned off and Q575 turned on, reconnecting the timing resistors to the collector level of Q595. The voltage swing across R600 (caused by Q580 turning on and off) are inverted by Q605 and applied as TTL levels to pin 14 of U665.

U665, U666, U667, and U668 operate as a divide-by-ten frequency dividers (multiplies input period by ten) with a 0.2 kHz (5 ms) square-wave on pin 11 of U668 and a 5 μ s (200 kHz) square-wave on pin 11 of U665. Input data for the counter latch circuits originates on pins 1, 12, 9, 8, and 11 of U666 and U667, respectively. BCD data from the counter latches (U670-U671) is decoded by U673 and U675 to drive the seven-segment LED displays (DS700-DS702).

U610A and U610B are each one-half of a dual J-K master-slave flip-flop. The input to pin 1 of U610A is always a 2 kHz signal, obtained from pin 11 of U667. Pin 12 of U610 is a Q terminal and the 1 kHz output signal is used to drive the diode section of U255 in the Standard Amplitude circuitry. To remove the 1 kHz drive to the Standard Amplitude circuitry when it is not needed, pin 2 of U610A is held low, which sets pin 12 to a logical zero. The Standard Amplitude circuitry is in a dc mode when pin 2 is grounded by the closure of S660. For the High Amplitude mode, pin 2 is grounded through CR661; for the Fast Rise mode, through CR660. CR656 and CR657 provide ground connections for the PERIOD light when the PG 506 is used as a Pulse Generator.

The input signals to U610B (as selected by the PERIOD control) are obtained from the frequency dividers (pin 11) or directly from the 2 MHz Period Generator. The period of the output signals on pins 8 and 9 of U610B are twice the selected input period. These signals are applied to NAND gates U615B and U615C to drive the High Amplitude or Fast Rise circuits. The drive signals on one input terminal of a NAND logic device are gated through with inverted polarity if the other input terminal is held high. The +TRIG OUT signals are supplied by inverter connections of U615A and U615D. To remove (lockout) drive signals through both NAND gates when they are not needed (Standard Amplitude mode), pin 6 of U610B is held low by the closure of S180A-5B. This action sets pin 9 of U610B to a logical zero (low) and pin 8 to a logical one (high).

The closure of S180A-7B locks out drive signals to the High Amplitude circuitry when the instrument is in a Fast

Rise mode; for the High Amplitude mode, the closure of S180A-6B locks out signals to the Fast Rise circuitry.

To disable the High Amplitude power supply when operating in a Standard Amplitude mode, CR616 is grounded through S180A-5B. When operating in a Fast Rise mode, CR615 is grounded through S180A-7B.

High Amplitude



The negative-going output, with Q745 and Q758 supplying the current, is developed across resistor R805 and the external load. CR755 and CR756 operate as disconnect diodes at the 0 V output levels. The specified reference is the positive-going edge of the output waveform, requiring that Q745 be switched off for the output to swing from a negative potential to ground. Q760 serves as a 2 mA current shunt through disconnect diodes CR766 and CR767. This circuit absorbs the leakage currents from Q745 and Q758 during transitions and adds a slight amount of reverse bias to the output disconnect diodes, improving the risetime and ensuring very sharp corners for the output voltage swing.

The transistors Q745 and Q758 are connected in cascode and the voltage transitions at the base of Q745 determines the output current swing. A negative transition at the base of Q745 requires a negative-going transition at the base of Q715 to saturate Q730 and cut off the output current.

The High Amplitude circuitry is floating on a variable power supply with limits of about -10 V to a maximum of about -72 V. The collectors of Q725, Q740, and Q790 translate the dc (and signal) levels from ground to a negative supply for the output stages and amplitude control circuitry. Q790 is a 4 mA current source that floats the amplitude control circuitry at about 6 V more positive than the variable supply voltage level.

R736 in the emitter of Q736, along with R746 in the emitter of Q745, are chosen so that the current into these nodes is a function of the actual supply voltage. The actual current that enters Q745 is controlled by the base voltage and the voltage drop across R745. The emitter of Q736 is a low-impedance driving point that controls the output current limits. Q736 also temperature-compensates the base junction of Q745. The base of Q736 (and the collector of Q782) is considered to be a zero temperature coefficient voltage point.

The PULSE AMPLITUDE control is R785A, located in the base circuit of Q784. This control obtains its reference voltage from across VR790. Q780 and Q784 form a differential circuit with Q780 connected as a diode for

Theory of Operation—PG 506 (SN B040000 & up)

temperature compensation. Q736 is driven by Q782, which adds additional gain to set the base of Q780 equal to the base of Q784. R784 sets the minimum output current limit and R790 is adjusted to set a 5.2 V output amplitude across a 50 Ω load. CR734, connected between the variable supply and the most negative level of the amplitude control circuitry, allows an additional 0.7 V voltage drop across Q780 and Q782, thereby improving the amplitude linearity.

The sensing point to regulate any one level of the variable supply is at the collector of Q790. A drift in the supply voltage is level shifted through VR790 and applied to pin 2 of U840. CR27 is turned on to control the level at pin 4 of U20, the voltage regulator in the Primary Power supply.

The actual voltage of the variable supply is made a function of the negative peak levels of the output signal. The negative peaks are sampled through CR800 and emitter-follower Q800 to store a charge on memory capacitor C800. If the output signal amplitude is increase (larger negative peaks), pin 3 of U840 goes negative. A negative charge on pin 4 of U840 results in a larger dc supply for the inverter system in the Primary Power circuit and the variable supply to the High Amplitude circuit goes more negative. The net result is that the voltage drop across the output transistors remains relative constant. The variable supply tracks with the selected output amplitude and in the same direction. The emitter of Q745 is connected through VR790 to pin 2 of U840; the drain of Q758 is connected through Q800 to U840 pin 3. Because an operational amplifier (U840) always attempts to reduce the voltage difference between its input terminals to zero, the constant voltage drop across the output transistor network is essentially equal to the drop across VR790 plus about 2 to 7 V across other components in the feedback loop.

Fast Rise

6

The Fast Rise circuit produces two output signals that occur simultaneously. Q935 and Q995 operate as non-saturated current-mode switching sources for the output signals. CR944 and CR1004 are disconnect diodes that have very low leakage current characteristics at zero-bias levels. These levels occur when Q935 and Q995 are cut off.

In order to produce 1 V across a 25 Ω load (50 Ω termination in parallel with either R950 or R1010) it requires 40 mA. This current is available through resistors

in series with the emitters of Q935 and Q995. A negative transition occurs at J950 when Q935 is turned off and a positive transition occurs at J1010 when Q995 is turned off. Both transistors turn off simultaneously with R935 and R995 providing return paths for leakage currents. C940 and C1000 are provided to reduce excessive overshoot and ringing. R940 and R1000 are selected for minimum aberrations and maximum risetime with an optimum value of 120 Ω .

Simultaneous amplitude control of the output signals is accomplished by diverting current from the emitters of Q935 and Q995 through the series path of Q1036 and Q1045. The voltage drop across R1040 is controlled by the adjustable voltage level at the emitter of Q1030, a low impedance source for the base of Q1036. Q1020 operates as a current switch to set the collector of Q1030 to about 5 V when the Fast Rise mode is selected. R1025 sets the minimum amplitude available at the output and R785B controls the minimum and maximum amplitudes.

When the Fast Rise mode is switched off, the + and -16.5 V supplies are switched off. The collectors of Q1020 and Q1030 drop to about zero, driving the base of Q1036 negative. This action completely cuts off the leakage currents that might have existed in the collectors of Q935, Q1036, Q995, and Q1045 if the collector of Q1030 had been tied to a fixed 5 V source. This arrangement ensures that the output connectors rest at a 0 V level with the instrument is not in a Fast Rise mode.

Q860 and Q862 operate as a Schmitt trigger for the Fast Rise circuit, with VR866 providing positive feedback and Q850 serving as a constant-current source. A positive-going pulse at the base of Q860 results in a negative-going pulse at the collector of Q880 and a positive-going pulse at the collector of Q890, where the transitions are speeded up and translated to ground levels by R882 and R892. At this point, the signal currents are split into two paths through differential amplifiers (Q900-Q910 and Q960-Q970). For a positive-going input to the base of Q960, the emitter of Q935 is driven negative by the saturation of Q920 and the emitter of Q995 is driven positive by the saturation of Q980.

CR1062 and CR1067 protect the Fast Rise circuit components if the wiring plug to the circuit board is accidentally reversed. The diodes in the base circuits of Q1030 and Q1045 are for temperature compensation.

CALIBRATION PROCEDURE

PERFORMANCE CHECK PROCEDURE

Introduction

The performance check procedure checks the electrical performance requirements listed in the Specification section in this manual. Perform the Adjustment procedure if the instrument fails to meet these checks. If recalibration does not correct the discrepancy, troubleshooting is indicated. This procedure may be used to determine acceptability of performance in an incoming inspection facility.

For convenience, many steps in the procedure check the performance of this instrument at only one value in the specified performance range. Performance requirements for various temperature ranges are listed in this procedure. When performing the procedure, use only the limits listed for the ambient temperature that the instrument is operating in.

Calibration Interval

To ensure instrument accuracy, check the calibration every 2000 hours of operation or a minimum of every six months if used infrequently.

Services Available

Tektronix, Inc. provides complete instrument repair and adjustment at local field service centers and at the factory service center. Contact your local Tektronix field office or representative for further information.

Test Equipment Required

The following test equipment or equivalent is suggested to perform the Performance Check and Adjustment Procedure.

Table 4-1

TEST EQUIPMENT REQUIRED

Description	Performance Requirements	Applications	Example
Oscilloscope System	200 MHz vertical bandwidth 1 mV/div at 60 Hz; 5 mV/div to 5 V/div	Waveshape and amplitude measurements, Risetime	TEKTRONIX 7704A TEKTRONIX 7A16A ^a TEKTRONIX 7B80 ^a TEKTRONIX 7A11 ^a
Sampling System	Risetime—30 ps or less, 2 mV to 200 mV sensitivity; Time/Div 10 ps to 5 ms.	Risetime and aberration measurements	TEKTRONIX 7S11 ^a TEKTRONIX S-6 TEKTRONIX 7T11 ^a
Precision Volt/Ohmmeter	100 Vdc to 100 mV +0.025% accuracy; resistance from 50 Ω to 1 k Ω within \pm 0.05%	Dc voltage and resistance measurements	JOHN FLUKE Model 8375A
50 Ω Termination	0.1% accuracy, bnc connectors		Tektronix Part No. 011-0129-00
Power Module		All tests	Compartments for the PG 506 (1) and other TM 500-Series equipment used.

Table 4-1 (cont)

TEST EQUIPMENT REQUIRED

Description	Performance Requirements	Applications	Example
50 Ω Termination (2 required)	Bnc connectors		Tektronix Part No. 011-0049-01
50 Ω Termination	Sma connectors		Tektronix Part No. 015-1022-00
50 Ω Attenuator	10X, bnc connectors		Tektronix Part No. 011-0059-02
50 Ω Attenuator	10X, sma connectors		Tektronix Part No. 015-1003-00
Cable	18", 50 Ω , bnc connectors		Tektronix Part No. 012-0076-00
Cable	42", 50 Ω bnc connectors		Tektronix Part No. 012-0057-01
Cable, Precision (2 required)	36", 50 Ω , bnc connectors		Tektronix Part No. 012-0482-00
Adapter	Female to female, bnc connectors		Tektronix Part No. 103-0028-00
Adapter (2 required)	Male to male, sma connectors		Tektronix Part No. 015-1011-00
Adapter	Male sma to female bnc connector		Tektronix Part No. 015-1018-00
Tunnel Diode Pulser		Sampling system veri- fication	Tektronix Part No. 067-0645-02
Extender Cable	To match power module and PG 506 connectors		Tektronix Part No. 067-0645-02
20 mA Constant Current Source	See the Maintenance Section for details	Attenuator Accuracy	
Time-mark Generator	1 ns, within 0.1%	Sampling system veri- fication	TEKTRONIX TG 501 ^b

^a Requires a TEKTRONIX 7000-Series Mainframe.

^b Requires a TEKTRONIX TM 500-Series power module.

Preliminary Procedure

1. Ensure that all power switches are off.

2. Ensure that all test equipment and the power module into which the PG 506 under test will be installed are suitably adapted to the line voltage to be applied.

**PERFORMANCE CHECK
PROCEDURE**

1. Check High Amplitude Output Resistance: within 5%

- a. Connect the precision volt/ohmmeter to the AMPL OUTPUT HIGH or STD connector.

- b. Set the function switch to HIGH AMPL.

- c. CHECK—that the output resistance is 600, $\pm 30 \Omega$.

2. Check Std Ampl Output Resistance: within 0.5%

- a. Set the function switch to STD AMPL.

- b. Set the AMPLITUDE (VOLTS INTO 1 M Ω) to the counterclockwise position.

- c. CHECK—that the resistance is 50, $\pm 0.25 \Omega$.

3. Check Fast Rise Output Resistance: within 5%

- a. Connect the precision volt/ohmmeter to the FAST RISE OUTPUTS left hand connector.

- b. CHECK—that the output resistance is 50, $\pm 1.5 \Omega$.

- c. Connect the precision volt/ohmmeter to the FAST RISE OUTPUTS right hand connector.

- d. Repeat part b.

4. Check Standard Amplitude dc Voltages (into 1 M Ω)

- a. Remove the PG 506 side cover to gain access to the internal DC—Pulse switch. Pull the rear end of the side cover outward from the instrument side (the cover snaps into place).

- b. Set the internal DC—Pulse (S660) switch to DC (up).

- c. Replace the side cover on the PG 506 and install the PG 506 into the power module.

- d. Connect the power module(s) and test equipment to a suitable line voltage source. Turn all equipment on and allow at least 20 minutes for the equipment to warm up and stabilize.

- e. Set the precision volt/ohmmeter to measure 100 Vdc.

NOTE

A shunt of the voltmeter input terminals is required that ensures that the total load resistance on the AMPL OUTPUT connector is 1 M Ω within 0.1%; e.g., 1.11 Ω load resistor with a voltmeter that has a 10 M Ω input impedance.

- f. Connect the PG 506 AMPL OUTPUT HIGH or STD to the 1 M Ω voltmeter input.

- g. Set the PG 506 AMPLITUDE switch as listed in Table 4-2.

- h. CHECK—that the voltmeter reads within the given limits as listed in Table 4-2.

**Table 4-2
STANDARD AMPLITUDE (INTO 1 M Ω)
WITHIN 0.25%, $\pm 1 \mu\text{V}$**

AMPLITUDE Setting	Limits	
100	99.75 V	to 100.25 V
50	49.875 V	to 50.125 V
20	19.95 V	to 20.05 V
10	9.975 V	to 10.025 V
5	4.9875 V	to 5.0125 V
2	1.995 V	to 2.005 V
1	0.9975 V	to 1.0025 V
.5	0.49875 V	to 0.50125 V
.2	0.1995 V	to 0.2005 V
.1	0.09975 V	to 0.10025 V

**Calibration Procedure—PG 506 (SN B040000 & up)
Performance Check**

i. RECORD—the voltmeter reading for the .1 Amplitude setting.

j. Turn off the power module and remove the PG 506.

k. Connect the variable 20 mA current source positive lead to the top or R308. See Fig. 4-1.

l. Connect the variable 20 mA current source negative lead to the common floating ground. See Fig. 4-1.

m. Set the 20 mA variable current source output to obtain a voltmeter reading exactly ten times the 6-digit voltage recorded in part i.

n. Set the PG 506 AMPLITUDE control to 10 mV.

o. CHECK—that the voltmeter reading is 0.10025 to 0.09975 V.

p. RECORD—the actual voltmeter reading for the 10 mV range.

q. Connect the variable 20 mA current source positive lead to the top of R304. See Fig. 4-1.

r. Set the current source output to obtain a voltmeter reading exactly ten times the 6-digit voltage recorded in part p.

s. Set the PG 506 AMPLITUDE control to 1 mV.

t. CHECK—that the voltmeter reading is 0.10025 to 0.09975 V.

u. Disconnect the 20 mA variable current source and plug the PG 506 into the power module.

v. Turn on the power module and allow 20 minutes warm-up before continuing.

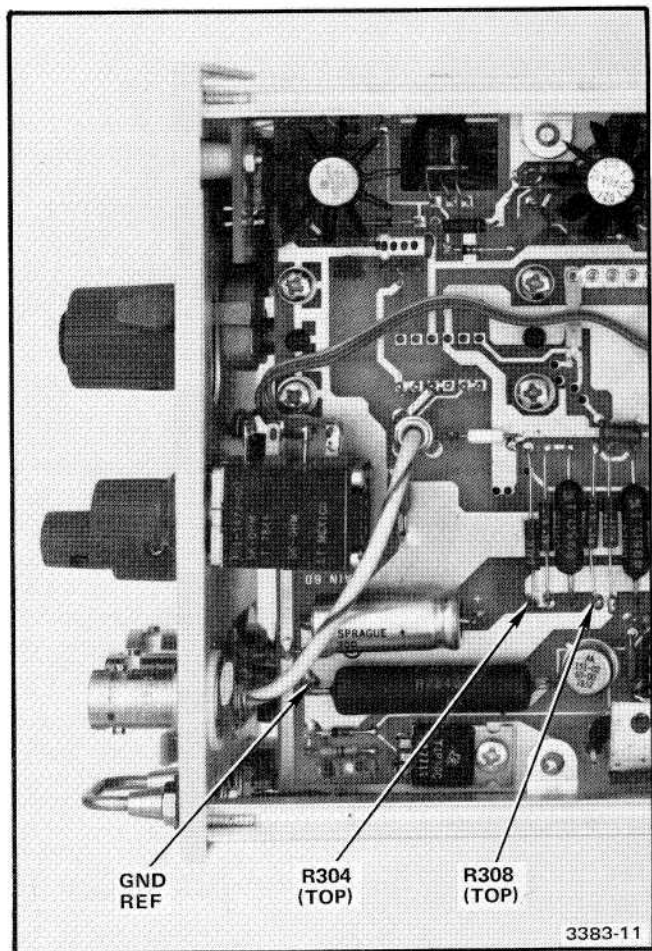

Fig. 4-1. Attenuator connections for current source.

5. Check DEFLECTION ERROR Range; + & -7.5%, resolution within 0.1%

a. Set the precision volt/ohmmeter to measure 100 Vdc.

b. Set the AMPLITUDE control to 100.

c. Press and release the VARIABLE (OUT) control.

d. Set the VARIABLE (OUT) control for a reading on the precision volt/ohmmeter as listed in Table 4-3.

e. CHECK—that the DEFLECTION ERROR % readout display is within the display tolerance listed in Table 4-3.

Table 4-3

100 V dc RANGE DEFLECTION ERROR %
RESOLUTION TOLERANCES

Voltmeter Reading	Display Tolerance
108.5 V	7.7% to 7.9% LOW lamp lit
107.3 V	6.6% to 7.0% LOW lamp lit
106.5 V	5.9% to 6.3% LOW lamp lit
105.6 V	5.1% to 5.5% LOW lamp lit
104.6 V	4.2% to 4.6% LOW lamp lit
103.2 V	2.9% to 3.3% LOW lamp lit
100.0 V	0.0% to 0.2% LOW or HIGH lamp lit
96.9 V	3.0% to 3.4% HIGH lamp lit
95.6 V	4.4% to 4.8% HIGH lamp lit
94.7 V	5.4% to 5.8% HIGH lamp lit
93.9 V	6.3% to 6.7% HIGH lamp lit
93.2 V	7.1% to 7.5% HIGH lamp lit
92.8 V	7.7% to 7.9% HIGH lamp lit

f. Set the AMPLITUDE control to 10.

g. CHECK—that the DEFLECTION ERROR % readout display is within 0.1% as listed in Table 4-4.

Table 4-4

10 V dc RANGE DEFLECTION ERROR %
RESOLUTION TOLERANCES

Voltmeter Reading	Display Tolerance
10.81 V	7.3% to 7.7% LOW lamp lit
10.56 V	5.1% to 5.5% LOW lamp lit
10.00 V	0.0% to 0.2% HIGH or LOW lamp lit
9.47 V	5.4% to 5.8% HIGH lamp lit
9.30 V	7.3% to 7.7% HIGH lamp lit

h. Press in and turn-off the VARIABLE (OUT) control.

6. Check Standard Amplitude Voltages (into 50 Ω load)

a. Set the precision volt/ohmmeter to measure 5 V dc.

b. Connect the precision 50 Ω termination to the AMPL OUTPUT HIGH or STD connector.

c. Connect the precision coaxial cable from the termination to the precision volt/ohmmeter input.

NOTE

The Standard Amplitude output voltage accuracy (operating into a 50 Ω load) is highly dependent on the total load resistance. The total load consists of the coaxial cable resistance, all contact resistance, and the termination accuracy. Total load resistance error must not exceed 0.1%.

d. CHECK—that the voltage readings for the AMPLITUDE settings are within the limits listed in Table 4-5.

Table 4-5
STANDARD AMPLITUDE INTO A
50 Ω LOAD

AMPLITUDE Setting	Voltage Reading	Limits
10	5 V	4.9875 V to 5.0125 V
5	2.5 V	2.49375 V to 2.50625 V
2	1 V	0.9975 V to 1.0025 V
1	0.5 V	0.498749 V to 0.50125 V
.5	0.25 V	0.249374 V to 0.250626 V
.2	0.1 V	0.099749 V to 0.100251 V

e. Remove all connections.

f. Turn off the power module and remove the PG 506.

g. Remove the PG 506 side cover to gain access to the internal DC—Pulse switch (S660). Pull the rear end of the side cover outward from the instrument side (the cover snaps into place).

h. Set the DC—Pulse switch (S660) to Pulse (down).

**Calibration Procedure—PG 506 (SN B040000 & up)
Performance Check**

- i. Replace the side cover and install the PG 506 into the power module.
- j. Turn on the power module power.
- k. Allow for a 20 minute stabilization period.

7. Check Standard Amplitude Period Accuracy

Set the following controls as indicated:

PG 506	
AMPLITUDE	20
VARIABLE (OUT)	in
Function	STD AMPL

Monitor Oscilloscope

Volts/Div	5 V
Time/Div	.2 ms

- a. Using a 50 Ω coaxial cable, connect the PG 506 AMPL OUTPUT HIGH or STD to the vertical input of the monitor oscilloscope.
- b. Set the monitor oscilloscope triggering controls for a stable display.
- c. CHECK—for one complete cycle in 5 divisions, ±0.25 divisions.
- d. Disconnect the PG 506 from the monitor oscilloscope.

8. Check Standard Amplitude Output (into 50 Ω)

Set the following controls as indicated:

PG 506	
AMPLITUDE	10
VARIABLE (OUT)	in

Monitor Oscilloscope

Volts/DIV	1 V
-----------	-----

- a. Using the 50 Ω coaxial cable and 50 Ω termination, connect the PG 506 AMPL OUTPUT HIGH or STD to the vertical input of the monitor oscilloscope.

- b. Set the monitor oscilloscope triggering controls for a stable display.
- c. CHECK—for approximately 5 V peak-to-peak of output signal.

9. Check High Amplitude Output (into 50 Ω)

Set the following controls as indicated:

PG 506

Function	HIGH AMPL
PERIOD	1 μs 1 MHz
VAR	ccw
PULSE AMPLITUDE	cw

Monitor Oscilloscope

Volts/Div	1 V
Time/Div	.5 μs

- a. Using the 50 Ω coaxial cable and 50 Ω termination, connect the PG 506 AMPL OUTPUT HIGH or STD to the vertical input of the monitor oscilloscope.
- b. CHECK—that the display amplitude is ≥5 V.

10. Check Trigger Out Amplitude

- a. Using the 50 Ω coaxial cable and 50 Ω termination, connect the +TRIG OUT to the vertical input of the monitor oscilloscope.
- b. Change the Volts/Div to .5 V.
- c. CHECK—that the display amplitude is ≥1 V.
- d. Remove all connections.

11. Check High Amplitude Output (open ckt)

Set the following controls as indicated:

PG 506

Function	HIGH AMPL
PULSE AMPLITUDE	MAX
PERIOD	1 μs 1 MHz

Monitor Oscilloscope

Volts/Div	2 V
-----------	-----

**Calibration Procedure—PG 506 (SN B040000 & up)
Performance Check**

- a. Using a 10X probe connected to the vertical input, connect the tip to the AMPL OUTPUT HIGH or STD.
- b. Use a probe ground lead and ground the probe.
- c. CHECK—that the high amplitude is ≥ 60 V.
- d. Rotate the PULSE AMPLITUDE counterclockwise.
- e. Change the monitor oscilloscope Volts/Div to 50 mV (deflection factor with probe of 0.5 V/div).
- f. CHECK—that the High Amplitude output is ≤ 6 V.
- g. Remove the probe.

12. Check High Amplitude Output Period

Set the following controls as indicated:

PG 506

Function	HIGH AMPL
PULSE AMPLITUDE	midrange
PERIOD	1 μ s 1 MHz
VAR	ccw

Monitor Oscilloscope

Volts/Div	1 V
Time/Div	.2 μ s

- a. Using a 50 Ω coaxial cable and 50 Ω termination, connect the AMPL OUTPUT HIGH or STD output to the vertical input of the monitor oscilloscope.

- b. Set the monitor oscilloscope triggering controls for a stable display.

- c. CHECK—that the High Amplitude output period display for one full cycle is within the limits listed in Table 4-6.

13. Check Fast Rise Output Period

Set the following controls as indicated:

PG 506

Function	FAST RISE
PULSE AMPLITUDE	mid range
PERIOD	1 μ s 1 MHz
VAR	ccw

Monitor Oscilloscope

Volts/Div	.1 V
Time/Div	.2 μ s

- a. Using a 50 Ω coaxial cable and 50 Ω termination, connect the positive-going FAST RISE OUTPUTS to the vertical input of the monitor oscilloscope.

- b. Set the monitor oscilloscope triggering controls for a stable display.

- c. CHECK—that the fast rise output period display for one cycle is within the limits listed in Table 4-6.

- d. Change the PG 506 connection to the negative-going FAST RISE OUTPUTS connector and repeat parts b and c.

**Table 4-6
FAST RISE AND HIGH AMPLITUDE OUTPUT PERIOD**

PG 506 Controls		Monitor Oscilloscope	
PERIOD Setting	VAR	Time/Div	Display Limits
1 μ s 1 MHz	ccw	.2 μ s	4.75 to 5.25 divisions
10 μ s 100 kHz	ccw	2 μ s	4.75 to 5.25 divisions
.1 ms 10 kHz	ccw	20 μ s	4.75 to 5.25 divisions
1 ms 1 kHz	ccw	.2 ms	4.75 to 5.25 divisions
10 ms 100 Hz	ccw	2 ms	4.75 to 5.25 divisions
10 ms 100 Hz	cw	20 ms	>5 divisions

**Calibration Procedure—PG 506 (SN B040000 & up)
Performance Check**

14. Check Fast Rise Output Amplitude

Set the following controls as indicated:

PG 506

Function	FAST RISE
PULSE AMPLITUDE	MAX
PERIOD	1 μ s 1 MHz
VAR	ccw

Monitor Oscilloscope

Volts/Div	.2 V
Time/Div	1 μ s

- a. Center the display on the monitor oscilloscope.
- b. CHECK—that the display amplitude is ≥ 5 divisions.
- c. Change the PG 506 connection to the positive-going FAST RISE OUTPUTS.
- d. Repeat part b.
- e. Set PULSE AMPLITUDE to MIN and the monitor oscilloscope Volts/Div to 20 mV.
- f. CHECK—that the display amplitude is ≤ 5 divisions.
- g. Change the PG 506 connection to the negative-going FAST RISE OUTPUTS.
- h. Repeat part f.

NOTE

The following step is used for determining the timing accuracy and response to a voltage step of the sampling system. The procedure need not be accomplished if the sampling system timing accuracy and step response are known.

15. Sampling System Timing Accuracy and Step Response

Set the following controls as indicated:

Sampling System

7S11

mV/Div	100
Variable	in
+Up	in
Delay (10 ns range)	midrange
Dot Response	midrange
Normal (pushbutton)	in
Dc Offset	midrange

7T11

Slope	+
Sequential	in
Scan	midrange
Rep (pushbutton)	in
Time Pos Rng	50 ns
Time/Div	1 ns
Trig Input	Ext 50 Ω 2 V max

TG 501

Marker (Sec)	5-2-in
Variable	in
1 ns (pushbutton)	in

- a. Install the S-6 Sampling Head in the 7S11.
- b. Make the following connections as indicated:
 - Sma male to bnc female adapter to the S-6 sampling head upper connector.
 - TG 501 1 ns Only output through a 50 Ω coaxial cable and 50 Ω termination to the S-6 upper connector.
 - Sma 50 Ω terminator to the S-6 sampling head lower connector.
 - Sma male to bnc female adapter to 7T11 Trig Input.
 - TG 501 +Trigger Out through a 50 Ω coaxial cable to the 7T11 Trigger input.
- c. Using the 7S11 Dc Offset, center the display.
- d. Using the 7T11 Time Position, place the 50% point of the positive-going sinewave on the second horizontal graticule line.
- e. CHECK—that the ninth positive-going sinewave 50% point crosses the tenth horizontal graticule line.

f. Adjust—7T11 Sweep Cal only if necessary to ensure the 50% point crosses the tenth horizontal graticule line.

g. Remove the TG 501 connections to the sampling system.

h. Using a 50 Ω coaxial cable, connect the PG 506 AMPL OUTPUT HIGH or STD to the TD Pulser input.

i. Connect the TD Pulser to the upper S-6 input connector.

j. Using the necessary adapters and a 10X attenuator, connect the lower S-6 connector (loop thru) output to the 7T11 Trig Input.

k. Using the 7T11 triggering controls, obtain a stable display.

l. Set the 7T11 Time Pos Rng to .5 μ s and Time/Div to 1 ns.

m. Adjust the TD Pulser triggered level slowly clockwise to the point where the tunnel diode fires.

n. Using the 7T11 triggering controls and time position, locate the leading pulse edge.

o. Using the 7S11 Variable and DC Offset, obtain a peak-to-peak display of 5 divisions.

p. Using the 7T11 Time Position control, set the leading edge of the pulse at the second horizontal graticule division.

NOTE

Each vertical division now represents 2% of the total pulse amplitude.

q. Using the 7S11 Dc Offset, center the step top in the display area. Refer to Fig. 4-2.

r. Using the 7T11 Scan control, adjust for a scan rate with minimum display flicker.

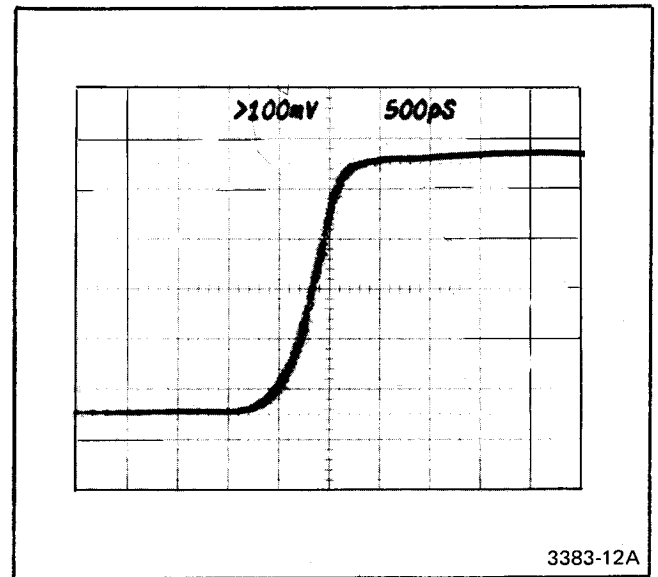

Fig. 4-2. Typical response curve of sampling system.

s. The sampling system aberrations can now be determined, and noted (for use in checking risetime and aberrations). Refer to Fig. 4-2.

16. Check Fast Rise Output Aberrations and Risetime

Set the following controls as indicated:

	PG 506	
Function	FAST RISE	
PERIOD	1 μ S	1 MHz
VAR	ccw	
	7T11	
Time Pos Rng	0.5 μ s	
Time/Div	50 ns	
	7S11	
mV/div	100 mV	
Variable	in	

a. Using the 7T11 triggering controls, obtain a stable display.

b. Using the PG 506 PULSE AMPLITUDE control, obtain a 5 division peak-to-peak display.

c. Set the 7T11 Time/Div to 1 ns.

**Calibration Procedure—PG 506 (SN B040000 & up)
Performance Check**

d. Using the 7T11 Time Position control, maintain the display on screen.

e. Set the 7S11 mV/Div to 10 mV.

f. Using the 7S11 Dc Offset control, position the top of the pulse in the display area.

g. CHECK—that the aberrations are within 2% (1 div). Refer to Fig. 4-3.

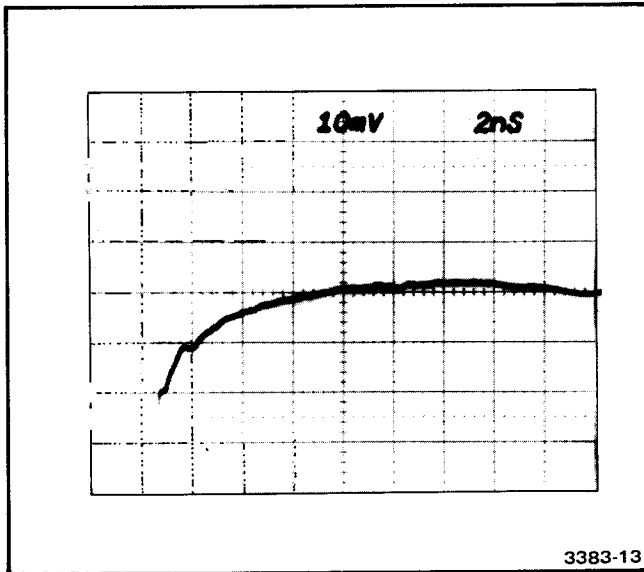

Fig. 4-3. Typical sampling oscilloscope response display.

h. Disconnect the coaxial cable from the positive-going FAST RISE OUTPUTS connector and connect it to the negative-going FAST RISE OUTPUTS connector.

i. Set the 7S11 mV/Div to 100 mV and the +Up/Invert switch to Invert.

j. Repeat parts a through f of this step.

k. CHECK—that the aberrations are within 2% (1 div). Refer to Fig. 4-4.

l. Set the following controls as indicated:

7S11 mV/div	100 mV
7T11 Time/Div	0.5 ns

m. Using the PG 506 PULSE AMPLITUDE control, obtain 5 divisions display amplitude.

n. Position the display to measure the risetime. Refer to Fig. 4-2.

o. CHECK—that risetime between the 10% and 90% point on the waveform is ≤ 1 ns.

p. Disconnect the coaxial cable from the negative-going FAST RISE OUTPUTS connector and connect it to the positive-going FAST RISE OUTPUTS connector.

q. Set the 7S11 +Up/Invert switch to +Up.

r. Using the PG 506 PULSE AMPLITUDE control, obtain 5 divisions display amplitude.

s. Position the display to measure the waveform risetime. Refer to Fig. 4-4.

t. CHECK—that the risetime between the 10% and 90% point is ≤ 1 ns.

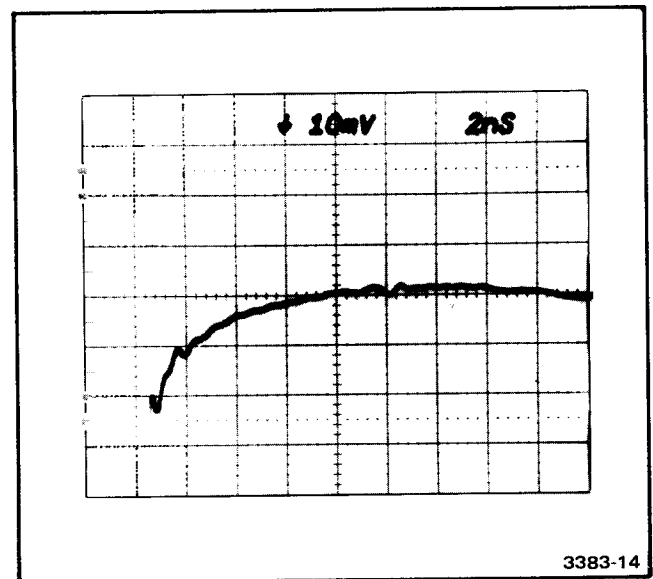

Fig. 4-4. Typical sampling oscilloscope response display.

17. Check Fast Rise Output Flatness

a. Set the 7T11 Time Pos Rng to 5 s and Time/Div to 50 ns.

**Calibration Procedure—PG 506 (SN B040000 & up)
Performance Check**

b. Using the 7T11 Time Position, set the rising edge of the display waveform on the first vertical graticule line.

c. CHECK—that the display waveform (following the first 10 ns or 0.2 div) flatness is within 0.25 divisions.

d. Disconnect the coaxial cable from the positive-going FAST RISE OUTPUTS connector and connect it to the negative-going FAST RISE OUTPUTS connector.

e. Set the 7S11 +Up/Invert to Invert.

f. Repeat parts b and c for the negative-going Fast Rise output.

d. Using the 7T11 Time Position and 7S11 dc Offset, place the 50% point of the positive-going waveform at the first vertical graticule line.

e. Set the 7S11 mV/Div to 10.

f. Using the 7S11 dc Offset, align the waveform with the vertical graticule.

g. CHECK—that the aberrations are $\leq 2\%$ in the first 50 ns.

h. Set the 7S11 mV/Div to 100 and the 7T11 Time/Div to 5 ns.

i. Using the 7S11 dc Offset and 7T11 Time Position, center the display.

j. CHECK—that risetime between the 10% and 90% point is ≤ 10 ns.

k. Remove the sampling system connections and plug-ins from the 7000-Series oscilloscope and install the real-time oscilloscope plug-ins.

l. Using an FET probe, connect the test oscilloscope vertical input directly to the AMPL OUTPUT HIGH or STD connector.

m. Set the following controls as indicated:

18. Check High Amplitude Output Risetime and Aberrations

Set the following controls as indicated:

PG 506

Function	HIGH AMPL
PERIOD	1 μ s 1 MHz
VAR	ccw
PULSE AMPLITUDE	MAX

7S11

mV/Div	100
+Up/Invert	+Up
Dot Response	midrange
Normal	in
Sequential	in

7T11

Time Pos Rng	5 μ s
Time/Div	.1 μ s
Sequential	in
Slop —	in
Trig Input	Ext 50 Ω 2 V Max
Trig Amp	X1

Test Oscilloscope

Volts/Div	20
Time/Div	50 ns

a. Using a 50 Ω precision coaxial cable, 10X attenuator, and sma to bnc female adapter, connect the AMPL OUTPUT HIGH or STD connector to the S-6 upper connector.

b. Using the 7S11 Variable and dc Offset controls, obtain a 5 division peak-to-peak amplitude display.

c. Set the 7T11 Time/Div to 50 ns.

n. Using the test oscilloscope triggering controls, obtain a stable display.

o. Using the vertical variable sensitivity and horizontal controls, place a 5 division positive-going waveform at midscreen.

p. CHECK—that risetime between the 10% and 90% point is ≤ 100 ns.

This completes the Performance Check.

ADJUSTMENT PROCEDURE

Introduction

This adjustment procedure is to be used to restore the PG 506 to original performance specifications. Adjustment need not be performed unless the instrument fails to meet the Performance Requirements of the Electrical Characteristics listed in the Specification section, or the Performance Check cannot be completed satisfactorily.

Completion of all adjustment steps in this procedure ensures that the instrument will meet the performance requirements listed in the Specification section. However, to fully ensure satisfactory performance, it is recommended that the Performance Check be performed after any adjustment is made.

Adjustment Instructions

The alphabetical instructions under each step (a, b, c, etc.) may contain Check, Examine, or Adjust as the first word of the instruction. These terms are defined as follows:

1. Check—indicates that the instruction accomplishes a performance requirement check. Each performance requirement is derived from the instrument specification as listed in the Electrical Characteristics in Section 1.

2. Examine—usually precedes an Adjust instruction and describes how to determine whether the adjustment is necessary. Measurement limits following the word Examine are not to be interpreted at performance limits derived from the instrument specifications. They are provided as indicators of a properly functioning instrument and to aid in the adjustment process.

3. Adjust—describes which adjustment to use to make the desired result. We recommend that adjustments not be made if a previous Check or Examine instruction indicates that no adjustment is necessary.

Adjustment Interval

To maintain instrument accuracy, check the performance of the Calibration Generator every 500 hours of operation, or every three months if used infrequently.

Services Available

Tektronix, Inc. provides complete instrument repair and adjustment at local Field Service Centers and at the Factory Service Center. Contact your local Tektronix Field Office or representative for further information.

Preparation

a. Remove the side covers of the PG 506 to gain access to the adjustments. Pull the rear end of the side cover outward from the side of the instrument (the cover snaps into place).

b. Be sure that the power module power switch is off. Set the power module for the line voltage to be applied and connect it to the line voltage source.

c. Install the other TM 500-Series equipment into the power module.

d. Connect the extender cable to the power module and connect the PG 506 to the extender cable.

e. Turn on all test equipment and allow 30 minutes for warm up and stabilization.

1. Adjust Primary Power Voltage

Set the following controls as indicated:

PG 506

Function	FAST RISE
AMPLITUDE	100
VARIABLE (OUT)	in
PULSE AMPLITUDE	MIN
PERIOD	1 μ s 1 MHz
VAR	ccw

a. Connect the voltmeter high input lead to the +16.5 V test point. Refer to Fig. 4-5.

b. Connect the voltmeter low input lead to the -16.5 V test point.

c. Examine—that the voltmeter indicates +32.8 Vdc to +33.2 Vdc.

d. Adjust—Primary Pwr, R30 for 33.0 Vdc.

e. Disconnect the leads.

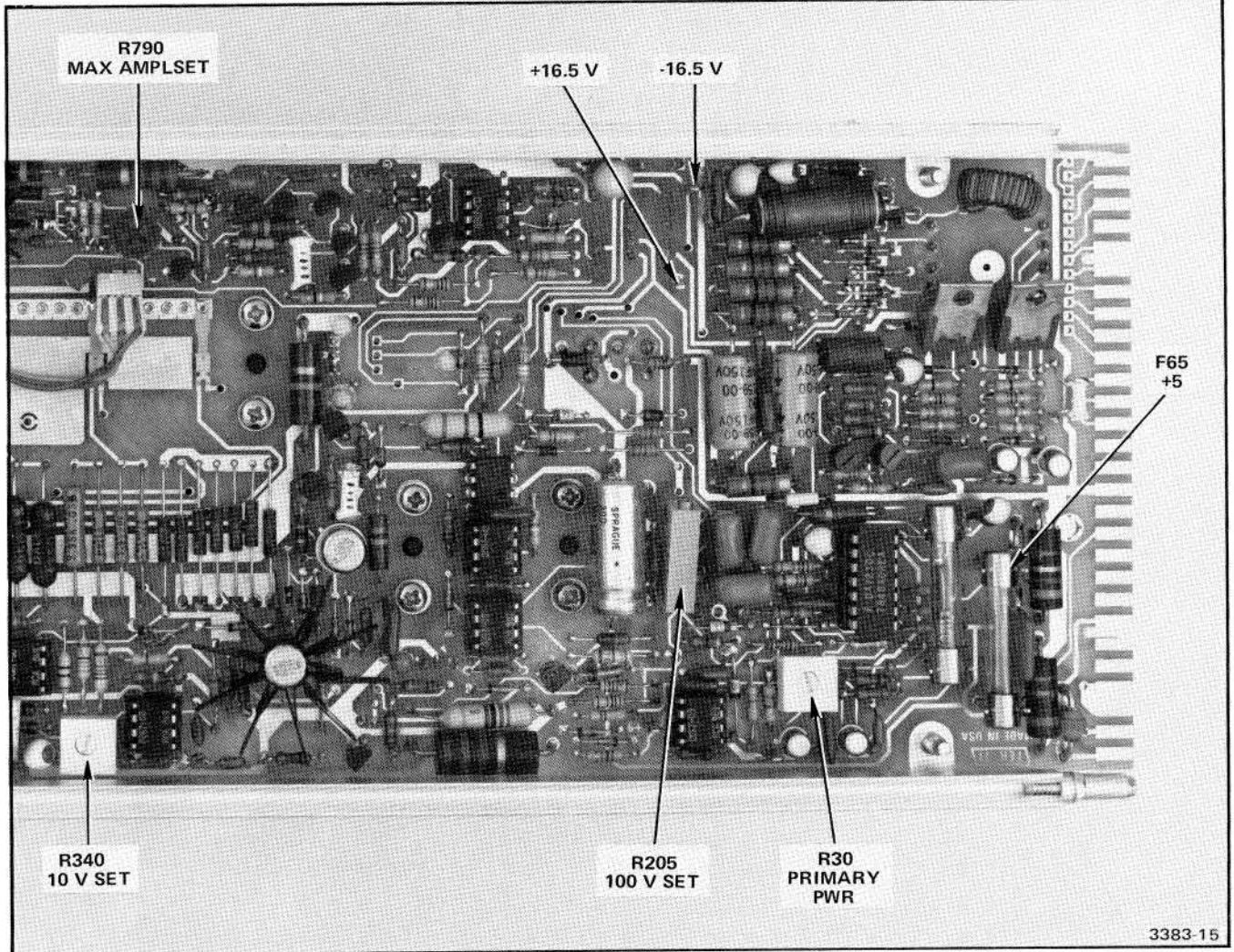

Fig. 4-5. Adjustment locations for the A1 Main circuit board.

2. Check +5 V Power Supply

- a. Connect the voltmeter low input lead to a convenient ground.
- b. Connect the voltmeter high input lead to the top end of F65. Refer to Fig. 4-5.
- c. Check—that the +5 V supply voltage is +4.75 Vdc to +5.25 Vdc.
- d. Disconnect the leads.

3. Adjust 100 V and 10 V Set

Set the following controls as indicated:

PG 506

Function	STD AMPL
AMPLITUDE	100
VARIABLE (OUT)	in
DC— (S660)	DC (up) Refer to Fig. 4-6.

- a. Set the precision volt/ohmmeter to measure 100 Vdc.

NOTE

A shunt of the voltmeter input terminals is required that ensures that the total load resistance on the AMPL OUTPUT HIGH or STD connector is 1 MΩ within 0.1%, e.g., 1.11 MΩ load resistor with a voltmeter that has a 10 MΩ input impedance.

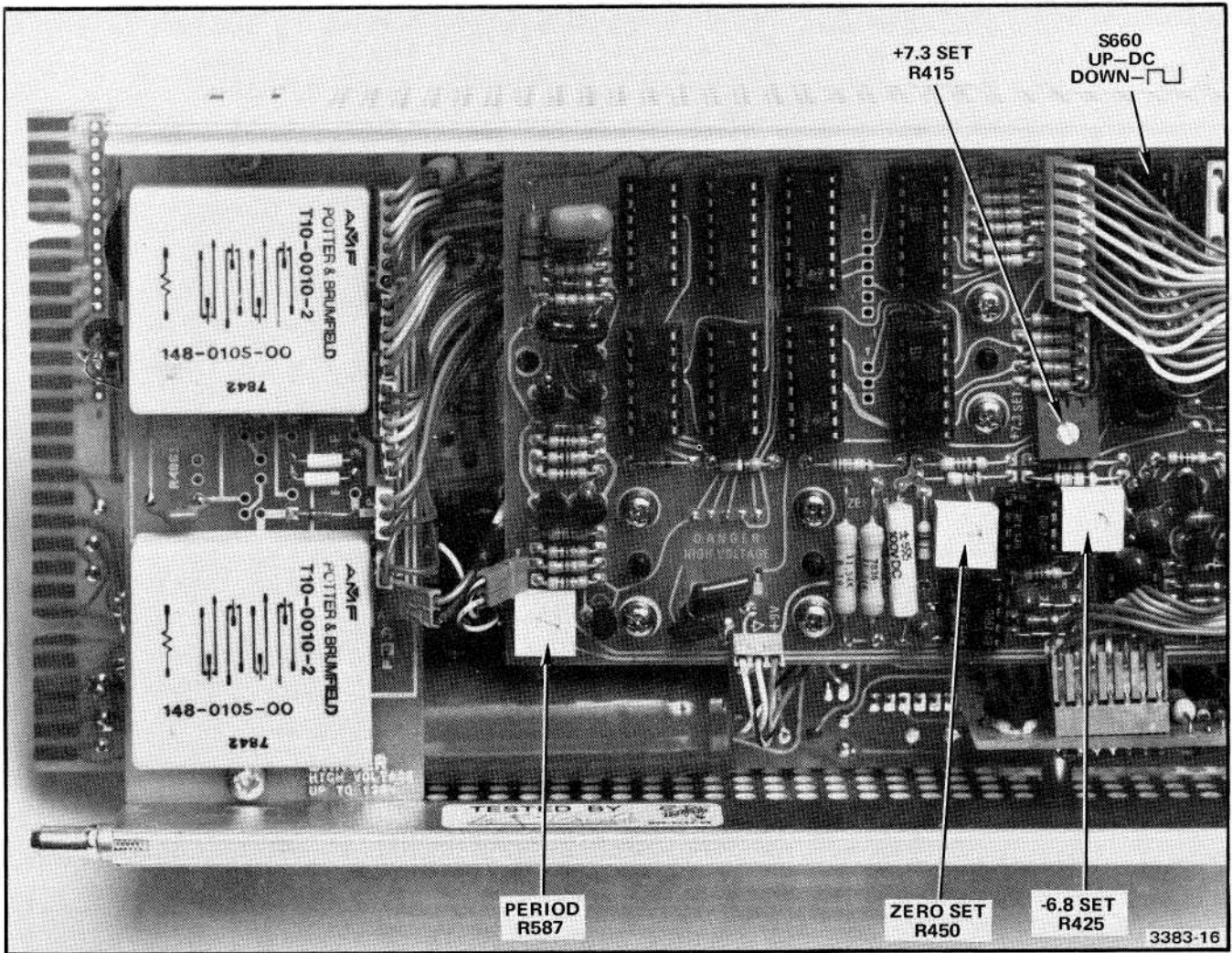

Fig. 4-6. Adjustment locations for the A2 DVM/Period circuit board.

b. Using a precision 50 Ω coaxial cable, connect the PG 506 AMPL OUTPUT HIGH or STD to the 1 MΩ voltmeter input.

c. Examine—for a reading of +99.99 Vdc to +100.01 Vdc.

d. Adjust—100 V Set (R205) for 100.00 Vdc.

e. Set the PG 506 AMPLITUDE control to 10.

f. Adjust—10 V Set (R340) for 10.00 Vdc.

g. Set the precision volt/ohmmeter to read 100 Vdc.

h. Repeat parts c thru f to minimize the effect of interaction.

4. Adjust DEFLECTION ERROR % Readout

Set the following controls as indicated:

PG 506

Function	STD AMPL
AMPLITUDE	100
VARIABLE (OUT)	out

a. Set the precision volt/ohmmeter to measure 100 Vdc.

b. Using the VARIABLE (OUT) control, set the output voltage reading on the precision volt/ohmmeter to 100.00 Vdc.

c. Examine—the DEFLECTION ERROR % readout is 0.1, with the HIGH or LOW lamp lit.

d. Adjust—Zero Set (R450) for a 0.0% reading. Refer to Fig. 4-6.

e. Using the VARIABLE (OUT) control, set the output voltage reading to 107.3 Vdc.

f. Examine—the DEFLECTION ERROR % readout is 6.7 to 6.9 with the LOW lamp lit.

g. Adjust—6.8 Set (R425) for a 6.8 reading. Refer to Fig. 4-6.

h. Using the VARIABLE (OUT) control, set the output voltage reading to 93.2 Vdc.

i. Examine—the DEFLECTION ERROR % readout is 7.2 to 7.4, with the HIGH lamp lit.

j. Adjust—+7.3 Set (R415) for a 7.3 reading. Refer to Fig. 4-6.

k. Disconnect the precision volt/ohmmeter connections.

l. Return the DC—Pulse switch (S660) to Pulse (down).

5. Adjust STD AMPL Output Period

Set the following controls as indicated:

PG 506

Function	STD AMPL
AMPLITUDE	20
VARIABLE (OUT)	in

Test Oscilloscope

Volts/Div	5
Time/Div	.2 ms

a. Using a 50 Ω coaxial cable, connect the AMPL OUTPUT HIGH or STD to the test oscilloscope vertical input.

Calibration Procedure—PG 506 (SN B040000 & up)

Adjustment Procedure

b. Using the test oscilloscope triggering controls, obtain a stable display.

c. Examine—for one complete cycle in 4.9 to 5.1 divisions.

d. Adjust—Period (R587) for one complete cycle in 5 divisions. Refer to Fig. 4-6.

6. Adjust Max Ampl Output Set

Set the following controls as indicated:

PG 506

Function	HIGH AMPL
PERIOD	1 μs 1 MHz
VAR	ccw
PULSE AMPLITUDE	MAX

Test Oscilloscope

Volts/Div	1 V
Time/Div	1 μs

a. Using a 50 Ω coaxial cable and 50 Ω termination, connect the AMPL OUTPUT HIGH or STD to the test oscilloscope vertical input.

b. Examine—the peak-to-peak amplitude is 5.2 to 5.3 divisions.

c. Adjust—Max Ampl Set (R790) for a peak-to-peak amplitude of 5.2 divisions.

7. Adjust Fast Rise Output Amplitude

Set the following controls as indicated:

PG 506

Function	FAST RISE
PULSE AMPLITUDE	MIN

Test Oscilloscope

Volts/Div	50 mV
Time/Div	1 μs

a. Using a 50 Ω coaxial cable and 50 Ω termination, connect the positive-going FAST RISE OUTPUTS connector to the test oscilloscope vertical input. Note the peak-to-peak signal amplitude.

Calibration Procedure—PG 506 (SN B040000 & up)
Adjustment Procedure

b. Change the connection to the negative-going FAST RISE OUTPUTS connector. Note the peak-to-peak signal amplitude.

c. Examine—the two noted peak-to-peak signal amplitudes are ≥ 50 mV and ≤ 100 mV.

d. Adjust—Min Ampl (R1025) for positive-going and negative-going FAST RISE OUTPUTS signal amplitude of ≥ 50 mV and ≤ 100 mV. Refer to Fig. 4-7.

e. Set PULSE AMPLITUDE to MAX.

f. Examine—positive-going and negative-going FAST RISE OUTPUTS are ≥ 1 V peak-to-peak.

Sampling System

mV/Div	100
Variable (CAL in)	in
+Up	in
Dot Response	midrange
Normal	in
Time Pos Rng	.5 μ s
Time/Div	1 ns
Sequential	in
Slope	– (minus in)
Trig Amp	X1
Trig Input	Ext 50 Ω 2 V Max

a. Using a precision 50 Ω coaxial cable, a 50 Ω 2X attenuator, and a bnc female to sma male adapter, connect the positive-going FAST RISE OUTPUTS connector to the S-6 input.

b. Using the necessary adapters and 18" 50 Ω coaxial cable, connect the S-6 loop thru to the 7T11 external trigger input.

c. Using the 7T11 triggering and time position controls, locate the positive-going step in the display area.

8. Adjust Fast Rise Output Aberrations

Set the following controls as indicated:

PG 506

Function	FAST RISE
PERIOD	1 μ s 1 MHz
VAR	ccw
PULSE AMPLITUDE	MAX

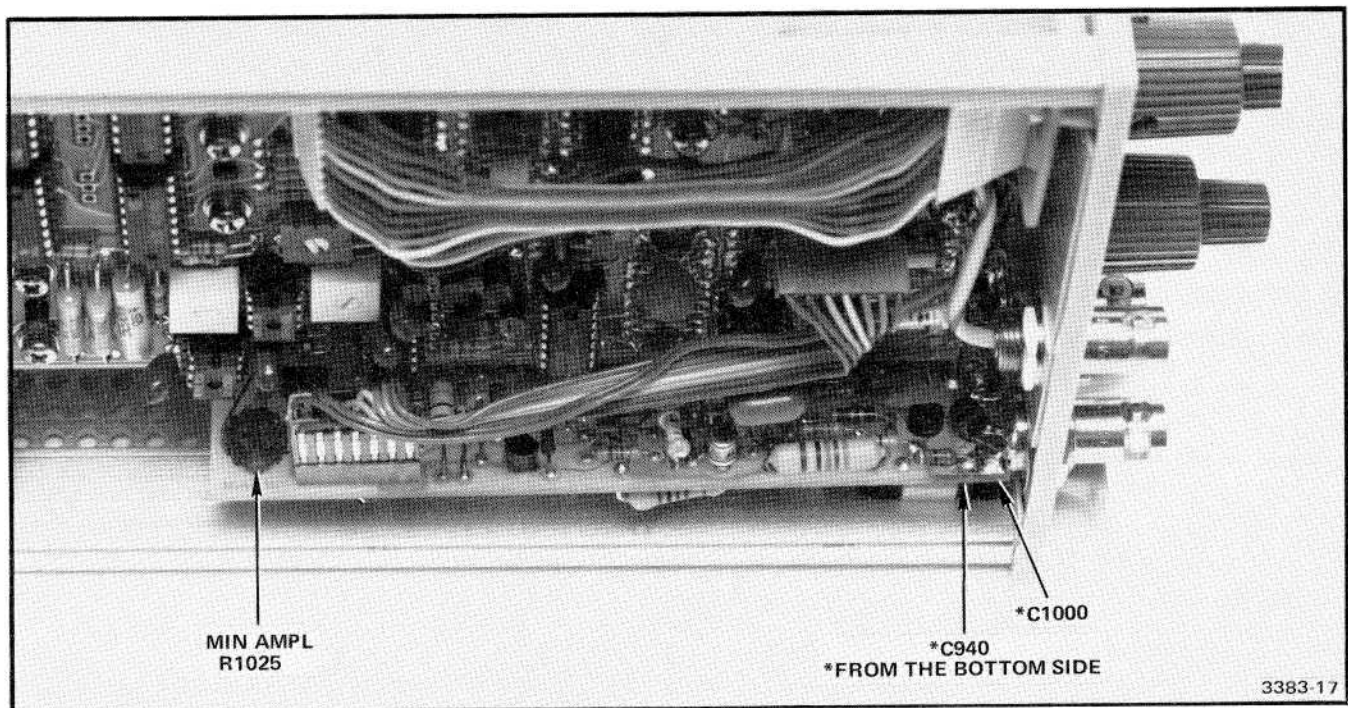

Fig. 4-7. Adjustment locations for the A3 Fast Rise Output circuit board.

**Calibration Procedure—PG 506 (SN B040000 & up)
Adjustment Procedure**

- d. Using the 7S11 vertical deflection variable control, obtain a display peak-to-peak amplitude of 5 divisions.
- e. Set the mV/Div to 10. Do not change the variable setting.
- f. Using the 7S11 Dc Offset, align the waveform near the center of the display area.
- g. Examine—the positive-going pulse aberrations are 1 division. Refer to Fig. 4-8.
- h. Adjust—C1000 for minimum aberrations with risetime ≤ 1 ns. A slight amount of front-cover overshoot is desirable.

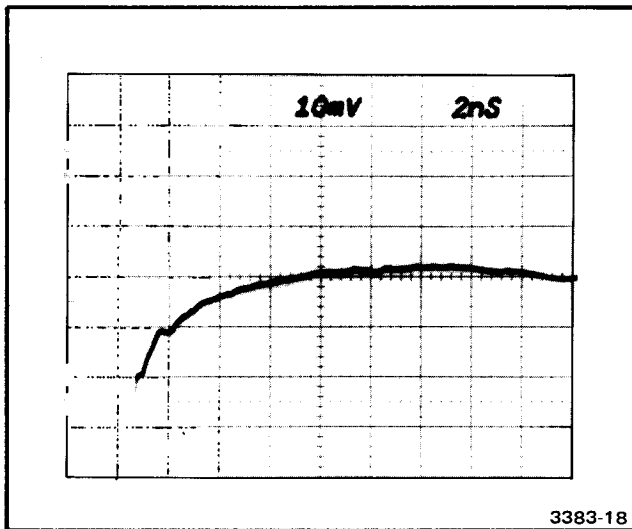

Fig. 4-8. Typical response curve as displayed on the sampling system.

- i. Disconnect the precision coaxial cable from the positive-going FAST RISE OUTPUTS connector and connect it to the negative-going FAST RISE OUTPUTS connector.
- j. Set the 7S11 mV/Div to 100 mV and the +Up/Invert switch to Invert.
- k. Repeat parts c thru g of this step.
- l. Adjust—C940 for minimum aberrations with risetime ≤ 1 ns. A slight amount of front-corner overshoot is desirable. Refer to Fig. 4-9.

This completes the Adjustment Procedure.

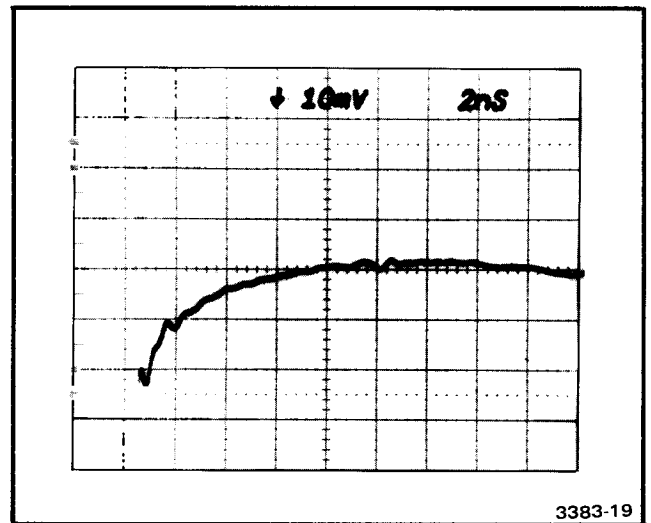

Fig. 4-9. Typical response curve as displayed on the sampling oscilloscope.

MAINTENANCE

Preventive Maintenance

There are no special preventive maintenance procedures, other than care during handling, calibration, installation, and removal.

Corrective Maintenance

General. For general corrective maintenance procedures and instructions refer to the power module instruction manual.

J950 or J1010 Replacement. If either J950 or J1010 is to be replaced, the resistor that is soldered to the rear of the connector (R950 and R1010 respectively) should also be

replaced. Attempts to remove these resistors usually result in damage to their disc-type body. If J950 or J1010 is replaced without the resistor there will probably be a termination aberration visible approximately 9 ns from the front corner of the output pulse.

Selected Components Criteria

During initial calibration selected values of the following components may have been installed to meet certain performance requirements for this instrument. If, during recalibration following corrective maintenance or hours-of-service performance checks, it is determined that one or more of these components needs replacement the following criteria (Table 5-1) should be used.

Table 5-1

SELECTED COMPONENT CRITERIA

Component	Circuit Involved	Range of Values	Criteria/Effects
R940, R1000	Fast Rise Outputs	68 Ω to 220 Ω	Selected for optimum risetime and minimum aberrations. An increase of resistance increases risetime.
R937	Fast Rise Outputs	24 Ω to 220 Ω	Matches maximum negative-going output to maximum positive-going output within 20 mV. Maximum negative-going output increases as resistance increases.
R757	High Amplitude Output	68 Ω to 330 Ω	Selected for optimum risetime and minimum aberrations. A decrease of resistance decreases risetime. A decrease of capacitance decreases risetime.
C755	High Amplitude Output	5 pF to 33 pF	
R315	Standard Amplitude Output	7 k Ω to 25k Ω	Use a precision ohmmeter between the AMPL OUTPUT HIGH or STD connector and chassis ground with AMPLITUDE set to 10 V and mode set to STD AMPL. Select resistor for a reading of 50 Ω within 0.5%.

20 mA Current Source

A 20 mA current source is needed for the adjustment of the PG 506. Another PG 506, if available, can be used for this purpose by using the AMPL OUTPUT connector, setting the AMPLITUDE control to 2 V, and adjusting the VARIABLE (OUT) control in STD AMPL mode.

If another PG 506 is not available a 20 mA current source approximation can be constructed by inserting a 931 Ω , 1% resistor and a 50 Ω potentiometer in series with a 20 V supply.

Circuit Board Removal

A2-DVM. Note the location of all connectors attached to the front of the board and remove. Remove the ten screws that hold the board to the MAIN board-A1. Lift the board up and out of the mainframe. Note the location of the connectors attached to the rear of the board and remove. To replace the board reverse this procedure.

A5-Relay. Note the location of all connectors attached to the board and remove. Remove the two screws that attach the board to the spacers from the frame. Reverse the procedure to replace the board.

A1-Main. To remove A1, first remove A2 and A5. With A2 and A5 removed, remove the PULSE AMPLITUDE knob, PERIOD knob, and mode switch knob. Note the location of all connectors and disconnect. Remove the screw that attaches the heat sink for Q758 to the top of the frame. Remove the two spacer screws at the rear of the instrument and the two screws towards the front of the instrument. Remove the board through the rear of the instrument. Reverse this procedure to replace the board.

A3-Fast Rise. Note the location of the connectors and remove. Remove the retaining nuts on the front-panel bnc connectors labeled FAST RISE OUTPUTS. Slide the board back until the bnc connectors clear the front panel. Remove the board from the frame. Reverse this procedure to replace the board.

A4-Display. Note the location of all connectors and remove. Remove the two screws that attach the board to the front panel. Remove the five screws that attach A1 to the frame and slide A1 towards the rear of the instrument. Pull A4 out through the side of the frame. Reverse this procedure to replace the board.

Obtaining Replacement Parts

Most electrical and mechanical parts can be obtained through your local Tektronix field office or representative.

However, you should be able to obtain many of the standard electronic components from a local commercial source. Before you purchase or order a part from a source other than Tektronix, Inc., please check the Replaceable Electrical Parts list for the proper value, rating, tolerance, and description.

Ordering Parts

When ordering parts from Tektronix, Inc., it is important that all of the following information be included to ensure receiving the proper parts.

1. Instrument type (including modification or option numbers).
2. Instrument serial number.
3. A description of the part (if electrical, include circuit number).
4. Tektronix part number.

Troubleshooting Aids

Refer to the power module instruction manual for a general discussion of aids in troubleshooting TM 500 Series equipment.

Interface Notes

The following information will aid the user in performing both corrective maintenance and in customizing the instrument.

Pin Assignments. Besides those pins used to connect the PG 506 to the power module (1-15, A & B), other pins are available to output signals to the interface so that they may be connected to other plug-ins through the interface. Fig. 5-1 shows the pins and their assignments.

CAUTION

When specialized rear interface wiring has been added to a Power Module compartment, the PG 506 may not be fully compatible with all other members of the signal source family. Trigger output (27B and 28B) and main output (28A and 27A) are compatible, as is the ground on 26B. The ground on 22A is not compatible with certain instruments, nor is the bcd information on 17B through 24B and the HIGH-LOW output on 16B. A plastic barrier (Tektronix Part Number 214-1593-02) should be installed in the key slot between contacts 23 and 24 on the power module. However, before inserting any other TM 500 signal source in a compartment with PG 506 interface wiring, check the diagrams in this book for pin-by-pin compatibility. Likewise, do not insert a PG 506 into a slot with rear interface wiring for any other signal source family connection without making the same compatibility check.

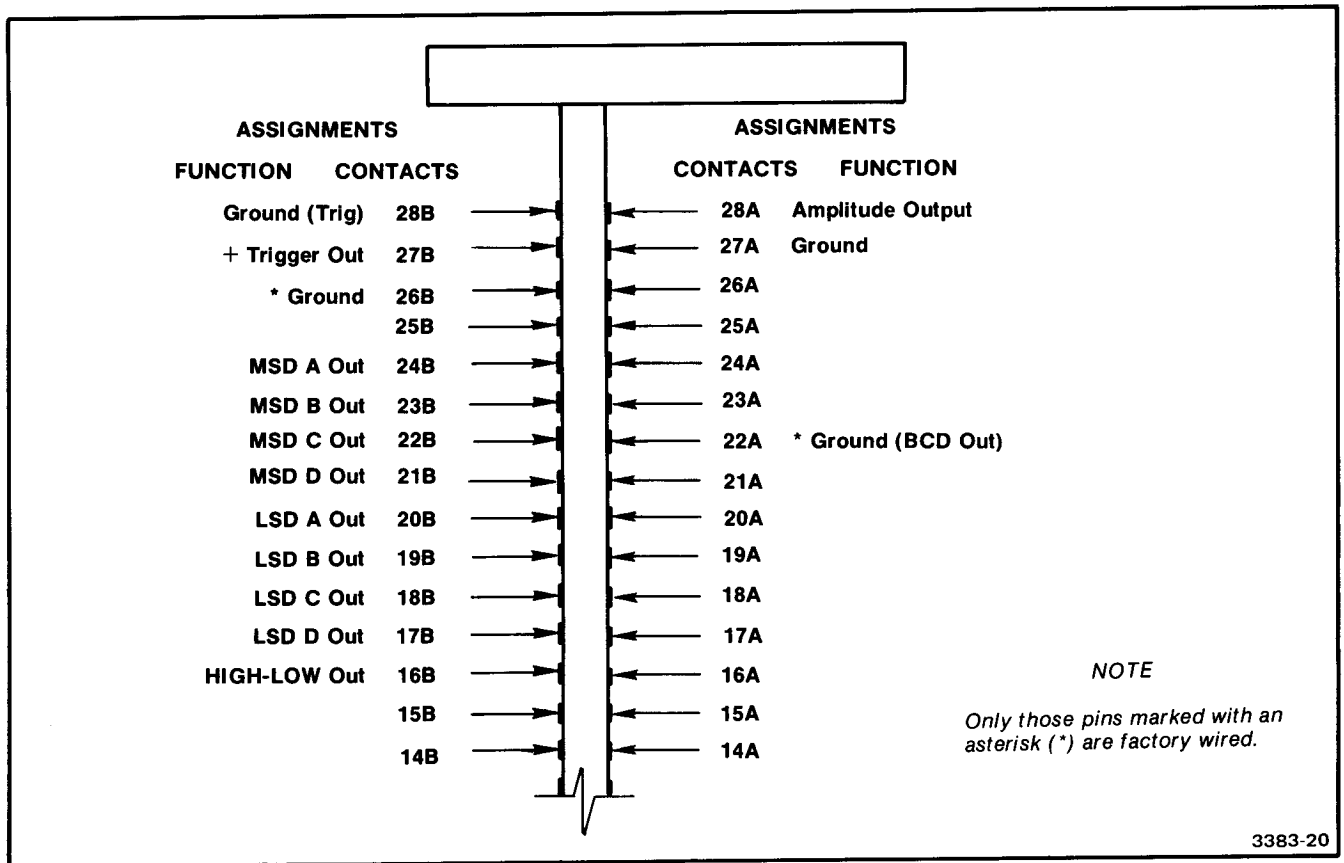

Fig. 5-1. Pin assignments for the PG 506 (rear view, partial).

Amplitude Output. To obtain the AMPL OUTPUT signal at the rear interface connectors, disconnect the coaxial cable from the main board (located in the lower left corner of the B side). Replace this cable with a miniature 50 Ω coaxial cable (Tektronix Part No. 175-1827-00). Remove the coaxial connector from the other end, and solder the cable to the rear interface connector as follows:

- Shield to 27A (3rd hole down from top on the B side)
- Center conductor to 28A (4th hole down on the B side)

See Fig. 5-2 for pictorial interface connection detail.

NOTE

Connecting front panel signals to the rear interface will degrade their performance slightly.

Trigger Output. To connect TRIG OUT to the rear interface, disconnect the coaxial 50 Ω lead to the front panel at the DVM board end (located in the upper right corner as viewed from the rear). Replace this cable with a miniature 50 Ω coaxial cable (Tektronix Part Number 175-1826-00). Remove the coaxial connector from the other end, and solder the cable to the rear interface connector as follows:

- Shield to 28 B (2nd hole down from top on the A side)
- Center Conductor to 27B (5th hole down on the A side)

See Fig. 5-2 for pictorial interface connection detail.

NOTE

Ground connections to 26B and 22A are the only rear interface signal connections that are factory wired.

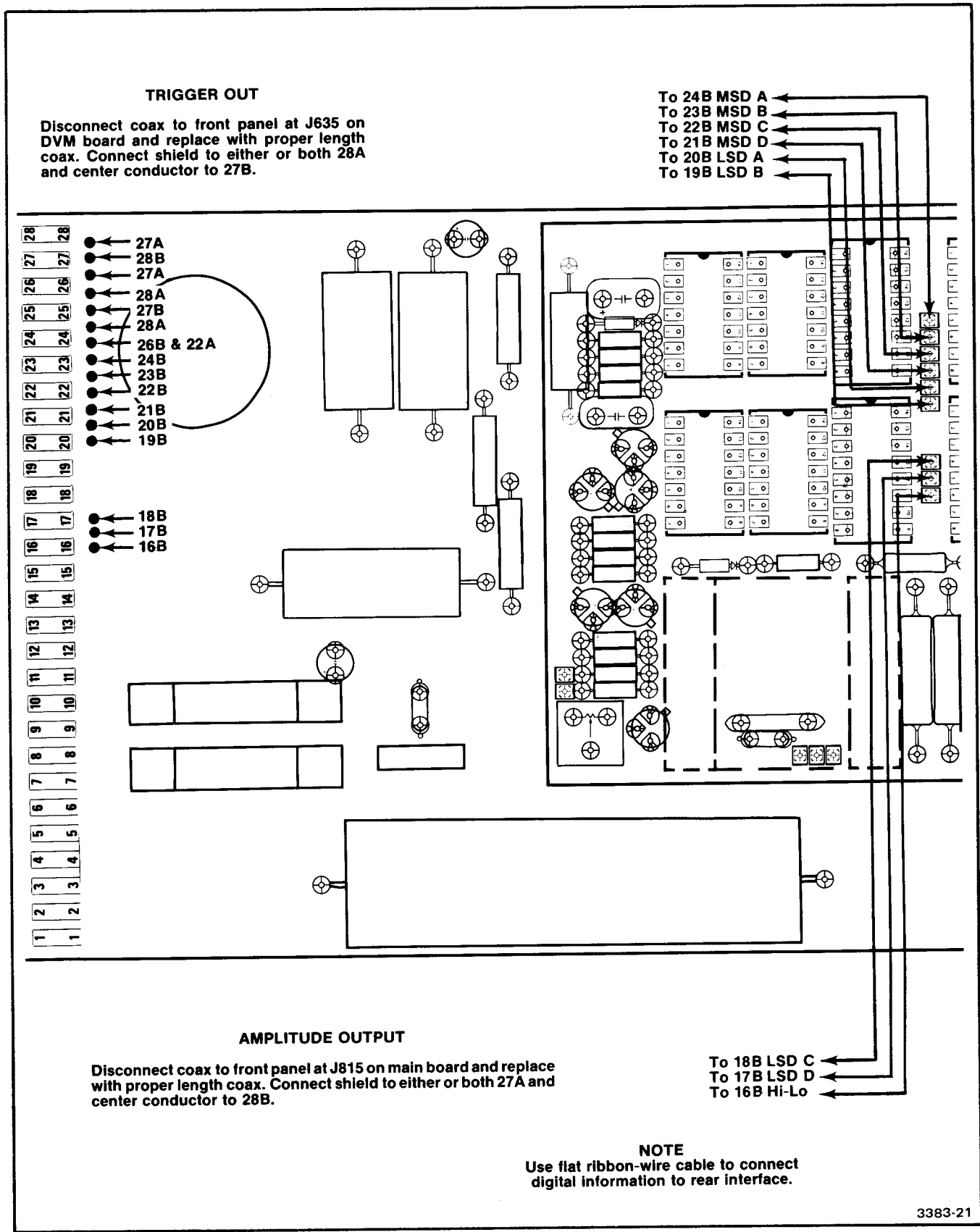

Fig. 5-2. Main interface board (partial) showing amplitude and trigger output cable connections.

MSD & LSD Outputs. To obtain readout information at the interface, use flat ribbon-wire to connect this digital information to the through-plated holes as shown in Fig. 5-2 and according to the following list:

- | | | |
|--------------|---|-------------------------|
| MSD A to 24B | } | 6 lead flat ribbon-wire |
| MSD B to 23B | | |
| MSD C to 22B | | |
| MSD D to 21B | | |
| LSD A to 20B | | |
| LSD B to 19B | | |
| LSD C to 18B | } | 3 lead flat ribbon-wire |
| LSD D to 17B | | |
| Hi-Lo to 16B | | |

NOTE

Each of the MSD and LSD outputs is only capable of driving one TTL load. The active level of each output is high.

For the Hi-Lo Output, output is low when the HIGH display light on the front panel is on.

Static-Sensitive Components



Static discharge can damage any semiconductor component in this instrument.

This instrument contains electrical components that are susceptible to damage from static discharge. See Table 5-2 for relative susceptibility of various classes of semiconductors. Static voltages of 1 kB to 30 kB are common in unprotected environments.

Observe the following precautions to avoid damage:

1. Minimize handling of static-sensitive components.
2. Transport and store static-sensitive components or assemblies in their original containers, on a metal rail, or on conductive foam. Label any package that contains static-sensitive assemblies or components.
3. Discharge the static voltage from your body by wearing a wrist strap while handling these com-

ponents. Servicing static-sensitive assemblies or components should be performed only at a static-free work station by qualified service personnel.

4. Nothing capable of generating or holding a static charge should be allowed on the work station surface.
5. Keep the component leads shorted together whenever possible.
6. Pick up components by the body, never by the leads.
7. Do not slide the components over any surface.
8. Avoid handling components in areas that have a floor or work-surface covering capable of generating a static charge.
9. Use a soldering iron that is connected to earth ground.
10. Use only special antistatic suction type or wick type desoldering tools.

Table 5-2

RELATIVE SUSCEPTIBILITY TO STATIC DISCHARGE DAMAGE

Semiconductor Classes	Relative Susceptibility Levels ^a
MOS or CMOS microcircuits or discretes, or linear microcircuits with MOS inputs. (Most Sensitive)	1
ECL	2
Schottky signal diodes	3
Schottky TTL	4
High-frequency bipolar transistors	5
JFETs	6
Linear microcircuits	7
Low-power Schottky TTL	8
TTL (Least Sensitive)	9

^a Voltage equivalent for levels:

- | | | |
|------------------|------------------|-------------------------|
| 1 = 100 to 500 V | 4 = 500 V | 7 = 400 to 1000 V(est.) |
| 2 = 200 to 500 V | 5 = 400 to 600 V | 8 = 900 V |
| 3 = 250 V | 6 = 600 to 800 V | 9 = 1200 V |
- (Voltage discharge from a 100 pF capacitor through a resistance of 100 ohms.)

OPTIONS

There are no options for the PG 506 at the time of this printing.

REPLACEABLE ELECTRICAL PARTS

PARTS ORDERING INFORMATION

Replacement parts are available from or through your local Tektronix, Inc. Field Office or representative.

Changes to Tektronix instruments are sometimes made to accommodate improved components as they become available, and to give you the benefit of the latest circuit improvements developed in our engineering department. It is therefore important, when ordering parts, to include the following information in your order: Part number, instrument type or number, serial number, and modification number if applicable.

If a part you have ordered has been replaced with a new or improved part, your local Tektronix, Inc. Field Office or representative will contact you concerning any change in part number.

Change information, if any, is located at the rear of this manual.

SPECIAL NOTES AND SYMBOLS

X000 Part first added at this serial number
00X Part removed after this serial number

ITEM NAME

In the Parts List, an Item Name is separated from the description by a colon (:). Because of space limitations, an Item Name may sometimes appear as incomplete. For further Item Name identification, the U.S. Federal Cataloging Handbook H6-1 can be utilized where possible.

ABBREVIATIONS

ACTR	ACTUATOR	PLSTC	PLASTIC
ASSY	ASSEMBLY	QTZ	QUARTZ
CAP	CAPACITOR	RECP	RECEPTACLE
CER	CERAMIC	RES	RESISTOR
CKT	CIRCUIT	RF	RADIO FREQUENCY
COMP	COMPOSITION	SEL	SELECTED
CONN	CONNECTOR	SEMICOND	SEMICONDUCTOR
ELCTLT	ELECTROLYTIC	SENS	SENSITIVE
ELEC	ELECTRICAL	VAR	VARIABLE
INCAND	INCANDESCENT	WW	WIREWOUND
LED	LIGHT EMITTING DIODE	XFMR	TRANSFORMER
NONWIR	NON WIREWOUND	XTAL	CRYSTAL

Replaceable Electrical Parts—PG 508(SN B040000-Up)

CROSS INDEX—MFR. CODE NUMBER TO MANUFACTURER

Mfr. Code	Manufacturer	Address	City, State, Zip
00853	SANGAMO ELECTRIC CO., S. CAROLINA DIV.	P.O. BOX 128	PICKENS, SC 29671
01121	ALLEN-BRADLEY COMPANY	1201 2ND STREET SOUTH	MILWAUKEE, WI 53204
01295	TEXAS INSTRUMENTS, INC. SEMICONDUCTOR GROUP	P.O. BOX 5012	DALLAS, TX 75222
02111	SPECTROL ELECTRONICS CORPORATION	17070 EAST GALE AVENUE	CITY OF INDUSTRY, CA 91745
02735	RCA CORPORATION, SOLID STATE DIVISION	ROUTE 202	SOMERVILLE, NY 08876
03508	GENERAL ELECTRIC COMPANY, SEMI-CONDUCTOR PRODUCTS DEPARTMENT	ELECTRONICS PARK	SYRACUSE, NY 13201
03888	KDI PYROFILM CORPORATION	60 S JEFFERSON ROAD	WHIPPANY, NJ 07981
04222	AVX CERAMICS, DIVISION OF AVX CORP.	P O BOX 867	MYRTLE BEACH, SC 29577
04713	MOTOROLA, INC., SEMICONDUCTOR PROD. DIV.	5005 E MCDOWELL RD,PO BOX 20923	PHOENIX, AZ 85036
05397	UNION CARBIDE CORPORATION, MATERIALS SYSTEMS DIVISION	11901 MADISON AVENUE	CLEVELAND, OH 44101
07263	FAIRCHILD SEMICONDUCTOR, A DIV. OF FAIRCHILD CAMERA AND INSTRUMENT CORP.	464 ELLIS STREET	MOUNTAIN VIEW, CA 94042
08806	GENERAL ELECTRIC CO., MINIATURE LAMP PRODUCTS DEPARTMENT	NELA PARK	CLEVELAND, OH 44112
14433	ITT SEMICONDUCTORS	3301 ELECTRONICS WAY P O BOX 3049	WEST PALM BEACH, FL 33402 SANTA ANA, CA 92704
14552	MICRO SEMICONDUCTOR CORP.	2830 E FAIRVIEW ST.	HICKSVILLE, NY 11802
14936	GENERAL INSTRUMENT CORP., SEMICONDUCTOR PRODUCTS GROUP	P.O. BOX 600,600 W. JOHN ST.	GREENWOOD, IN 46142
24931	SPECIALITY CONNECTOR CO., INC.	2620 ENDRESS PLACE	SANTA CLARA, CA 95051
27014	NATIONAL SEMICONDUCTOR CORP.	2900 SEMICONDUCTOR DR.	TUCSON, AZ 85706
32159	WEST-CAP ARIZONA	2201 E. ELVIRA ROAD	RIVERSIDE, CA 92507
32997	BOURNS, INC., TRIMPOT PRODUCTS DIV.	1200 COLUMBIA AVE.	PALO ALTO, CA 94304
50434	HEWLETT-PACKARD COMPANY	640 PAGE MILL ROAD	CAZENOVIA, NY 13035
52763	STETTNER-TRUSH, INC.	67 ALBANY STREET	NORTH ADAMS, MA 01247
56289	SPRAGUE ELECTRIC CO.	87 MARSHALL ST.	IRVINE, CA 92713
57668	R-OHM CORP.	16931 MILLIKEN AVE.	TUCSON, AZ 85705
59660	TUSONIX INC.	2155 N FORBES BLVD	ST. LOUIS, MO 63107
71400	BUSSMAN MFG., DIVISION OF MCGRAW-EDISON CO.	2536 W. UNIVERSITY ST.	ERIE, PA 16512
72982	ERIE TECHNOLOGICAL PRODUCTS, INC.	644 W. 12TH ST.	FULLERTON, CA 92634
73138	BECKMAN INSTRUMENTS, INC., HELIPOT DIV.	2500 HARBOR BLVD.	PHILADELPHIA, PA 19108
75042	TRW ELECTRONIC COMPONENTS, IRC FIXED RESISTORS, PHILADELPHIA DIVISION	401 N. BROAD ST.	PRINCETON, IN 47670
77342	AMF INC., POTTER AND BRUMFIELD DIV.	200 RICHLAND CREEK DRIVE	WARMINISTER, PA 18974
79727	C-W INDUSTRIES	550 DAVISVILLE RD.,P O BOX 96	BEAVERTON, OR 97077
80009	TEKTRONIX, INC.	P O BOX 500	INDIANAPOLIS, IN 46206
90201	MALLORY CAPACITOR CO., DIV. OF P. R. MALLORY AND CO., INC.	3029 E. WASHINGTON STREET	COLUMBUS, NE 68601
91637	DALE ELECTRONICS, INC.	P. O. BOX 372	SAN FERNANDO, CA 91341
96733	SAN FERNANDO ELECTRIC MFG CO	P. O. BOX 609	
		1501 FIRST ST	

Replaceable Electrical Parts—PG 506(SN B040000-Up)

Kct No.	Tektronix Part No.	Serial/Model No. Eff	Dscont	Name & Description	Mfr Code	Mfr Part Number
A1	670-3230-08			CKT BOARD ASSY:MAIN	80009	670-3230-08
A2	670-3234-04			CKT BOARD ASSY:DVM/PERIOD	80009	670-3234-04
A3	670-3452-02	B040000	B058179	CKT BOARD ASSY:FAST RISE	80009	670-3452-02
A3	670-3452-03	B058180		CKT BOARD ASSY:FAST RISE	80009	670-3452-03
A4	670-3314-00			CKT BOARD ASSY:DISPLAY	80009	670-3314-00
A5	670-4328-00			CKT BOARD ASSY:RELAY	80009	670-4328-00
C3	283-0178-00			CAP.,FXD,CER DI:0.1UF,+80-20%,100V	72982	8131N145651 104Z
C10	290-0714-00			CAP.,FXD,ELCTLT:2000UF,+75-10%,40V	56289	39D641
C15	283-0134-00			CAP.,FXD,CER DI:0.47UF,+80-20%,50V	72982	8131N087Z5U0474Z
C20	283-0194-00			CAP.,FXD,CER DI:4.7UF,20%,50V	56289	5C37Z5U475M050B
C22	281-0814-00			CAP.,FXD,CER DI:100PF,10%,100V	04222	GC101A101K
C27	290-0525-00			CAP.,FXD,ELCTLT:4.7UF,20%,50V	56289	196D475X0050KA1
C30	283-0167-00			CAP.,FXD,CER DI:0.1UF,10%,100V	72982	8131N145X5R0104K
C32	290-0559-00			CAP.,FXD,ELCTLT:22UF,20%,35V	90201	TDC226M035WLG
C34	290-0559-00			CAP.,FXD,ELCTLT:22UF,20%,35V	90201	TDC226M035WLG
C36	290-0117-00			CAP.,FXD,ELCTLT:50UF,+75-10%,50V	56289	30D506G050DD9
C40	283-0134-00			CAP.,FXD,CER DI:0.47UF,+80-20%,50V	72982	8131N087Z5U0474Z
C42	283-0198-00			CAP.,FXD,CER DI:0.22UF,20%,50V	56289	1C10Z5U223M050B
C45	281-0775-00			CAP.,FXD,CER DI:0.1UF,20%,50V	04222	MA205E104MAA
C46	283-0177-00	B046760		CAP.,FXD,CER DI:1UF,+80-20%,25V	56289	2C20Z5U105Z025B
C65	290-0529-00			CAP.,FXD,ELCTLT:47UF,20%,20V	05397	T362C476M020AS
C67	290-0529-00			CAP.,FXD,ELCTLT:47UF,20%,20V	05397	T362C476M020AS
C75	283-0134-00			CAP.,FXD,CER DI:0.47UF,+80-20%,50V	72982	8131N087Z5U0474Z
C78	290-0525-00			CAP.,FXD,ELCTLT:4.7UF,20%,50V	56289	196D475X0050KA1
C80	281-0810-00			CAP.,FXD,CER DI:5.6PF,0.5%,100V	04222	GC10-1A5R6D
C90	283-0051-00			CAP.,FXD,CER DI:0.0033UF,5%,100V	56289	1C20C0G332J100B
C100	281-0775-00			CAP.,FXD,CER DI:0.1UF,20%,50V	04222	MA205E104MAA
C125	281-0810-00			CAP.,FXD,CER DI:5.6PF,0.5%,100V	04222	GC10-1A5R6D
C135	290-0405-00			CAP.,FXD,ELCTLT:10UF,+50-10%,150V	56289	30D106F150DD2
C140	283-0057-00			CAP.,FXD,CER DI:0.1UF,+80-20%,200V	56289	2C20Z5U104Z200B
C145	290-0159-00			CAP.,FXD,ELCTLT:2UF,+50-10%,150V	56289	30D205F150BB9
C150	290-0159-00			CAP.,FXD,ELCTLT:2UF,+50-10%,150V	56289	30D205F150BB9
C154	283-0167-00			CAP.,FXD,CER DI:0.1UF,10%,100V	72982	8131N145X5R0104K
C165	290-0525-00			CAP.,FXD,ELCTLT:4.7UF,20%,50V	56289	196D475X0050KA1
C170	290-0719-00			CAP.,FXD,ELCTLT:47UF,20%,25V	56289	196D476X0025TE3
C175	290-0525-00			CAP.,FXD,ELCTLT:4.7UF,20%,50V	56289	196D475X0050KA1
C180	290-0719-00			CAP.,FXD,ELCTLT:47UF,20%,25V	56289	196D476X0025TE3
C190	290-0442-00			CAP.,FXD,ELCTLT:120UF,+75-10%,150V	56289	39D1197
C196	281-0775-00			CAP.,FXD,CER DI:0.1UF,20%,50V	04222	MA205E104MAA
C198	281-0775-00			CAP.,FXD,CER DI:0.1UF,20%,50V	04222	MA205E104MAA
C200	290-0117-00			CAP.,FXD,ELCTLT:50UF,+75-10%,50V	56289	30D506G050DD9
C210	290-0534-00			CAP.,FXD,ELCTLT:1UF,20%,35V	56289	196D105X0035HA1
C212	283-0167-00			CAP.,FXD,CER DI:0.1UF,10%,100V	72982	8131N145X5R0104K
C237	283-0208-00			CAP.,FXD,CER DI:0.22UF,10%,200V	72982	8151N230 C 224K
C240	281-0775-00			CAP.,FXD,CER DI:0.1UF,20%,50V	04222	MA205E104MAA
C247	281-0523-00			CAP.,FXD,CER DI:100PF,+/-20PF,500V	72982	301-000U2M0101M
C294	290-0405-00			CAP.,FXD,ELCTLT:10UF,+50-10%,150V	56289	30D106F150DD2
C295	283-0057-00			CAP.,FXD,CER DI:0.1UF,+80-20%,200V	56289	2C20Z5U104Z200B
C315	283-0198-00			CAP.,FXD,CER DI:0.22UF,20%,50V	56289	1C10Z5U223M050B
C317	281-0638-00			CAP.,FXD,CER DI:240PF,5%,500V	72982	301000Z5D241J
C318	281-0773-00			CAP.,FXD,CER DI:0.01UF,10%,100V	04222	MA201C103KAA
C330	281-0775-00			CAP.,FXD,CER DI:0.1UF,20%,50V	04222	MA205E104MAA

Replaceable Electrical Parts—PG 506(SN B040000-Up)

Ckt No.	Tektronix	Serial/Model No.		Name & Description	Mfr	Mfr Part Number
	Part No.	Eff	Dscont		Code	
C365	290-0529-00			CAP.,FXD,ELCTLT:47UF,20%,20V	05397	T362C476M020AS
C370	290-0215-00			CAP.,FXD,ELCTLT:100UF,+75-10%,25V	56289	30D107G025DD9
C375	281-0775-00			CAP.,FXD,CER DI:0.1UF,20%,50V	04222	MA205E104MAA
C380	281-0775-00			CAP.,FXD,CER DI:0.1UF,20%,50V	04222	MA205E104MAA
C390	283-0211-00			CAP.,FXD,CER DI:0.1UF,10%,200V	04222	SR406C104KAA
C392	283-0024-00			CAP.,FXD,CER DI:0.1UF,+80-20%,50V	72982	8121N083Z5U0104Z
C400	290-0519-00			CAP.,FXD,ELCTLT:100UF,20%,20V	90201	TDC107M020WLD
C420	290-0536-00			CAP.,FXD,ELCTLT:10UF,20%,25V	90201	TDC106M025FL
C435	290-0536-00			CAP.,FXD,ELCTLT:10UF,20%,25V	90201	TDC106M025FL
C460	290-0536-00			CAP.,FXD,ELCTLT:10UF,20%,25V	90201	TDC106M025FL
C462	285-0683-00			CAP.,FXD,PLSTC:0.022UF,5%,100V	56289	192P22352
C465	290-0536-00			CAP.,FXD,ELCTLT:10UF,20%,25V	90201	TDC106M025FL
C470	290-0536-00			CAP.,FXD,ELCTLT:10UF,20%,25V	90201	TDC106M025FL
C474	290-0536-00			CAP.,FXD,ELCTLT:10UF,20%,25V	90201	TDC106M025FL
C480	290-0536-00			CAP.,FXD,ELCTLT:10UF,20%,25V	90201	TDC106M025FL
C500	283-0065-00			CAP.,FXD,CER DI:0.001UF,5%,100V	59660	0835-591Y5EO102J
C506	283-0065-00			CAP.,FXD,CER DI:0.001UF,5%,100V	59660	0835-591Y5EO102J
C520	283-0065-00			CAP.,FXD,CER DI:0.001UF,5%,100V	59660	0835-591Y5EO102J
C558	281-0543-00			CAP.,FXD,CER DI:270PF,10%,500V	72982	301055X5P271K
C580	283-0666-00			CAP.,FXD,MICA D:890PF,2%,100V	00853	D151F891G0
C582	290-0574-00			CAP.,FXD,ELCTLT:47UF,10%,20V	90201	TDC476K020CL
C615	290-0519-00			CAP.,FXD,ELCTLT:100UF,20%,20V	90201	TDC107M020WLD
C718	281-0775-00			CAP.,FXD,CER DI:0.1UF,20%,50V	04222	MA205E104MAA
C732	290-0159-00			CAP.,FXD,ELCTLT:2UF,+50-10%,150V	56289	30D205F150BB9
C734	281-0775-00			CAP.,FXD,CER DI:0.1UF,20%,50V	04222	MA205E104MAA
C736	281-0775-00			CAP.,FXD,CER DI:0.1UF,20%,50V	04222	MA205E104MAA
C752	281-0540-00			CAP.,FXD,CER DI:51PF,5%,500V	59660	301-000U2J0510J
C755	281-0504-00			CAP.,FXD,CER DI:10PF,+/-1PF,500V	04222	7001-COG-100F
C755	-----			(NOMINAL VALUE,SELECTED)		
C764	283-0057-00			CAP.,FXD,CER DI:0.1UF,+80-20%,200V	56289	2C20Z5U104Z200B
C782	281-0775-00			CAP.,FXD,CER DI:0.1UF,20%,50V	04222	MA205E104MAA
C785	283-0057-00			CAP.,FXD,CER DI:0.1UF,+80-20%,200V	56289	2C20Z5U104Z200B
C792	281-0775-00			CAP.,FXD,CER DI:0.1UF,20%,50V	04222	MA205E104MAA
C800	281-0773-00			CAP.,FXD,CER DI:0.01UF,10%,100V	04222	MA201C103KAA
C818	281-0773-00			CAP.,FXD,CER DI:0.01UF,10%,100V	04222	MA201C103KAA
C840	281-0775-00			CAP.,FXD,CER DI:0.1UF,20%,50V	04222	MA205E104MAA
C886	281-0618-00			CAP.,FXD,CER DI:4.7PF,+/-0.5PF,200V	59660	374-018C0H0-479D
C904	283-0156-00			CAP.,FXD,CER DI:1000PF,+100-0%,200V	96733	R2670
C906	281-0613-00			CAP.,FXD,CER DI:10PF,+/-1PF,200V	59660	374018C0G0100
C914	283-0024-00			CAP.,FXD,CER DI:0.1UF,+80-20%,50V	72982	8121N083Z5U0104Z
C928	283-0024-00			CAP.,FXD,CER DI:0.1UF,+80-20%,50V	72982	8121N083Z5U0104Z
C938	283-0324-00			CAP.,FXD,CER DI:0.01UF,+80-20%,50V	04222	08055C103ZA2055
C940	281-0213-00			CAP.,VAR,CER DI:0.8-3.8PF,400V	52763	RT201-04SD.5/3.5
C962	283-0156-00			CAP.,FXD,CER DI:1000PF,+100-0%,200V	96733	R2670
C966	281-0613-00			CAP.,FXD,CER DI:10PF,+/-1PF,200V	59660	374018C0G0100
C974	283-0024-00			CAP.,FXD,CER DI:0.1UF,+80-20%,50V	72982	8121N083Z5U0104Z
C988	283-0024-00			CAP.,FXD,CER DI:0.1UF,+80-20%,50V	72982	8121N083Z5U0104Z
C998	283-0324-00			CAP.,FXD,CER DI:0.01UF,+80-20%,50V	04222	08055C103ZA2055
C1000	281-0213-00			CAP.,VAR,CER DI:0.8-3.8PF,400V	52763	RT201-04SD.5/3.5
C1026	290-0512-00			CAP.,FXD,ELCTLT:22UF,20%,15V	56289	196D226X0015KA1
C1028	290-0512-00			CAP.,FXD,ELCTLT:22UF,20%,15V	56289	196D226X0015KA1
C1034	283-0156-00			CAP.,FXD,CER DI:1000PF,+100-0%,200V	96733	R2670
C1045	283-0156-00			CAP.,FXD,CER DI:1000PF,+100-0%,200V	96733	R2670
C1060	283-0024-00			CAP.,FXD,CER DI:0.1UF,+80-20%,50V	72982	8121N083Z5U0104Z

Replaceable Electrical Parts—PG 506(SN B040000-Up)

Ckt No.	Tektronix Part No.	Serial/Model No. Eff Dscont	Name & Description	Mfr Code	Mfr Part Number
C1062	290-0527-00		CAP.,FXD,ELCTLT:15UF,20%,20V	90201	TDC156M020FL
C1065	283-0024-00		CAP.,FXD,CER DI:0.1UF,+80-20%,50V	72982	8121N083Z5U0104Z
C1067	290-0527-00		CAP.,FXD,ELCTLT:15UF,20%,20V	90201	TDC156M020FL
C1070	290-0527-00		CAP.,FXD,ELCTLT:15UF,20%,20V	90201	TDC156M020FL
CR1	152-0333-00		SEMICONV DEVICE:SILICON,55V,200MA	07263	FDH-6012
CR2	152-0333-00		SEMICONV DEVICE:SILICON,55V,200MA	07263	FDH-6012
CR10	152-0198-00		SEMICONV DEVICE:SILICON,200V,3A	03508	1N5624
CR11	152-0198-00		SEMICONV DEVICE:SILICON,200V,3A	03508	1N5624
CR22	152-0141-02		SEMICONV DEVICE:SILICON,30V,150MA	01295	1N4152R
CR27	152-0141-02		SEMICONV DEVICE:SILICON,30V,150MA	01295	1N4152R
CR38	152-0333-00		SEMICONV DEVICE:SILICON,55V,200MA	07263	FDH-6012
CR55	152-0141-02		SEMICONV DEVICE:SILICON,30V,150MA	01295	1N4152R
CR67	152-0066-00		SEMICONV DEVICE:SILICON,400V,750MA	14433	LG4016
CR70	152-0141-02		SEMICONV DEVICE:SILICON,30V,150MA	01295	1N4152R
CR78	152-0333-00		SEMICONV DEVICE:SILICON,55V,200MA	07263	FDH-6012
CR80	152-0574-00		SEMICONV DEVICE:SILICON,120V,0.15A	14433	WG1308
CR85	152-0574-00		SEMICONV DEVICE:SILICON,120V,0.15A	14433	WG1308
CR86	152-0141-02		SEMICONV DEVICE:SILICON,30V,150MA	01295	1N4152R
CR105	152-0141-02		SEMICONV DEVICE:SILICON,30V,150MA	01295	1N4152R
CR120	152-0574-00		SEMICONV DEVICE:SILICON,120V,0.15A	14433	WG1308
CR125	152-0574-00		SEMICONV DEVICE:SILICON,120V,0.15A	14433	WG1308
CR135	152-0586-00		SEMICONV DEVICE:SILICON,600V,500MA	14936	RGP10J-011
CR136	152-0586-00		SEMICONV DEVICE:SILICON,600V,500MA	14936	RGP10J-011
CR137	152-0586-00		SEMICONV DEVICE:SILICON,600V,500MA	14936	RGP10J-011
CR138	152-0586-00		SEMICONV DEVICE:SILICON,600V,500MA	14936	RGP10J-011
CR140	152-0586-00		SEMICONV DEVICE:SILICON,600V,500MA	14936	RGP10J-011
CR145	152-0574-00		SEMICONV DEVICE:SILICON,120V,0.15A	14433	WG1308
CR146	152-0574-00		SEMICONV DEVICE:SILICON,120V,0.15A	14433	WG1308
CR147	152-0574-00		SEMICONV DEVICE:SILICON,120V,0.15A	14433	WG1308
CR148	152-0574-00		SEMICONV DEVICE:SILICON,120V,0.15A	14433	WG1308
CR165	152-0333-00		SEMICONV DEVICE:SILICON,55V,200MA	07263	FDH-6012
CR166	152-0333-00		SEMICONV DEVICE:SILICON,55V,200MA	07263	FDH-6012
CR167	152-0333-00		SEMICONV DEVICE:SILICON,55V,200MA	07263	FDH-6012
CR168	152-0333-00		SEMICONV DEVICE:SILICON,55V,200MA	07263	FDH-6012
CR170	152-0107-03		SEMICONV DEVICE:SILICON,375V,400MA,SEL	01295	G727
CR190	152-0141-02		SEMICONV DEVICE:SILICON,30V,150MA	01295	1N4152R
CR196	152-0141-02		SEMICONV DEVICE:SILICON,30V,150MA	01295	1N4152R
CR235	152-0246-00		SEMICONV DEVICE:SW,SI,40V,200MA	03508	DE140
CR245	152-0141-02		SEMICONV DEVICE:SILICON,30V,150MA	01295	1N4152R
CR275	152-0333-00		SEMICONV DEVICE:SILICON,55V,200MA	07263	FDH-6012
CR280	153-0039-00		SEMICONV DVC SE: SIGNAL,PR	80009	153-0039-00
CR290	152-0141-02		SEMICONV DEVICE:SILICON,30V,150MA	01295	1N4152R
CR291	152-0141-02		SEMICONV DEVICE:SILICON,30V,150MA	01295	1N4152R
CR294	152-0066-00		SEMICONV DEVICE:SILICON,400V,750MA	14433	LG4016
CR320	152-0333-00		SEMICONV DEVICE:SILICON,55V,200MA	07263	FDH-6012
CR395	152-0333-00		SEMICONV DEVICE:SILICON,55V,200MA	07263	FDH-6012
CR397	152-0333-00		SEMICONV DEVICE:SILICON,55V,200MA	07263	FDH-6012
CR465	152-0141-02		SEMICONV DEVICE:SILICON,30V,150MA	01295	1N4152R
CR466	152-0141-02		SEMICONV DEVICE:SILICON,30V,150MA	01295	1N4152R
CR480	152-0141-02		SEMICONV DEVICE:SILICON,30V,150MA	01295	1N4152R
CR484	152-0141-02		SEMICONV DEVICE:SILICON,30V,150MA	01295	1N4152R
CR485	152-0141-02		SEMICONV DEVICE:SILICON,30V,150MA	01295	1N4152R
CR500	152-0141-02		SEMICONV DEVICE:SILICON,30V,150MA	01295	1N4152R
CR502	152-0141-02		SEMICONV DEVICE:SILICON,30V,150MA	01295	1N4152R

Replaceable Electrical Parts—PG 506(SN B040000-Up)

Ckt No.	Tektronix Part No.	Serial/Model No. Eff Dscnt	Name & Description	Mfr Code	Mfr Part Number
CR520	152-0141-02		SEMICONV DEVICE:SILICON,30V,150MA	01295	1N4152R
CR535	152-0141-02		SEMICONV DEVICE:SILICON,30V,150MA	01295	1N4152R
CR576	152-0141-02		SEMICONV DEVICE:SILICON,30V,150MA	01295	1N4152R
CR615	152-0141-02		SEMICONV DEVICE:SILICON,30V,150MA	01295	1N4152R
CR616	152-0141-02		SEMICONV DEVICE:SILICON,30V,150MA	01295	1N4152R
CR630	152-0141-02		SEMICONV DEVICE:SILICON,30V,150MA	01295	1N4152R
CR656	152-0141-02		SEMICONV DEVICE:SILICON,30V,150MA	01295	1N4152R
CR657	152-0141-02		SEMICONV DEVICE:SILICON,30V,150MA	01295	1N4152R
CR660	152-0141-02		SEMICONV DEVICE:SILICON,30V,150MA	01295	1N4152R
CR661	152-0141-02		SEMICONV DEVICE:SILICON,30V,150MA	01295	1N4152R
CR668	152-0141-02		SEMICONV DEVICE:SILICON,30V,150MA	01295	1N4152R
CR734	152-0066-00		SEMICONV DEVICE:SILICON,400V,750MA	14433	LG4016
CR755	152-0333-00		SEMICONV DEVICE:SILICON,55V,200MA	07263	FDH-6012
CR756	152-0536-00		SEMICONV DEVICE:SILICON,HOT CARRIER,4V	80009	152-0536-00
CR764	152-0333-00		SEMICONV DEVICE:SILICON,55V,200MA	07263	FDH-6012
CR766	152-0141-02		SEMICONV DEVICE:SILICON,30V,150MA	01295	1N4152R
CR767	152-0141-02		SEMICONV DEVICE:SILICON,30V,150MA	01295	1N4152R
CR800	152-0333-00		SEMICONV DEVICE:SILICON,55V,200MA	07263	FDH-6012
CR810	152-0233-00		SEMICONV DEVICE:SILICON,85V,100MA	07263	FDH1986
CR825	152-0141-02		SEMICONV DEVICE:SILICON,30V,150MA	01295	1N4152R
CR944	152-0536-00		SEMICONV DEVICE:SILICON,HOT CARRIER,4V	80009	152-0536-00
CR1004	152-0536-00		SEMICONV DEVICE:SILICON,HOT CARRIER,4V	80009	152-0536-00
CR1028	152-0141-02		SEMICONV DEVICE:SILICON,30V,150MA	01295	1N4152R
CR1047	152-0141-02		SEMICONV DEVICE:SILICON,30V,150MA	01295	1N4152R
CR1048	152-0141-02		SEMICONV DEVICE:SILICON,30V,150MA	01295	1N4152R
CR1062	152-0333-00		SEMICONV DEVICE:SILICON,55V,200MA	07263	FDH-6012
CR1067	152-0333-00		SEMICONV DEVICE:SILICON,55V,200MA	07263	FDH-6012
DS480	150-1001-01		LAMP,LED:RED,2V,100MA	50434	HLMP-3200
DS482	150-1001-01		LAMP,LED:RED,2V,100MA	50434	HLMP-3200
DS650	150-0048-00		LAMP,INCAND:5V,60MA	08806	683
DS700	150-1011-01		LAMP,LED,RDOUT:RED SINGLE DIGIT	07263	FND5169
DS702	150-1011-01		LAMP,LED,RDOUT:RED SINGLE DIGIT	07263	FND5169
DS704	150-0048-00		LAMP,INCAND:5V,60MA	08806	683
F30	159-0022-00		FUSE,CARTRIDGE:3AG,1A,250V,FAST-BLOW	71400	AGC 1
F65	159-0003-00		FUSE,CARTRIDGE:3AG,1.6A,250V,SLOW-BLOW	71400	MDX 1 6/10
J640	131-1315-01		CONN,RCPT,ELEC:BNC,FEMALE	24931	28JR 306-1
J820	131-1315-01		CONN,RCPT,ELEC:BNC,FEMALE	24931	28JR 306-1
J950	131-1727-00		CONNECTOR,RCPT,;BNC,FEMALE	24931	28JR262-1
J1010	131-1727-00		CONNECTOR,RCPT,;BNC,FEMALE	24931	28JR262-1
K2	148-0105-00		RELAY,ARMATURE:4 FORM C,5V,50 OHM COIL 3A	77342	T10-0010-2
K4	148-0105-00		RELAY,ARMATURE:4 FORM C,5V,50 OHM COIL 3A	77342	T10-0010-2
L35	108-0317-00		COIL,RF:FIXED,15UH	32159	71501M
L38	108-0574-00		COIL,RF:30UH	80009	108-0574-00
L65	108-0808-00		COIL,RF:FIXED,500UH	80009	108-0808-00
L135	108-0808-00		COIL,RF:FIXED,500UH	80009	108-0808-00
L145	108-0317-00		COIL,RF:FIXED,15UH	32159	71501M
L150	108-0317-00		COIL,RF:FIXED,15UH	32159	71501M
L165	108-0317-00		COIL,RF:FIXED,15UH	32159	71501M
L175	108-0317-00		COIL,RF:FIXED,15UH	32159	71501M
L582	108-0317-00		COIL,RF:FIXED,15UH	32159	71501M

Replaceable Electrical Parts—PG 506(SN B040000-Up)

Ckt No.	Tektronix Part No.	Serial/Model No. Eff Dscont	Name & Description	Mfr Code	Mfr Part Number
Q15	151-0302-00		TRANSISTOR:SILICON,NPN	07263	S038487
Q45	151-0515-01		SCR:SILICON	04713	SCR1256K
Q60	151-0301-00		TRANSISTOR:SILICON,PNP	27014	2N2907A
Q70	151-0301-00		TRANSISTOR:SILICON,PNP	27014	2N2907A
Q80	151-0473-00		TRANSISTOR:SILICON,NPN	03508	X44C388
Q85	151-0302-00		TRANSISTOR:SILICON,NPN	07263	S038487
Q90	151-0188-00		TRANSISTOR:SILICON,PNP	04713	SPS6868K
Q100	151-0188-00		TRANSISTOR:SILICON,PNP	04713	SPS6868K
Q120	151-0302-00		TRANSISTOR:SILICON,NPN	07263	S038487
Q125	151-0473-00		TRANSISTOR:SILICON,NPN	03508	X44C388
Q190	151-0347-00		TRANSISTOR:SILICON,NPN	56289	2N5551
Q245	151-0347-00		TRANSISTOR:SILICON,NPN	56289	2N5551
Q255	151-0190-00		TRANSISTOR:SILICON,NPN	07263	S032677
Q270	151-0347-00		TRANSISTOR:SILICON,NPN	56289	2N5551
Q280	151-0280-00		TRANSISTOR:SILICON,PNP	04713	SS8065
Q290	151-0280-00		TRANSISTOR:SILICON,PNP	04713	SS8065
Q320	151-0260-00		TRANSISTOR:SILICON,NPN	80009	151-0260-00
Q325	151-0462-00		TRANSISTOR:SILICON,PNP	04713	SJE491
Q326	151-0276-00		TRANSISTOR:SILICON,PNP	04713	2N5087
Q365	151-0440-00		TRANSISTOR:SILICON,PNP	03508	X41E603
Q410	151-0223-00		TRANSISTOR:SILICON,NPN	04713	SPS8026
Q415	151-0223-00		TRANSISTOR:SILICON,NPN	04713	SPS8026
Q435	151-0223-00		TRANSISTOR:SILICON,NPN	04713	SPS8026
Q440	151-0221-00		TRANSISTOR:SILICON,PNP	04713	SPS246
Q445	151-0223-00		TRANSISTOR:SILICON,NPN	04713	SPS8026
Q475	151-0223-00		TRANSISTOR:SILICON,NPN	04713	SPS8026
Q480	151-0221-00		TRANSISTOR:SILICON,PNP	04713	SPS246
Q490	151-0223-00		TRANSISTOR:SILICON,NPN	04713	SPS8026
Q535	151-0223-00		TRANSISTOR:SILICON,NPN	04713	SPS8026
Q560	151-0223-00		TRANSISTOR:SILICON,NPN	04713	SPS8026
Q565	151-0223-00		TRANSISTOR:SILICON,NPN	04713	SPS8026
Q575	151-0221-00		TRANSISTOR:SILICON,PNP	04713	SPS246
Q580	151-0221-00		TRANSISTOR:SILICON,PNP	04713	SPS246
Q585	151-0221-00		TRANSISTOR:SILICON,PNP	04713	SPS246
Q595	151-0223-00		TRANSISTOR:SILICON,NPN	04713	SPS8026
Q605	151-0223-00		TRANSISTOR:SILICON,NPN	04713	SPS8026
Q610	151-0221-00		TRANSISTOR:SILICON,PNP	04713	SPS246
Q715	151-0424-00		TRANSISTOR:SILICON,NPN	04713	SPS8246
Q725	151-0350-00		TRANSISTOR:SILICON,PNP	04713	SPS6700
Q730	151-0424-00		TRANSISTOR:SILICON,NPN	04713	SPS8246
Q736	151-0410-00		TRANSISTOR:SILICON,PNP	80009	151-0410-00
Q740	151-0350-00		TRANSISTOR:SILICON,PNP	04713	SPS6700
Q745	151-0446-00		TRANSISTOR:SILICON,NPN	80009	151-0446-00
Q758	151-1108-00		TRANSISTOR:FE,N-CHANNEL,SILICON	80009	151-1108-00
Q760	151-0406-00		TRANSISTOR:SILICON,PNP	04713	OBD
Q780	151-0410-00		TRANSISTOR:SILICON,PNP	80009	151-0410-00
Q782	151-0190-00		TRANSISTOR:SILICON,NPN	07263	S032677
Q784	151-0410-00		TRANSISTOR:SILICON,PNP	80009	151-0410-00
Q790	151-0350-00		TRANSISTOR:SILICON,PNP	04713	SPS6700
Q800	151-0350-00		TRANSISTOR:SILICON,PNP	04713	SPS6700
Q850	151-0190-00		TRANSISTOR:SILICON,NPN	07263	S032677
Q860	151-0225-00		TRANSISTOR:SILICON,NPN	07263	S39291
Q862	151-0225-00		TRANSISTOR:SILICON,NPN	07263	S39291
Q880	151-0434-00		TRANSISTOR:SILICON,PNP	04713	SS7144
Q890	151-0434-00		TRANSISTOR:SILICON,PNP	04713	SS7144

Replaceable Electrical Parts—PG 506(SN B040000-Up)

Ckt No.	Tektronix Part No.	Serial/Model No. Eff	Dscont	Name & Description	Mfr Code	Mfr Part Number
Q900	151-0441-00			TRANSISTOR:SILICON,NPN	04713	SRF501
Q910	151-0441-00			TRANSISTOR:SILICON,NPN	04713	SRF501
Q920	151-0271-00	B040000	B047129	TRANSISTOR:SILICON,PNP	04713	SPS8236
Q920	151-0271-03	B047130		TRANSISTOR:SILICON,PNP,SELECTED	04713	OBD
Q935	151-0271-00	B040000	B047129	TRANSISTOR:SILICON,PNP	04713	SPS8236
Q935	151-0271-03	B047130		TRANSISTOR:SILICON,PNP,SELECTED	04713	OBD
Q960	151-0271-00	B040000	B047129	TRANSISTOR:SILICON,PNP	04713	SPS8236
Q960	151-0271-03	B047130		TRANSISTOR:SILICON,PNP,SELECTED	04713	OBD
Q970	151-0271-00			TRANSISTOR:SILICON,PNP	04713	SPS8236
Q980	151-0447-00			TRANSISTOR:SILICON,NPN	04713	SRF502-1
Q995	151-0658-00			TRANSISTOR:SILICON,NPN	80009	151-0658-00
Q1020	151-0221-00			TRANSISTOR:SILICON,PNP	04713	SPS246
Q1030	151-0190-00			TRANSISTOR:SILICON,NPN	07263	S032677
Q1036	151-0424-00			TRANSISTOR:SILICON,NPN	04713	SPS8246
Q1045	151-0221-00			TRANSISTOR:SILICON,PNP	04713	SPS246
R10	315-0332-00			RES.,FXD,CMPSN:3.3K OHM,5%,0.25W	01121	CB3325
R15	315-0102-00			RES.,FXD,CMPSN:1K OHM,5%,0.25W	01121	CB1025
R20	315-0103-00			RES.,FXD,CMPSN:10K OHM,5%,0.25W	01121	CB1035
R21	315-0270-00			RES.,FXD,CMPSN:27 OHM,5%,0.25W	01121	CB2705
R22	308-0755-00			RES.,FXD,WW:0.75 OHM,5%,2W	75042	BWH-R7500J
R23	315-0270-00			RES.,FXD,CMPSN:27 OHM,5%,0.25W	01121	CB2705
R25	321-0290-00			RES.,FXD,FILM:10.2K OHM,1%,0.125W	91637	MFF1816G10201F
R27	321-0251-00			RES.,FXD,FILM:4.02K OHM,1%,0.125W	91637	MFF1816G40200F
R29	321-0154-00			RES.,FXD,FILM:392 OHM,1%,0.125W	91637	MFF1816G392R0F
R30	311-1223-00			RES.,VAR,NONWIR:TRMR,250 OHM,0.5W	02111	63M251T602
R31	321-0222-00			RES.,FXD,FILM:2K OHM,1%,0.125W	91637	MFF1816G20000F
R40	315-0431-00			RES.,FXD,CMPSN:430 OHM,5%,0.25W	01121	CB4315
R45	315-0470-00			RES.,FXD,CMPSN:47 OHM,5%,0.25W	01121	CB4705
R52	315-0102-00			RES.,FXD,CMPSN:1K OHM,5%,0.25W	01121	CB1025
R54	315-0202-00			RES.,FXD,CMPSN:2K OHM,5%,0.25W	01121	CB2025
R57	315-0103-00			RES.,FXD,CMPSN:10K OHM,5%,0.25W	01121	CB1035
R60	315-0131-00			RES.,FXD,CMPSN:130 OHM,5%,0.25W	01121	CB1315
R65	308-0677-00			RES.,FXD,WW:1 OHM,5%,2W	75042	BWH-1R000J
R70	315-0103-00			RES.,FXD,CMPSN:10K OHM,5%,0.25W	01121	CB1035
R72	315-0221-00			RES.,FXD,CMPSN:220 OHM,5%,0.25W	01121	CB2215
R75	301-0511-00			RES.,FXD,CMPSN:510 OHM,5%,0.50W	01121	EB5115
R80	315-0101-00			RES.,FXD,CMPSN:100 OHM,5%,0.25W	01121	CB1015
R82	315-0330-00			RES.,FXD,CMPSN:33 OHM,5%,0.25W	01121	CB3305
R85	315-0472-00			RES.,FXD,CMPSN:4.7K OHM,5%,0.25W	01121	CB4725
R86	315-0392-00			RES.,FXD,CMPSN:3.9K OHM,5%,0.25W	01121	CB3925
R90	315-0822-00			RES.,FXD,CMPSN:8.2K OHM,5%,0.25W	01121	CB8225
R94	315-0623-00			RES.,FXD,CMPSN:62K OHM,5%,0.25W	01121	CB6235
R96	315-0913-00			RES.,FXD,CMPSN:91K OHM,5%,0.25W	01121	CB9135
R98	315-0913-00			RES.,FXD,CMPSN:91K OHM,5%,0.25W	01121	CB9135
R100	315-0822-00			RES.,FXD,CMPSN:8.2K OHM,5%,0.25W	01121	CB8225
R104	315-0623-00			RES.,FXD,CMPSN:62K OHM,5%,0.25W	01121	CB6235
R105	315-0392-00			RES.,FXD,CMPSN:3.9K OHM,5%,0.25W	01121	CB3925
R108	315-0472-00			RES.,FXD,CMPSN:4.7K OHM,5%,0.25W	01121	CB4725
R120	315-0330-00			RES.,FXD,CMPSN:33 OHM,5%,0.25W	01121	CB3305
R122	315-0101-00			RES.,FXD,CMPSN:100 OHM,5%,0.25W	01121	CB1015
R135	315-0124-00			RES.,FXD,CMPSN:120K OHM,5%,0.25W	01121	CB1245
R154	315-0683-00			RES.,FXD,CMPSN:68K OHM,5%,0.25W	01121	CB6835
R170	315-0103-00			RES.,FXD,CMPSN:10K OHM,5%,0.25W	01121	CB1035
R190	305-0512-00			RES.,FXD,CMPSN:5.1K OHM,5%,2W	01121	HB5125

Replaceable Electrical Parts—PG 506(SN B040000-Up)

Ckt No.	Tektronix Part No.	Serial/Model No. Eff	Dscont	Name & Description	Mfr Code	Mfr Part Number
R194	315-0104-00			RES.,FXD,CMPSN:100K OHM,5%,0.25W	01121	CB1045
R196	315-0203-00			RES.,FXD,CMPSN:20K OHM,5%,0.25W	01121	CB2035
R200	321-0289-07			RES.,FXD,FILM:10K OHM,0.1%,0.125W	91637	MFF1816C10001B
R205	311-1340-00			RES.,VAR,NONWIR:1K OHM,10%,0.50W	02111	43P102T672
R207	321-0289-07			RES.,FXD,FILM:10K OHM,0.1%,0.125W	91637	MFF1816C10001B
R210	323-1200-07			RES.,FXD,FILM:1.20K OHM,0.1%,0.50W	91637	MFF1226C12000B
R212	321-0264-00			RES.,FXD,FILM:5.49K OHM,1%,0.125W	91637	MFF1816G54900F
R215	321-0279-00			RES.,FXD,FILM:7.87K OHM,1%,0.125W	91637	MFF1816G78700F
R220	321-0213-00	B040000	B046759	RES.,FXD,FILM:1.62K OHM,1%,0.125W	91637	MFF1816G16200F
R220	321-0216-00	B046760		RES.,FXD,FILM:1.74K OHM,1%,0.125W	91637	MFF1816G17400F
R225	311-1586-00			RES.,VAR,NONWIR:PNL,2 X 20K OHM,0.5W	01121	12M271
R255	-----			(PART OF S225)		
R227	321-1649-07			RES.,FXD,FILM:8.38K OHM,0.1%,0.125W	91637	MFF1816C83800B
R230	321-0213-00	B040000	B046759	RES.,FXD,FILM:1.62K OHM,1%,0.125W	91637	MFF1816G16200F
R230	321-0216-00	B046760		RES.,FXD,FILM:1.74K OHM,1%,0.125W	91637	MFF1816G17400F
R234	323-0381-07			RES.,FXD,FILM:90.9K OHM,0.1%,0.50W	91637	MFF1226C90901B
R237	321-1650-07			RES.,FXD,FILM:8.99K OHM,0.1%,0.125W	91637	MFF1816C89900B
R238	315-0391-00			RES.,FXD,CMPSN:390 OHM,5%,0.25W	01121	CB3915
R245	315-0102-00			RES.,FXD,CMPSN:1K OHM,5%,0.25W	01121	CB1025
R247	301-0513-00			RES.,FXD,CMPSN:51K OHM,5%,0.50W	01121	EB5135
R250	315-0102-00			RES.,FXD,CMPSN:1K OHM,5%,0.25W	01121	CB1025
R255	315-0221-00			RES.,FXD,CMPSN:220 OHM,5%,0.25W	01121	CB2215
R256	315-0203-00			RES.,FXD,CMPSN:20K OHM,5%,0.25W	01121	CB2035
R257	315-0103-00			RES.,FXD,CMPSN:10K OHM,5%,0.25W	01121	CB1035
R258	315-0102-00			RES.,FXD,CMPSN:1K OHM,5%,0.25W	01121	CB1025
R260	315-0241-00			RES.,FXD,CMPSN:240 OHM,5%,0.25W	01121	CB2415
R265	315-0241-00			RES.,FXD,CMPSN:240 OHM,5%,0.25W	01121	CB2415
R267	315-0202-00			RES.,FXD,CMPSN:2K OHM,5%,0.25W	01121	CB2025
R275	325-0193-00			RES SET,MATCHED:(4) RES R FROM 0-60 DEG C	75042	OBD
R276	-----			(PART OF R275)		
R277	-----			(PART OF R275)		
R278	-----			(PART OF R275)		
R280	321-0154-00			RES.,FXD,FILM:392 OHM,1%,0.125W	91637	MFF1816G392R0F
R287	303-0223-00			RES.,FXD,CMPSN:22K OHM,5%,1W	01121	GB2235
R290	315-0130-00			RES.,FXD,CMPSN:13 OHM,5%,0.25W	01121	CB1305
R295	315-0203-00			RES.,FXD,CMPSN:20K OHM,5%,0.25W	01121	CB2035
R300	308-0787-00			RES SET,MATCHED:4,495 OHM,0.1%,3W	91637	SPR993
R302	-----			(PART OF R300)		
R304	-----			(PART OF R300)		
R306	-----			(PART OF R300)		
R308	-----			(PART OF R300)		
R310	-----			(PART OF R300)		
R312	-----			(PART OF R300)		
R314	-----			(PART OF R300)		
R315	321-0291-00			RES.,FXD,FILM:10.5K OHM,1%,0.125W	91637	MFF1816G10501F
R317	315-0510-00			RES.,FXD,CMPSN:51 OHM,5%,0.25W	01121	CB5105
R330	315-0102-00			RES.,FXD,CMPSN:1K OHM,5%,0.25W	01121	CB1025
R332	321-0189-00			RES.,FXD,FILM:909 OHM,1%,0.125W	91637	MFF1816G909R0F
R338	321-0296-07			RES.,FXD,FILM:11.8K OHM,0.1%,0.125W	91637	MFF1816C11801B
R340	311-1221-00			RES.,VAR,NONWIR:50 OHM,20%,0.50W	32997	3386F-T04-500
R342	321-0188-09			RES.,FXD,FILM:887 OHM,1%,0.125W	91637	MFF1816C887R0F
R350	308-0786-00			RES SET MATCHED:7,15 OHM,0.1%,0.5W	91637	SPR993-1
R352	-----			(PART OF R350)		
R354	-----			(PART OF R350)		
R356	308-0786-00			RES SET MATCHED:7,15 OHM,0.1%,0.5W	91637	SPR993-1

Replaceable Electrical Parts—PG 506(SN B040000-Up)

Ckt No.	Tektronix Part No.	Serial/Model No. Eff Dscont	Name & Description	Mfr Code	Mfr Part Number
R358	-----		(PART OF R350)		
R360	-----		(PART OF R350)		
R362	-----		(PART OF R350)		
R375	315-0102-00		RES.,FXD,CMPSN:1K OHM,5%,0.25W	01121	CB1025
R377	321-0230-00		RES.,FXD,FILM:2.43K OHM,1%,0.125W	91637	MFF1816G24300F
R380	315-0242-00		RES.,FXD,CMPSN:2.4K OHM,5%,0.25W	01121	CB2425
R382	315-0431-00		RES.,FXD,CMPSN:430 OHM,5%,0.25W	01121	CB4315
R400	315-0242-00		RES.,FXD,CMPSN:2.4K OHM,5%,0.25W	01121	CB2425
R405	315-0242-00		RES.,FXD,CMPSN:2.4K OHM,5%,0.25W	01121	CB2425
R407	315-0132-00		RES.,FXD,CMPSN:1.3K OHM,5%,0.25W	01121	CB1325
R410	315-0163-00		RES.,FXD,CMPSN:16K OHM,5%,0.25W	01121	CB1635
R415	311-1225-00		RES.,VAR,NONWIR:1K OHM,20%,0.50W	32997	3386F-T04-102
R417	321-0287-00		RES.,FXD,FILM:9.53K OHM,1%,0.125W	91637	MFF1816G95300F
R420	321-0260-00		RES.,FXD,FILM:4.99K OHM,1%,0.125W	91637	MFF1816G49900F
R423	321-0229-00		RES.,FXD,FILM:2.37K OHM,1%,0.125W	91637	MFF1816G23700F
R425	311-1224-00		RES.,VAR,NONWIR:500 OHM,20%,0.50W	32997	3386F-T04-501
R427	321-0227-09		RES.,FXD,FILM:2.26K OHM,1%,0.125W	91637	MFF1816C22600F
R430	321-0261-00		RES.,FXD,FILM:5.11K OHM,1%,0.125W	91637	MFF1816G51100F
R435	315-0102-00		RES.,FXD,CMPSN:1K OHM,5%,0.25W	01121	CB1025
R440	315-0102-00		RES.,FXD,CMPSN:1K OHM,5%,0.25W	01121	CB1025
R445	315-0272-00		RES.,FXD,CMPSN:2.7K OHM,5%,0.25W	01121	CB2725
R447	315-0562-00		RES.,FXD,CMPSN:5.6K OHM,5%,0.25W	01121	CB5625
R450	311-1224-00		RES.,VAR,NONWIR:500 OHM,20%,0.50W	32997	3386F-T04-501
R452	323-0796-07		RES.,FXD,FILM:11.34K OHM,0.1%,0.50W	91637	CMF1418C11341B
R454	323-0796-07		RES.,FXD,FILM:11.34K OHM,0.1%,0.50W	91637	CMF1418C11341B
R460	321-0223-00		RES.,FXD,FILM:2.05K OHM,1%,0.125W	91637	MFF1816G20500F
R465	315-0332-00		RES.,FXD,CMPSN:3.3K OHM,5%,0.25W	01121	CB3325
R470	315-0242-00		RES.,FXD,CMPSN:2.4K OHM,5%,0.25W	01121	CB2425
R475	315-0332-00		RES.,FXD,CMPSN:3.3K OHM,5%,0.25W	01121	CB3325
R477	315-0181-00		RES.,FXD,CMPSN:180 OHM,5%,0.25W	01121	CB1815
R480	315-0102-00		RES.,FXD,CMPSN:1K OHM,5%,0.25W	01121	CB1025
R482	317-0102-00		RES.,FXD,CMPSN:1K OHM,5%,0.125W	01121	BB1025
R484	315-0392-00		RES.,FXD,CMPSN:3.9K OHM,5%,0.25W	01121	CB3925
R486	315-0202-00		RES.,FXD,CMPSN:2K OHM,5%,0.25W	01121	CB2025
R490	315-0102-00		RES.,FXD,CMPSN:1K OHM,5%,0.25W	01121	CB1025
R495	315-0431-00		RES.,FXD,CMPSN:430 OHM,5%,0.25W	01121	CB4315
R500	315-0133-00		RES.,FXD,CMPSN:13K OHM,5%,0.25W	01121	CB1335
R502	315-0822-00		RES.,FXD,CMPSN:8.2K OHM,5%,0.25W	01121	CB8225
R506	315-0133-00		RES.,FXD,CMPSN:13K OHM,5%,0.25W	01121	CB1335
R508	315-0822-00		RES.,FXD,CMPSN:8.2K OHM,5%,0.25W	01121	CB8225
R510	315-0273-00		RES.,FXD,CMPSN:27K OHM,5%,0.25W	01121	CB2735
R514	315-0202-00		RES.,FXD,CMPSN:2K OHM,5%,0.25W	01121	CB2025
R516	315-0272-00		RES.,FXD,CMPSN:2.7K OHM,5%,0.25W	01121	CB2725
R520	315-0102-00		RES.,FXD,CMPSN:1K OHM,5%,0.25W	01121	CB1025
R524	315-0391-00		RES.,FXD,CMPSN:390 OHM,5%,0.25W	01121	CB3915
R530	315-0472-00		RES.,FXD,CMPSN:4.7K OHM,5%,0.25W	01121	CB4725
R532	315-0392-00		RES.,FXD,CMPSN:3.9K OHM,5%,0.25W	01121	CB3925
R535	315-0391-00		RES.,FXD,CMPSN:390 OHM,5%,0.25W	01121	CB3915
R560	315-0472-00		RES.,FXD,CMPSN:4.7K OHM,5%,0.25W	01121	CB4725
R563	315-0472-00		RES.,FXD,CMPSN:4.7K OHM,5%,0.25W	01121	CB4725
R565	315-0102-00		RES.,FXD,CMPSN:1K OHM,5%,0.25W	01121	CB1025
R575	315-0242-00		RES.,FXD,CMPSN:2.4K OHM,5%,0.25W	01121	CB2425
R576	315-0132-00		RES.,FXD,CMPSN:1.3K OHM,5%,0.25W	01121	CB1325
R578	315-0511-00		RES.,FXD,CMPSN:510 OHM,5%,0.25W	01121	CB5115
R582	315-0241-00		RES.,FXD,CMPSN:240 OHM,5%,0.25W	01121	CB2415

Replaceable Electrical Parts—PG 506(SN B040000-Up)

Ckt No.	Tektronix Part No.	Serial/Model No. Eff Dscont	Name & Description	Mfr Code	Mfr Part Number
R585	315-0100-00		RES.,FXD,CMPSN:10 OHM,5%,0.25W	01121	CB1005
R587	311-1223-00		RES.,VAR,NONWIR:TRMR,250 OHM,0.5W	02111	63M251T602
R590	311-1747-00		RES.,VAR,NONWIR:PNL,10K OHM,1W	01121	17M360
R593	315-0471-00		RES.,FXD,CMPSN:470 OHM,5%,0.25W	01121	CB4715
R595	315-0102-00		RES.,FXD,CMPSN:1K OHM,5%,0.25W	01121	CB1025
R597	315-0102-00		RES.,FXD,CMPSN:1K OHM,5%,0.25W	01121	CB1025
R600	315-0102-00		RES.,FXD,CMPSN:1K OHM,5%,0.25W	01121	CB1025
R602	315-0102-00		RES.,FXD,CMPSN:1K OHM,5%,0.25W	01121	CB1025
R605	315-0102-00		RES.,FXD,CMPSN:1K OHM,5%,0.25W	01121	CB1025
R606	315-0271-00		RES.,FXD,CMPSN:270 OHM,5%,0.25W	01121	CB2715
R615	315-0103-00		RES.,FXD,CMPSN:10K OHM,5%,0.25W	01121	CB1035
R618	315-0511-00		RES.,FXD,CMPSN:510 OHM,5%,0.25W	01121	CB5115
R620	315-0273-00		RES.,FXD,CMPSN:27K OHM,5%,0.25W	01121	CB2735
R625	315-0100-00		RES.,FXD,CMPSN:10 OHM,5%,0.25W	01121	CB1005
R627	301-0131-00		RES.,FXD,CMPSN:130 OHM,5%,0.50W	01121	EB1315
R630	315-0100-00		RES.,FXD,CMPSN:10 OHM,5%,0.25W	01121	CB1005
R635	315-0102-00		RES.,FXD,CMPSN:1K OHM,5%,0.25W	01121	CB1025
R650	315-0100-00		RES.,FXD,CMPSN:10 OHM,5%,0.25W	01121	CB1005
R654	315-0511-00		RES.,FXD,CMPSN:510 OHM,5%,0.25W	01121	CB5115
R656	315-0103-00		RES.,FXD,CMPSN:10K OHM,5%,0.25W	01121	CB1035
R660	315-0103-00		RES.,FXD,CMPSN:10K OHM,5%,0.25W	01121	CB1035
R680	315-0681-00		RES.,FXD,CMPSN:680 OHM,5%,0.25W	01121	CB6815
R681	315-0681-00		RES.,FXD,CMPSN:680 OHM,5%,0.25W	01121	CB6815
R682	315-0681-00		RES.,FXD,CMPSN:680 OHM,5%,0.25W	01121	CB6815
R683	315-0681-00		RES.,FXD,CMPSN:680 OHM,5%,0.25W	01121	CB6815
R684	315-0681-00		RES.,FXD,CMPSN:680 OHM,5%,0.25W	01121	CB6815
R685	315-0681-00		RES.,FXD,CMPSN:680 OHM,5%,0.25W	01121	CB6815
R686	315-0681-00		RES.,FXD,CMPSN:680 OHM,5%,0.25W	01121	CB6815
R690	315-0681-00		RES.,FXD,CMPSN:680 OHM,5%,0.25W	01121	CB6815
R691	315-0681-00		RES.,FXD,CMPSN:680 OHM,5%,0.25W	01121	CB6815
R692	315-0681-00		RES.,FXD,CMPSN:680 OHM,5%,0.25W	01121	CB6815
R693	315-0681-00		RES.,FXD,CMPSN:680 OHM,5%,0.25W	01121	CB6815
R694	315-0681-00		RES.,FXD,CMPSN:680 OHM,5%,0.25W	01121	CB6815
R695	315-0681-00		RES.,FXD,CMPSN:680 OHM,5%,0.25W	01121	CB6815
R696	315-0681-00		RES.,FXD,CMPSN:680 OHM,5%,0.25W	01121	CB6815
R700	315-0681-00		RES.,FXD,CMPSN:680 OHM,5%,0.25W	01121	CB6815
R705	315-0200-00		RES.,FXD,CMPSN:20 OHM,5%,0.25W	01121	CB2005
R715	315-0102-00		RES.,FXD,CMPSN:1K OHM,5%,0.25W	01121	CB1025
R716	315-0102-00		RES.,FXD,CMPSN:1K OHM,5%,0.25W	01121	CB1025
R718	315-0621-00		RES.,FXD,CMPSN:620 OHM,5%,0.25W	01121	CB6215
R724	315-0152-00		RES.,FXD,CMPSN:1.5K OHM,5%,0.25W	01121	CB1525
R730	315-0392-00		RES.,FXD,CMPSN:3.9K OHM,5%,0.25W	01121	CB3925
R736	301-0223-00		RES.,FXD,CMPSN:22K OHM,5%,0.50W	01121	EB2235
R738	315-0330-00		RES.,FXD,CMPSN:33 OHM,5%,0.25W	01121	CB3305
R740	315-0112-00		RES.,FXD,CMPSN:1.1K OHM,5%,0.25W	01121	CB1125
R745	301-0240-00		RES.,FXD,CMPSN:24 OHM,5%,0.50W	01121	EB2405
R746	303-0682-00		RES.,FXD,CMPSN:6.8K OHM,5%,1W	01121	GB6825
R752	315-0390-00		RES.,FXD,CMPSN:39 OHM,5%,0.25W	01121	CB3905
R757	315-0221-00		RES.,FXD,CMPSN:220 OHM,5%,0.25W	01121	CB2215
R757	-----		(NOMINAL VALUE,SELECTED)		
R760	315-0271-00		RES.,FXD,CMPSN:270 OHM,5%,0.25W	01121	CB2715
R762	315-0222-00		RES.,FXD,CMPSN:2.2K OHM,5%,0.25W	01121	CB2225
R764	315-0222-00		RES.,FXD,CMPSN:2.2K OHM,5%,0.25W	01121	CB2225
R780	315-0182-00		RES.,FXD,CMPSN:1.8K OHM,5%,0.25W	01121	CB1825
R782	315-0122-00		RES.,FXD,CMPSN:1.2K OHM,5%,0.25W	01121	CB1225
R784	315-0561-00		RES.,FXD,CMPSN:560 OHM,5%,0.25W	01121	CB5615

Replaceable Electrical Parts—PG 506(SN B040000-Up)

Ckt No.	Tektronix Part No.	Serial/Model No. Eff	Dscont	Name & Description	Mfr Code	Mfr Part Number
R785	311-1473-00			RES.,VAR, NONWIR:PNL,2 X 5K OHM,0.5W	01121	11M079
R787	315-0272-00			RES.,FXD,CMPSN:2.7K OHM,5%,0.25W	01121	CB2725
R790	311-1562-00			RES.,VAR, NONWIR:2K OHM,20%,0.50W	73138	91-84-0
R792	315-0112-00			RES.,FXD,CMPSN:1.1K OHM,5%,0.25W	01121	CB1125
R800	315-0102-00			RES.,FXD,CMPSN:1K OHM,5%,0.25W	01121	CB1025
R805	308-0392-00			RES.,FXD,WW:600 OHM,2%,14W	56289	459EX600R0J
R825	315-0273-00			RES.,FXD,CMPSN:27K OHM,5%,0.25W	01121	CB2735
R827	315-0104-00			RES.,FXD,CMPSN:100K OHM,5%,0.25W	01121	CB1045
R830	321-0256-00			RES.,FXD,FILM:4.53K OHM,1%,0.125W	91637	MFF1816G45300F
R832	321-0385-00			RES.,FXD,FILM:100K OHM,1%,0.125W	91637	MFF1816G10002F
R835	321-0256-00			RES.,FXD,FILM:4.53K OHM,1%,0.125W	91637	MFF1816G45300F
R837	321-0385-00			RES.,FXD,FILM:100K OHM,1%,0.125W	91637	MFF1816G10002F
R840	315-0104-00			RES.,FXD,CMPSN:100K OHM,5%,0.25W	01121	CB1045
R842	315-0102-00			RES.,FXD,CMPSN:1K OHM,5%,0.25W	01121	CB1025
R850	322-0164-00			RES.,FXD,FILM:499 OHM,1%,0.25W	75042	CEBT0-4990F
R854	321-0251-00			RES.,FXD,FILM:4.02K OHM,1%,0.125W	91637	MFF1816G40200F
R855	321-0239-00			RES.,FXD,FILM:3.01K OHM,1%,0.125W	91637	MFF1816G30100F
R857	315-0511-00			RES.,FXD,CMPSN:510 OHM,5%,0.25W	01121	CB5115
R860	307-0106-00			RES.,FXD,CMPSN:4.7 OHM,5%,0.25W	01121	CB47G5
R862	307-0106-00			RES.,FXD,CMPSN:4.7 OHM,5%,0.25W	01121	CB47G5
R865	315-0822-00			RES.,FXD,CMPSN:8.2K OHM,5%,0.25W	01121	CB8225
R866	315-0101-00			RES.,FXD,CMPSN:100 OHM,5%,0.25W	01121	CB1015
R870	315-0390-00			RES.,FXD,CMPSN:39 OHM,5%,0.25W	01121	CB3905
R871	315-0360-00			RES.,FXD,CMPSN:36 OHM,5%,0.25W	01121	CB3605
R874	322-0164-00			RES.,FXD,FILM:499 OHM,1%,0.25W	75042	CEBT0-4990F
R876	315-0750-00			RES.,FXD,CMPSN:75 OHM,5%,0.25W	01121	CB7505
R880	315-0243-00			RES.,FXD,CMPSN:24K OHM,5%,0.25W	01121	CB2435
R882	321-0069-00			RES.,FXD,FILM:51.1 OHM,1%,0.125W	91637	MFF1816G51R10F
R884	315-0911-00			RES.,FXD,CMPSN:910 OHM,5%,0.25W	01121	CB9115
R886	317-0220-00			RES.,FXD,CMPSN:22 OHM,5%,0.125W	01121	BB2205
R890	315-0911-00			RES.,FXD,CMPSN:910 OHM,5%,0.25W	01121	CB9115
R892	321-0069-00			RES.,FXD,FILM:51.1 OHM,1%,0.125W	91637	MFF1816G51R10F
R900	317-0220-00			RES.,FXD,CMPSN:22 OHM,5%,0.125W	01121	BB2205
R902	315-0162-00			RES.,FXD,CMPSN:1.6K OHM,5%,0.25W	01121	CB1625
R904	315-0162-00			RES.,FXD,CMPSN:1.6K OHM,5%,0.25W	01121	CB1625
R906	317-0100-00			RES.,FXD,CMPSN:10 OHM,5%,0.125W	01121	BB1005
R910	317-0220-00			RES.,FXD,CMPSN:22 OHM,5%,0.125W	01121	BB2205
R914	315-0101-00			RES.,FXD,CMPSN:100 OHM,5%,0.25W	01121	CB1015
R916	321-0150-00			RES.,FXD,FILM:357 OHM,1%,0.125W	91637	MFF1816G357R0F
R918	315-0151-00			RES.,FXD,CMPSN:150 OHM,5%,0.25W	01121	CB1515
R920	315-0100-00			RES.,FXD,CMPSN:10 OHM,5%,0.25W	01121	CB1005
R924	307-0106-00			RES.,FXD,CMPSN:4.7 OHM,5%,0.25W	01121	CB47G5
R928	323-0097-00			RES.,FXD,FILM:100 OHM,1%,0.50W	75042	CECT0-1000F
R930	323-0099-00			RES.,FXD,FILM:105 OHM,1%,0.50W	75042	CECT0-1050F
R935	317-0471-00			RES.,FXD,CMPSN:470 OHM,5%,0.125W	01121	BB4715
R937	315-0330-00			RES.,FXD,CMPSN:33 OHM,5%,0.25W	01121	CB3305
R937	-----			(NOMINAL VALUE,SELECTED)		
R938	315-0431-00			RES.,FXD,CMPSN:430 OHM,5%,0.25W	01121	CB4315
R940	317-0121-00			RES.,FXD,CMPSN:120 OHM,5%,0.125W	01121	BB1215
R940	-----			(NOMINAL VALUE,SELECTED)		
R944	317-0180-00			RES.,FXD,CMPSN:18 OHM,5%,0.125W	01121	BB1805
R950	307-0086-00			RES.,FXD,FILM:50 OHM,1%	03888	62D350-50R0F
R960	317-0220-00			RES.,FXD,CMPSN:22 OHM,5%,0.125W	01121	BB2205
R962	315-0162-00			RES.,FXD,CMPSN:1.6K OHM,5%,0.25W	01121	CB1625

Replaceable Electrical Parts—PG 506(SN B040000-Up)

Ckt No.	Tektronix Part No.	Serial/Model No. Eff	Dscont	Name & Description	Mfr Code	Mfr Part Number
R964	315-0162-00			RES.,FXD,CMPSN:1.6K OHM,5%,0.25W	01121	CB1625
R966	317-0100-00			RES.,FXD,CMPSN:10 OHM,5%,0.125W	01121	BB1005
R970	317-0220-00			RES.,FXD,CMPSN:22 OHM,5%,0.125W	01121	BB2205
R974	315-0101-00			RES.,FXD,CMPSN:100 OHM,5%,0.25W	01121	CB1015
R976	323-0150-00			RES.,FXD,FILM:357 OHM,1%,0.50W	91637	MFF1226G357R0F
R978	315-0151-00			RES.,FXD,CMPSN:150 OHM,5%,0.25W	01121	CB1515
R980	315-0100-00			RES.,FXD,CMPSN:10 OHM,5%,0.25W	01121	CB1005
R984	307-0106-00			RES.,FXD,CMPSN:4.7 OHM,5%,0.25W	01121	CB47G5
R988	323-0099-00			RES.,FXD,FILM:105 OHM,1%,0.50W	75042	CECT0-1050F
R990	323-0097-00			RES.,FXD,FILM:100 OHM,1%,0.50W	75042	CECT0-1000F
R995	317-0471-00			RES.,FXD,CMPSN:470 OHM,5%,0.125W	01121	BB4715
R997	315-0330-00			RES.,FXD,CMPSN:33 OHM,5%,0.25W	01121	CB3305
R998	315-0431-00			RES.,FXD,CMPSN:430 OHM,5%,0.25W	01121	CB4315
R1000	317-0121-00			RES.,FXD,CMPSN:120 OHM,5%,0.125W	01121	BB1215
R1000	-----			(NOMINAL VALUE,SELECTED)		
R1004	317-0180-00			RES.,FXD,CMPSN:18 OHM,5%,0.125W	01121	BB1805
R1010	307-0086-00			RES.,FXD,FILM:50 OHM,1%	03888	62D350-50R0F
R1020	315-0102-00			RES.,FXD,CMPSN:1K OHM,5%,0.25W	01121	CB1025
R1021	315-0123-00			RES.,FXD,CMPSN:12K OHM,5%,0.25W	01121	CB1235
R1025	311-1562-00			RES.,VAR,NONWIR:2K OHM,20%,0.50W	73138	91-84-0
R1026	315-0332-00			RES.,FXD,CMPSN:3.3K OHM,5%,0.25W	01121	CB3325
R1028	315-0133-00			RES.,FXD,CMPSN:13K OHM,5%,0.25W	01121	CB1335
R1030	315-0332-00			RES.,FXD,CMPSN:3.3K OHM,5%,0.25W	01121	CB3325
R1034	315-0273-00			RES.,FXD,CMPSN:27K OHM,5%,0.25W	01121	CB2735
R1036	315-0100-00			RES.,FXD,CMPSN:10 OHM,5%,0.25W	01121	CB1005
R1040	315-0270-00	B040000	B058179	RES.,FXD,CMPSN:27 OHM,5%,0.25W	01121	CB2705
R1040	315-0240-00	B058180		RES.,FXD,CMPSN:24 OHM,5%,0.25W	01121	CB2405
R1045	315-0100-00			RES.,FXD,CMPSN:10 OHM,5%,0.25W	01121	CB1005
R1047	315-0272-00			RES.,FXD,CMPSN:2.7K OHM,5%,0.25W	01121	CB2725
S180	263-1098-03			SW CAM ACTR AS:MODE/AMPLITUDE	80009	263-1098-03
S225	-----			(PART OF R225)		
S610	263-1101-00			SW CAM ACTR AS:PERIOD	80009	263-1101-00
S660	260-0723-00			SWITCH,SLIDE:DPDT,0.5A,125VAC	79727	GF126-0028
T75	120-0951-00			TRANSFORMER,RF:BALUN	80009	120-0951-00
T130	120-0953-00			TRANSFORMER,RF:POT CORE,BIFILAR	80009	120-0953-00
T520	120-0952-00			TRANSFORMER,RF:2 WINDINGS	80009	120-0952-00
T532	120-0952-00			TRANSFORMER,RF:2 WINDINGS	80009	120-0952-00
U20	156-0071-00			MICROCIRCUIT,LI:VOLTAGE REGULATOR	04713	MC1723CL
U50	156-0067-00			MICROCIRCUIT,LI:OPERATIONAL AMPLIFIER	01295	MICROA741CP
U200	156-0067-00			MICROCIRCUIT,LI:OPERATIONAL AMPLIFIER	01295	MICROA741CP
U240	156-0067-00			MICROCIRCUIT,LI:OPERATIONAL AMPLIFIER	01295	MICROA741CP
U255	156-0399-00			MICROCIRCUIT,DI:OPTOELECTRONIC ISOLATOR	04713	4N27
U330	156-0067-00	B040000	B046759	MICROCIRCUIT,LI:OPERATIONAL AMPLIFIER	01295	MICROA741CP
U330	156-0067-11	B046760		MICROCIRCUIT,LI:OPERATIONAL AMPLIFIER	02735	CA741CE
U375	156-0067-00	B040000	B046759	MICROCIRCUIT,LI:OPERATIONAL AMPLIFIER	01295	MICROA741CP
U375	156-0067-11	B046760		MICROCIRCUIT,LI:OPERATIONAL AMPLIFIER	02735	CA741CE
U400	156-0113-03			MICROCIRCUIT,DI:QUAD 2 INP NAND GATE,SCRN,	01295	SN74L00NP3
U430	156-0067-00			MICROCIRCUIT,LI:OPERATIONAL AMPLIFIER	01295	MICROA741CP
U460	156-0067-00			MICROCIRCUIT,LI:OPERATIONAL AMPLIFIER	01295	MICROA741CP
U470	156-0134-00			MICROCIRCUIT,LI:DIFFERENTIAL COMPARATOR	01295	TL710CP
U480	156-0399-00			MICROCIRCUIT,DI:OPTOELECTRONIC ISOLATOR	04713	4N27
U610	156-0039-02			MICROCIRCUIT,DI:DUAL J-K MA-SLAVE FF,SCRN	01295	SN7473(NP3 OR JP

Replaceable Electrical Parts—PG 506(SN B040000-Up)

Ckt No.	Tektronix Part No.	Serial/Model No. Eff Dscont	Name & Description	Mfr Code	Mfr Part Number
U615	156-0186-02		MICROCIRCUIT,DI:QUAD 2-INP NAND GATE,SCRN	01295	SN7403(NP3 OR JP
U665	156-0079-02		MICROCIRCUIT,DI:DECADE COUNTER,SCREENED	01295	SN7490A(NP3 OR J
U666	156-0079-02		MICROCIRCUIT,DI:DECADE COUNTER,SCREENED	01295	SN7490A(NP3 OR J
U667	156-0079-02		MICROCIRCUIT,DI:DECADE COUNTER,SCREENED	01295	SN7490A(NP3 OR J
U668	156-0079-02		MICROCIRCUIT,DI:DECADE COUNTER,SCREENED	01295	SN7490A(NP3 OR J
U670	156-0040-02		MICROCIRCUIT,DI:QUAD LATCH,SCREENED	01295	SN7475(NP3 OR JP
U671	156-0040-02		MICROCIRCUIT,DI:QUAD LATCH,SCREENED	01295	SN7475(NP3 OR JP
U673	156-0379-00		MICROCIRCUIT,DI:BCD TO 7-SEGMENT DCDR/DRVR	80009	156-0379-00
U675	156-0379-00		MICROCIRCUIT,DI:BCD TO 7-SEGMENT DCDR/DRVR	80009	156-0379-00
U840	156-0067-00		MICROCIRCUIT,LI:OPERATIONAL AMPLIFIER	01295	MICROA741CP
VR10	152-0243-00		SEMICONV DEVICE:ZENER,0.4W,15V,5%	14552	TD3810983
VR30	152-0168-00		SEMICONV DEVICE:ZENER,0.4W,12V,5%	04713	SZG35009K4
VR42	152-0662-00		SEMICONV DEVICE:ZENER,0.4W,5V,1%	04713	SZG195
VR45	152-0175-00		SEMICONV DEVICE:ZENER,0.4W,5.6V,5%	04713	SZG35008
VR170	152-0195-00		SEMICONV DEVICE:ZENER,0.4W,5.1V,5%	04713	SZ11755
VR210	152-0174-00		SEMICONV DEVICE:ZENER,0.5W,9V,5%	80009	152-0174-00
VR280	152-0195-00		SEMICONV DEVICE:ZENER,0.4W,5.1V,5%	04713	SZ11755
VR395	152-0055-00		SEMICONV DEVICE:ZENER,0.4W,11V,5%	04713	SZG35009K1
VR430	152-0195-00		SEMICONV DEVICE:ZENER,0.4W,5.1V,5%	04713	SZ11755
VR470	152-0395-00		SEMICONV DEVICE:ZENER,0.4W,4.3V,5%	14552	TD332317
VR790	152-0195-00		SEMICONV DEVICE:ZENER,0.4W,5.1V,5%	04713	SZ11755
VR792	152-0667-00		SEMICONV DEVICE:ZENER,0.4W,3.0V,2%	04713	SZG30025RL
VR866	152-0195-00		SEMICONV DEVICE:ZENER,0.4W,5.1V,5%	04713	SZ11755
W100	131-0566-00		BUS CONDUCTOR:DUMMY RES,2.375,22 AWG	57668	JWW-0200E0
W540	131-0566-00		BUS CONDUCTOR:DUMMY RES,2.375,22 AWG	57668	JWW-0200E0
W558	131-0566-00		BUS CONDUCTOR:DUMMY RES,2.375,22 AWG	57668	JWW-0200E0
W814	131-0566-00		BUS CONDUCTOR:DUMMY RES,2.375,22 AWG	57668	JWW-0200E0

DIAGRAMS AND CIRCUIT BOARD ILLUSTRATIONS

Symbols

Graphic symbols and class designation letters are based on ANSI Standard Y32.2-1975.

Logic symbology is based on ANSI Y32.14-1973 in terms of positive logic. Logic symbols depict the logic function performed and may differ from the manufacturer's data.

The overline on a signal name indicates that the signal performs its intended function when it is in the low state.

Abbreviations are based on ANSI Y1.1-1972.

Other ANSI standards that are used in the preparation of diagrams by Tektronix, Inc. are:

Y14.15, 1966 Drafting Practices.
 Y14.2, 1973 Line Conventions and Lettering.
 Y10.5, 1968 Letter Symbols for Quantities Used in Electrical Science and Electrical Engineering.

American National Standard Institute
 1430 Broadway
 New York, New York 10018

Component Values

Electrical components shown on the diagrams are in the following units unless noted otherwise:

Capacitors = Values one or greater are in picofarads (pF).
 Values less than one are in microfarads (μ F).

Resistors = Ohms (Ω).

— The information and special symbols below may appear in this manual. —

Assembly Numbers and Grid Coordinates

Each assembly in the instrument is assigned an assembly number (e.g., A20). The assembly number appears on the circuit board outline on the diagram, in the title for the circuit board component location illustration, and in the lookup table for the schematic diagram and corresponding component locator illustration. The Replaceable Electrical Parts list is arranged by assemblies in numerical sequence; the components are listed by component number *(see following illustration for constructing a component number).

The schematic diagram and circuit board component location illustration have grids. A lookup table with the grid coordinates is provided for ease of locating the component. Only the components illustrated on the facing diagram are listed in the lookup table. When more than one schematic diagram is used to illustrate the circuitry on a circuit board, the circuit board illustration may only appear opposite the first diagram on which it was illustrated; the lookup table will list the diagram number of other diagrams that the circuitry of the circuit board appears on.

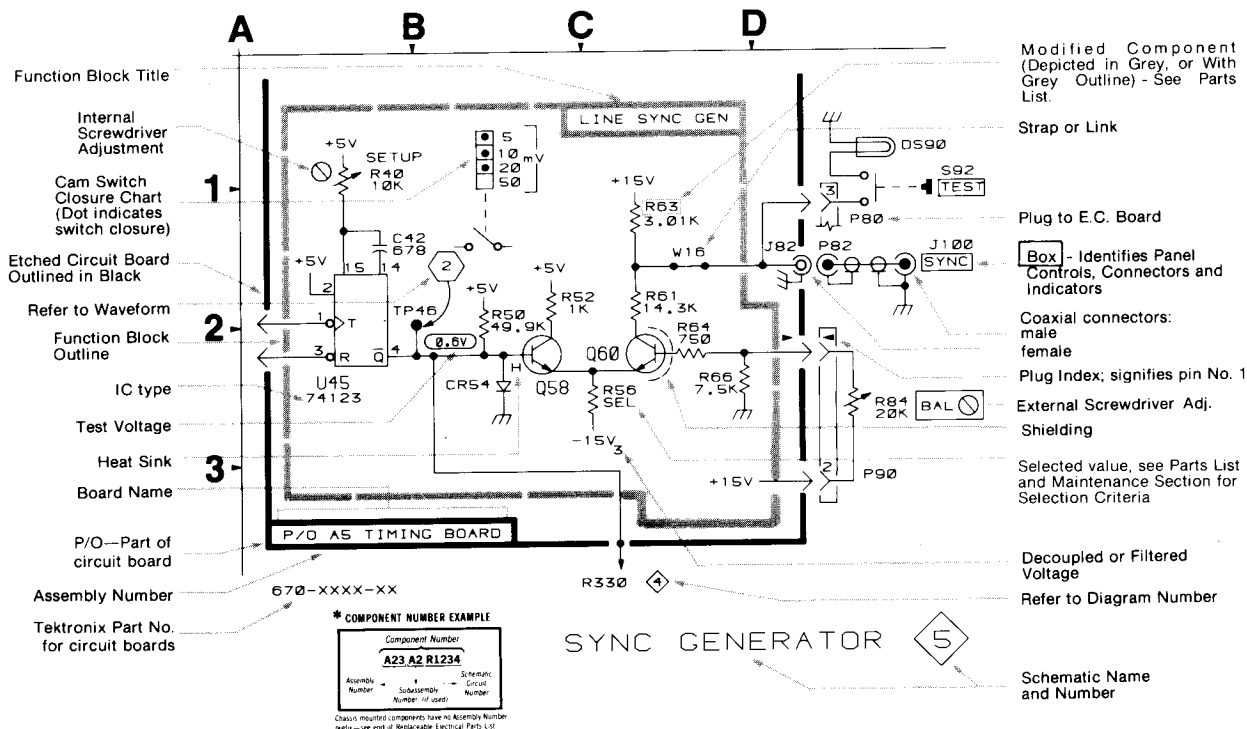

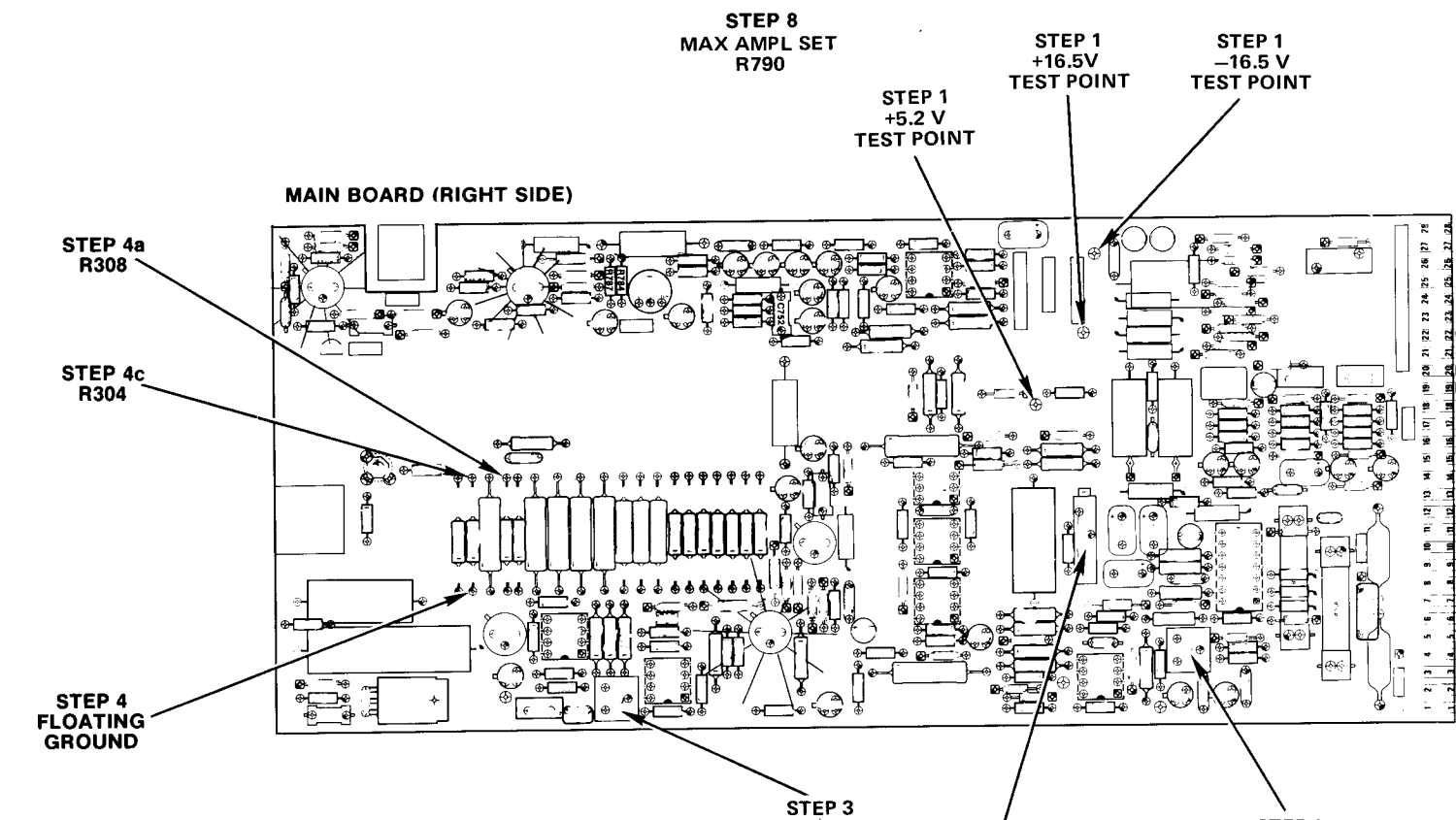

NOTE: STEP 4
 A 20 mA current-source approximation can be built by inserting a 931 Ω , 1% resistor and a 50 Ω potentiometer in series with a 20 V source. A 20 mA current source can also be obtained from another PG 506 AMPL OUTPUT connector. Use the 2 V AMPLITUDE setting and adjust the VARIABLE (OUT) control in a STD AMPL mode.

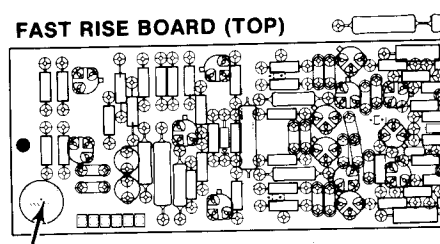

**STEP 10
 MIN AMPL SET
 R1025**

Fig. 8-1. Adjustment locations.

STEP 1
6.5 V
POINT

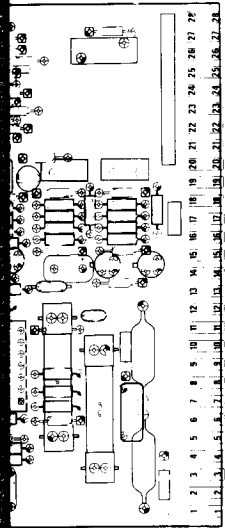

STEP 1
PRIMARY
POWER
R30

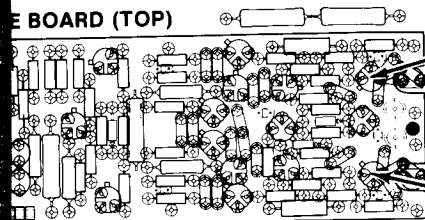

NOTE:
C940 and C1000
LOCATED ON UNDERSIDE
OF BOARD

DVM BOARD (LEFT SIDE)

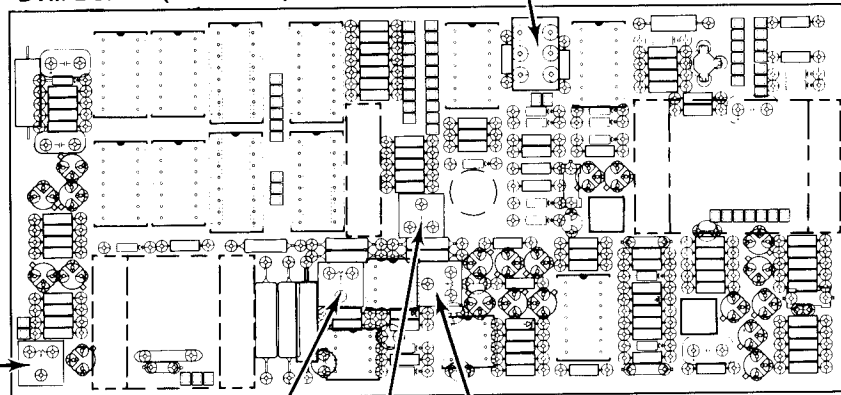

STEP 1-UP
STEP 7-DOWN
S660

STEP 7
PERIOD
R587

STEP 5a
ZERO SET
R450

STEP 5b
-6.8% SET
R425

STEP 5c
+7.3% SET
R415

Adjustment locations.

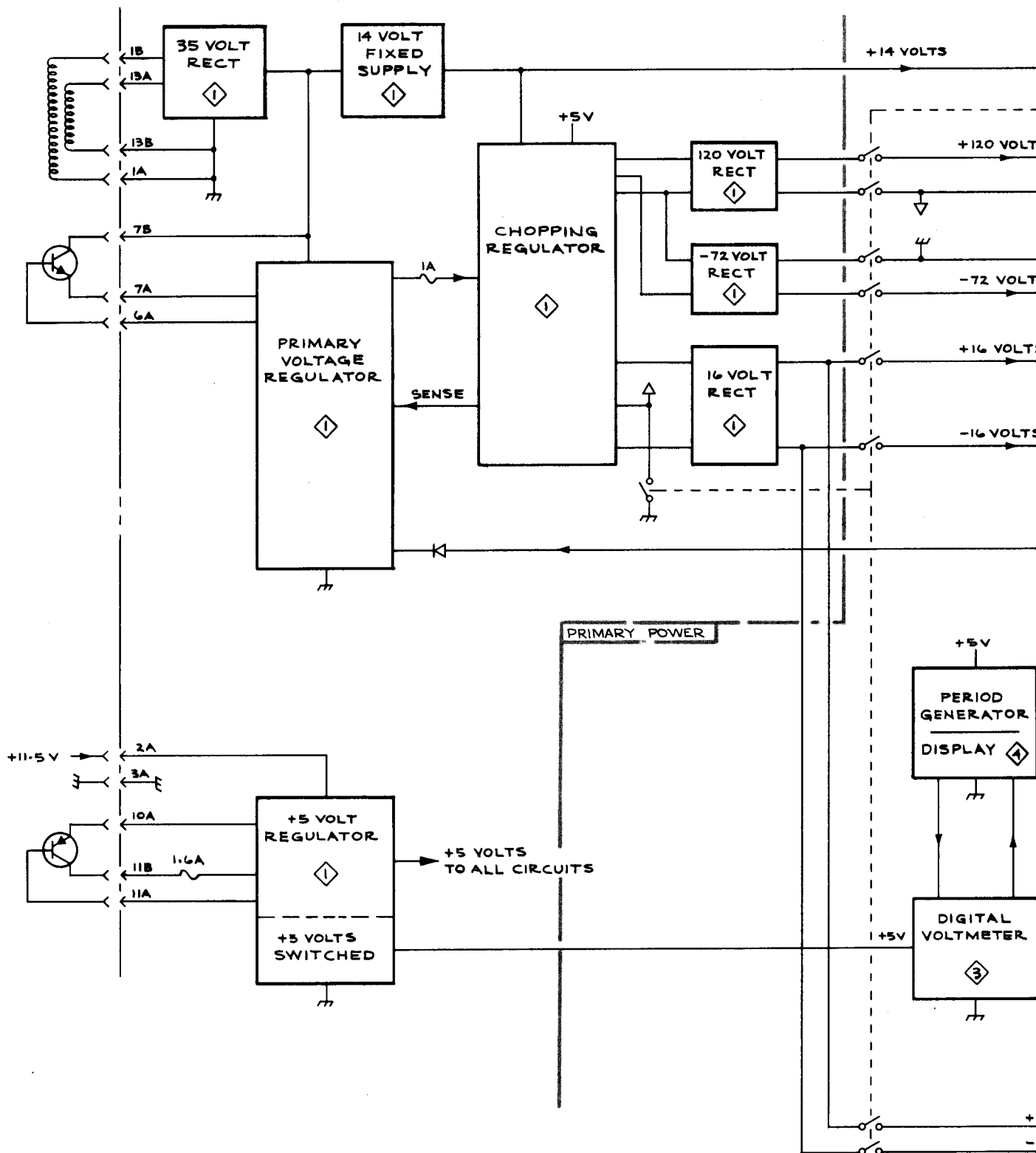

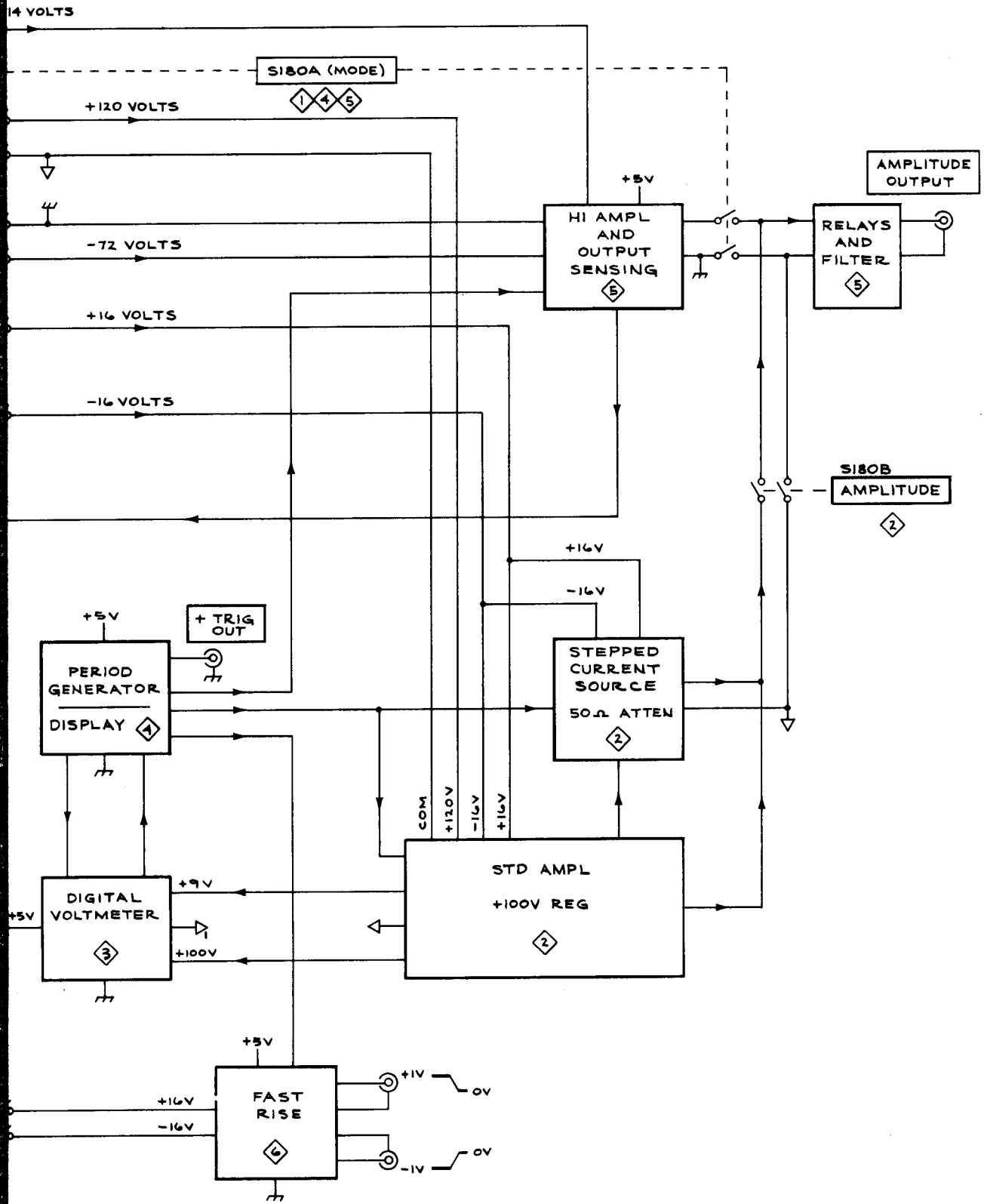

BLOCK DIAGRAM

BLOCK DIAGRAM

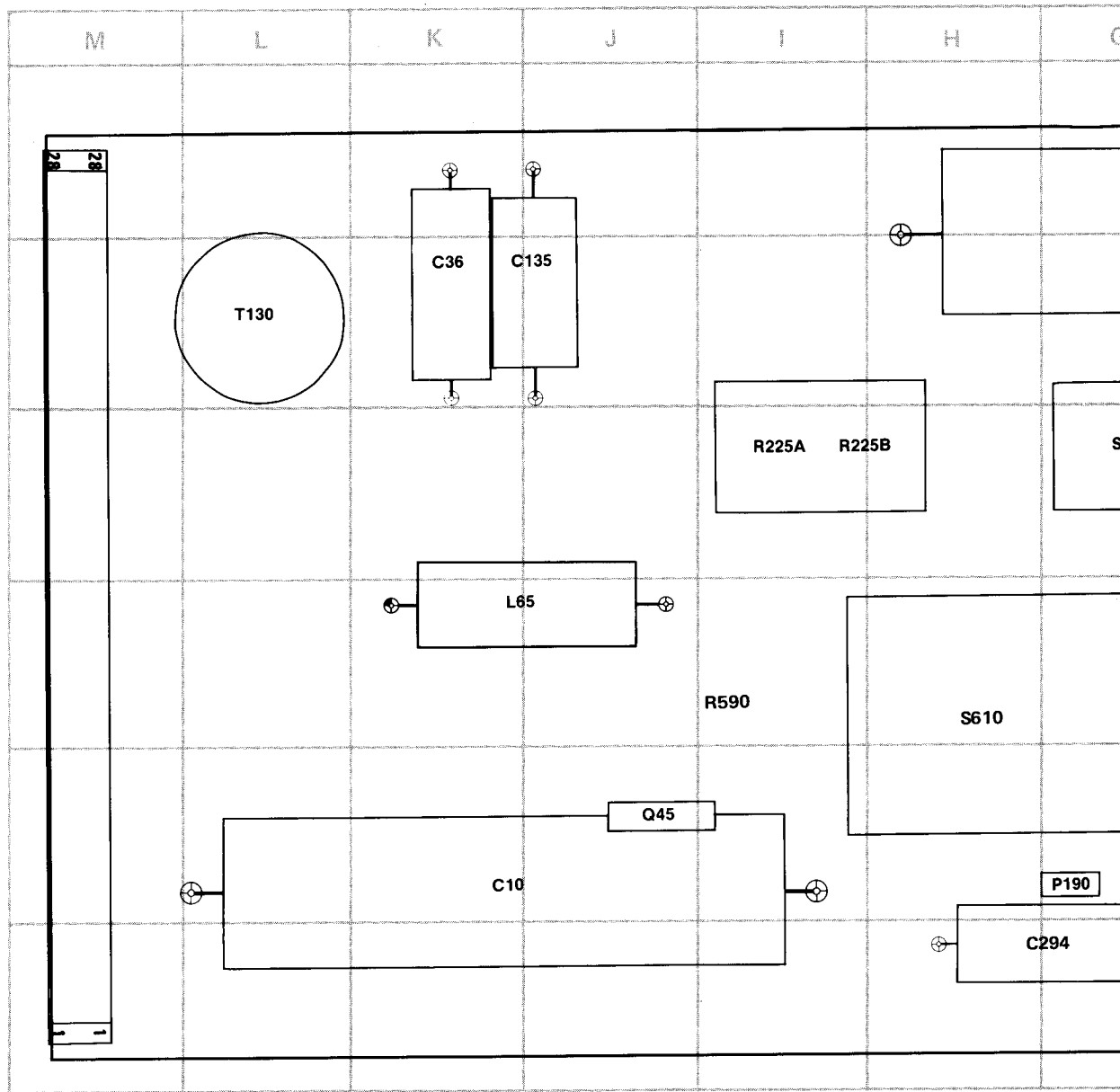

Static Sensitive Devices
 See Maintenance Section

Fig. 8-2. A1—Main Board

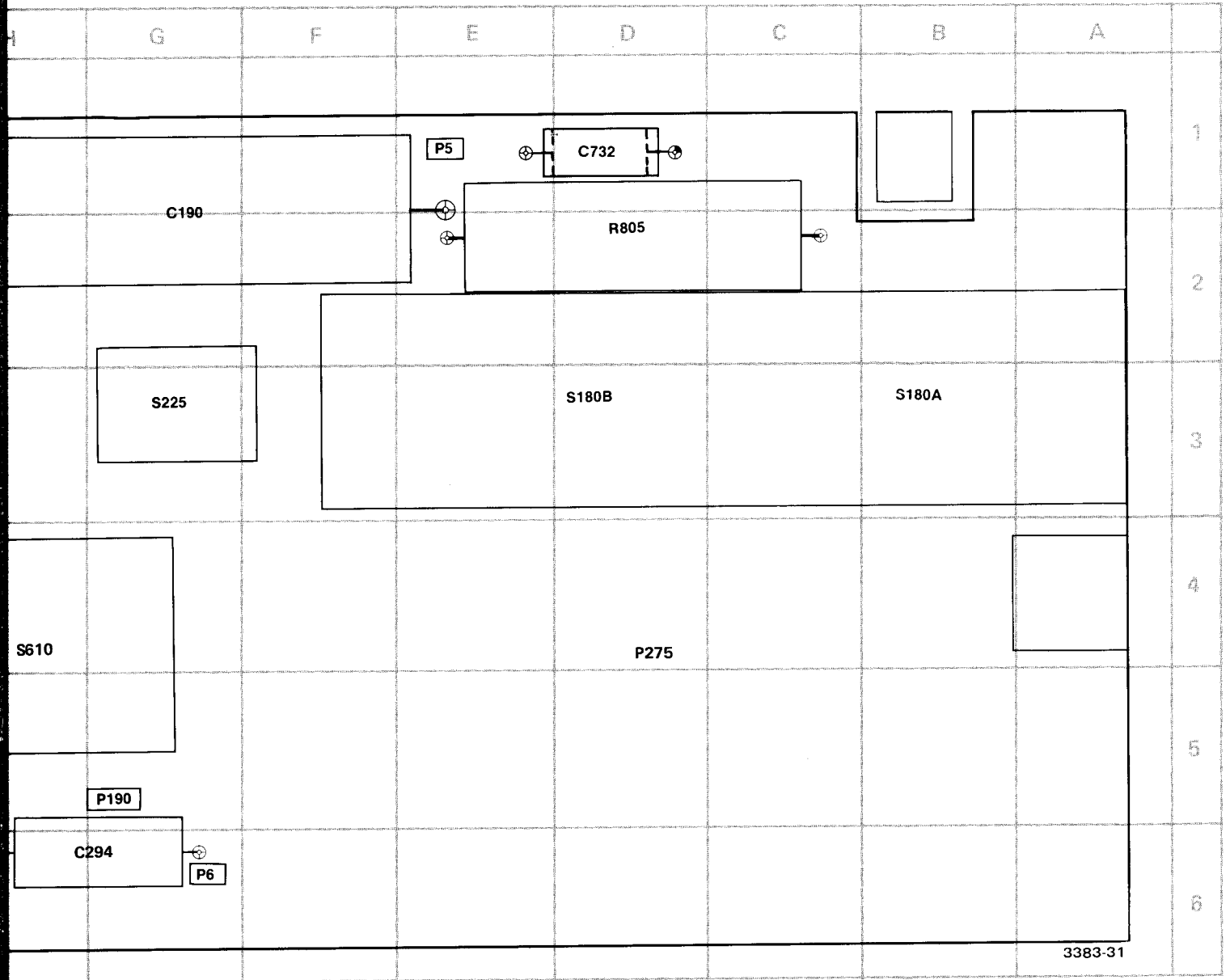

A1 MAIN BOARD "B"
COMPONENT LOCATIONS

2. A1—Main Board "B" component locations.

A1 MAIN BOARD
COMPONENT LOCATIONS

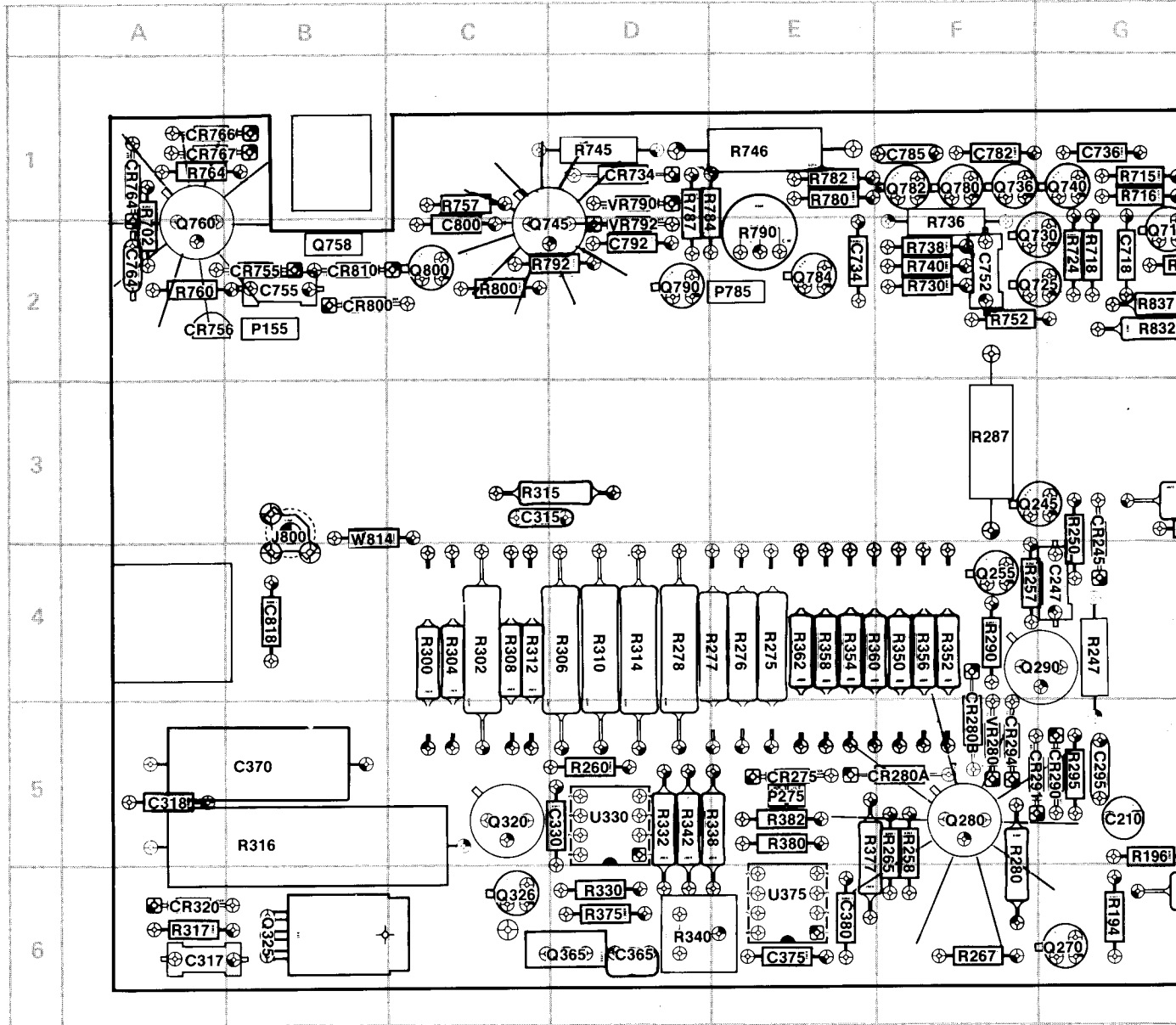

 Static Sensitive Devices
See Maintenance Section

Fig. 8-3. A1—Main Board compo

P/O A1 Assy

Primary Power

1

CIRCUIT NUMBER	SCHEMATIC LOCATION	BOARD LOCATION	CIRCUIT NUMBER	SCHEMATIC LOCATION	BOARD LOCATION	CIRCUIT NUMBER	SCHEMATIC LOCATION	BOARD LOCATION
C10†	A2	K5	CR85	E5	L3	R20	B3	L5
C15	B2	K6	CR105	E3	L3	R21	B3	L5
C20	B3	L5	CR120	E2	L3	R22	C3	L4
C22	B4	K5	CR125	F3	K3	R23	B3	L5
C27	A4	J4	CR135	G3	K1	R25	A4	J4
C30	C4	L4	CR136	G3	K1	R27	A4	J5
C32	C4	J5	CR137	G3	K1	R29	B6	J5
C34	C4	I4	CR138	G3	K1	R30	B6	J6
C36†	D4	K2	CR140	H3	K2	R31	B6	J5
C40	A7	K6	CR145	G4	K2	R40	A7	J6
C42	A8	J5	CR146	G4	K2	R45	A9	J5
C46*	A8	J5	CR147	G4	K2	R52	B8	I6
C65	D9	J4	CR148	G4	K2	R54	B7	J6
C67	D9	L4	CR165	G6	K2	R57	C7	I6
C75	E6	J4	CR166	G6	K2	R60	C8	J6
C78	E6	K3	CR167	G6	K2	R65	D7	M6
C80	E5	M3	CR168	G6	K2	R75	D6	L4
C90	D2	K4	CR170	H5	I3	R80	E5	L3
C100	H5	I3				R82	E5	L3
C125	E2	L3	F30	C4	L4	R85	E5	L3
C135†	H3	J2	F65	D8	L5	R90	D1	K4
C140	J3	J1	L35	C4	J4	R94	D3	K3
C145	G4	J3	L38	D4	L1	R96	D2	K3
C150	H4	J2	L65†	D8	K4	R98	D2	K3
C154	H4	J2	L135	H3	J2	R100	E2	K4
C165	H6	J1	L145	G4	J2	R104	E3	K3
C170	H4	I1	L150	H4	J2	R105	E3	L3
C175	G6	J1	L165	G4	J2	R108	E3	L3
C180	H6	I1	L175	H6	J2	R120	E3	L3
CR10	A1	M6				R122	E3	L3
CR11	A1	L4	P65	J5	I2	R135	G3	K1
CR22	B4	K5	P155	J2	B2	R154	J4	J2
CR27	B6	J5	P225	H4	J2	R170	H5	H3
CR38	E4	L1	Q15	B2	K6	T75	K3	E6
CR55	C7	I6	Q45†	A8	J5	T130†	F3	L2
CR67	E8	I3	Q60	C7	J6			
CR78	F6	K2	Q80	F5	L3	U20	B3	L5
CR80	F4	L3	Q85	F5	M4	U50	B7	J6
			Q90	D2	K2	VR10	B2	L5
			Q100	E2	E2	VR30	B4	L4
			Q120	E3	L4	VR42	A8	J6
			Q125	F3	L3	VR45	A8	J5
			R10	B2	K6	VR55	C7	I6
			R15	B2	K5	VR170	H5	H3

P/O A1 ASSY also shown on

2

5

A5 ASSY

Located on Fig. 8-4

Primary Power

1

C3	K2	J3
CR2	L2	K4
K2	L2	J4
K4	L2	J2

† Located on back of board.

*See Parts List for serial number ranges.

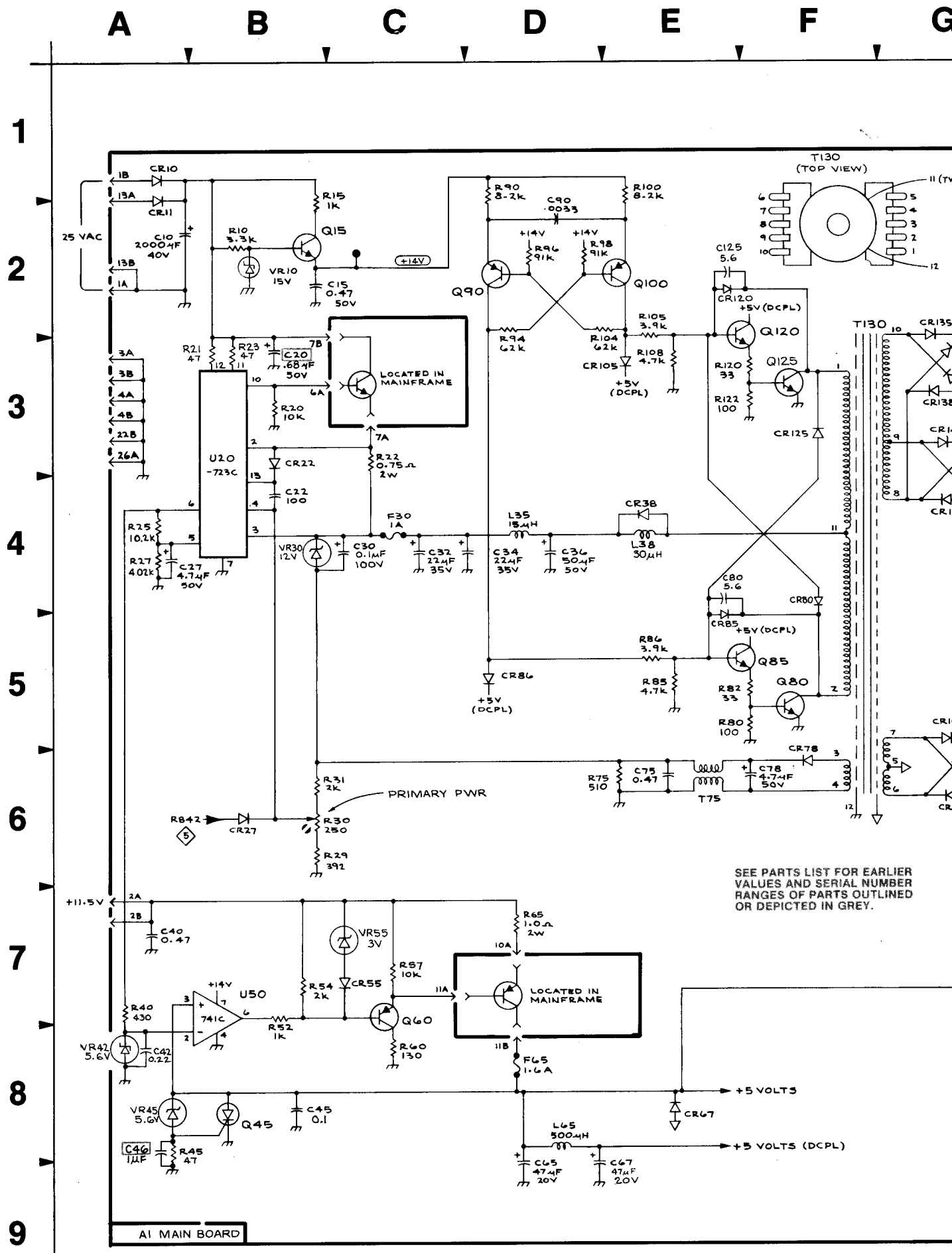

SEE PARTS LIST FOR EARLIER VALUES AND SERIAL NUMBER RANGES OF PARTS OUTLINED OR DEPICTED IN GREY.

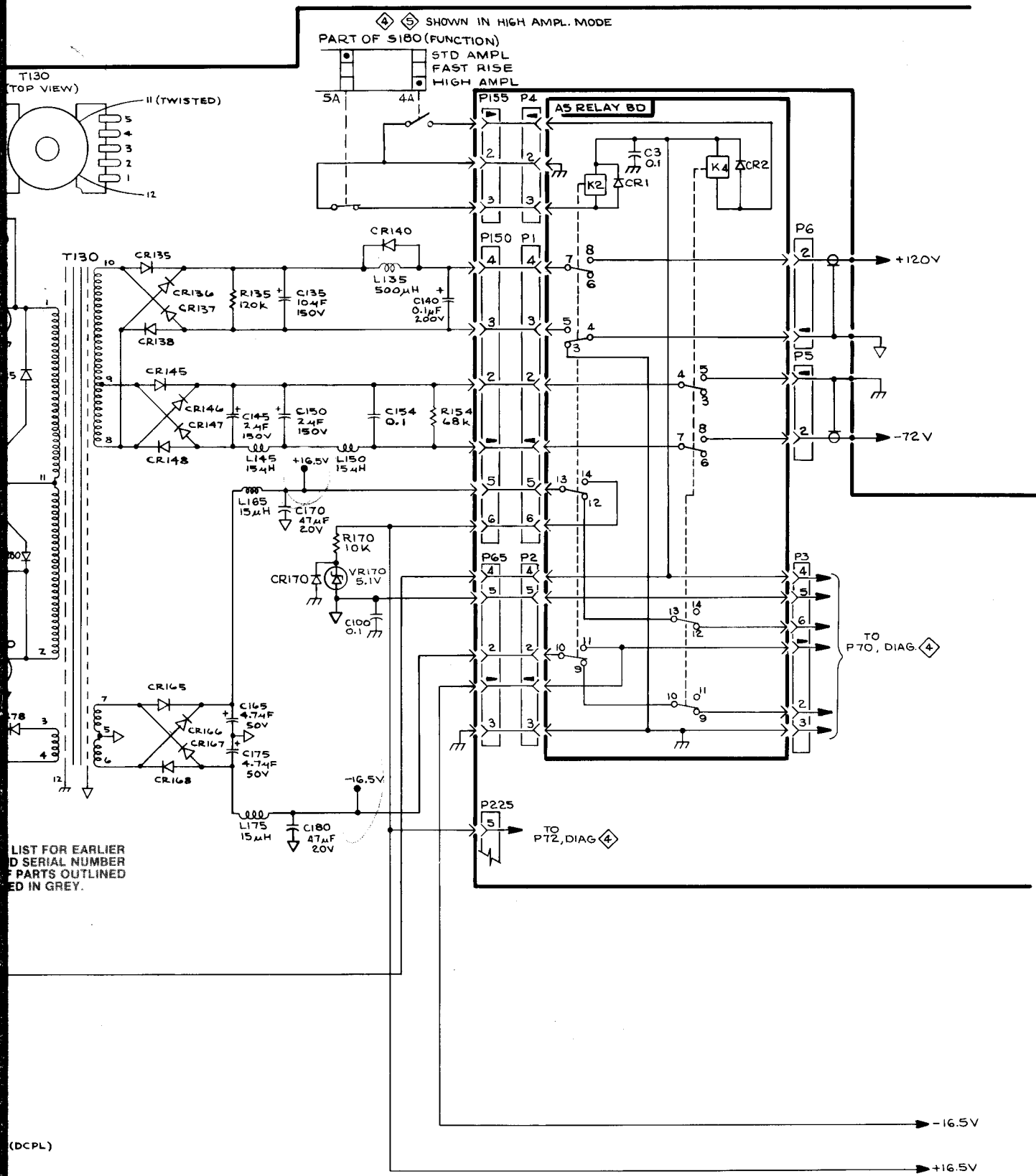

LIST FOR EARLIER
 SERIAL NUMBER
 PARTS OUTLINED
 IN GREY.

(DCPL)

P/O A1 Assy

Standard Amplitude 2

CIRCUIT NUMBER	SCHEMATIC LOCATION	BOARD LOCATION	CIRCUIT NUMBER	SCHEMATIC LOCATION	BOARD LOCATION	CIRCUIT NUMBER	SCHEMATIC LOCATION	BOARD LOCATION
C190†	C5	G1	R210	C7	H6	R382	G1	E5
C196	C6	H5	R212	C7	I5	S225†	B9	G3
C198	C6	I4	R215	D7	I5	S225†	E8	G3
C200	B6	I4	R220	D7	I3	U200	D6	H5
C210	D8	G5	R225A†	D7	G3	U240	F7	H4
C212	D7	H5	R225B†	D7	G3	U255	G8	H4
C237	F6	H4	R230	D7	I3	U330	H4	D5
C240	F7	H5	R234	E6	H3	U375	H2	E6
C247	F7	G4	R237	E7	H3	VR210	C7	I5
C294†	F6	G6	R238	F7	H4	VR280	H6	F5
C295	F6	G5	R245	F7	G4			
C315	L5	C3	R247	G7	G4			
C317	J5	A6	R250	G7	G4			
C318	J5	A5	R255	F9	H3			
C330	J4	D5	R256	F8	H3			
C365	K3	D6	R257	F8	F4			
C370	K1	B5	R258	G9	F5			
C375	H2	E6	R260	H8	D5			
C380	H2	E6	R265	H8	F5			
CR70	C8	H3	R267	H8	F6			
CR190	C6	H5	R275	J8	E4			
CR196	D6	G5	R276	J7	E4			
CR235	E7	H5	R277	J7	E4			
CR245	F7	G4	R278	J6	D4			
CR275	J8	E5	R280	H6	F5			
CR280A	J6	F5	R287	H6	F3			
CR280B	H6	F5	R290	G6	F4			
CR290	F6	G5	R295	F6	G5			
CR291	F6	F5	R300	L5	C4			
CR294	F6	F5	R302	L5	C4			
CR320	K4	A6	R304	K5	C4			
P190†	M7	G5	R306	K5	D4			
P225	C8	I2	R308	K5	C4			
P225	C9	I2	R310	K5	D4			
Q190	C6	H5	R312	K5	C4			
Q245	G7	G3	R314	K4	D4			
Q255	G8	F4	R315	L5	C3			
Q270	H8	G6	R316	K5	B5			
Q280	H6	F5	R317	J5	A6			
Q290	G6	G4	R330	J4	D4			
Q320	J4	C5	R332	H4	D5			
Q325	K4	B6	R338	H4	E5			
Q326	J4	C6	R340	H4	D6			
Q365	K2	D6	R342	H4	D5			
R190	C5	H6	R350	H2	F4			
R194	D5	G6	R352	H3	E2			
R196	D6	G5	R354	J2	E4			
R200	B6	I5	R356	J3	F4			
R205	C6	I4	R358	J3	E4			
R207	B6	I6	R360	J3	E4			
			R375	J2	D6			
			R377	H2	E5			
			R380	G2	E5			

P/O A1 ASSY also shown on 1 5

† Located on back of board.

A B C D E F

1
2
3
4
5
6
7
8
9

AI MAIN BOARD

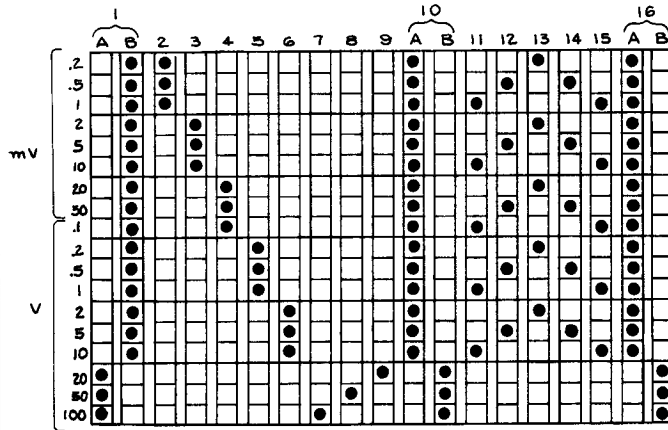

S180B - AMPLITUDE
VOLTS INTO 1MΩ

- NOTES:
- INDICATES CONTACT CLOSED
 - SHOWN IN 100V POSITION
 - UNLESS OTHERWISE NOTED ALL CONTACTS SHOWN ON THIS PAGE ARE S180B

SEE PARTS LIST FOR EARLIER VALUES AND SERIAL NUMBER RANGES OF PARTS OUTLINED OR DEPICTED IN GREY.

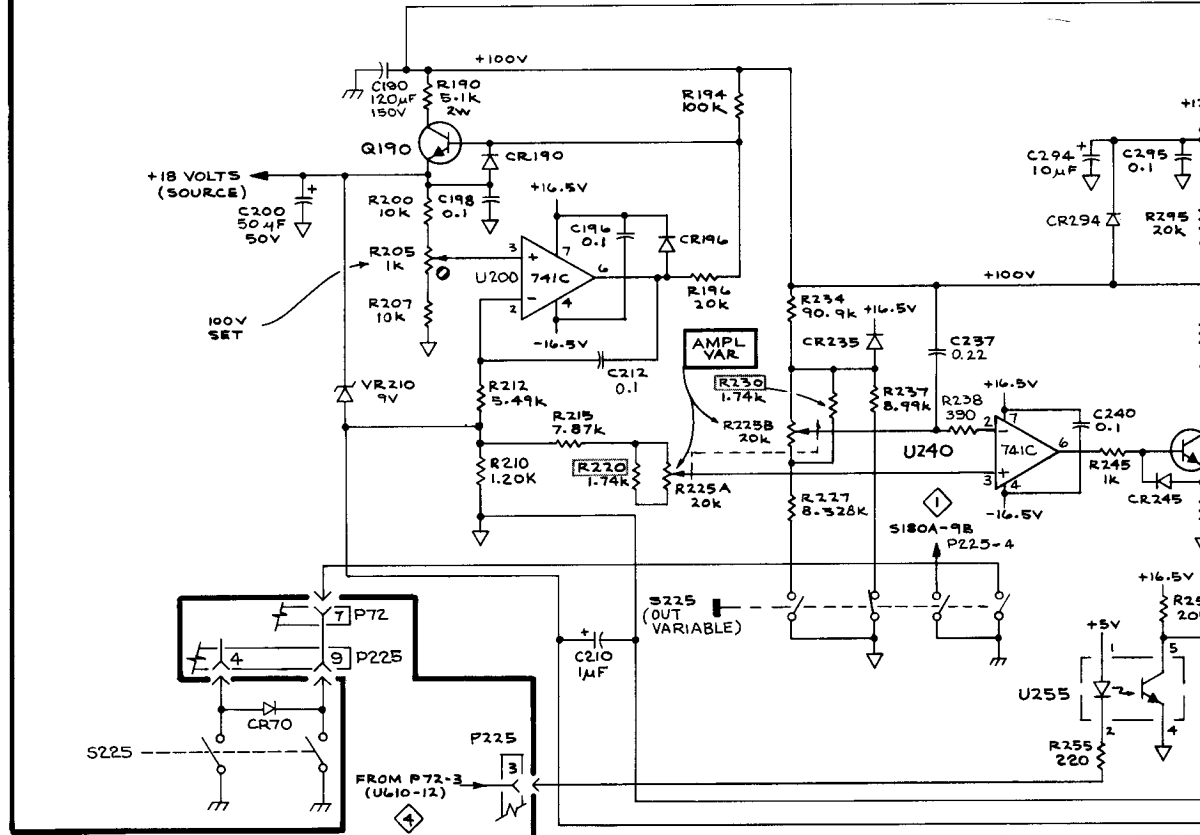

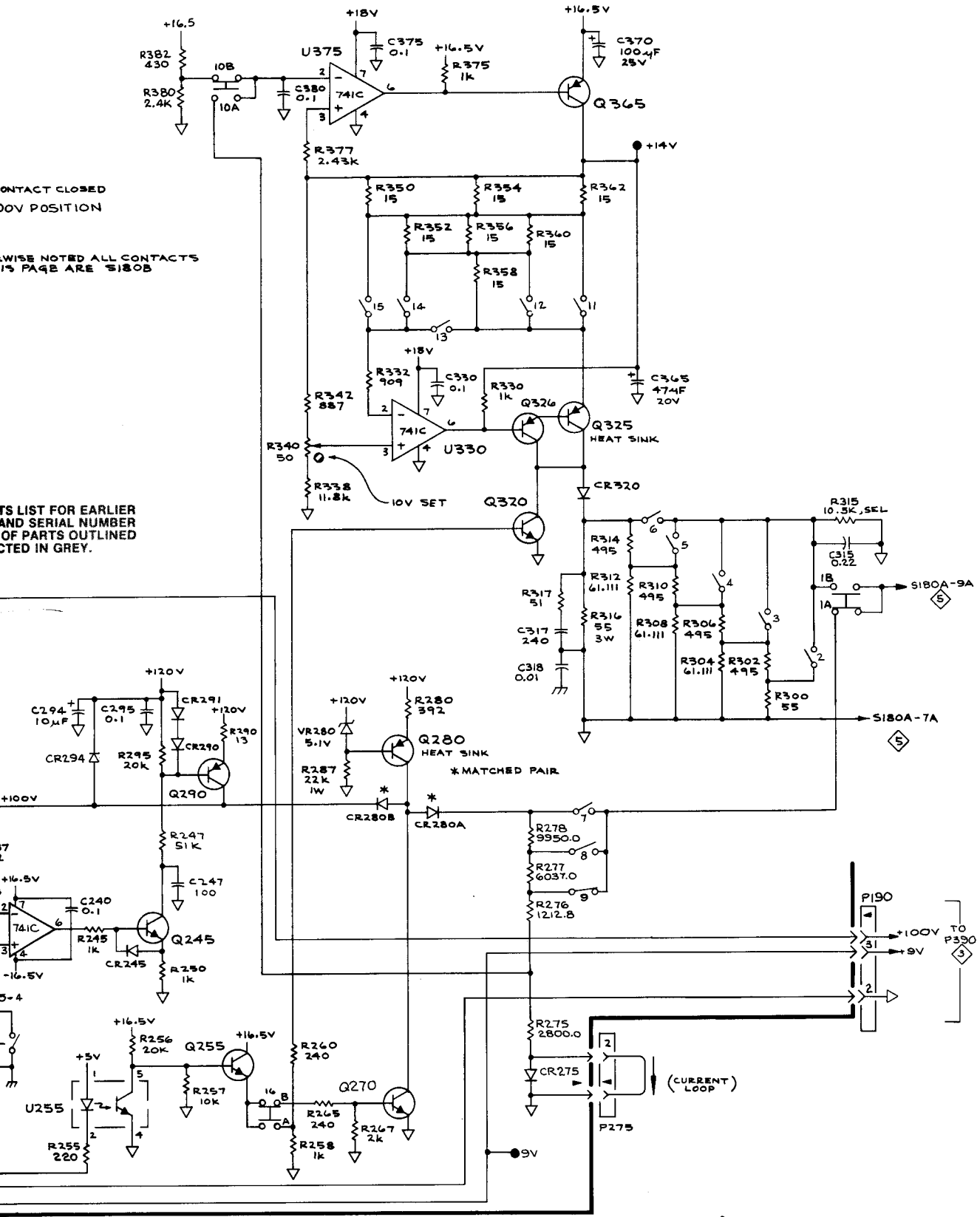

CONTACT CLOSED
00V POSITION

UNLESS NOTED ALL CONTACTS
ON THIS PAGE ARE S180B

LIST FOR EARLIER
AND SERIAL NUMBER
OF PARTS OUTLINED
IN GREY.

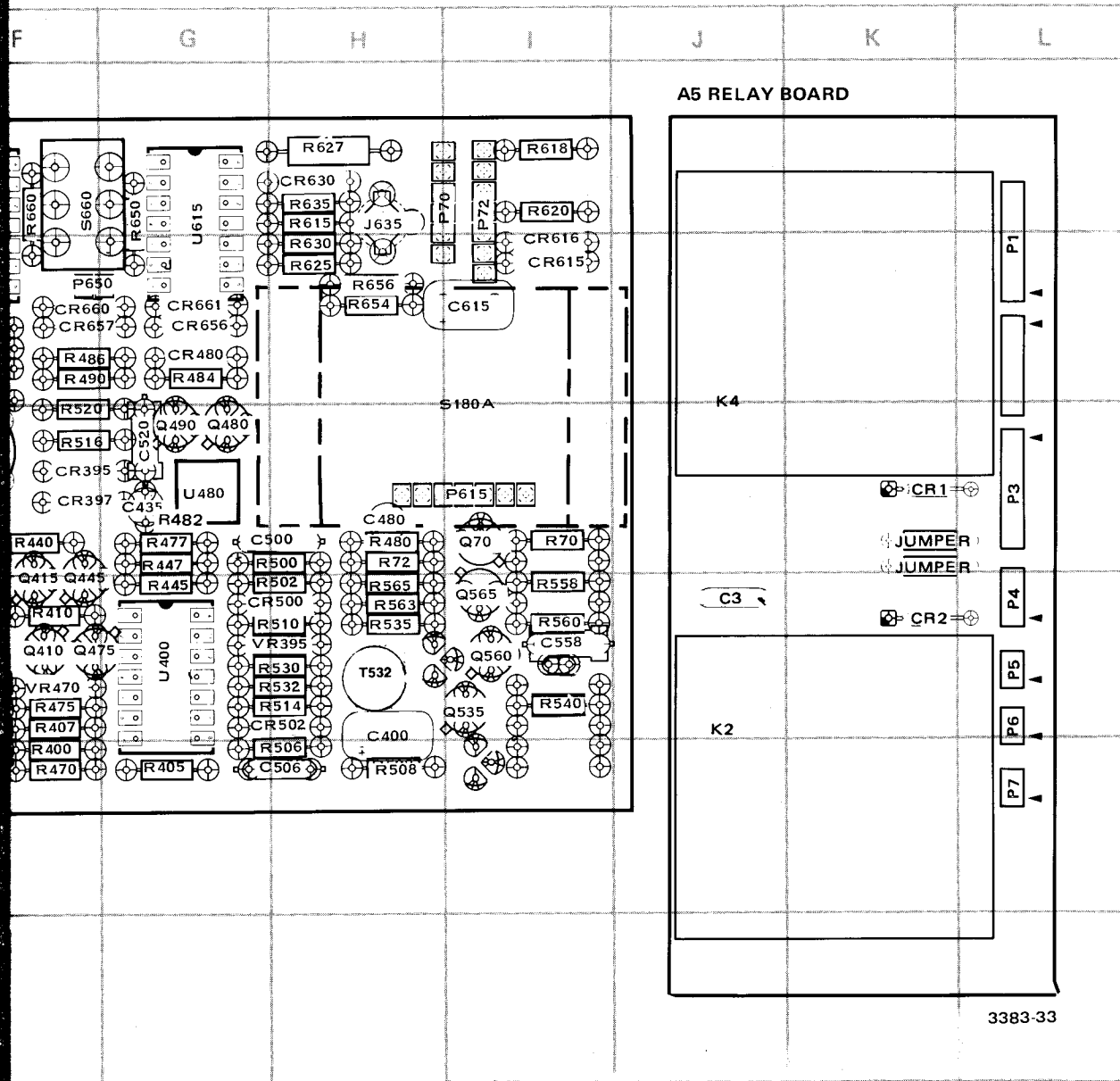

⊗ Static Sensitive Devices
See Maintenance Section

Display Board component locations.

P/O A2 Assy			Digital Voltmeter 3		
CIRCUIT NUMBER	SCHEMATIC LOCATION	BOARD LOCATION	CIRCUIT NUMBER	SCHEMATIC LOCATION	BOARD LOCATION
C390	B1	C4	R440	D7	F3
C392	B2	C5	R445	D7	G4
C400	E5	H4	R447	E6	G3
C420	B7	F4	R450	A3	D4
C435	D6	G3	R452	A4	D4
C460	B4	E4	R454	A3	D4
C465	B5	D4	R460	B4	D4
C470	C4	F5	R465	C4	E5
C474	C3	F4	R470	F5	F4
C480	G2	H3	R475	F4	F4
C500	F4	H3	R477	F4	G3
C506	G5	H5	R480	F2	H3
C520	J5	G3	R482	F3	G3
C558	K4	I4	R484	G2	G2
CR395	C2	F3	R486	G3	F2
CR397	C3	F3	R490	G3	F2
CR465	C4	E5	R495	J2	A6
CR466	C4	E4	R500	G4	H3
CR480	G2	G2	R502	G4	H4
CR484	J2	B6	R506	G4	H5
CR485	J2	B6	R508	G5	H5
CR500	G4	H4	R510	G4	H4
CR520	J5	F2	R514	G4	H4
DS480	H2	A6	R516	H5	F3
DS482	J2	A6	R520	J5	F3
P390	B1	C5	R524	K6	C3
P673	H2	E2	R530	H4	H4
P702	H2	C6	R532	H4	H4
Q410	B8	F4	R535	J4	H4
Q415	B8	F4	R560	K4	I4
Q435	D6	F4	R563	K3	H4
Q440	D7	F3	R565	L3	H4
Q445	D7	F3	T520	J5	F3
Q475	F4	G4	T532	J4	H4
Q480	G2	G3	U400A	E7	G4
Q490	G3	G3	U400B	E8	G4
Q535	H5	I4	U400C	H4	G4
Q560	K4	I4	U400D	H5	G4
Q565	K4	I4	U430	C6	E4
R400	E8	F5	U460	B4	D4
R405	B8	G5	U470	D4	F4
R407	B8	F4	U480	F3	G3
R410	B7	F4	VR395	D2	H4
R415	B7	E3	VR430	C6	E4
R417	B7	D3	VR470	D4	F4
R420	B7	D3	W540	J4	I4
R423	B6	E3	W558	J4	I4
R425	B6	E4			
R427	B6	D3			
R430	B6	E3			
R435	D6	E4			

P/O A2 ASSY also shown on 4

P/O A4 ASSY			Digital Voltmeter 3		
CR484	J2	B6	R495	J3	A6
CR485	J2	B6	P702	H2	C6
DS480	H2	A5			
DS482	J2	A6			

A B C D E F

1
2
3
4
5
6
7
8
9

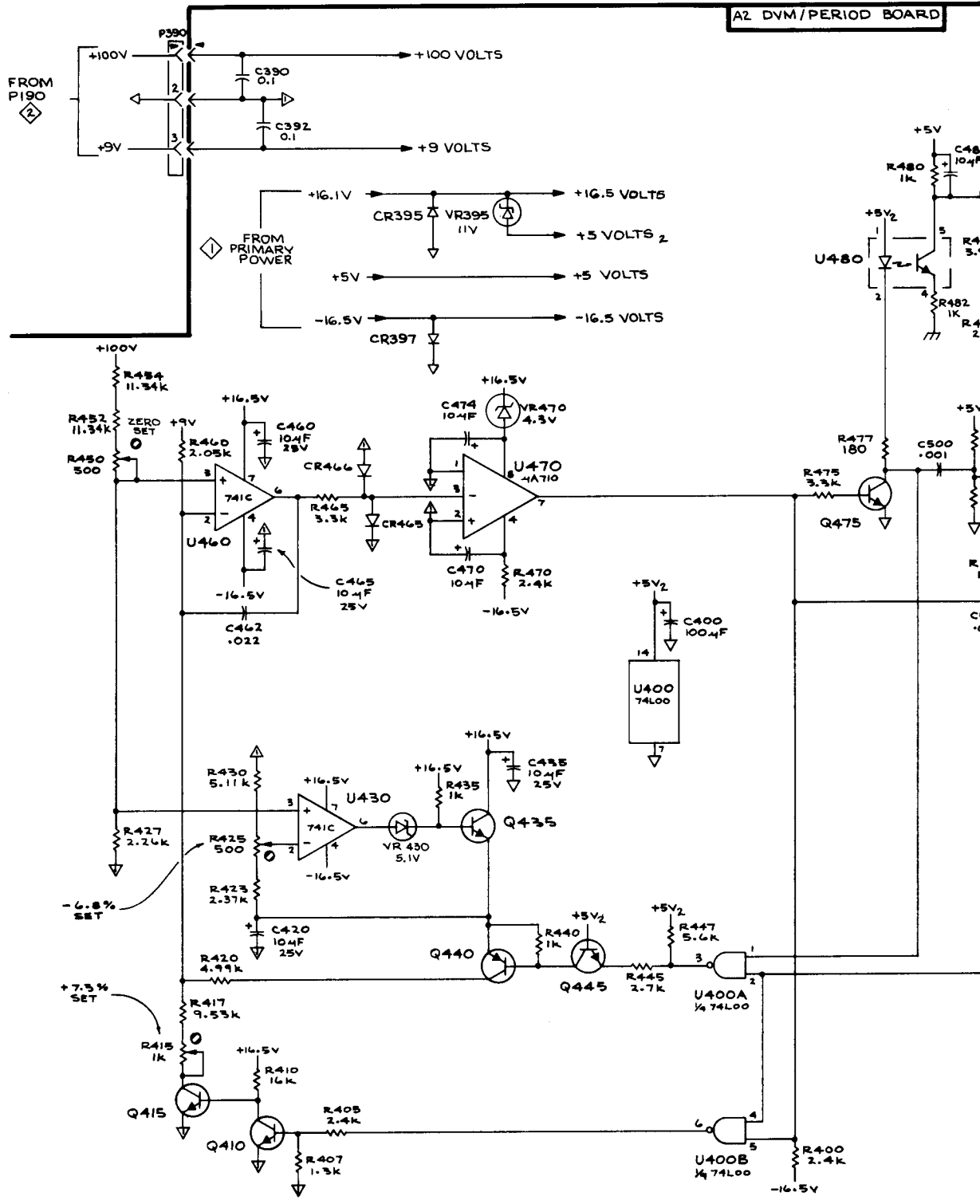

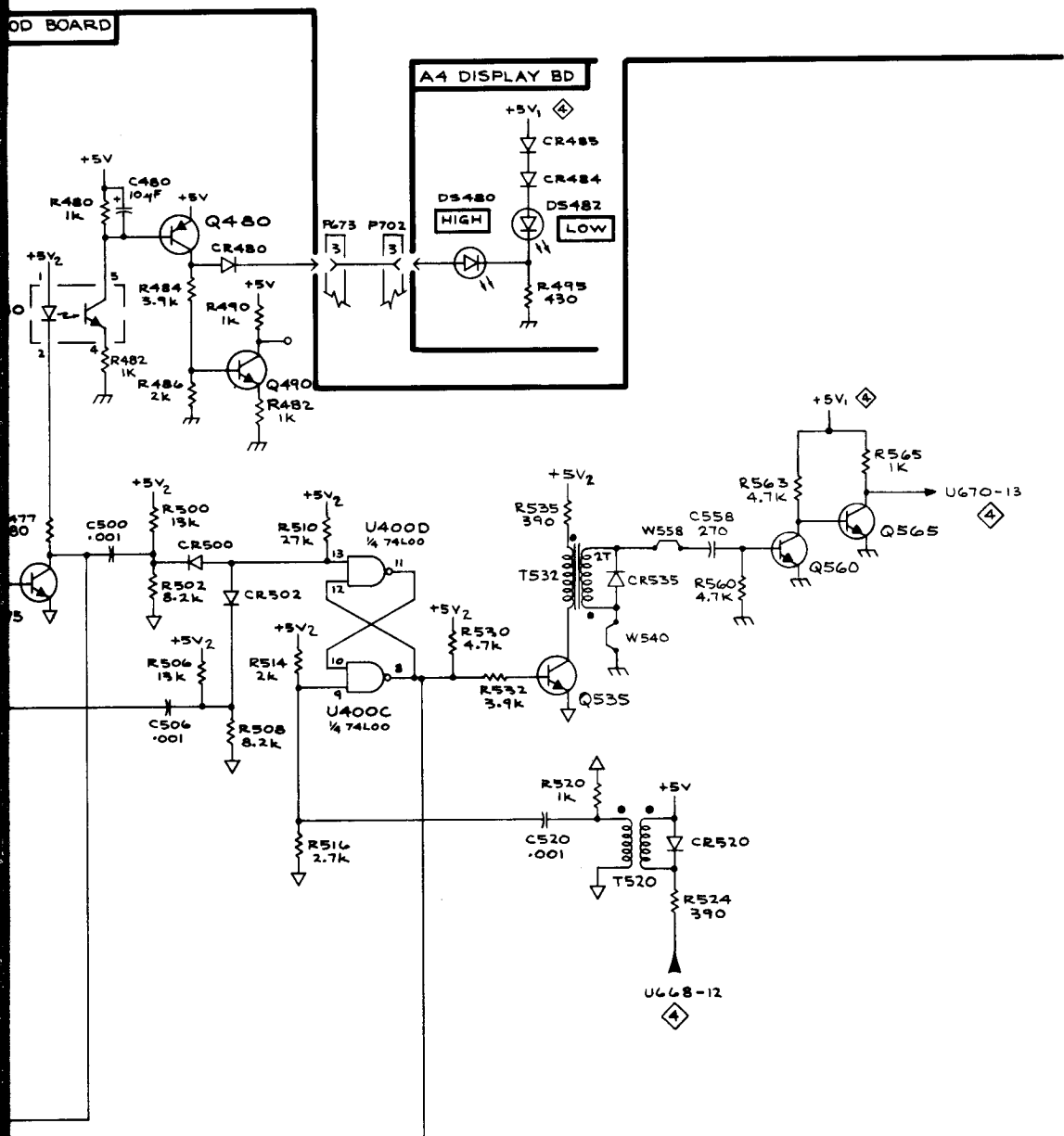

DIGITAL VOLTMETER



P/O A2 Assy			DVM Period Board 4		
CIRCUIT NUMBER	SCHEMATIC LOCATION	BOARD LOCATION	CIRCUIT NUMBER	SCHEMATIC LOCATION	BOARD LOCATION
C580	C2	A2	R615	J2	H1
C582	D1	B1	R618	J2	I1
CR576	A1	A2	R620	K2	I1
CR615	J2	I2	R625	K2	H2
CR616	J2	I2	R627	K2	H1
CR630	L3	H1	R630	K3	H1
CR656	J4	G2	R635	L3	H1
CR657	J4	F2	R650	K4	G1
CR660	H4	F2	R654	K3	H2
CR661	H4	G2	R656	J4	H2
CR668	F8	B3	R660	H3	F1
J635	L3	H1	R680	H5	E2
L582	D1	A2	R681	H5	E3
P70	B4	I1	R682	H5	E3
P72	L2	I1	R683	J5	E2
P72	L3	I1	R684	J5	E2
P72	C8	I1	R685	J5	F2
P590	C2	A4	R686	J5	F2
P615	B4	I3	R690	H7	E1
P650	K5	G2	R691	H7	E2
P673	K5	E2	R692	J7	E2
P675	K7	E1	R693	J7	E1
Q70	C6	I3	R694	J7	E1
Q575	B1	B3	R695	K7	E1
Q580	B1	A3	R696	K7	E1
Q585	C2	B2	R705	K8	F2
Q595	C3	B4	S180A	G1	I2
Q605	C3	B5	S610	E2	C4
Q610	C3	A4	S660	G4	F1
R70	C6	I3	U610	F3	F1
R72	C7	H3	U610	H3	F1
R575	A2	B2	U615	K2	G1
R576	A2	B2	U665	D5	B3
R578	B1	A3	U666	D6	C3
R582	D1	A2	U667	D7	C1
R585	C2	A2	U668	E8	B1
R587	C2	A5	U670	F6	C3
R593	C2	A4	U671	F7	C2
R595	C3	A3	U673	G6	D3
R597	B3	A3	U675	G7	D1
R600	B3	A3			
R602	C3	A4			
R605	D3	A4			
R606	D2	A4			
P/O A2 ASSY also shown on 3					
P/O A4 ASSY			DVM Period Board 4		
DS700	M5	C6			
DS702	M7	C6			
R700	M7	B6			

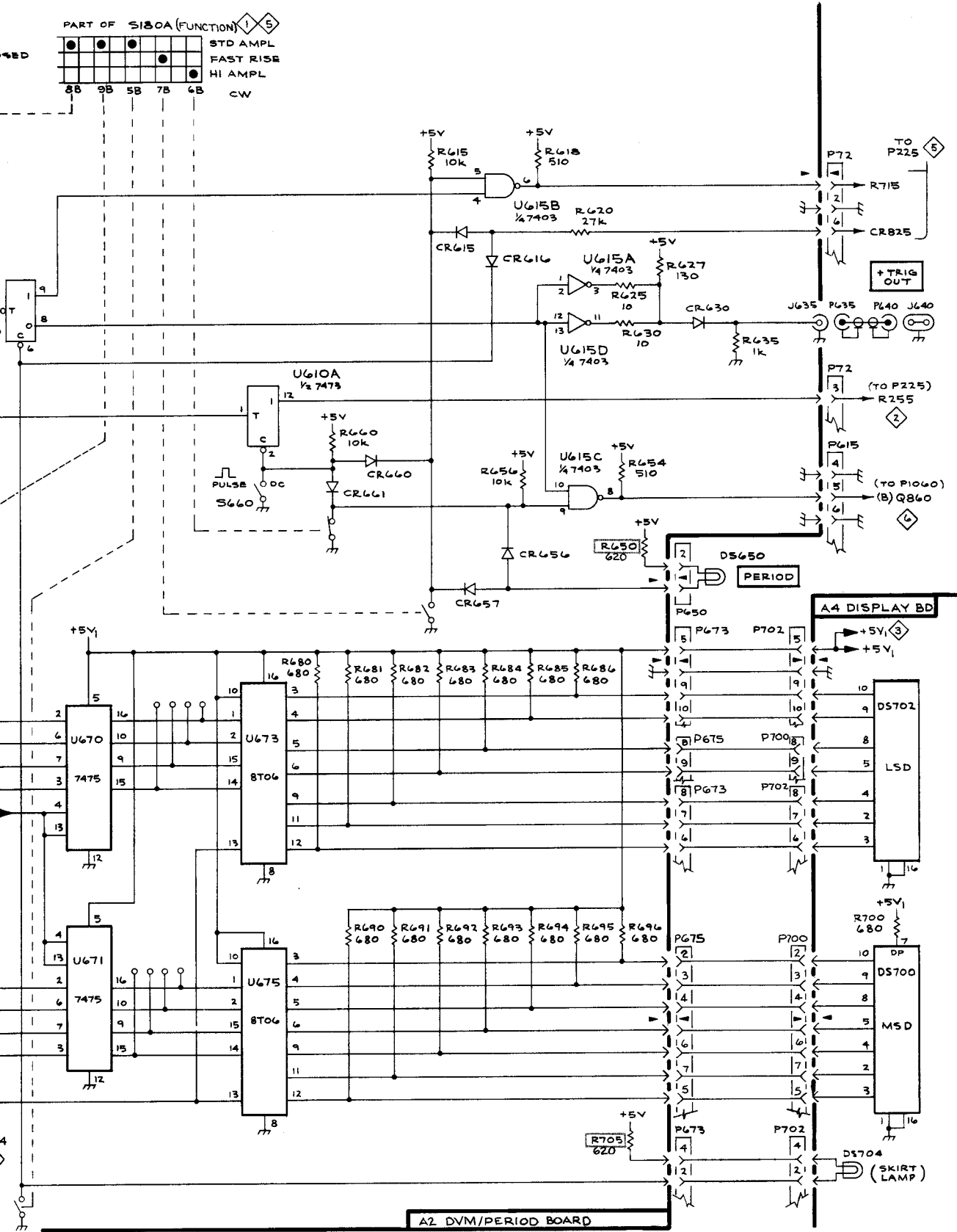
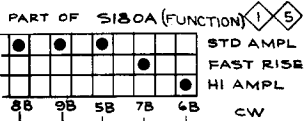

PERIOD GENERATOR AND DISPLAY

3383-24
REV MAY 1983

PERIOD GENERATOR AND DISPLAY 4

P/O A1 Assy			High Amplitude 5		
CIRCUIT NUMBER	SCHEMATIC LOCATION	BOARD LOCATION	CIRCUIT NUMBER	SCHEMATIC LOCATION	BOARD LOCATION
C718	B4	G2	R715	B5	G1
C732	B7	D1	R716	B6	G1
C734	C7	E2	R718	B4	G2
C736	D7	G2	R724	B5	G2
C752	D6	F2	R730	C6	F2
C755	E5	B2	R736	D6	F2
C764	D4	A2	R738	D6	F2
C782	F7	F1	R740	D6	F2
C785	G7	F1	R745	D6	D1
C792	G6	D2	R746	D6	E1
C800	G4	C2	R752	D6	F2
C818†	H6	B4	R757	E5	C1
C840	H3	H1	R760	D3	A2
CR734	C7	D1	R762	D4	A2
CR755	E5	B2	R764	C4	A1
CR756	E5	A2	R780	E6	E1
CR764	B4	A1	R782	E7	E1
CR766	D4	A1	R784	F7	E1
CR767	D4	A1	R787	F6	D1
CR800	G4	B2	R790	F5	E2
CR810	H5	B2	R792	G5	C2
CR825	H2	H2	R800	G4	C2
J800	L5	B3	R805†	H5	D2
P225	A5	I2	R825	H2	H2
Q715	B5	G2	R827	H3	G7
Q725	C5	G2	R830	G2	H7
Q730	C5	G2	R832	G4	G2
Q736	D6	F1	R835	F3	F3
Q740	D6	G1	R837	F4	G2
Q745	D5	C2	R840	H4	H1
Q758	D5	B2	R842	J4	H1
Q760	D4	A2	U840	H3	H1
Q780	E6	F2	VR790	G6	D1
Q782	E7	F2	VR792	G6	D2
Q784	F6	E2	R785A	G6	CHASSIS
Q790	G6	D2	P785	G6	CHASSIS
Q800	G5	C2	R785	G6	CHASSIS

P/O A1 ASSY also shown on 1 2

† Located on back of board.

A B C D E F

1
2
3
4
5
6
7
8
9

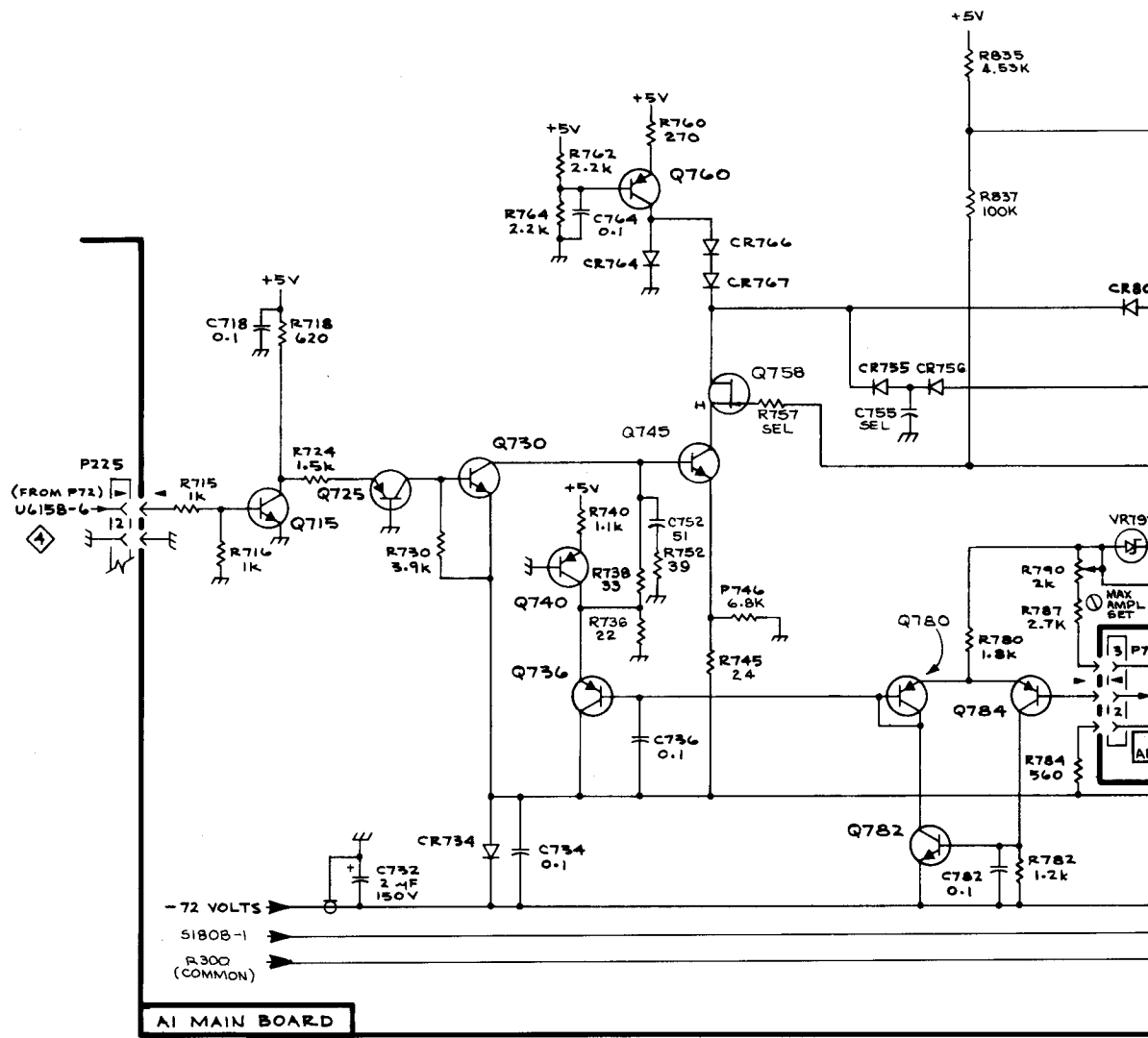

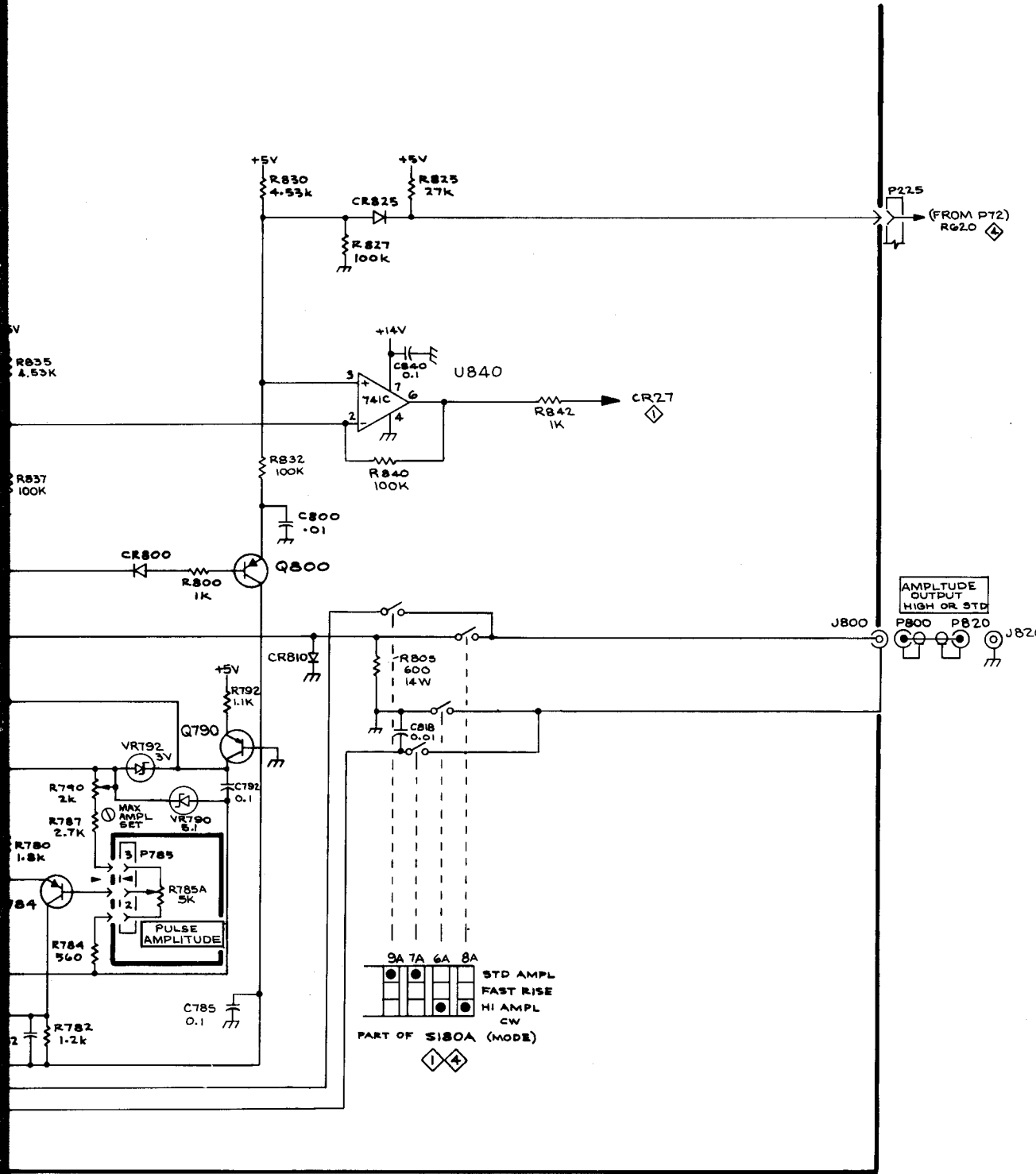

HIGH AMPLITUDE

High Amplitude 5

5

A3 Assy

Fast Rise 

CIRCUIT NUMBER	SCHEMATIC LOCATION	BOARD LOCATION	CIRCUIT NUMBER	SCHEMATIC LOCATION	BOARD LOCATION
C886	C2	D2	R874	B3	C2
C904	E4	D3	R876	B3	C1
C906	E4	D3	R880	C3	B1
C914	E2	E2	R882	D5	D2
C928	J1	E2	R884	C2	D2
C938	J1	E2	R886	C3	D2
C940	K3	F2	R890	D2	D2
C962	E5	D1	R892	D6	D2
C966	E5	D1	R900	D3	D2
C974	D7	E2	R902	D4	D3
C988	J7	E1	R904	E4	D2
C998	K7	F1	R910	F3	D2
C1000	K6	F2	R914	E2	E2
C1026	G4	A3	R916	E2	E3
C1028	G4	A2	R918	E2	E2
C1034	H4	E2	R920	H3	E2
C1045	H5	F2	R924	H2	E2
C1060	B6	B2	R928†	J1	E3
C1062	B7	B2	R930†	J2	F3
C1065	B7	B2	R935	J2	F3
C1067	B7	B2	R937	K2	F2
C1070	B7	B3	R938	K2	F3
			R940	K3	F2
CR944	K3	F2	R944	K3	F2
CR1004	K6	F1	R950	L3	F3
CR1028	G4	A1	R960	D6	D2
CR1047	G5	E2	R962	E5	D1
CR1048	H5	E2	R964	E5	D1
CR1062	B7	B2	R966	E5	D1
CR1067	B7	B1	R970	E6	D2
			R974	E7	E1
P1025	F5	A3	R976	E7	E1
P1060	A3	B3	R978	E7	E1
			R980	H7	E2
Q850	B4	C2	R984	H7	E1
Q860	B3	C3	R988†	H7	E1
Q862	B3	C1	R990†	J7	F1
Q880	C3	D2	R995	J6	F1
Q890	D3	D2	R997	K7	E1
Q900	D3	D3	R998	K7	F1
Q910	E3	D2	R1000	K6	F2
Q920†	H2	E2	R1004	K6	F1
Q935	J2	F2	R1010	L6	F2
Q960	D6	D1	R1020	G3	A2
Q970	E6	D2	R1021	G3	B2
Q980	H7	E1	R1025	G4	A3
Q995	J7	F2	R1026	G4	A2
Q1020	H3	B2	R1028	G4	A1
Q1030	H4	B1	R1030	G4	A1
Q1036	H4	E2	R1034	H4	B1
Q1045	H5	F2	R1036	H4	E2
			R1040	H5	E2
R850	B5	B2	R1045	H6	E2
R854	B5	C2	R1047	G5	B1
R855	A4	B2	VR866	B3	C2
R857	A4	C2	VR866	D3	C2
R860	B4	B2			
R862	B4	C2			
R865	B4	C2			
R866	C3	C1			
R870	C3	B3	J950	L3	CHASSIS
R871	B3	C2	J1010	L6	CHASSIS

A B C D E F

1
2
3
4
5
6
7
8
9

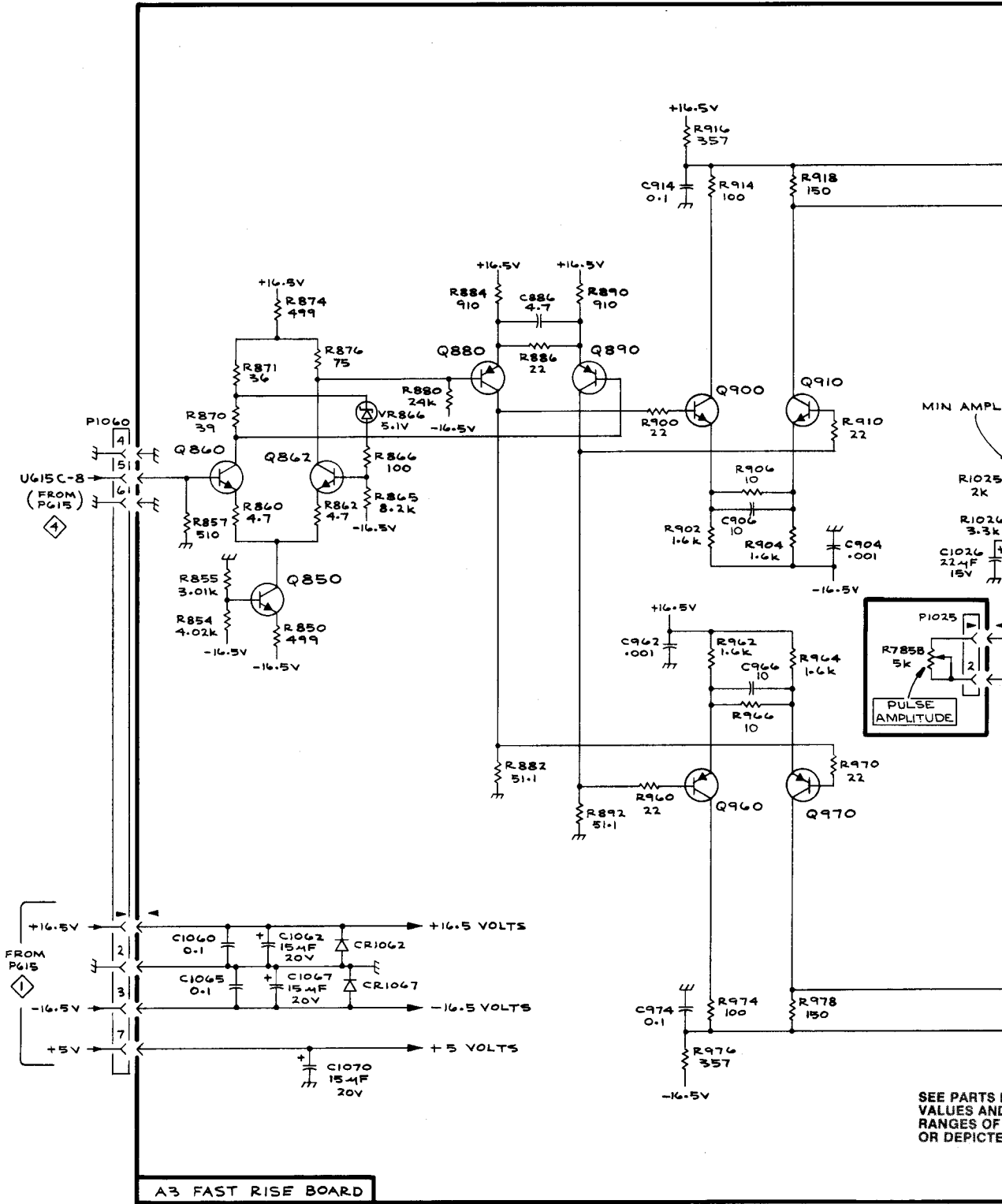

MIN AMPL
R1025 2k
R1026 3.3k
C1026 22µF 15V

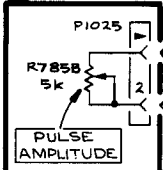

SEE PARTS L
VALUES AND
RANGES OF F
OR DEPICTED

A3 FAST RISE BOARD

PG 506 (SN B040000 & UP)

3383-27
REV APR 1984

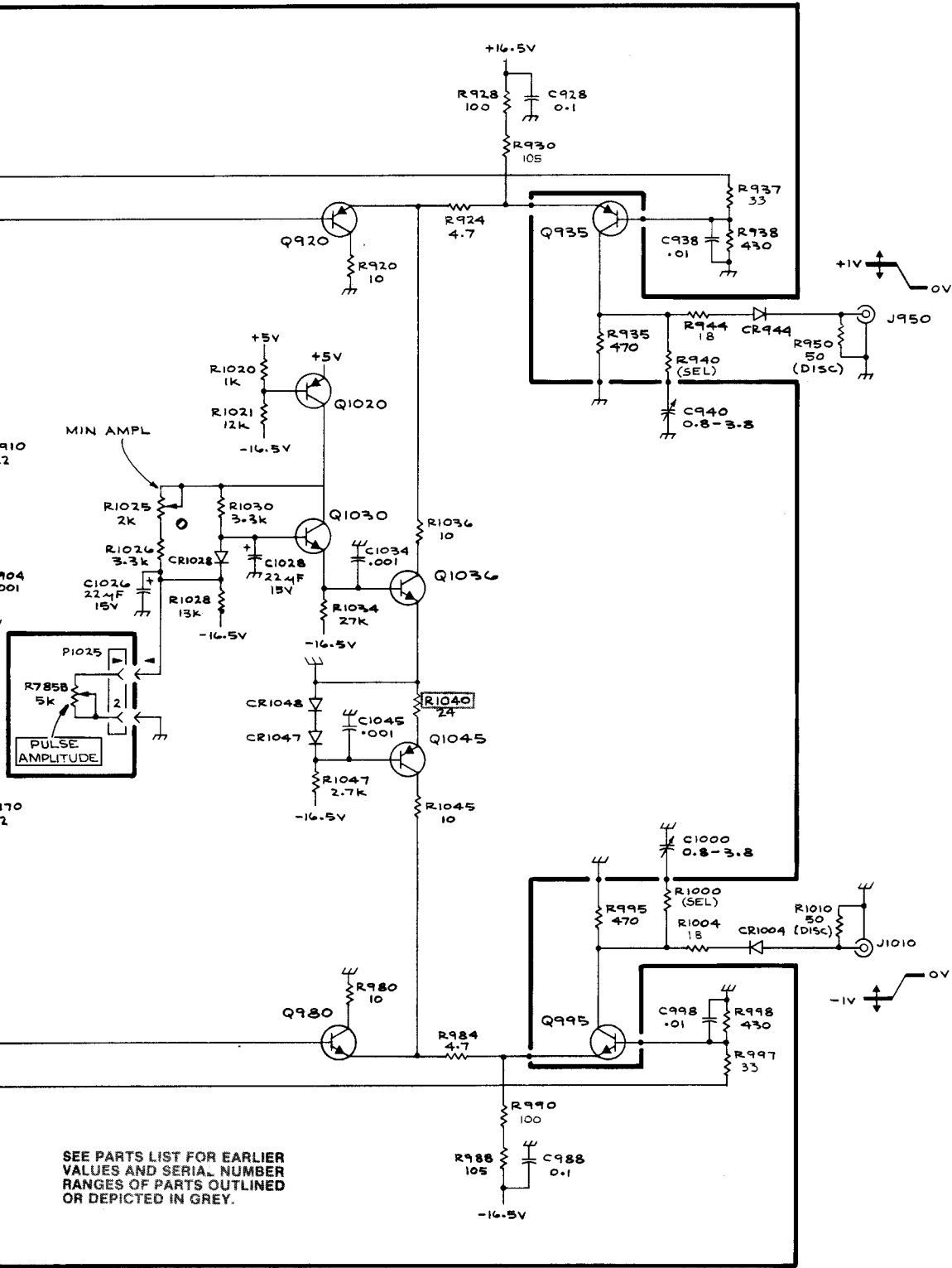

SEE PARTS LIST FOR EARLIER VALUES AND SERIA. NUMBER RANGES OF PARTS OUTLINED OR DEPICTED IN GREY.

REPLACEABLE MECHANICAL PARTS

PARTS ORDERING INFORMATION

Replacement parts are available from or through your local Tektronix, Inc. Field Office or representative.

Changes to Tektronix instruments are sometimes made to accommodate improved components as they become available, and to give you the benefit of the latest circuit improvements developed in our engineering department. It is therefore important, when ordering parts, to include the following information in your order: Part number, instrument type or number, serial number, and modification number if applicable.

If a part you have ordered has been replaced with a new or improved part, your local Tektronix, Inc. Field Office or representative will contact you concerning any change in part number.

Change information, if any, is located at the rear of this manual.

SPECIAL NOTES AND SYMBOLS

X000 Part first added at this serial number
00X Part removed after this serial number

FIGURE AND INDEX NUMBERS

Items in this section are referenced by figure and index numbers to the illustrations.

INDENTATION SYSTEM

This mechanical parts list is indented to indicate item relationships. Following is an example of the indentation system used in the description column.

```

1 2 3 4 5           Name & Description
Assembly and/or Component
Attaching parts for Assembly and/or Component
    ---- * ----
Detail Part of Assembly and/or Component
Attaching parts for Detail Part
    ---- * ----
Parts of Detail Part
Attaching parts for Parts of Detail Part
    ---- * ----
  
```

Attaching Parts always appear in the same indentation as the item it mounts, while the detail parts are indented to the right. Indented items are part of, and included with, the next higher indentation. The separation symbol --- * --- indicates the end of attaching parts.

Attaching parts must be purchased separately, unless otherwise specified.

ITEM NAME

In the Parts List, an Item Name is separated from the description by a colon (:). Because of space limitations, an Item Name may sometimes appear as incomplete. For further Item Name identification, the U.S. Federal Cataloging Handbook H6-1 can be utilized where possible.

ABBREVIATIONS

#	INCH NUMBER SIZE	ELCTRN	ELECTRON	IN	INCH	SE	SINGLE END
ACTR	ACTUATOR	ELEC	ELECTRICAL	INCAND	INCANDESCENT	SECT	SECTION
ADPTR	ADAPTER	ELCTLT	ELECTROLYTIC	INSUL	INSULATOR	SEMICOND	SEMICONDUCTOR
ALIGN	ALIGNMENT	ELEM	ELEMENT	INTL	INTERNAL	SHLD	SHIELD
AL	ALUMINUM	EPL	ELECTRICAL PARTS LIST	LPHLDR	LAMPHOLDER	SHLDR	SHOULDERED
ASSEM	ASSEMBLED	EQPT	EQUIPMENT	MACH	MACHINE	SKT	SOCKET
ASSY	ASSEMBLY	EXT	EXTERNAL	MECH	MECHANICAL	SL	SLIDE
ATTEN	ATTENUATOR	FIL	FILLISTER HEAD	MTG	MOUNTING	SLFLKG	SELF-LOCKING
AWG	AMERICAN WIRE GAGE	FLEX	FLEXIBLE	NIP	NIPPLE	SLVG	SLEEVEING
BD	BOARD	FLH	FLAT HEAD	NON WIRE	NOT WIRE WOUND	SPR	SPRING
BRKT	BRACKET	FLTR	FILTER	OBD	ORDER BY DESCRIPTION	SQ	SQUARE
BRS	BRASS	FR	FRAME or FRONT	OD	OUTSIDE DIAMETER	SST	STAINLESS STEEL
BRZ	BRONZE	FSTNR	FASTENER	OVH	OVAL HEAD	STL	STEEL
BSHG	BUSHING	FT	FOOT	PH BRZ	PHOSPHOR BRONZE	SW	SWITCH
CAB	CABINET	FXD	FIXED	PL	PLAIN or PLATE	T	TUBE
CAP	CAPACITOR	GSKT	GASKET	PLSTC	PLASTIC	TERM	TERMINAL
CER	CERAMIC	HDL	HANDLE	PN	PART NUMBER	THD	THREAD
CHAS	CHASSIS	HEX	HEXAGON	PNH	PAN HEAD	THK	THICK
CKT	CIRCUIT	HEX HD	HEXAGONAL HEAD	PWR	POWER	TNSN	TENSION
COMP	COMPOSITION	HEX SOC	HEXAGONAL SOCKET	RCPT	RECEPTACLE	TPG	TAPPING
CONN	CONNECTOR	HLCPS	HELICAL COMPRESSION	RES	RESISTOR	TRH	TRUSS HEAD
COV	COVER	HLEXT	HELICAL EXTENSION	RGD	RIGID	V	VOLTAGE
CPLG	COUPLING	HV	HIGH VOLTAGE	RLF	RELIEF	VAR	VARIABLE
CRT	CATHODE RAY TUBE	IC	INTEGRATED CIRCUIT	RTNR	RETAINER	W/	WITH
DEG	DEGREE	ID	INSIDE DIAMETER	SCH	SOCKET HEAD	WSHR	WASHER
DWR	DRAWER	IDNT	IDENTIFICATION	SCOPE	OSCILLOSCOPE	XFMR	TRANSFORMER
		IMPLR	IMPELLER	SCR	SCREW	XSTR	TRANSISTOR

Replaceable Mechanical Parts—PG 506 (SN B040000 -Up)

CROSS INDEX—MFR. CODE NUMBER TO MANUFACTURER

Mfr. Code	Manufacturer	Address	City, State, Zip
000BB	BERQUIST COMPANY	4350 WEST 78TH	MINNEAPOLIS, MN 55435
000BK	STAUFFER SUPPLY	105 SE TAYLOR	PORTLAND, OR 97214
000CY	NORTHWEST FASTENER SALES, INC.	7923 SW CIRRUSS DRIVE	BEAVERTON, OR 97005
000EX	O'HARA METAL PRODUCT COMPANY	542 BRANNAN STREET	SAN FRANCISCO, CA 94107
05820	WAKEFIELD ENGINEERING, INC.	AUDUBON ROAD	WAKEFIELD, MA 01880
08261	SPECTRA-STRIP CORP.	7100 LAMPSON AVE.	GARDEN GROVE, CA 92642
09922	BURNDY CORPORATION	RICHARDS AVENUE	NORWALK, CT 06852
13103	THERMALLOY COMPANY, INC.	2021 W VALLEY VIEW LANE P O BOX 34829	DALLAS, TX 75234
22526	BERG ELECTRONICS, INC.	YOUK EXPRESSWAY	NEW CUMBERLAND, PA 17070
24931	SPECIALITY CONNECTOR CO., INC.	2620 ENDRESS PLACE	GREENWOOD, IN 46142
42838	NATIONAL RIVET AND MFG. CO.	1-21 EAST JEFFERSON ST.	WAUPUN, WI 53963
45722	USM CORP., PARKER-KALON FASTENER DIV.		CAMPBELLSVILLE, KY 42718
49671	RCA CORPORATION	30 ROCKEFELLER PLAZA	NEW YORK, NY 10020
57668	R-OHM CORP.	16931 MILLIKEN AVE.	IRVINE, CA 92713
70278	ALLIED STEEL AND CONVEYORS, DIV. OF SPARTON CORP.		
71785	TRW, CINCH CONNECTORS	17333 HEALY	DETROIT, MI 48212
73743	FISCHER SPECIAL MFG. CO.	1501 MORSE AVENUE	ELK GROVE VILLAGE, IL 60007
73803	TEXAS INSTRUMENTS, INC., METALLURGICAL MATERIALS DIV.	446 MORGAN ST.	CINCINNATI, OH 45206
78189	ILLINOIS TOOL WORKS, INC. SHAKEPROOF DIVISION	34 FOREST STREET	ATTLEBORO, MA 02703
79807	WROUGHT WASHER MFG. CO.	ST. CHARLES ROAD	ELGIN, IL 60120
80009	TEKTRONIX, INC.	2100 S. O BAY ST.	MILWAUKEE, WI 53207
83330	SMITH, HERMAN H., INC.	P O BOX 500	BEAVERTON, OR 97077
83385	CENTRAL SCREW CO.	812 SNEDIKER AVE.	BROOKLYN, NY 11207
86928	SEASTROM MFG. COMPANY, INC.	2530 CRESCENT DR.	BROADVIEW, IL 60153
93907	TEXTRON INC. CAMCAR DIV	701 SONORA AVENUE	GLENDALE, CA 91201
97464	INDUSTRIAL RETAINING RING CO.	600 18TH AVE 57 CORDIER ST.	ROCKFORD, IL 61101 IRVINGTON, NJ 07111

Fig. & Index No.	Tektronix Part No.	Serial/Model No.		Qty	Name & Description					Mfr Code	Mfr Part Number
		Eff	Dscont		1	2	3	4	5		
1-1	337-1399-04			2	SHIELD,ELEC:SIDE					80009	337-1399-04
-2	366-1168-00			1	KNOB:BLACK CAP AND RED BODY					80009	366-1168-00
	213-0153-00			1	.SETSCREW:5-40 X 0.125,STL BK OXD,HEX					000CY	ORD BY DESCR
-3	366-1346-02			1	KNOB:RED					80009	366-1346-00
	213-0153-00			1	.SETSCREW:5-40 X 0.125,STL BK OXD,HEX					000CY	ORD BY DESCR
-4	366-1567-00			1	KNOB:GRY,0.252 ID,0.72 OD,0.79 H					80009	366-1567-00
	213-0153-00			2	.SETSCREW:5-40 X 0.125,STL BK OXD,HEX					000CY	ORD BY DESCR
-5	366-1521-00			1	KNOB:GY,VOLTS/DIV,0.252 ID X 1.1					80009	366-1521-00
	213-0153-00			2	.SETSCREW:5-40 X 0.125,STL BK OXD,HEX					000CY	ORD BY DESCR
-6	366-0494-00			1	KNOB:GRAY WITH SETSCREW					80009	366-0494-00
	213-0153-00			1	.SETSCREW:5-40 X 0.125,STL BK OXD,HEX					000CY	ORD BY DESCR
-7	366-0215-02			1	KNOB:LEVER SWITCH					80009	366-0215-02
-8	366-1690-00			1	KNOB:SIL GY,0.53 X 0.23 X 1.059					80009	366-1690-00
-9	131-1315-01			2	CONN,RCPT,ELEC:BNC,FEMALE					24931	28JR 306-1
-10	342-0117-00			2	INSULATOR,BSHG:0.375 ID X 0.065 L,DELTRIN					80009	342-0117-00
-11	119-0238-00			1	COIL,CAL: ***** (ATTACHING PARTS) *****					80009	119-0238-00
-12	210-0442-00			2	NUT,PLAIN,HEX.:3-48 X 0.187 INCH,CD PL BRS					73743	3014-402
-13	210-0004-00			2	WASHER,LOCK:#4 INTL,0.015 THK,STL CD PL					000BK	ORD BY DESCR
-14	210-0994-00			2	WASHER,FLAT:0.125 ID X 0.25" OD,STL					86928	5702-201-20
-15	210-0849-00			2	WSHR,SHOULDERED:0.11 ID X 0.188"OD,FIBER					83330	2151
-16	210-0593-00			2	NUT,FINISHING:0.25 HEX X 0.312" LONG,BRS ***** (END ATTACHING PARTS) *****					80009	210-0593-00
-17	361-0059-01			1	INSULATOR,PLATE:1.093 X 0.343 X 0.125 INC					80009	361-0059-01
-18	358-0414-00			2	BUSHING,SLEEVE:0.25 OD X 0.21 INCH LONG					80009	358-0414-00
-19	358-0378-00			2	BUSHING,SLEEVE:0.131 ID X 0.125 L					80009	358-0378-00
-20	-----			1	RES.,VAR,NONWIR:(SEE R785 REPL) ***** (ATTACHING PARTS) *****						
-21	210-0583-00			1	NUT,PLAIN,HEX:0.25-32 X 0.312 INCH,BRS					73743	2X20317-402
-22	210-0940-00			1	WASHER,FLAT:0.25 ID X 0.375 INCH OD,STL ***** (END ATTACHING PARTS) *****					79807	ORD BY DESCR
-23	-----			1	CKT BOARD ASSY:FAST RISE(SEE A3 REPL) ***** (ATTACHING PARTS) *****						
-24	220-0497-00			2	NUT,PLAIN,HEX.:0.5-28 X 0.562 INCH HEX,BRS					73743	ORD BY DESCR
-25	210-0406-00			1	NUT,PLAIN,HEX.:4-40 X 0.188 INCH,BRS					73743	12161-50
-26	211-0109-00			1	SCREW,MACHINE:4-40 X 0.875"100 DEG,FLH ST					83385	ORD BY DESCR
-27	361-0682-00			1	SPACER,SLEEVE:0.648 X 0.189 BRS ***** (END ATTACHING PARTS) *****					80009	361-0682-00
	-----			-	CKT BOARD ASSY INCLUDES:						
-28	131-1727-00			2	.CONNECTOR,RCPT,,:BNC,FEMALE					24931	28JR262-1
-29	131-0608-00			9	.TERMINAL,PIN:0.365 L X 0.025 PH BRZ GOLD					22526	47357
-30	333-1863-00			1	PANEL,FRONT: ***** (ATTACHING PARTS) *****					80009	333-1863-00
-31	210-0405-00			2	NUT,PLAIN,HEX.:2-56 X 0.188 INCH,BRS					73743	12157-50
-32	210-0001-00			2	WASHER,LOCK:INTL,0.092 ID X 0.18"OD,ST					78189	1202-00-00-0541C
-33	211-0034-00			2	SCREW,MACHINE:2-56 X 0.50 INCH,PNH ***** (END ATTACHING PARTS) *****					83385	ORD BY DESCR
-34	352-0157-00			1	LAMPHOLDER:WHITE PLASTIC					80009	352-0157-00
-35	200-0935-00			1	BASE,LAMPHOLDER:0.29 OD X 0.19 CASE					80009	200-0935-00
-36	378-0602-03			1	LENS,LIGHT:BLUE					80009	378-0602-03
-37	105-0719-00			1	LATCH,RETAINING:PLUG-IN ***** (ATTACHING PARTS) *****					80009	105-0719-00
-38	213-0254-00			1	SCREW,TPG,TF:2-32 X 0.250,100 DEG,FLH ***** (END ATTACHING PARTS) *****					45722	ORD BY DESCR
-39	105-0718-01			1	BAR,LATCH RLSE:					80009	105-0718-01
-40	386-2843-00			1	SUBPANEL,FRONT: ***** (ATTACHING PARTS) *****					80009	386-2843-00
-41	213-0123-00			4	SCREW,TPG,TF:6-32 X 0.375,SPCL TYPE,FLH ***** (END ATTACHING PARTS) *****					93907	ORD BY DESCR
-42	378-0742-00			1	LENS,LIGHT:CLEAR					80009	378-0742-00
-43	337-1955-00			1	SHIELD,ELEC:REAR SUBPANEL					80009	337-1955-00
-44	-----			1	CKT BOARD ASSY:DISPLAY(SEE A4 REPL)						
-45	-----			2	.LAMP,LED:(SEE DS480,DS482 REPL)						
-46	136-0252-04			4	.SOCKET,PIN TERM:U/W 0.016-0.018 DIA PINS					22526	75060-007
-47	131-0608-00			19	.TERMINAL,PIN:0.365 L X 0.025 PH BRZ GOLD					22526	47357

Replaceable Mechanical Parts—PG 506 (SN B040000 -Up)

Fig. & Index No.	Tektronix Part No.	Serial/Model No. Eff	Dscont	Qty	1	2	3	4	5	Name & Description	Mfr Code	Mfr Part Number
1-48	----			1						CKT BOARD ASSY:DVM/PERIOD(SEE A2 REPL) ***** (ATTACHING PARTS) *****		
-49	211-0292-00			10						SCR,ASSEM WSHR:4-40 X 0.29,BRS NI PL ***** (END ATTACHING PARTS) *****	78189	ORD BY DESCR
	----			-						CKT BOARD ASSY INCLUDES:		
-50	136-0252-04			13						.SOCKET,PIN TERM:U/W 0.016-0.018 DIA PINS	22526	75060-007
-51	----			1						.SWITCH,SLIDE:(SEE S660 REPL)		
-52	175-0825-00			FT						.WIRE,ELECTRICAL:2 WIRE RIBBON	80009	175-0825-00
-53	352-0169-07			1						.CONN BODY,PL,EL:2 WIRE PURPLE	80009	352-0169-07
-54	131-0566-00			3						.BUS CONDUCTOR:DUMMY RES,2.375,22 AWG	57668	JWW-0200E0
-55	131-0608-00			46						.TERMINAL,PIN:0.365 L X 0.025 PH BRZ GOLD	22526	47357
-56	131-1003-00			1						.CONN,RCPT,ELEC:CKT BD MT,3 PRONG	80009	131-1003-00
-57	136-0514-00	B040000	B047326	3						.SKT,PL-IN ELEC:MICROCIRCUIT,8 DIP	73803	CS9002-8
	136-0727-00	B047327		2						.SKT,PL-IN ELEC:MICROCKT,8 CONTACT	09922	DILB8P-108
-58	136-0269-02	B040000	B047326	7						.SKT,PL-IN ELEC:MICROCIRCUIT,14 DIP,LOW CL	73803	CS9002-14
	136-0728-00	B047327		2						.SKT,PL-IN ELEC:MICROCKT,14 CONTACT	09922	DILB14P-108
-59	136-0260-02	B040000	B047326	4						.SKT,PL-IN ELEC:MICROCIRCUIT,16 DIP,LOW CL	71785	133-51-92-008
-60	131-0604-00			10						.CONTACT,ELEC:CKT BD SW,SPR,CU BE	80009	131-0604-00
-61	----			1						CKT BOARD ASSY:RELAY(SEE A5 REPL) ***** (ATTACHING PARTS) *****		
-62	213-0336-00			2						SCR,TPG,THD FOR:6-32 X 1.25 INCH,PNH STL	000BK	ORD BY DESCR
-63	210-0921-00			1						WASHER,MICA:0.50 X 0.141 X0.005 INCH TH	80009	210-0921-00
-64	361-0516-00			2						SPACER,SLEEVE:0.189 OD X 0.986" LONG BRS ***** (END ATTACHING PARTS) *****	80009	361-0516-00
	----			-						CKT BOARD ASSY INCLUDES:		
-65	131-0608-00			26						.TERMINAL,PIN:0.365 L X 0.025 PH BRZ GOLD	22526	47357
-66	131-0566-00			2						.BUS CONDUCTOR:DUMMY RES,2.375,22 AWG	57668	JWW-0200E0
-67	----			1						CKT BOARD ASSY:MAIN (SEE A1 REPL) ***** (ATTACHING PARTS) *****		
-68	213-0146-00			2						SCR,TPG,THD FOR:6-20 X 0.313 INCH,PNH STL	83385	ORD BY DESCR
-69	211-0105-00			1						SCREW,MACHINE:4-40 X 0.188,100 DEG,FLH ST ***** (END ATTACHING PARTS) *****	83385	ORD BY DESCR
	----			-						CKT BOARD ASSY INCLUDES:		
-70	384-1105-00			1						.EXTENSION SHAFT:8.241 L X 0.081 INCH OD	80009	384-1105-00
-71	376-0050-00			1						.CPLG,SHAFT,FLEX:FOR 0.081/0.125 INCH SHAF .SW CAM ACTR ASY:(SEE S610 REPL) ***** (ATTACHING PARTS) *****	80009	376-0050-00
-72	211-0292-00			4						SCR,ASSEM WSHR:4-40 X 0.29,BRS NI PL ***** (END ATTACHING PARTS) *****	78189	ORD BY DESCR
	----			-						.ACTUATOR ASSY INCLUDES:		
-73	210-0406-00			4						..NUT,PLAIN,HEX.:4-40 X 0.188 INCH,BRS	73743	12161-50
-74	401-0115-00			1						..BEARING,CAM SW:CENTER	80009	401-0115-00
-75	105-0631-00			1						..ACTUATOR,CAM SW:PERIOD ***** (ATTACHING PARTS) *****	80009	105-0631-00
-76	354-0391-00			1						..RING,RETAINING:0.395" FREE ID X 0.025" S ***** (END ATTACHING PARTS) *****	97464	3100-43-CD
-77	210-0406-00			4						..NUT,PLAIN,HEX.:4-40 X 0.188 INCH,BRS	73743	12161-50
-78	214-1139-02			2						..SPRING,FLAT:GREEN COLORED	80009	214-1139-02
-79	214-1127-00			1						..ROLLER,DETENT:0.125 DIA X 0.125,SST	80009	214-1127-00
-80	401-0081-02			1						..BEARING,CAM SW:FRONT	80009	401-0081-02
-81	384-1323-00			1						.EXTENSION SHAFT:6.4 L X 0.081 OD SST	80009	384-1323-00
-82	214-1190-02			1						.CPLG,SHAFT,RGD:0.125 OD TO 0.081 OD,AL	80009	214-1190-02
-83	214-1136-00			1						.ACTUATOR,SL SW:DUAL DPST .SW CAM ACTR AS:(SEE S180 REPL) ***** (ATTACHING PARTS) *****	80009	214-1136-00
-84	211-0292-00			4						SCR,ASSEM WSHR:4-40 X 0.29,BRS NI PL	78189	ORD BY DESCR
-85	211-0292-00			2						SCR,ASSEM WSHR:4-40 X 0.29,BRS NI PL ***** (END ATTACHING PARTS) *****	78189	ORD BY DESCR
	----			-						.ACTUATOR ASSY INCLUDES:		
-86	105-0243-00			1						..ACTUATOR,SWITCH:AC,DC ***** (ATTACHING PARTS) *****	80009	105-0243-00
-87	213-0214-00			1						..SCREW,CAP SCH:2-56 X 0.375" HEX HD STL ***** (END ATTACHING PARTS) *****	70278	ORD BY DESCR
-88	131-1314-00			1						..CONTACT,ELEC:GROUNDING	80009	131-1314-00
-89	210-0406-00			3						..NUT,PLAIN,HEX.:4-40 X 0.188 INCH,BRS	73743	12161-50

Fig. & Index No.	Tektronix Part No.	Serial/Model No.		Qty	Name & Description					Mfr Code	Mfr Part Number
		Eff	Dscont		1	2	3	4	5		
1-90	131-0963-00			1	..CONTACT,ELEC:GROUNDING					000EX	OBD
-91	214-1139-02			1	..SPRING,FLAT:GREEN COLORED					80009	214-1139-02
	214-1139-03			1	..SPRING,FLAT:RED COLORED					80009	214-1139-03
-92	214-1127-00			2	..ROLLER,DETENT:0.125 DIA X 0.125,SST					80009	214-1127-00
-93	401-0081-02			1	..BEARING,CAM SW:FRONT					80009	401-0081-02
				(ATTACHING PARTS).....						
-94	354-0391-00			1	..RING,RETAINING:0.395"FREE ID X 0.025" S					97464	3100-43-CD
				(END ATTACHING PARTS).....						
-95	105-0632-01			1	..ACTUATOR,CAM SW:MODE					80009	105-0632-01
-96	210-0406-00			4	..NUT,PLAIN,HEX.:4-40 X 0.188 INCH,BRS					73743	12161-50
-97	401-0115-00			1	..BEARING,CAM SW:CENTER					80009	401-0115-00
-98	105-0634-02			1	..ACTUATOR,CAM SW:AMPL,REAR					80009	105-0634-02
				(ATTACHING PARTS).....						
-99	354-0391-00			1	..RING,RETAINING:0.395"FREE ID X 0.025" S					97464	3100-43-CD
				(END ATTACHING PARTS).....						
-100	105-0482-00			1	..STOP,DETENT:					80009	105-0482-00
-101	210-0406-00			4	..NUT,PLAIN,HEX.:4-40 X 0.188 INCH,BRS					73743	12161-50
-102	214-1139-02			1	..SPRING,FLAT:GREEN COLORED					80009	214-1139-02
	214-1139-03			1	..SPRING,FLAT:RED COLORED					80009	214-1139-03
-103	214-1127-00			2	..ROLLER,DETENT:0.125 DIA X 0.125,SST					80009	214-1127-00
-104	401-0081-02			1	..BEARING,CAM SW:FRONT					80009	401-0081-02
-105	214-2569-00			1	..HEAT SINK,XSTR:(1) TO-5,BE-CU					80009	214-2569-00
-106	131-1031-00			16	..CONTACT ASSY,EL:CAM SWITCH,TOP					80009	131-1031-00
				(ATTACHING PARTS).....						
-107	210-0779-00			16	..RIVET,TUBULAR:0.051 OD X 0.115 INCH LONG					42838	RA-29952715
				(END ATTACHING PARTS).....						
-108	131-1030-00			17	..CONT ASSY,ELEC:CAM SWITCH,BOTTOM					80009	131-1030-00
-109	131-0604-00			10	..CONTACT,ELEC:CKT BD SW,SPR,CU BE					80009	131-0604-00
-110	214-0579-00			6	..TERM,TEST POINT:BRS CD PL					80009	214-0579-00
-111	344-0154-00			4	..CLIP,ELECTRICAL:FUSE,CKT BD MT					80009	344-0154-00
-112	-----			1	..RES.,VAR,NONWIR:(SEE R225 REPL)						
-113	361-0515-00			2	..SPACER,SWITCH:PLASTIC					80009	361-0515-00
-114	-----			1	..RES.,VAR,NONWIR:(SEE R590 REPL)						
				(ATTACHING PARTS).....						
-115	210-0583-00			1	..NUT,PLAIN,HEX:0.25-32 X 0.312 INCH,BRS					73743	2X20317-402
-116	210-0046-00			1	..WASHER,LOCK:0.261 ID,INTL,0.018 THK,BRS					78189	1214-05-00-0541C
				(END ATTACHING PARTS).....						
-117	407-1393-00			1	..BRACKET,ANGLE:BRASS					80009	407-1393-00
-118	351-0180-00			1	..SLIDE,GUIDE:SWITCH ACTUATOR					80009	351-0180-00
-119	131-1003-00			1	..CONN,RCPT,ELEC:CKT BD MT,3 PRONG					80009	131-1003-00
-120	136-0269-02	B040000	B047326	1	..SKT,PL-IN ELEK:MICROCIRCUIT,14 DIP,LOW C					73803	CS9002-14
	136-0728-00	B047327		1	..SKT,PL-IN ELEK:MICROCKT,14 CONTACT					09922	DILB14P-108
-121	136-0514-00	B040000	B047326	6	..SKT,PL-IN ELEK:MICROCIRCUIT,8 DIP					73803	CS9002-8
	136-0727-00	B047327		4	..SKT,PL-IN ELEK:MICROCKT,8 CONTACT					09922	DILB8P-108
-122	131-0566-00			1	..BUS CONDUCTOR:DUMMY RES,2.375,22 AWG					57668	JWW-0200E0
-123	214-1254-00			1	..HEAT SINK,ELEC:0.422 H X 1.240 INCH OD					05820	209SB
-124	342-0324-00			3	..INSULATOR,DISC:TO-5 TRANSISTOR					13103	7717-5N-BLUE
-125	136-0252-07			1	..SOCKET,PIN CONN:W/O DIMPLE					22526	75060-012
-126	131-0608-00			29	..TERMINAL,PIN:0.365 L X 0.025 PH BRZ GOLD					22526	47357
-127	214-1291-00			1	..HEAT SINK,ELEC:XSTR,0.72 OD X 0.375"H					05820	207SB
-128	-----			1	..TRANSISTOR:(SEE Q325 REPL)						
				(ATTACHING PARTS).....						
-129	211-0097-00			1	..SCREW,MACHINE:4-40 X 0.312 INCH,PNH STL					83385	ORD BY DESCR
	210-1178-00	B046760		1	..WASHER,SHLDR:U/W TO-220 TRANSISTOR					49671	DF137A
-130	210-0406-00			1	..NUT,PLAIN,HEX.:4-40 X 0.188 INCH,BRS					73743	12161-50
				(END ATTACHING PARTS).....						
	342-0355-00	B046760		1	..INSULATOR,PLATE:TRANSISTOR,SILICONE RUBB					000BB	7403-09FR-51
	175-3535-00			1	..CABLE ASSY,RF:50 OHM COAX,5.5 L,9-2					80009	175-3535-00
	352-0169-06			1	..CONN BODY,PL,EL:2 WIRE BLUE					80009	352-0169-06
	175-3536-00			1	..CABLE ASSY,RF:50 OHM COAX,7.0 L,9-5					80009	175-3536-00
	352-0169-05			1	..CONN BODY,PL,EL:2 WIRE GREEN					80009	352-0169-05
	198-4323-00			1	..WIRE SET,ELEC:					80009	198-4323-00
	352-0169-02			1	..CONN BODY,PL,EL:2 WIRE RED					80009	352-0169-02
-131	386-3657-01			2	SUPPORT,PLUG IN:					93907	OBD
-132	210-1270-00			2	WASHER,FLAT:0.141 ID X 0.04 THK,AL					80009	210-1270-00

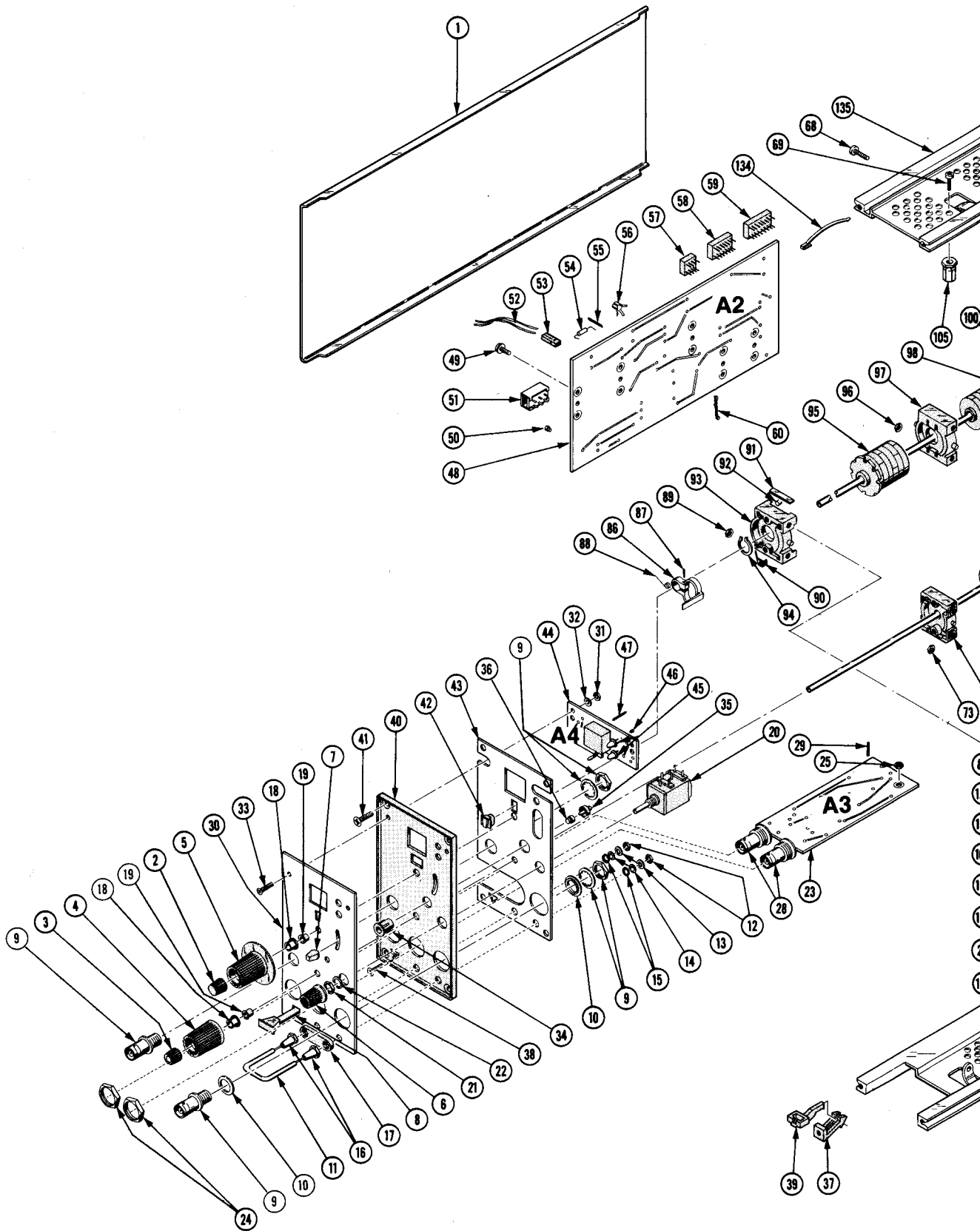

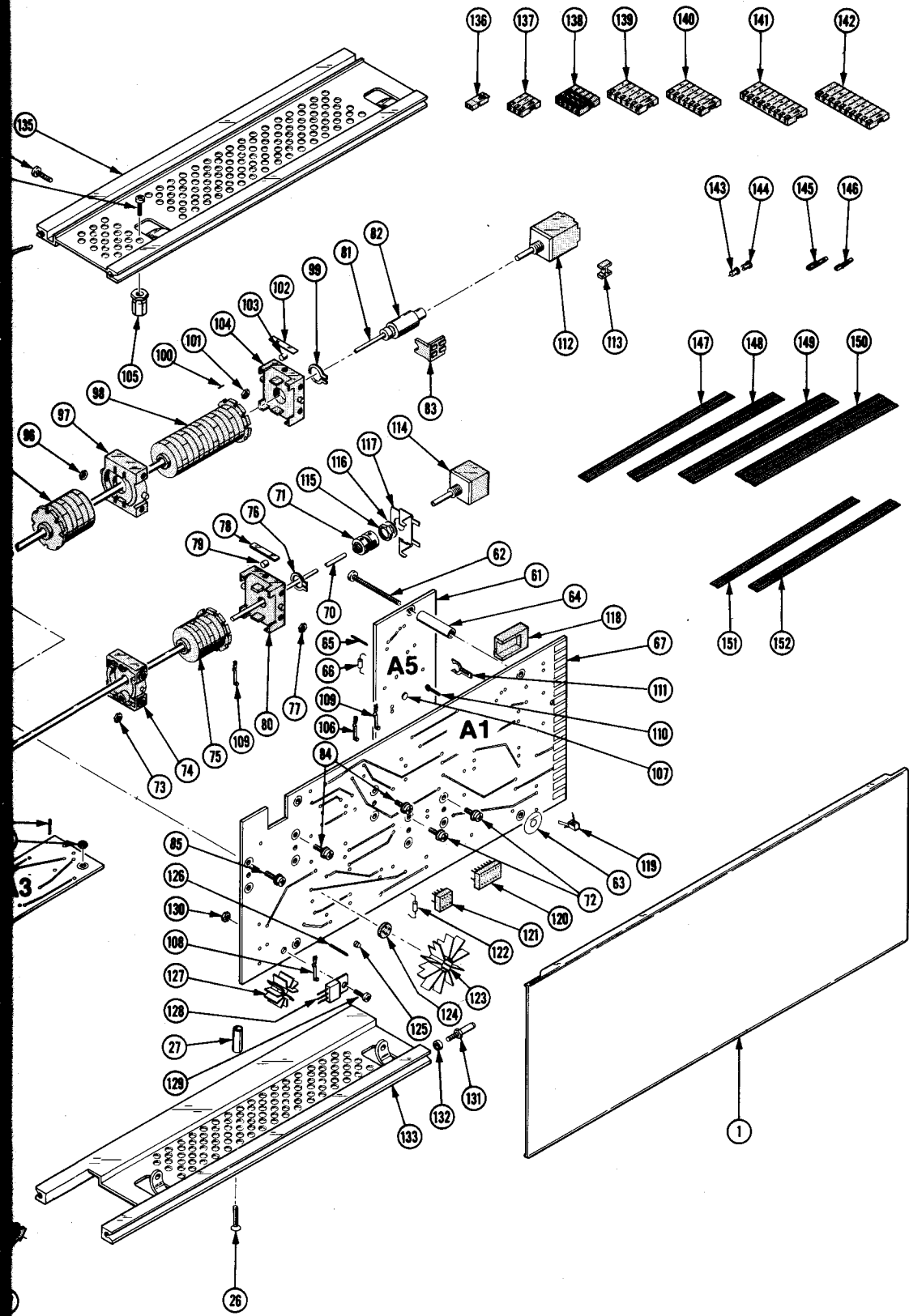

Fig. & Index No.	Tektronix Part No.	Serial/Model No. Eff Dscont	Qty	1	2	3	4	5	Name & Description	Mfr Code	Mfr Part Number
ACCESSORIES											
	070-3383-00		1						MANUAL, TECH:	80009	070-3383-00
	012-0482-00		1						CABLE ASSY, RF: 50 OHM, 36 INCH LONG	80009	012-0482-00

ACCESSORIES

@

PG 506 SNB040000 & UP

MANUAL CHANGE INFORMATION

At Tektronix, we continually strive to keep up with latest electronic developments by adding circuit and component improvements to our instruments as soon as they are developed and tested.

Sometimes, due to printing and shipping requirements, we can't get these changes immediately into printed manuals. Hence, your manual may contain new change information on following pages.

A single change may affect several sections. Since the change information sheets are carried in the manual until all changes are permanently entered, some duplication may occur. If no such change pages appear following this page, your manual is correct as printed.

Date: 6-6-83Change Reference: M44725 REVProduct: PG506 Calibration GeneratorManual Part No.: 070-3383-00

DESCRIPTION

PG 75

Effective Serial Number: B057990

Change to:

A1	670-3230-09	CKT BOARD ASSY: MAIN
A2	670-3234-06	CKT BOARD ASSY: DVM/PERIOD
A4	670-3314-01	CKT BOARD ASSY: DISPLAY
R650	315-0621-00	RES,FXD,CMPSN:620 OHM, 5%, 0.25W
R705	315-0621-00	RES,FXD,CMPSN:620 OHM, 5%, 0.25W
DS650, DS704	150-1036-00	LAMP,LT. EMITTING DIO,RED,650NM,40MA Max
DS700	150-1011-02	LAMP,LED,RDOUT: RED,7SEG,1.0 DIGIT
DS702	150-1011-02	LAMP,LED,RDOUT: RED,7SEG,1.0 DIGIT
R785	311-2214-00	RES,VAR,NON WW,PANEL: 5K OHM,20%,0,5W
S180A,B	263-1098-04	ACTR ASSY, CAM S: MODE/AMPLITUDE

Refer to the Replaceable Mechanical Parts for the following:

Fig.

1-1	337-3039-00	SHIELD,ELEC: SIDE
1-3	366-1711-02	KNOB: RED
1-4	366-2081-00	KNOB: GRY,0.252 ID,0.72,0.79 H
1-5	366-2082-00	KNOB: GY,VOLTS/DIV
1-6	366-0494-05	KNOB: GRAY W/SET SCREW
1-7	366-0215-05	KNOB: LEVER SWITCH
1-8	366-1815-01	KNOB,LATCH: SIL GY
1-37	105-0866-00	LATCH,RETAINING:PLUG-IN
1-39	105-0865-00	BAR LATCH, RELEASE
1-41	(1) 211-0025-00	SCREW,4-40 X 0.312 L
	(3) 211-0101-00	SCREW,4-40 X 0.250 L
1-43	337-3075-00	SHIELD,ELECT: FRONT SUB-PANEL
1-80	384-1066-00	EXTENSION SHAFT: 6.1 L X 0.081 OD SST
1-97	105-0634-03	ACTUATOR,CAM SW:AMPL,REAR
1-133	426-0724-25	FRAME SECT: BOTTOM
1-134	214-3406-00	SPRING,GND:FLAT
1-135	426-0725-24	FRAME SECT: TOP

Date: 7-29-83

Change Reference: M44725 Addendum

Product: PG506 Calibration Generator

Manual Part No.: 070-3383-00

DESCRIPTION

PG 75

Effective Serial Number: B057990

ADD:

2	105-0932-00	LATCH, PANEL: SIDE
2	210-0845-00	WASHER, FLAT: 0.5ID, 0.625 OD
1	210-1258-00	WASHER, FLAT: 0.265ID, 0.375 OD
2	211-0244-00	SCR,ASSEM,WSHR: 4-40 x 0.312 PNH
2	213-0793-00	SCREW,TPG,TF: 6-32 x 0.4375
1	214-3143-00	SPRING, HLEXT: 0.125 OD x 0.545 L
2	214-3364-00	FASTNER, LATCH: ACETAL, SIL GRAY
1	333-3050-00	PANEL, FRONT: PG506
1	378-2030-06	LENS, LED DSPL: RED, PRINTED PG506
1	386-4866-00	SUPPORT, FRAME: REAR,AL

Date: 11-10-83

Change Reference: M52846

Product: PG506 CALIBRATION GENERATOR

Manual Part No.: 070-3383-00

DESCRIPTION PG 75

EFFECTIVE SERIAL NUMBER: B058180

CHANGE TO:

A1	670-3230-10	CKT BOARD ASSY: MAIN
C20	283-0179-00	CAP., FXD, CER DI: .68uF, 10%, 100V

Date: 5-1-84

Change Reference: M50403

Product: PG506 CALIBRATION GENERATOR (B040000 & UP)

Manual Part No.: 070-3383-00

DESCRIPTION

PG 75

Effective Serial B058400:

ELECTRICAL PARTS LIST and SCHEMATIC CHANGES

CHANGE TO:

A6	670-3230-12	CKT BOARD ASSY: MAIN
R315	321-0306-00	RES., FXD, FILM: 15K OHM, 1%, 0.125W
R787	315-0202-00	RES., FXD, CMPSN: 2K OHM, 5%, 0.25W
U20	156-0071-03	MICROCIRCUIT, LI: VOLTAGE REGULATOR