

# Phase Matrix, Inc. EIP 545B and 548B CW Frequency Counters

**Full Function CW Microwave  
Frequency Counters with  
Selective Power  
Measurement**



- Keyboard controlled frequency limit selection
- Power Measurement to 0.1 dB resolution
- Power Measurement accuracy to  $\pm 0.5$  dB typical
- -30 dBm sensitivity
- 200 Watt (+53 dBm) peak damage protection
- 10 dB automatic amplitude discrimination
- 200msec acquisition time
- Up to 800 MHz/sec tracking speed
- 20MHz P-P FM tolerance up to a 10 MHz rate

# Phase Matrix / EIP 545B and 548B. . . .

## Full Function Microwave Frequency Counters

### The Ideal Benchtop Counters

The combination of accuracy, simple operation, and the widest range of standard features and options available in a microwave counter makes the 545B/548B family the best choice for your R&D lab or production test bench. Wherever a microwave counter has multiple duties and a variety of applications to meet, only a full function counter with YIG-tuned preselection can provide the capabilities that you need.

The 545B measures CW, FM and AM frequencies from 10 Hz to 20 GHz, and the 548B extends that range up to 26.5 GHz. With simultaneous power measurement capability, and options for a high stability time base, these high performance counters are ideally suited for applications in:

- Carrier signal measurement
- Transmitter frequency verification
- Channel specific signal measurements
- Production Line testing
- R&D Labs
- ATE

### Unsurpassed Burnout Protection

Typically found in high performance spectrum analyzers; only Phase Matrix counters feature a YIG-preselected microwave input, which provides unparalleled burnout protection, FM tolerance and frequency selectivity. The YIG preselector works like a tunable bandpass filter, preventing harmonics and other out-of-band spurious signals from interfering with measurement of the desired signal. It also protects the counter from accidental application of high level signals (up to 200 watts peak), reducing downtime and the associated high cost of repairing damaged microwave circuitry.

### Selective Frequency and Power Measurements

With a single connection, the 545B and 548B can simultaneously measure and display the input signals frequency and power level in the microwave band, eliminating the need for a separate microwave power meter. Within the 25MHz bandwidth of the YIG-preselector, only the selected signals frequency and power level are measured. Signals to be analyzed are selected by keystroke entry of an individual center frequency, or search a range between a low and high frequency limit. This signal selectivity, combined with 20MHz of FM tolerance at all rates up to 10MHz, allows the 545B and the 548B to make accurate frequency and power level measurements even while the input signal is carrying traffic; there is no need to take the transmitter, or adjacent channels, off the air for routine checks.



*Only Phase Matrix counters offer the unique YIG-preselected heterodyne technique.*

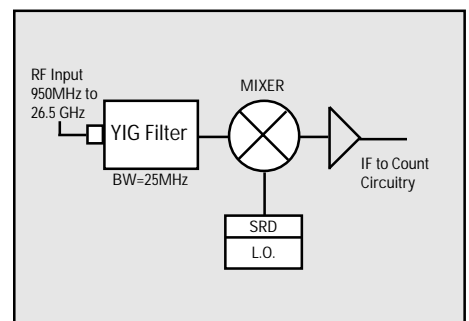

*All Phase Matrix Counters feature the unique YIG Preselected Heterodyne Down-Converter.*

# Phase Matrix / EIP 545B and 548B. . . .

## The Ultimate Benchtop Instrument

### Frequency Extension to 110 GHz

Option 06 provides the ability to extend the frequency range of your 548B, in bands, up to 110 GHz. Remote sensors allow you to reach out to connect to virtually any wave guide system without the complications of the additional plumbing necessary to bring the signal to your counter. A wide selection of sensors provides measurement capability in the wave guide band that you are working in now, and the flexibility to change as your application changes without having to purchase another counter.

### Frequency Limits

Automatic amplitude discrimination enables the 545B/548B counters to automatically select and measure the input signal with the highest level, and ignore all other harmonics and other spurious signals that are present. "Frequency Limits" extend this signal selection capability by allowing you to select upper and lower limits. The counter will measure the frequency and power level of only the highest level signal within these limits - even if there are higher level signals present at the counters input. This gives you the ability to measure the frequency and power of a low level signal (such as a harmonic) even when a signal of much higher level (the fundamental) is present.

### Power Measurement

The 545B/548B family of microwave counters offers the optional ability to simultaneously measure both the frequency and power level through the same input. This often eliminates the need for a separate microwave power meter. With the 25 MHz bandwidth of the YIG tuned preselector, power measurement is made only of the displayed signal, not of its harmonics or other signals present. Thus you can simultaneously measure and display both frequency and power of individual signals in a multisignal environment. Easy keystroke entry of power offsets can be used to measure power deviation from a reference, or to compensate for losses in external hook-ups such as cable and attenuator losses.

### Proven Reliability

This counter has become the standard in reliability, achieving over 26,000 hours (12.5 years) of field-proven MTBF. The high performance, economy and compact configuration of the 545B and 548B make them the ideal choice for your production and R&D applications on the bench.

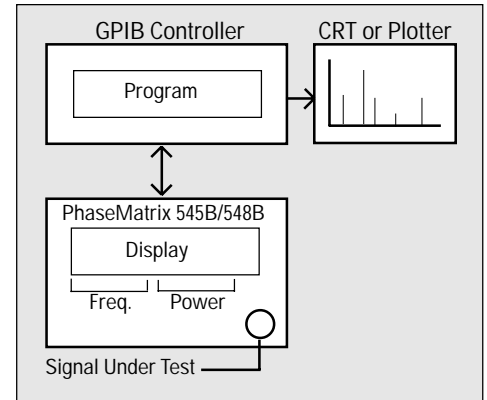

*Frequency domain analysis can be accurately and quickly performed by utilizing the counter's selective frequency and selective power measurement capabilities.*

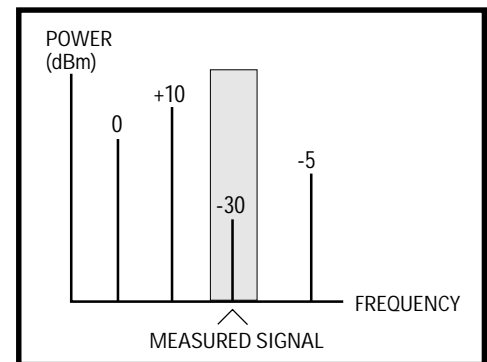

*The frequency selective operation of the counters allows measurement of any individual signal's frequency and power in a multi-signal environment.*

# SPECIFICATIONS

MODEL 545B and 548B	BAND 1	BAND 2	BAND 3
<b>Frequency Range</b>	10 Hz-100 MHz	10 MHz-1 GHz	1-20 GHz (545B) 1-26.5 GHz (548B)
<b>Sensitivity</b>	25mV rms	-20dBm	-30 dBm 1-12.4 GHz -25 dBm 12.4 GHz-20 GHz -20 dBm 20 GHz-26.5 GHz
<b>Impedance</b>	1M $\Omega$ /20pF	50 Ohms	50 Ohms
<b>Connector</b>	BNC (female)	BNC (female)	Precision Type N-female (545B) APC 3.5-female (548B)
<b>Input Coupling</b>	DC	AC	AC
<b>Maximum Operating Level</b>	120 V rms*	+10 dBm	+10 dBm
<b>Damage Level</b>	150 V rms*	+27 dBm	+45 dBm (30 watts) continuous +53 dBm (200 watts) peak pulsed (<1 $\mu$ S PW, 0.1% duty)
<b>Acquisition Time</b>			
Standard	N/A	<50mS	<200ms
Center Frequency Mode	N/A	N/A	<20ms
<b>Automatic Amplitude Discrimination</b>	N/A	N/A	10 dB
<b>FM Tolerance</b>	Carrier remains in band	Carrier remains in band	20 MHz P-P up to 10MHz rate
<b>Maximum Tracking Speed</b>	Carrier remains in band	>800MHz/sec typical	>800MHz/sec typical
<b>VSWR</b>	N/A	2.5:1 typical	2.5:1 typical
<b>Center Frequency Mode</b>	N/A	N/A	Keyboard controlled. Unit will measure signal within $\pm$ 5 MHz of entered frequency. Signals of equal amplitude must be separated by 40 MHz
<b>Frequency Limits</b>	N/A	N/A	Keyboard controlled. Unit will measure largest signal within set limits. Signals outside desired range must be separated by $\geq$ 200 MHz (typical) from either limit.

\*Above 1KHz, decreases @ 6dB/octave down to 3.0 V rms

## BAND 4 (option 06, 548B only)

<b>Frequency Range</b>	26.5 GHz - 110 GHz
<b>Sensitivity</b>	-25 dBm typical
<b>Connector</b>	Depends on remote sensor
<b>Maximum Operating Level</b>	+5 dBm
<b>Damage Level</b>	+10 dBm
<b>Acquisition Time</b>	<1 second typical
<b>Amplitude Discrimination</b>	10 dB

# SPECIFICATIONS

## Power Measurement

---

Frequency Range	1-20 GHz (545B) 1-26.5 GHz (548B)
Accuracy	±1.2 dB typical (0° to 50°C, input padded by 3 dB) ±0.5 dB typical (25°C, input padded by 3 dB)
Resolution	Power: ±0.1 dB Frequency: 100 kHz to 1 GHz (selectable) via GPIB 1 Hz to 1 GHz (selectable) via GPIB
Minimum Level	Equal to counter sensitivity
Display	Simultaneous frequency and power reading
Offset Range	-99.9 dB to +99.9 dB
Offset Resolution	0.1 dB
Offset Input	Keyboard or optional GPIB
Measurement Time	1 Gate Time + 50ms + Freq Measurement Time
Measurement Window	25 MHz nominal

## Time Base: Standard TCXO

---

Crystal Frequency	10 MHz
Stability	Aging Rate <math><1 \times 10^{-7}</math>/month, <math><1 \times 10^{-6}</math>/year Short Term <math><1 \times 10^{-9}</math> rms for one sec. averaging time Temperature <math><1 \times 10^{-6}</math>, 0° to 50°C Line Variation <math><1 \times 10^{-7}</math>, ±10% line voltage
Output Frequency	10 MHz square wave, 1V P-P min into 50Ω
External Time Base	Requires 10 MHz, 1V P-P min into 300Ω

## GPIB (IEEE-488/1978) Programmability

---

GPIB	Functions, special functions and diagnostics are programmable. Address settable from the front panel. Compatible IEEE STD-488. SH1, AH1, T5, L3, SR1, RL1, DC1 and DT1 implimented.
------	---

## General

---

Warranty	1 year Standard (Extendable to 3 years)
Frequency Resolution	Selectable 0.1 Hz to 10 MHz in band 1, 1 Hz to 1 GHz in bands 2 and 3.
Display	12-digit LED sectionalized to read GHz, MHz, kHz, Hz or GHz, MHz, kHz, dBm.
Frequency Accuracy	± 1 count ± time base error.
Test	Front panel selected service diagnostics and user information.
Sample Rate	Varies time between measurements, from 0 sec to 10 sec. HOLD freezes display indefinitely.
Reset	Resets display to zero and initiates new acquisition.
Frequency Offset	Displayed frequency is offset by the entered value to 1 Hz resolution.
Frequency Multiply	Displayed frequency is multiplied by an entered integer from 1 to 99 and displayed to 1 kHz resolution. OFFSET is added or subtracted to obtain $y = mx \pm b$ result.
Computer Interface	GPIB (IEEE 488/1978)
Certifications	CE Certified for EMI/RFI to EN50011 and EN50082-1 Certified for Safety to IEC 1010-1 (1990)
Operating Temperature	0° to 50°C.
Power	100/120/140/200/220/240/VAC ±10%, 50 to 400 Hz; 60 VA typical.
Net Weight	~ 26 lbs. (11.8 kg).
Shipping Weight	~ 32 lbs. (14.5 kg).
Dimensions	3.5" H x 16.75" W x 14.0" D (89 mm H x 425 mm W x 356 mm D).
Standard Accessories	Power cord, Operating manual.

# SPECIFICATIONS

## OPTION 01 Digital to Analog Converter

Option 01 will convert any three consecutively displayed digits to an analog voltage output. A display of 000 produces 0 volts output; 999 produces 0.999 volts full scale. Output is updated after every display update.

## OPTION 02 Power Measurement

Option 02 measures power of signals applied to the Band 3 input. Power and frequency are simultaneously displayed to 0.1 dB and 100kHz resolution, respectively. Option 02 also allows power offsets from -99.99 to +99.99 dB (0.1 dB resolution) to be input from the keyboard or via GPIB.

## OPTION 05 High Stability Ovenized Timebase

### Stability

Aging Rate	<5x10 <sup>-10</sup> /day, (After 24 hour warm up).
Short Term	<1x10 <sup>-10</sup> rms for one sec. averaging time
Temperture	<3x10 <sup>-8</sup> , 0° to 50°C
Line Variation	<2x10 <sup>-10</sup> , ±10% line voltage
Retrace	<5x10 <sup>-9</sup> of final value 10 minutes after counter is turned on at 25°C

## Frequency Extention Accessories

590	Frequency extention cable kit	<b>Note:</b> All remote sensors require cable kit 590 and extended frequency Option 06
091	26.5-40 GHz remote sensor, waveguide	
092	40-60 GHz remote sensor, waveguide	
093	60-90 GHz remote sensor, waveguide	
094	90-110 GHz remote sensor, waveguide	
095	50-75 GHz remote sensor, waveguide	
096	33-50 GHz remote sensor, waveguide	
097	26.5-50 GHz remote sensor, coax	

## ORDERING INFORMATION

<b>MODEL 545B</b>	10 Hz - 20 GHz Microwave Frequency Counter
<b>MODEL 548B</b>	10 Hz - 26.5 GHz Microwave Frequency Counter

### Options

01	Digital to Analog Converter
02	Power Measurement
05	High Stability Ovenized Time Base
06	Frequency Extension
09	Rear Panel Signal Input
10	24" Chasis Slides
14	2 Year Warranty Extension (3 years total)
15	MIL-STD 45662 (ANSI Z540-1:94)

### Accessories

010	Transit Case
020	Rack Mount Kit
031	Extra Operating Manual (one supplied at no cost)
032	Maintenance and Service Manual (includes operation information)
040	Service Kit