

### SERIES 626 UNIVERSAL DISTURBANCE ANALYZER

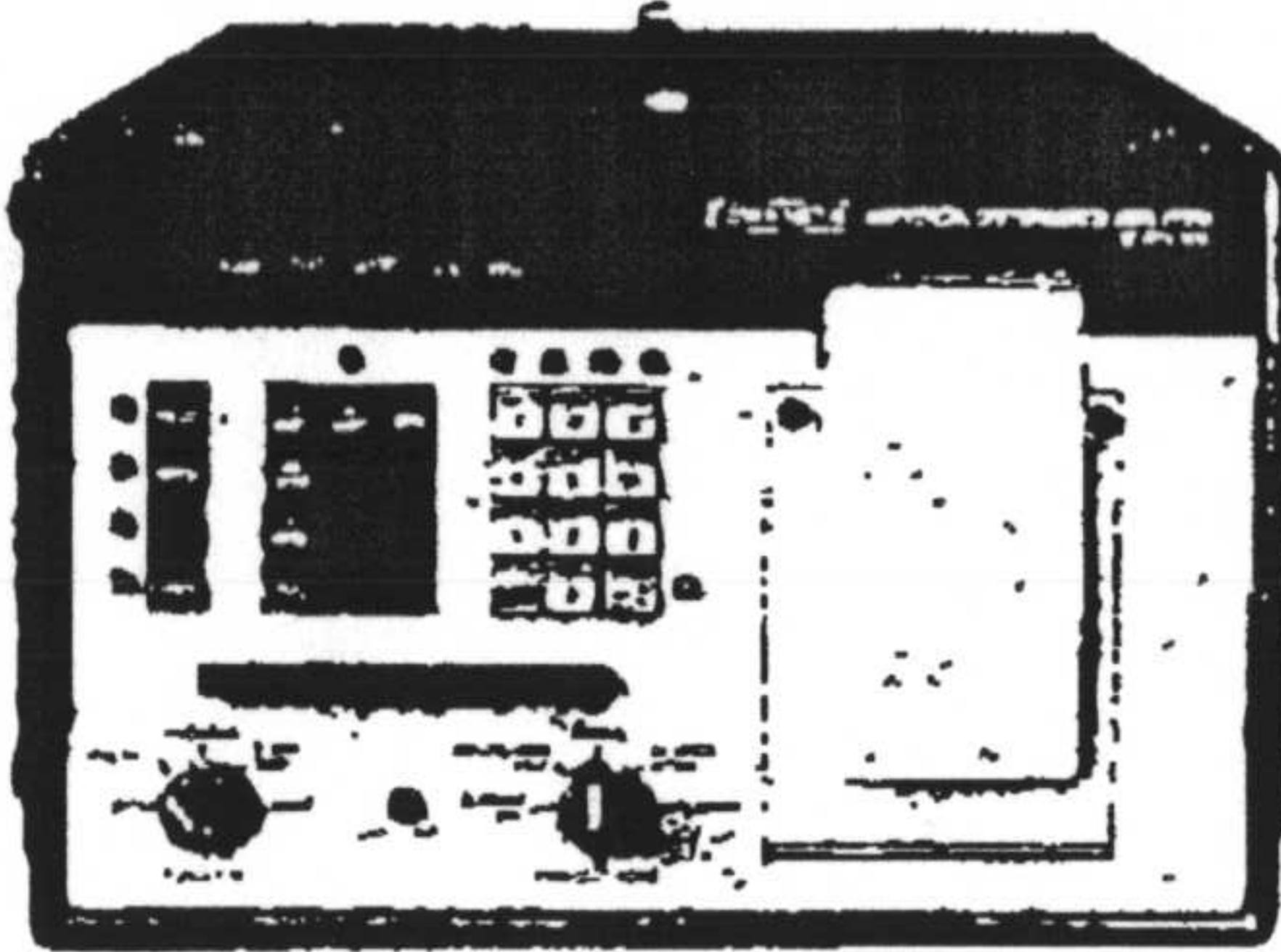

- An expandable system designed for full power line and environmental analysis.
- Monitors sags, surges, undervoltages, overvoltages, frequency variations, and impulse magnitude, polarity, duration, strength and direction.
- Remote monitor feature allows multi-site monitoring at low cost.
- U.L. listed for maximum operator safety.

### SERIES 808 ELECTRIC POWER AND DEMAND ANALYZER

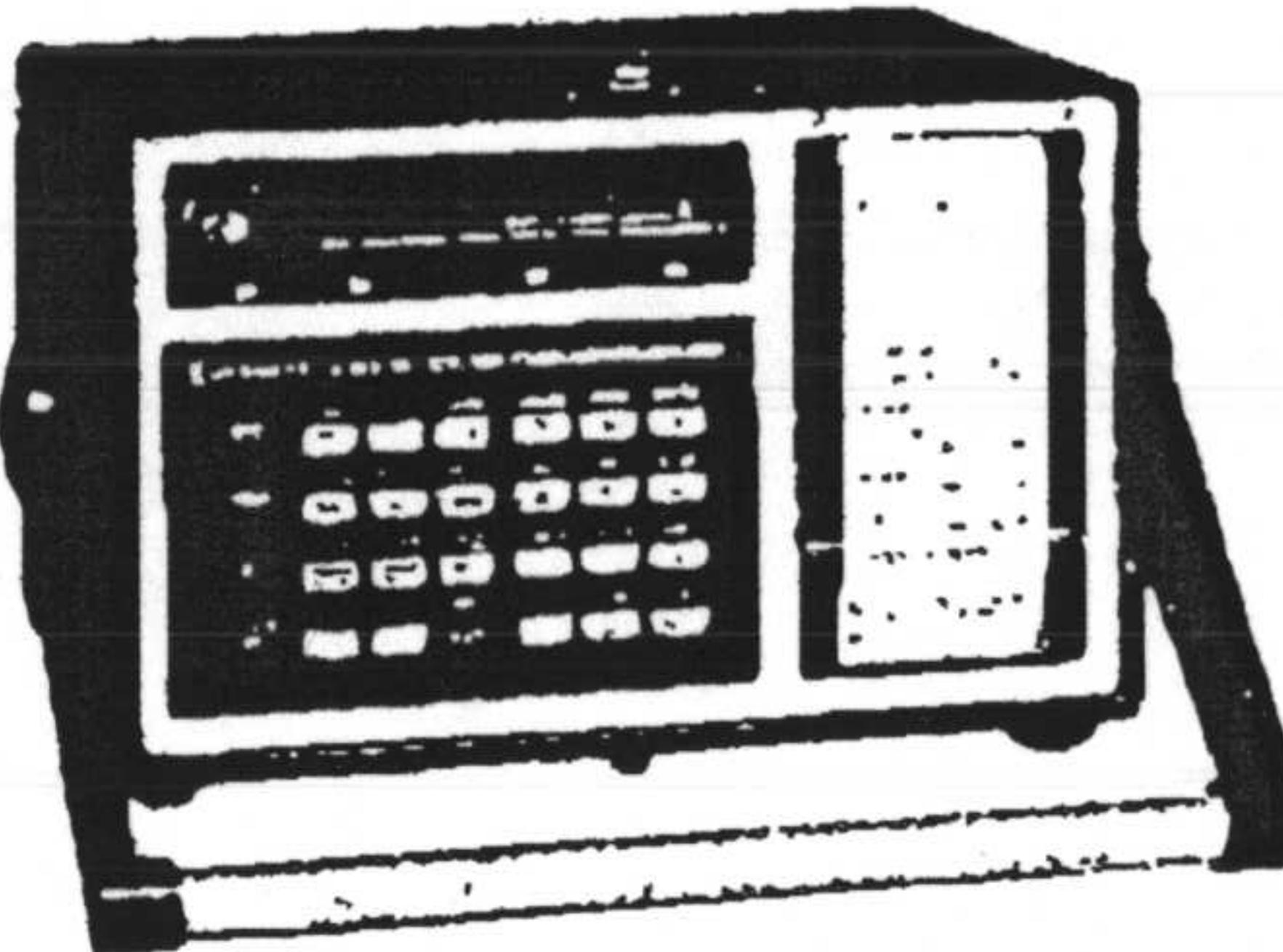

- Provides all measurements needed for reducing electric power costs.
- Displays and prints Volts, Amps, PF, KW, KWH, KVA, KVAR, demand, projected demand, time and date.
- Analyze electric energy and demand usage.
- Develop electrical energy management programs.
- Establish continuous monitoring to maintain efficient energy consumption.
- Submeter plant areas, buildings and equipment.
- Troubleshoot plant power systems for intermittent problems.

## USER'S GUIDE

# POWER LINE DISTURBANCE ANALYZERS

Series 606-1  
Series 606-3  
Series 616 (A, B & C)  
Series 606-PA-600X

**NOTE: DO NOT REMOVE  
THIS GUIDE FROM INSTRUMENT.**

**DRANETZ**  
TECHNOLOGIES, INC.

COMPUTER PRODUCTS DIVISION

1000 New Durham Rd., CN-91  
Edison, New Jersey 08818  
Telephone: (201) 287-3680  
TWX: 710-997-9553  
Telex: 499-7808

**DRANETZ**  
TECHNOLOGIES, INC.

COMPUTER PRODUCTS DIVISION

1000 New Durham Rd., CN-91  
Edison, New Jersey 08818  
Telephone: (201) 287-3680  
TWX: 710-997-9553  
Telex: 499-7808

## STATEMENT OF WARRANTY

All products of Dranetz Technologies, Inc. are warranted to the original purchaser against defective material and workmanship for a period of one year from the date of delivery. Dranetz will repair or replace, at its option, all defective equipment returned to it, freight prepaid, during the warranty period, without charge, provided there is no evidence that the equipment has been mishandled or abused.

**NOTE:** Although the information in this handbook has been carefully checked for accuracy, and is believed to be correct, no warranty, either express or implied, is made as to either its applicability or its compatibility with specific requirements; nor does Dranetz Technologies, Inc. assume any responsibility for correctness of this information, or for damages consequent from its use. All design characteristics, specifications, tolerances, and the like are subject to change without notice. Publication of this information is not intended to convey patent rights, if any. Some of the devices and circuits described herein are covered by U.S. Patent Numbers 3,549,874; 4,187,461; 4,206,413.

This guide is furnished as a quick reference aid for using the Series 606/616 in their most common applications. The User's Guide should, by no means, be considered an effective substitute for carefully reading and understanding the 606 Operator's Manual (TM-102700, Volume 1), the 606-PA-600X Operator's Manual (TM-103161/2/3/4), or the 816 Operator's Manual (TM-103140).

## GENERAL DESCRIPTION

The Series 606/616 is a microprocessor based portable instrument designed to monitor a wide range of AC power line or DC disturbances. Capable of continuous unattended operation, the units store, analyze, classify, and print out quantitative disturbance data. Accompanying the data is a printout of time for correlation with equipment malfunctions. Time is provided by a crystal-controlled 24-hour clock.

The 606-3 contains three independent measurement channels for monitoring up to three voltage inputs whose RMS values may range from 60 to 600 volts depending upon nominal input settings. The Series 616 also has 3 independent channels. Channel A monitors AC voltage (40-250 VAC for 616A, 80-500 VAC for 616B and 616C). Channels B and C monitor DC voltage (4-25 VDC for 616A, 8-50 VDC for 616B, 12-75 VDC for 616C).

Disturbances are classified into three categories: slow average, sag/surge, or impulse. Independent threshold values, which when exceeded initiate a printout, are operator selectable. Except for an automatic summary printout at the end of each day, printout occurs only when disturbances occur or upon operator demand (unless the paper is low or the printer is off).

The Series 606-PA-600X is used as an accessory to the Series 606 with Option 105. It provides the user with impulse strength measurements as well as direction of travel.

## WARNING

Because of shock or fire hazards, connection to this instrument should be performed in compliance with the National Electrical Code (ANSI C1) and/or any other requirements which may be applicable to the user. Installation, operation, and maintenance should be performed only by qualified personnel.

## INITIAL SETUP

### SERIES 606, 616 & 606-PA-600X

#### Initial Setup: Series 606

- A. Verify the voltage to be monitored with a voltmeter and then make the appropriate selection on the nominal input switch before applying power to the 606.

NOTE: Nominal input switch should agree with the voltages actually monitored. For example, in a 208/120 VAC system, either the 230 or 115 volt setting may be appropriate, depending upon how the power is monitored see "Connection Instructions."

- B. Determine what magnitude disturbances (sags/surges/impulses) could cause your equipment to malfunction and make the corresponding settings on the 606.

#### Initial Setup: Series 616

- A. Verify the voltages to be monitored with a voltmeter. Make sure they will fall within the monitoring ranges of the 616 (40-250 VAC and 4-25 VDC for 616A, 80-500 VAC and 8-50 VDC for 616B, 80-500 VAC and 12-75 VDC for 616C).
- B. Make proper selection of thresholds with switches at top of 616.

#### Initial Setup: Series 606-PA-600X

- A. Set up 606 as described above. Make sure threshold switches on 606-PA-600X are at the same settings as 606.
- B. Verify that cable assembly 103099 is installed between 606 and 606-PA-600X, and that a jumper wire is installed between the grounding terminals. Jumpers must also be installed between terminals A1, A2 on 606, and A1, A2 on 606-PA-600X (single phase), and between A1, A2, B1, B2, C1, C2 on 606 and A1, A2, B1, B2, C1, C2 on 606-PA-600X (3 phase).
- C. Refer to diagrams on pages 21-24. Verify proper connections and proper orientation of current probes.

## DEFINITIONS

Brief definitions of the above mentioned disturbances are given below. NOTE: Examples are from 606-3. 606-1 does not indicate channel letter (single channel only). 616 printouts are similar, but indicate DC voltages on channels B and C.

#### SAGS:

Sags are sudden voltage drops which are detected by analyzing each cycle and comparing its RMS level to the slow averaged steady-state value. When the cycle-to-cycle level deviates by more than the pre-selected threshold, a SAG is detected and a cycle count is begun. The lowest voltage reached during the sag along with the time of occurrence are printed on the tape.

EXAMPLE: Sag/Surge set at 3 V  
Last printed AVG = 112V

#### Sample Printout

```
0010 CYCLES  
L 1000 SWG  
0010 CYCLES  
R 1000 SWG  
0009 CYCLES  
A 1000 SWG  
00 04 35  
  
FREQ 060 HZ +  
L 1120 RMS +  
H 1120 RMS +  
R 1120 RMS +  
00 04 35  
  
RESET  
  
M1 HUEPAGE 1120  
C 1120 RMS 00 04 15  
M1 HUEPAGE 1120  
B 1120 RMS 00 04 12  
L0 HUEPAGE 1120  
M1 HUEPAGE 1120  
H 1120 RMS 00 04 06  
M1 FREQ 060 HZ  
FREQ 060 HZ  
RESET 00 00 0000
```

#### EXPLANATION:

All 3 phases sagged at 00:04:35. All 3 phases reached a low of 100 volts. Phase A was below threshold for 9 cycles. Phases B and C stayed low for 10 cycles. (1 cycle = 16.6 milliseconds @ 60 HZ, 20 milliseconds @ 50 HZ).

#### FIGURE 1

(Read Tape Bottom To Top)

### SURGES:

Surges are sudden voltage increases which are detected with the same techniques used to detect sags. A cycle count and the highest voltage reached during the surge are printed together with the time the surge occurred.

**EXAMPLE: Sag/surge set at 5 V**  
Last Printed AVG = 113 V

### Sample Printout:

```

0009 CYCLES
C 123V SURGE
0010 CYCLES
B 123V SURGE
0010 CYCLES
H 123V SURGE
00 06 05

FREQ 060 0HZ +
B 113V AVG +
C 113V AVG +
H 113V AVG +
00 05 56

RESET

LO AVERAGE 112V
HI AVERAGE 113V
C 113V AU 00 05 47
HI AVERAGE 113V
E 113V AU 00 05 44
LO AVERAGE 112V
HI AVERAGE 113V
H 113V AU 00 05 38
HI FREQ 060 0HZ
FREQ 060 0HZ
RESET DAY 00 ACCUM

```

### EXPLANATION:

All 3 phases surged at 00:06:05. All reached a peak voltage of 123 volts. Phase C stayed high for 9 cycles; phases A and B, 10 cycles.

**FIGURE 2**  
(Read Tape Bottom To Top)

### IMPULSE:

A short duration (.5 to 800 microsec.) spike superimposed upon the AC sine wave or DC voltage. The printout is the absolute value of the magnitude of the spike alone, ignoring the AC or DC, as indicated in the illustrations. Note that positive and negative-going impulses are treated identically.

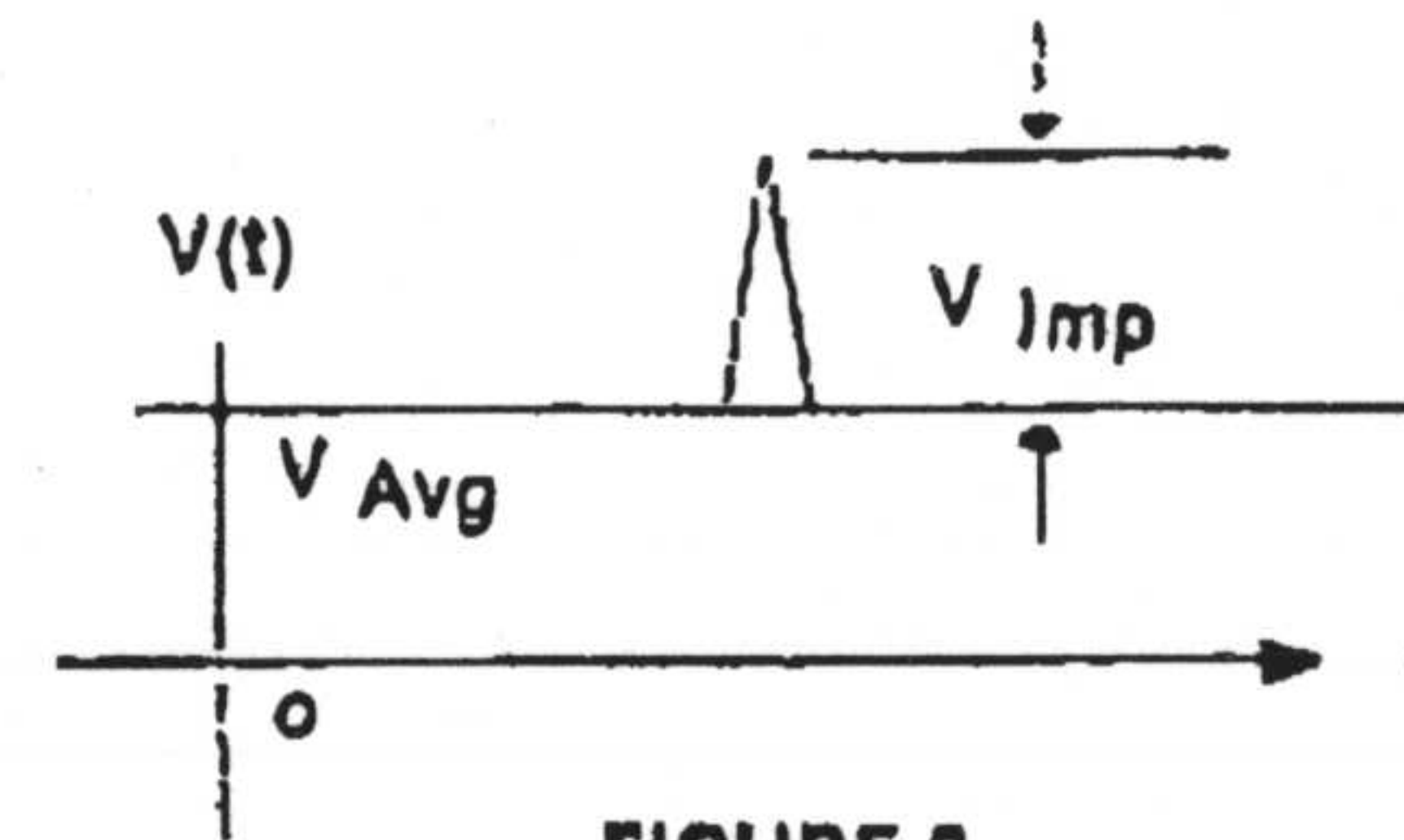
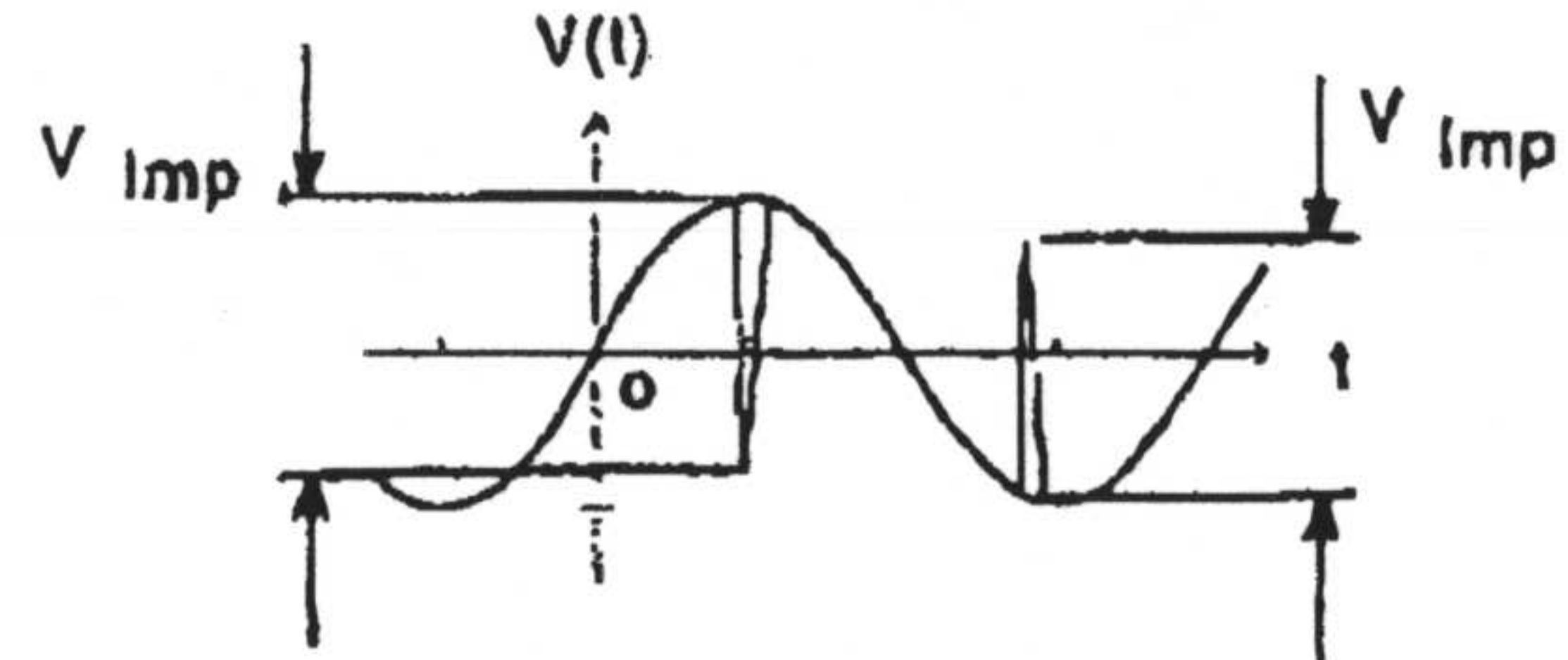

**FIGURE 3**

**EXAMPLE: Impulse threshold at 100 V**

### Sample printout:

```

C 0112V IMPULSE
B 0140V IMPULSE
A 0140V IMPULSE
00:08:53

FREQ 060 2HZ +
C 113V AVG +
A 113V AVG +
B 113V AVG +
00:08:45

RESET

HI AVERAGE 113V
C 113V AU 00:08:38
HI AVERAGE 113V
B 113V AU 00:08:34
HI AVERAGE 113V
A 113V AU 00:08:31
HI FREQ 060 0HZ
FREQ 060 0HZ
RESET DAY 00 ACCUM

```

**EXPLANATION:** Impulses occurred on all 3 phases, with magnitudes as indicated. All 3 impulses occurred at 00:08:53. No assumption can be made regarding exact duration of impulses, their polarity, or their positions on the AC waveform.

**FIGURE 4**  
(Read Tape Bottom To Top)

## DAILY ACCUMULATION

### Sample printout:

```

HI AVERAGE 1130
C 1130 AU 00:00:51
HI AVERAGE 1130
B 1130 AU 00:00:49
HI AVERAGE 1130
A 1130 AU 00:00:44
LO FREQ 059.9HZ
FREQ 059.9HZ
TEST DAY 02 ACCUM
    
```

```

IMP 01120 0005 HTS
SAG 1030 0004 HTS
LO AVERAGE 1120
HI AVERAGE 1130
C 1130 AU 00:00:27
IMP 01400 0003 HTS
SAG 1020 0006 HTS
SUR 1230 0001 HTS
LO AVERAGE 1120
HI AVERAGE 1130
B 1130 AU 00:00:18
IMP 01400 0005 HTS
SAG 1080 0001 HTS
SUR 1200 0001 HTS
LO AVERAGE 1120
HI AVERAGE 1130
A 1130 AU 00:00:05
LO FREQ 060.0HZ
HI FREQ 060.2HZ
FREQ 060.0HZ
DAY 01 ACCUM
    
```

### FIGURE 5

(Read Tape Bottom To Top)

### EXPLANATION:

- 1) Accumulated data for day 01 to be presented.
- 2) Present frequency = 60.0 HZ.
- 3) High frequency for day 01 = 60.2 HZ.
- 4) Low frequency for day 01 = 60.0 HZ.
- 5) Present voltage, channel A, 113 volts, at 00:00:05 (on day 02)
- 6) High average (slow average) for day 01, Channel A, was 113 volts.
- 7) Low average (slow average) for day 01, channel A, was 112 volts.
- 8) Surges: Highest surge, day 01 channel A, 120 volts. A total of 1 surge, day 01.
- 9) Sags: Lowest sag, day 01, channel A, 108 volts. A total of 1 sag, day 01.
- 10) Impulses: Largest impulse, day 01, channel A, 140 volts. A total of 5 impulses, day 01. Other 4 impulses  $\leq$  140 volts (and  $\geq$  threshold, of course).

NOTE: "HTS" means "HITS" or total disturbances.

Similar data presented for channels B and C. Note that summaries of sags, surges and impulses include the worst case disturbances, together with the total number of disturbances.

Following the summary report, the day counter is advanced and the accumulators are reset to 0.

## SHORT TERM ACCUMULATION

### Sample printout:

```

IMP 05000 0020 HTS
HI AVERAGE 1120
C 1120 AU 00:02:01
HI AVERAGE 1130
B 1120 AU 00:01:50
HI AVERAGE 1130
A 1130 AU 00:01:54
HI FREQ 060.0HZ
FREQ 060.0HZ
TEST DAY 00 ACCUM
    
```

```

IMP 03000 0007 HTS
C 1120 AU 00:01:35
B 1120 AU 00:01:33
A 1120 AU 00:01:30
FREQ 060.0HZ
SHORT TERM ACCUM
    
```

```

C 03240 IMPULSE
C 03800 IMPULSE
C 03640 IMPULSE
C 03680 IMPULSE
C 03560 IMPULSE
C 03640 IMPULSE
C 03520 IMPULSE
C 03680 IMPULSE
C 03560 IMPULSE
C 03520 IMPULSE
C 03520 IMPULSE
C 03440 IMPULSE
C 03320 IMPULSE
C 03240 IMPULSE
C 03160 IMPULSE
C 02880 IMPULSE
C 05000 IMPULSE
00 00 57
    
```

### EXPLANATION:

A. A total of 20 impulses occurred starting at 00:00:57.

B. 17 impulses were printed; then 606 went into short term accumulation printing overflow in "Short Term Accum."

C. In test message, all 20 impulses are shown. Note that "Short Term Accum" includes only the 3 impulses which occurred after the first 17 were printed.

### FIGURE 6

(Read Tape Bottom To Top)

TABLE 1 — OPERATING CONTROLS AND INDICATORS — FRONT PANEL

OPERATING CONTROLS AND INDICATORS — FRONT PANEL

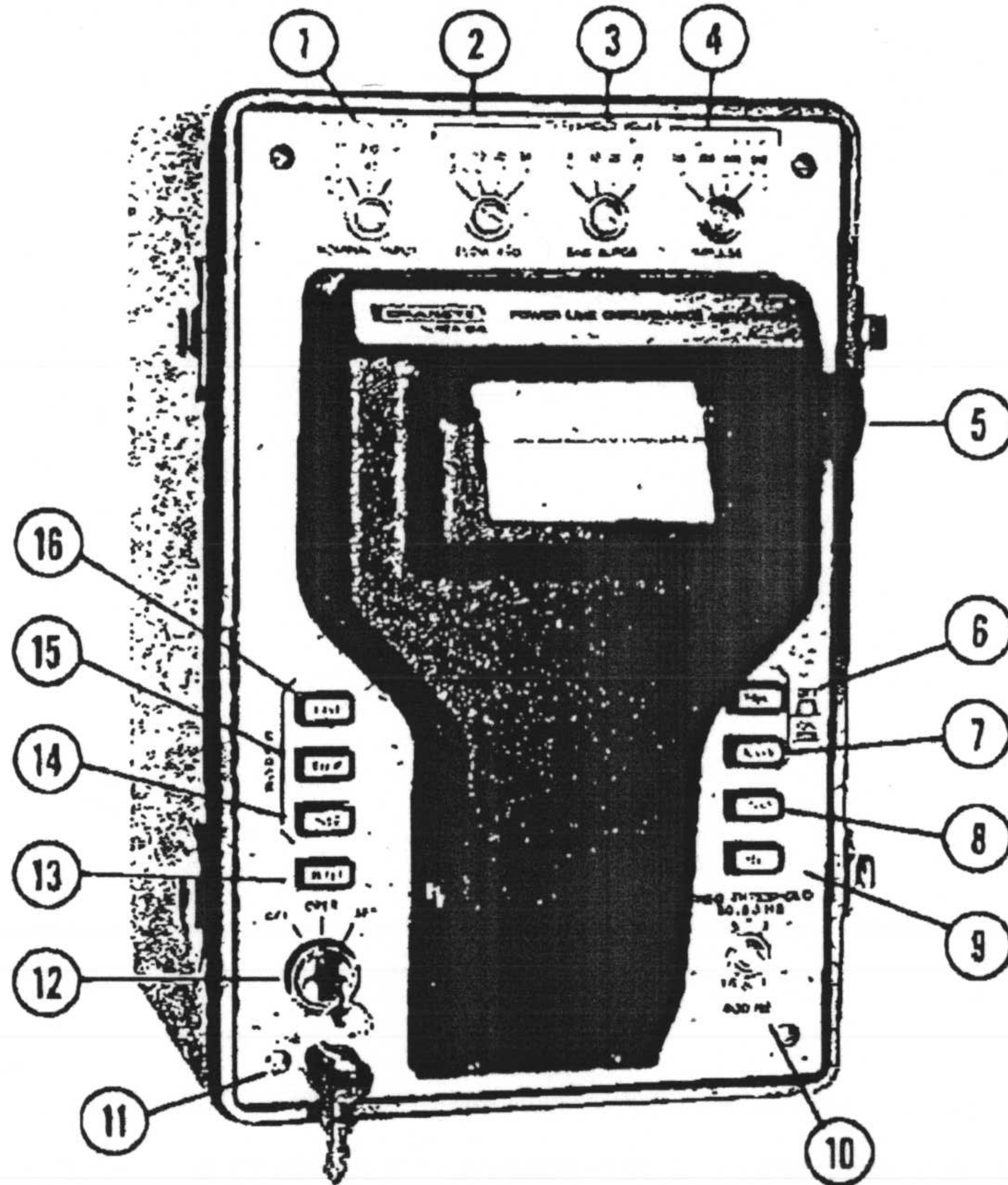

FIGURE 7

Index No.	Controls Or Indicators	Functions
1	NOMINAL INPUT switch (not on 616)	Sets nominal range of monitored voltage to 115 volts (X1), 230 volts (X2) or 460 volts (X4) RMS ( $\pm 50\%$ , 600 VAC max.)
2	THRESHOLD VOLTS - SLOW AVG switch	Selects one of four threshold voltage values for slow average disturbances. Range in effect corresponds to setting of NOMINAL INPUT switch (color coded with respect to nominal input settings.)
3	THRESHOLD VOLTS-SAG/SURGE switch	Selects one of four threshold voltage values for SAG/SURGE disturbance. (Range is color coded as for SLOW AVG switch.)

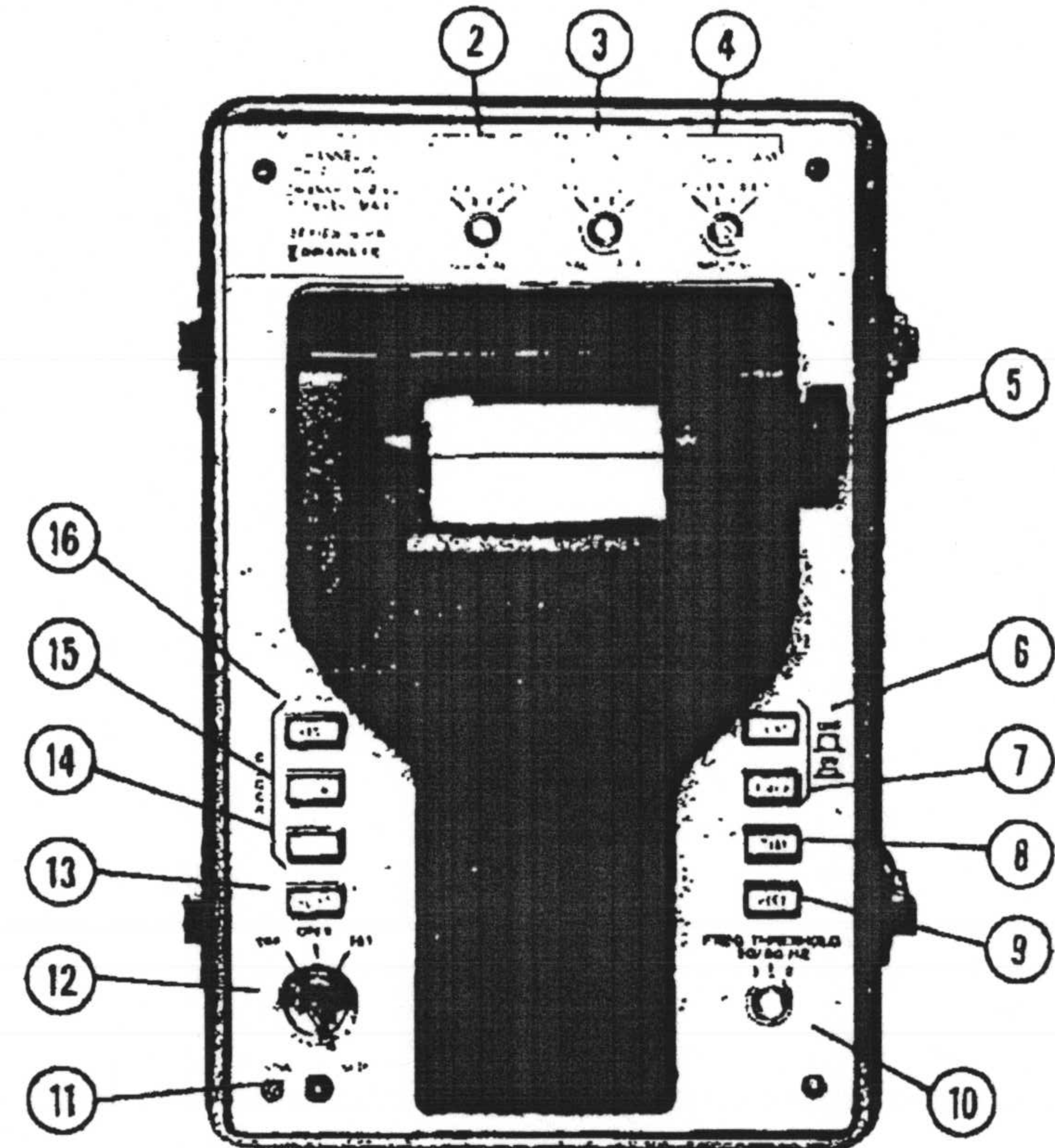

FIGURE 8

Index No.	Controls Or Indicators	Functions
4	THRESHOLD VOLTS— Impulse switch	Selects one of four threshold voltage values for IMPULSE disturbances. (Range is color coded as for SLOW AVG switch.)
5	Paper Advance Knob (not in models after 1978)	Provides manual means of advancing paper tape.
6	PRINT Pushbutton	When depressed to "in" position, normal printout of disturbance data is enabled. When in "out" position, the unit prints out PRINT OFF and time, and further printout is inhibited unless one of the following occurs: 1. TEST button is depressed. 2. Power is turned off or on. 3. End of day produces daily accumulated summary.

TABLE 1 — OPERATING CONTROLS AND INDICATORS (con't)

Index No.	Controls Or Indicators	Functions
6	(Continued)	4. When PRINT Pushbutton is again depressed to the "in" position, all data stored while the printer was off is printed in a "Short Term Accum" message.
7	ALARM pushbutton	When depressed to "in" position, the alarm circuit is enabled and audible alarm is sounded in accordance with each disturbance.
8	TEST pushbutton	When depressed, unit prints TEST, followed by daily accumulated summary.
9	FEED pushbutton	When depressed, paper tape advances out of printer.
10	FREQ. THRESHOLD switch (optional)	Option 101: (606-3 and 616 only): Selects one of three frequency threshold values (45-65 Hz operation). Option 103: (606-3 with Option 101 only): Selects one of three frequency threshold values (45-65 Hz or 380-450 Hz. Internal switch selects range.)
11	LINE-BATT dual LED indicator	Indicates instrument power source; green for line, red for internal battery (standby mode).
12	Key operated mode switch	OFF position: Instrument is off and key is locked. OPER position: Instrument is on, key may be removed, but CLOCK and RESET buttons are inoperative. SET position: Clock and reset circuits are enabled and key is locked.
13	RESET pushbutton	When depressed (mode switch in SET position), unit prints RESET, day count is reset to 00, accumulated summary is printed and all data is cleared from memory. Instrument clock is not affected.
14	CLOCK HOLD pushbutton	When depressed, freezes instrument time at its last value.
15	CLOCK SLOW pushbutton	When depressed, advances instrument time at slow rate (1 min/sec).
16	CLOCK FAST pushbutton	When depressed, advances instrument time at fast rate (1 hr/sec).

MISCELLANEOUS FUNCTIONS

1) OPTION 103 (Model 606-3 with Option 101 only)

This option allows monitoring of voltage and frequency on 380-450 Hz power lines. To use Option 103, first turn the power switch on the front panel off, and remove the power cord. Loosen the 2 captive screws in the upper rear cover (Figure 10) so that the cover swings free.

Now remove the blue case. Referring to Figure 10, remove the 4 case securing screws (with lock washer). Next remove the 2 screws on the right side of the case, near the front (same side as the S/N label). DO NOT remove any screws from the front panel. Gently slide the chassis out from the front of the case. Light pressure on the rear terminal strip may assist removal.

Carefully set the 606 chassis on its backside with the bottom toward you. The second PC card from the bottom is A2, and the Option 103 toggle switch is near the center. Note the label "up 400 Hz." Place the toggle in the desired position (never use the center position, if one is available). Re-install the 606 chassis in the case, remembering to secure with all 6 screws.

2) INSTALLATION OF PAPER TAPE (See Figure 9)

The analyzer is shipped with a roll of paper already installed. During operation, when the paper supply becomes low, the unit will automatically print PAPER LOW (and operation will be shifted to the "PRINT OFF" mode) indicating that the paper roll should be replaced. Replace paper roll while some paper is still left in the printer. If this is not done, refer to procedure in Operator's Manual. Before replacing the thermally sensitive paper, clean the printhead as described below. After cleaning the printhead, replace the paper roll as follows:

a. Depress upper edge of paper and printer cover and lower cover as shown in Figure 9.

b. Tear paper roll just above old roll. Do not remove remaining paper from printer.

c. Push two spring paper holders outward to release old paper roll and remove roll.

d. Remove holding tab from new paper roll to release end of roll. Use a scissors to cut the edge of the paper straight.

e. Holding the paper roll so that it unrolls as shown in Figure 9, expand the two spring paper holders, install the roll, then release the holders to lock the roll in place.

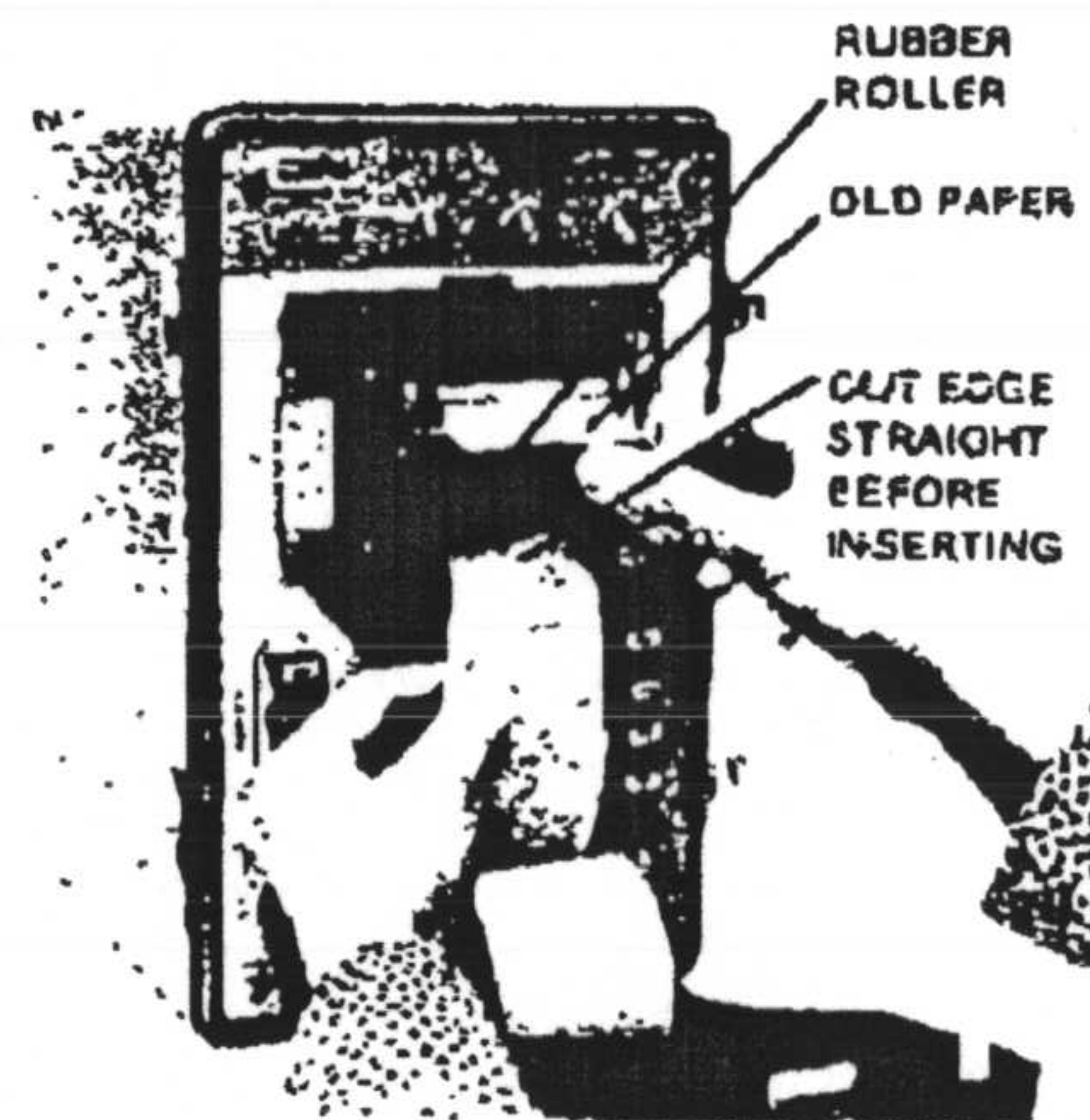

FIGURE 9

f. Ensuring that the new paper is aligned correctly to avoid jamming, insert the cut end between the rubber roller and the remaining old paper so that the old and new paper overlap.

g. Depress and hold FEED pushbutton until the new paper comes into view and the old paper is completely out of the printer.

h. Raise the cover and guide paper through opening as shown in Figure 7, then lock cover in place.

### 3) CLEANING PRINTHEAD

To clean the printhead in the simplest and preferred method, particles may be removed by inserting a length of bond paper (approximately 10 inches in length cut to width of 2.25 inches) into the printer, and operating the printer by pressing the TEST button until the length of paper passes through the printer. Insert this paper in the same manner as if replacing the paper roll.

TABLE 2 — REAR PANEL FUNCTIONS

Index No.	Controls Or Indicators	Functions
1	Upper Rear Cover	Use to cover input terminals
2	Alarm Contacts	Internal relay contact closure for 1 second each time a disturbance occurs
3	Signal inputs	Allow connection of up to 3 AC power signals (606) or 1 AC and 2 DC signals (616).
4	Option 102 switch (protective cover)	Allows selection of 120/240 VAC operation.
5	Option 105 and/or Option 106 connector	Allows connection of interface cable for use of 606-PA-600X series and/or RS-232C.
6	Power cord connector	For installation of removable power cord
7	Option 104 input (time mark)	Application of signal changing Low — High (0 - 5 VDC up to 0 - 12 VDC) causes printout of time. TAPE: 0009 CYCLES A 1540 SAG 16:02:19 #16:02 17 ← OPTION 104 ACTIVATED
8	Case Securing Screws (with lock washers)	

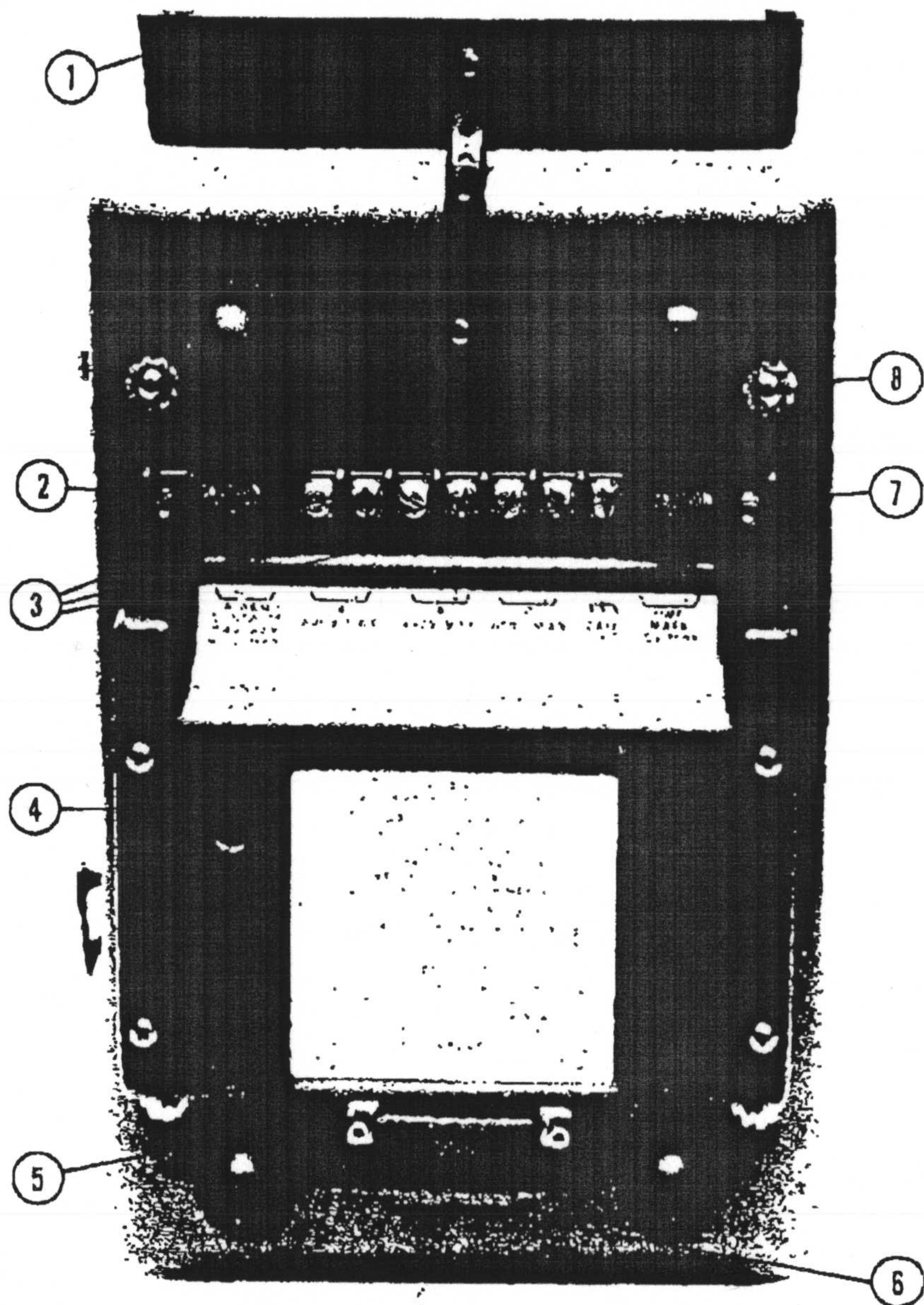

FIGURE 10

SEE PAGES (18-25) FOR CONNECTION INSTRUCTIONS

## DISTURBANCE MEASUREMENTS

### Frequency Variations

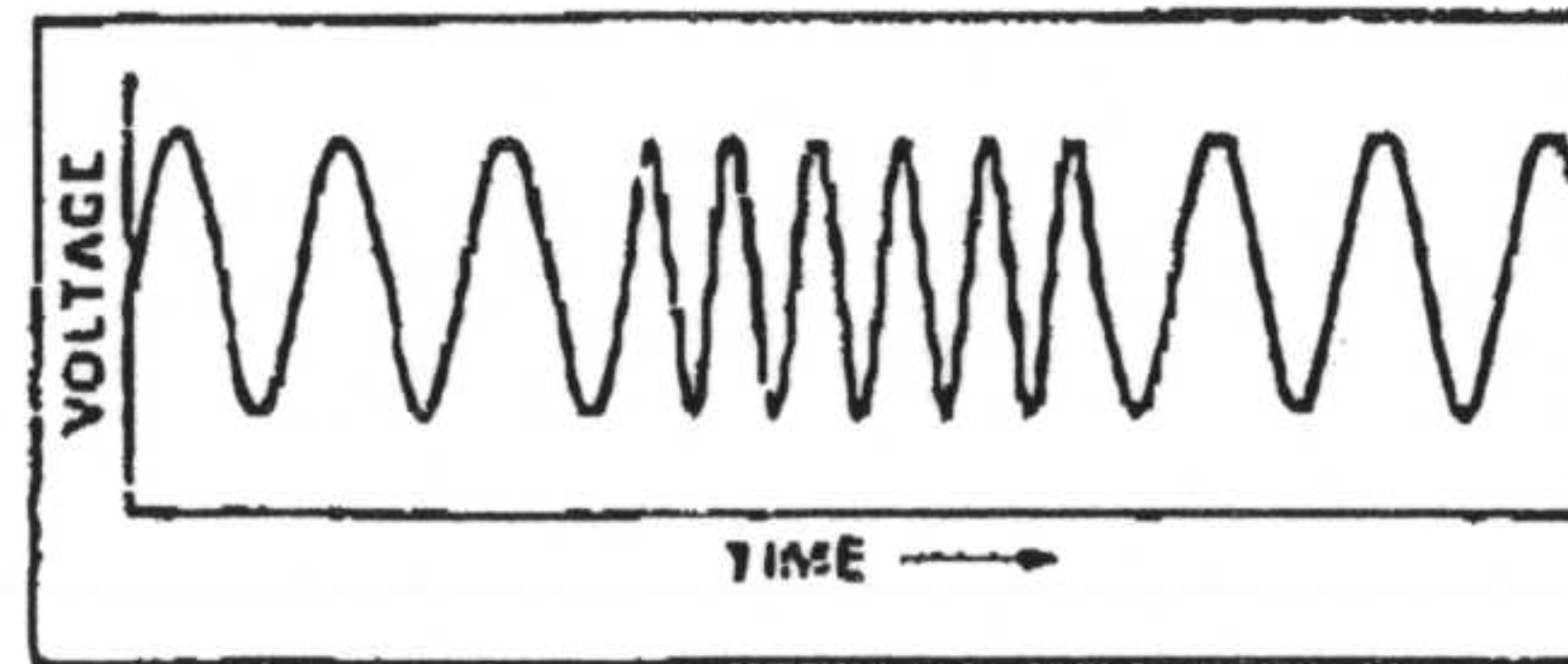

Figure 11. Frequency Disturbance

Since Channel A is the only phase from which the frequency printout is derived, when frequency of that voltage deviates by more than the selected threshold value, a printout is produced as follows:

FREQ 060.5 Hz +  
04:09:48

This printout indicates that at 04:09:48 the FREQUENCY increased (+) to 60.5 Hz. Since the frequency measurement is based upon counting cycles over a one second interval, a voltage interruption could cause a frequency disturbance to be printed. Therefore, in the case of an interruption, the recorded frequency could fall as low as 42.7 Hz. 42.7 Hz corresponds to the free running frequency of the Phaselock Oscillator.

### Slow Average Variations

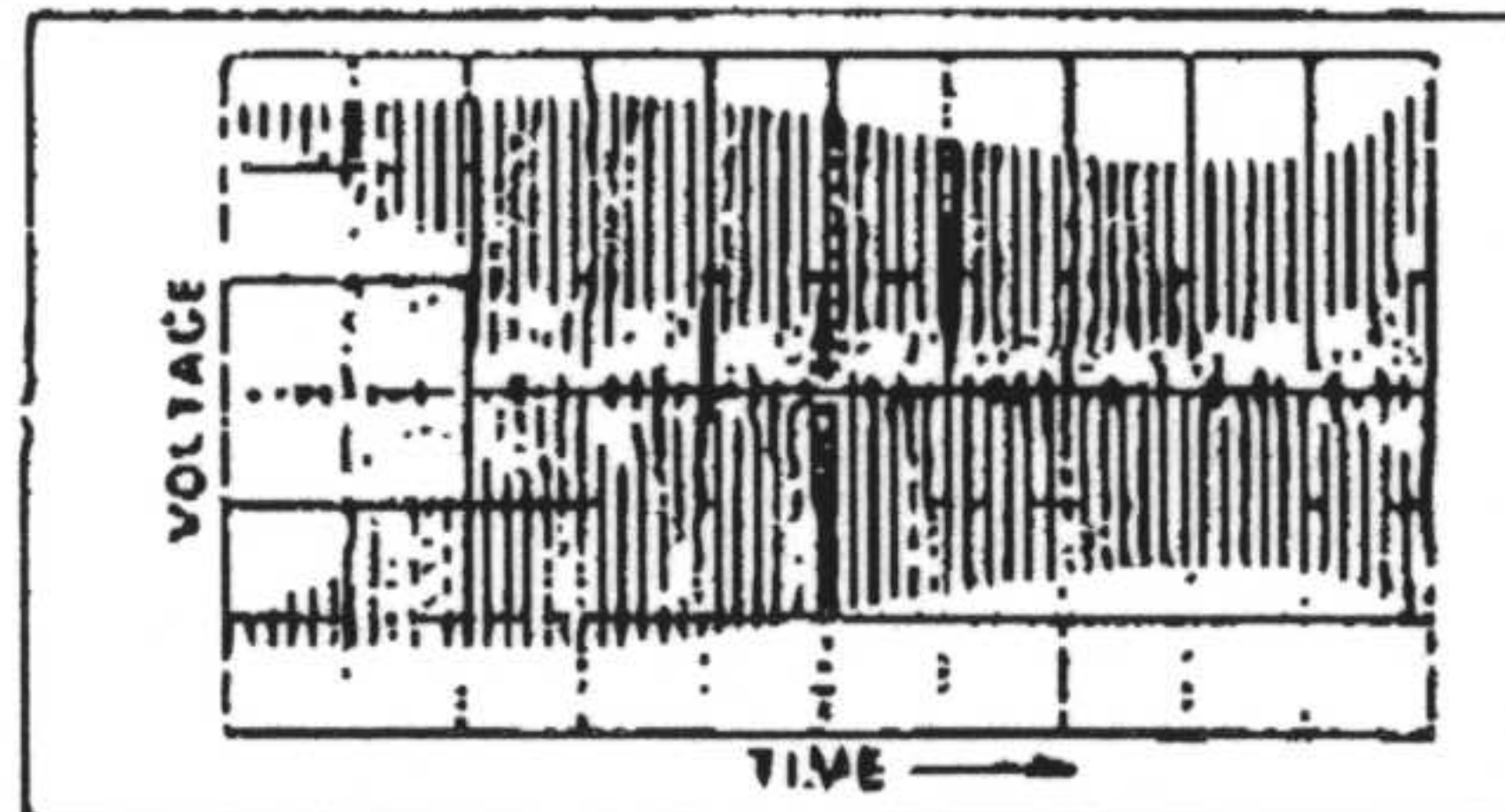

Figure 12. Slow Average Disturbance

The slow average measurement represents a steady state RMS level based on a 10-second moving average of the monitored voltage. As an example, the printout:

A 130V AVG+  
16:29:03

indicate that the channel A slow average voltage (AVG) increased (+) to 130 volts RMS at 16:29:03. This disturbance data is not printed until the slow average voltage moves by more than the threshold setting from the previously printed AVG+ or AVG-.

## SAG/SURGE TRANSIENTS

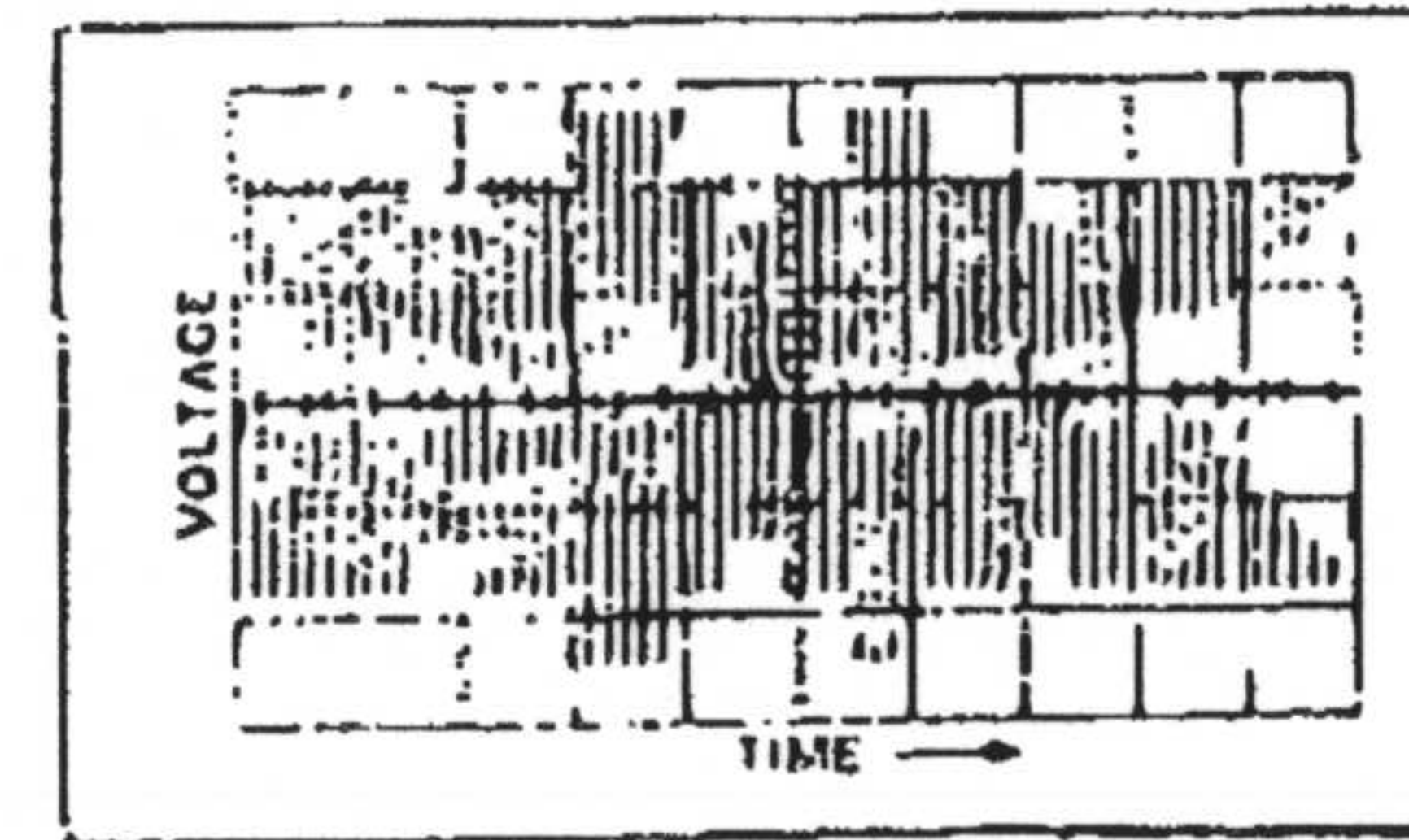

Figure 13. Sag and Surge Disturbances

The model 606-3 measures the RMS value of each AC cycle and compares it with the present slow averaged steady state RMS level. If the single cycle measurement is lower, the 606-3 recognizes a SAG; if higher, it recognizes a SURGE. If the RMS change exceeds the SAG/SURGE threshold setting, a printout similar to the following occurs:

0013 CYCLES  
B 124V SURGE  
13:28:21

At 13:28:21 the voltage on channel B increased (SURGE) to 124 volts RMS and remained more than the threshold setting above the slow average level for 13 cycles. (1 cycle = 16.6 milliseconds at 60 Hz and 20 milliseconds at 50 Hz.)

### IMPULSE TRANSIENTS

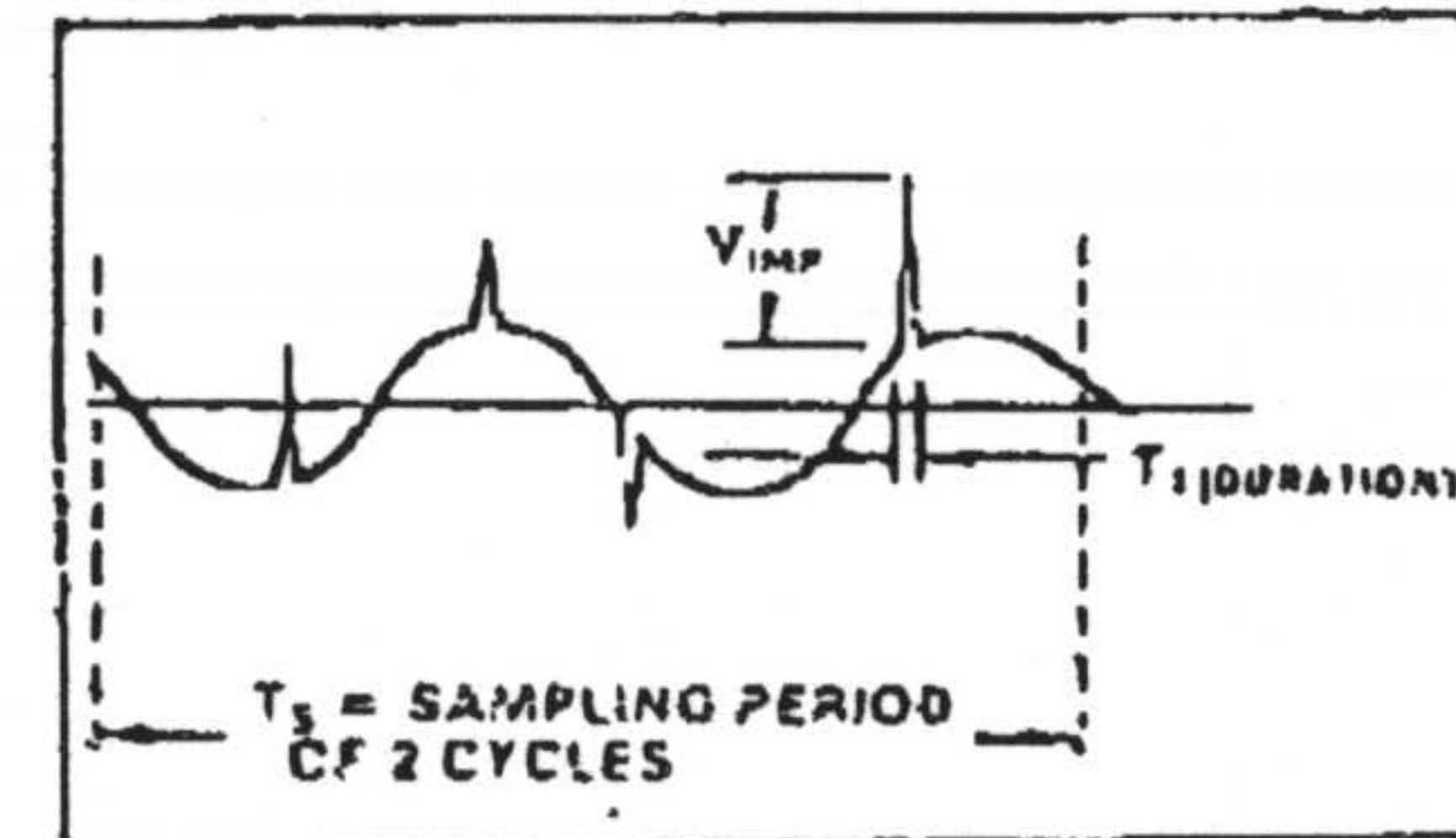

Figure 14. Impulse Disturbances

Impulses (spikes and notches) with a duration between 0.5 and 800 microseconds are continuously monitored by the 606-3. The instrument samples each channel in 2 cycle periods, holding the highest peak value (excluding the normal AC waveform). If the largest impulse measured in any 2 cycle interval exceeds the IMPULSE threshold setting, a printout similar to the following occurs:

C 0144V IMPULSE  
B 0195V IMPULSE  
17:59:01

At 17:59:01, two IMPULSES, differing from the normal AC waveform by 144 volts peak and 195 volts peak, were detected on channels C and B respectively.

## CONNECTION INSTRUCTIONS — SERIES 606

The Series 606/616 are extremely versatile instruments which are designed to provide important data on a wide variety of power line disturbances. The three independent, isolated channels enable the 606/616 to monitor virtually any power system in several ways, depending upon the user's particular application requirements. The following power systems and monitoring arrangements are suggested as typical applications.

### OPERATING POWER — NOTE

Option 102 provides the capability of operating from a single phase 180-280 volt, 45-65 Hz power line as well as from the standard single-phase 90-140 volt, 45-450 Hz power line. The line voltage selector switch (visible through a window in the rear plastic cover) determines which nominal voltage value (115 or 230) is required. The operating power has no relation to the power which is being monitored by the 606/616. Refer to the detailed procedure in the Operator's Manual before applying power to the Model 606-3. Note that 606-PA-6002 and 606-PA-6004 Impulse Analysis Adapters have their own power supplies, and must be provided with option 102 when option 102 is required by 606.

### WARNING

Connection should only be performed by qualified personnel. Conductors connecting to measurement points should be approved for the specific use. When connected to branch circuits of 20 amperes or less, minimum flexible cord size is No. 12. For branch circuits with higher ampacity, refer to National Electric Code (ANSI C1-1975 Para. 240-4 and Para. 250-95). Special consideration of ground may be required. Refer to Article 250 of above reference if in doubt.

### Model 606-1 (Single Channel)

#### 3-Wire Wall Receptacle

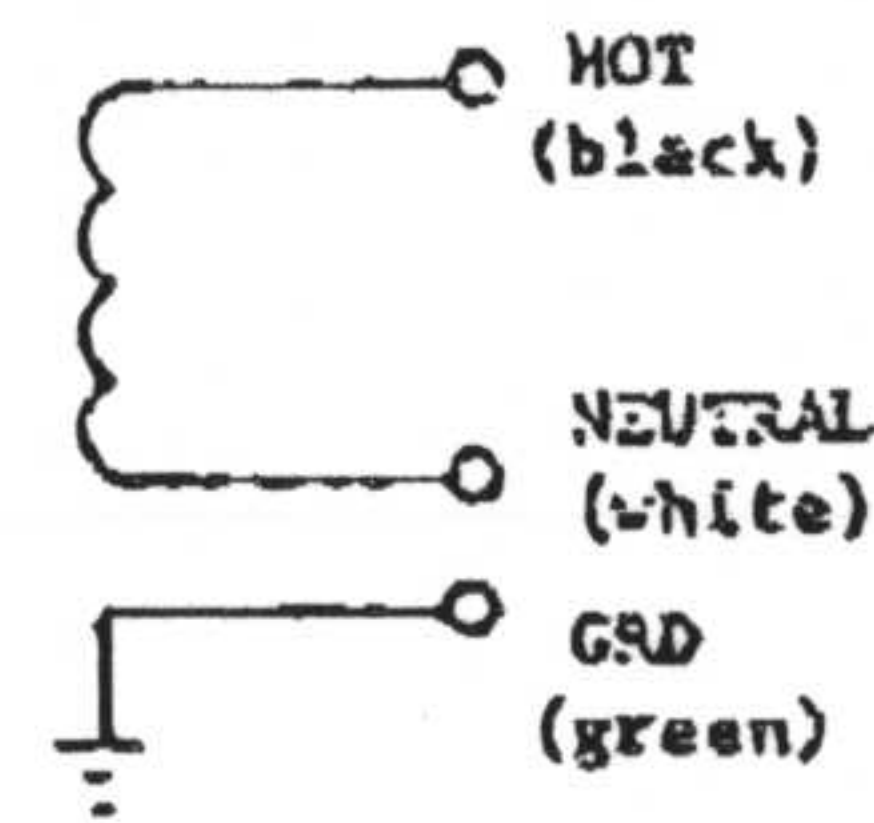

#### Nominal Input Switch = 115V

Channel	Mode	Terminal	Wire
A	Normal	A1	Black
		A2	White

Green wire to Frame Ground Terminal

### Model 606-3 (Three Channel)

#### NOTE

When monitoring fewer than 3 phases, Channel A must be connected to the AC power. This input controls timing and must be provided with the following minimum voltages for proper operation:

for Range = X1,      A input = 32 volts min. (also for 616-A)  
 for Range = X2,      A input = 64 volts min. (Also for 616-B and 616-C)  
 for Range = X4,      A input = 128 volts min.

In all cases, the green wire should be connected to the frame ground terminal.

#### 3-Wire Wall Receptacle

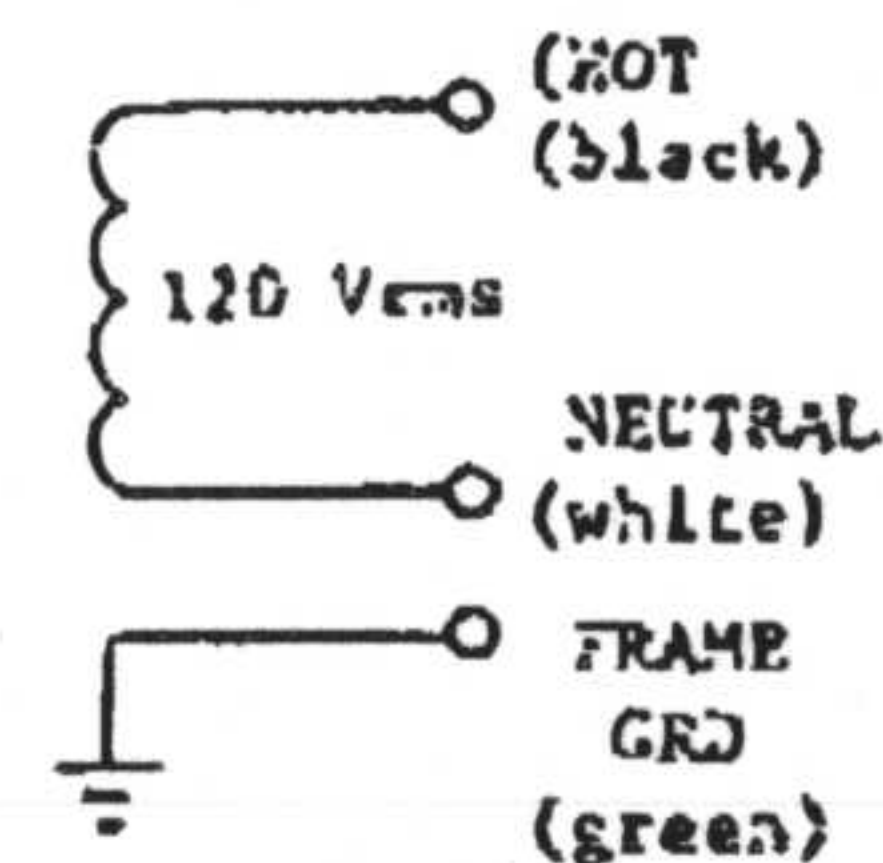

#### Nominal Input Switch = 115V

Channel	Mode	Terminal	Wire
A	Normal	A1	Black
		A2	White
B	Common	B1	Black
		B2	Green
C	Common	C1	White
		C2	Green

**CAUTION: ALWAYS VERIFY PROPER VOLTAGES WITH A VOLTMETER BEFORE APPLYING POWER TO ANY PART OF THE MODEL 606 OR 616.**

**Three-Phase  
120/208V WYE  
with Grounded  
Neutral**

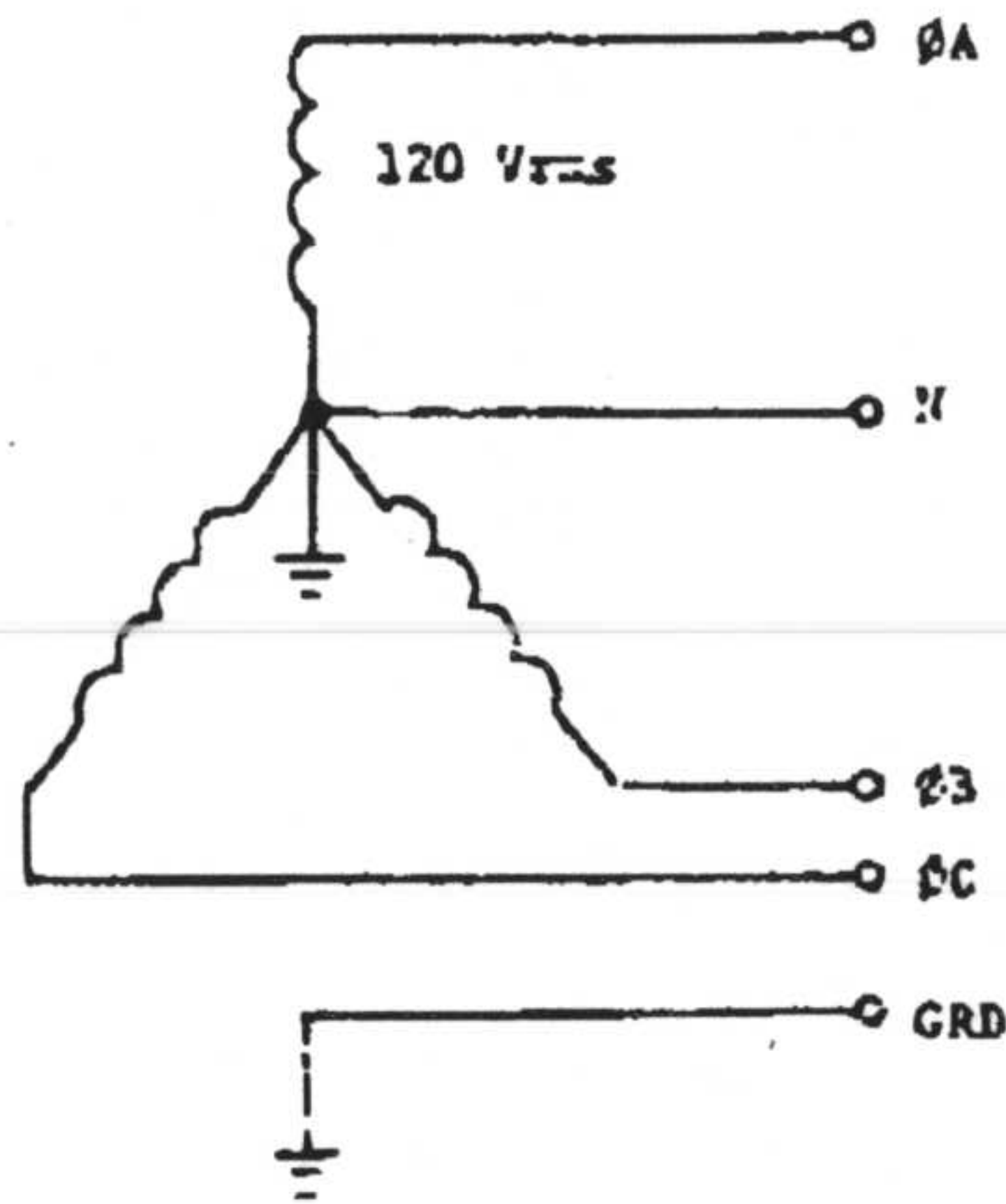

**Arrangement I: Nominal Input  
Switch = 115**

Channel	Mode	Terminal	Wire
A	Normal	A1	ØA
		A2	N
B	Normal	B1	ØB
		B2	N
C	Normal	C1	ØC
		C2	N

**Arrangement II: Nominal Input  
Switch = 230**

Channel	Mode	Terminal	Wire
A	Normal	A1	ØA
		A2	ØB
B	Normal	B1	ØB
		B2	ØC
C	Normal	C1	ØC
		C2	ØA

**Three-Phase  
120/208V WYE With  
Ungrounded Neutral**

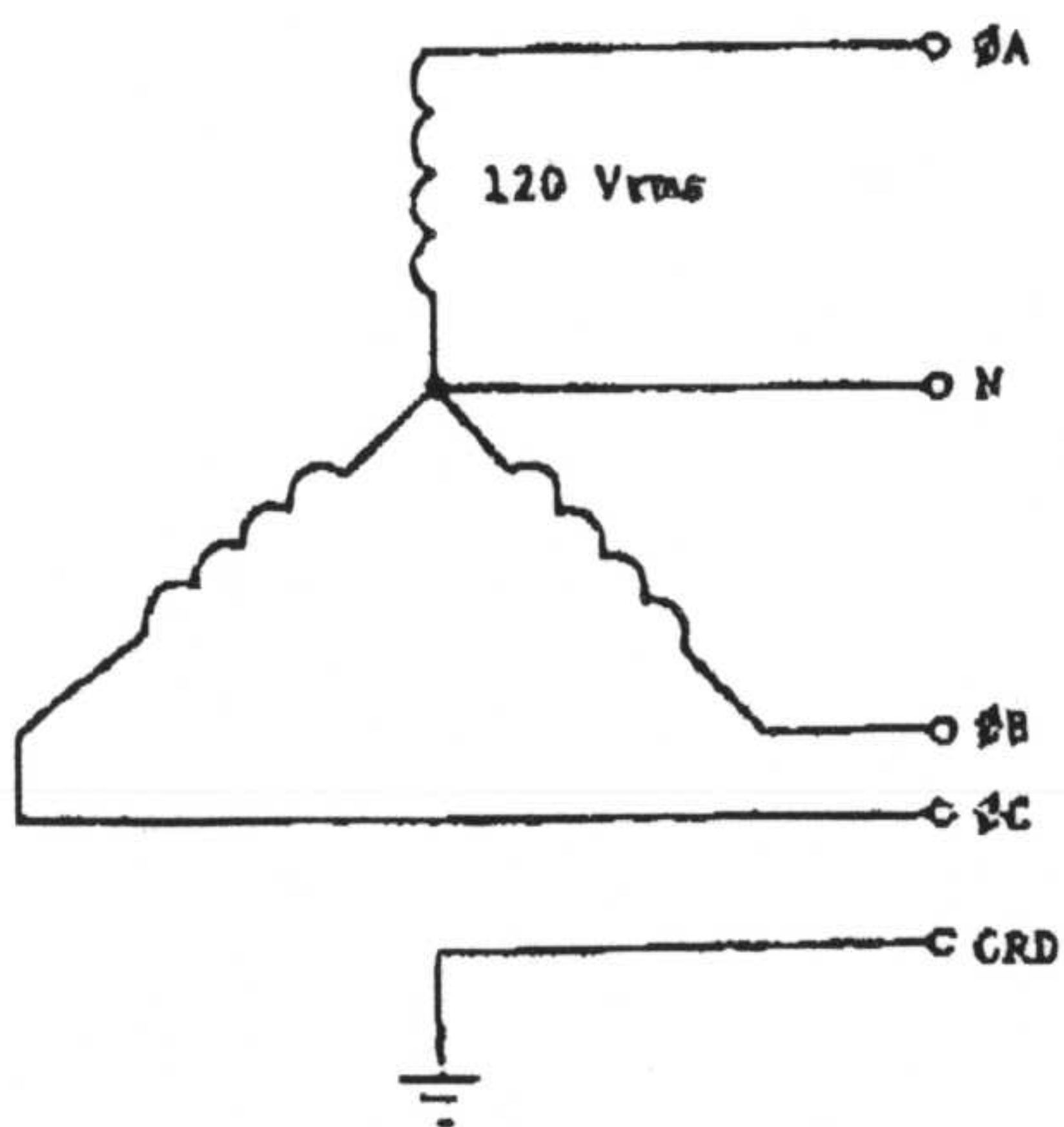

**Arrangement I: Nominal Input  
Switch = 115**

Channel	Mode	Terminal	Wire
A	Normal	A1	ØA
		A2	N
B	Normal	B1	ØB
		B2	N
C	Normal	C1	ØC
		C2	N

**Arrangement II: Nominal Input  
Switch = 230**

Channel	Mode	Terminal	Wire
A	Normal	A1	ØA
		A2	ØB
B	Normal	B1	ØB
		B2	ØC
C	Normal	C1	ØC
		C2	ØA

**Arrangement III: Nominal Input  
Switch = 115**

Channel	Mode	Terminal	Wire
A	Normal	A1	ØA
		A2	N
B	Normal	B1	ØB
		B2	N
C	Common	C1	N
		C2	Grd

**Arrangement I: Nominal Input  
Switch = 230**

Channel	Mode	Terminal	Wire
A	Normal	A1	ØA
		A2	ØB
B	Normal	B1	ØA
		B2	N
C	Normal	C1	ØB
		C2	N

**120/240V Single Phase**

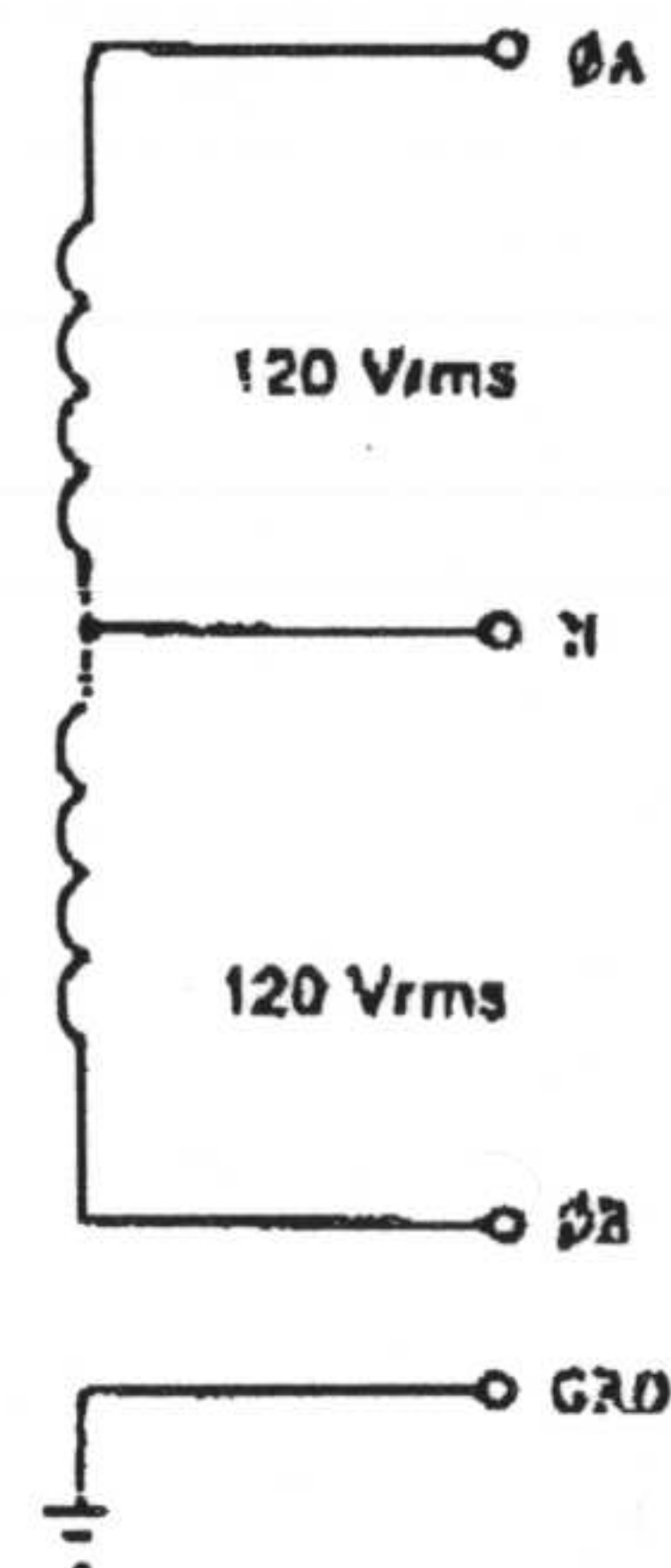

**Arrangement II: Nominal Input  
Switch = 115**

Channel	Mode	Terminal	Wire
A	Normal	A1	ØA
		A2	N
B	Normal	B1	ØB
		B2	N
C	Common	C1	N
		C2	Grd

Three Phase  
240V Ungrounded DELTA

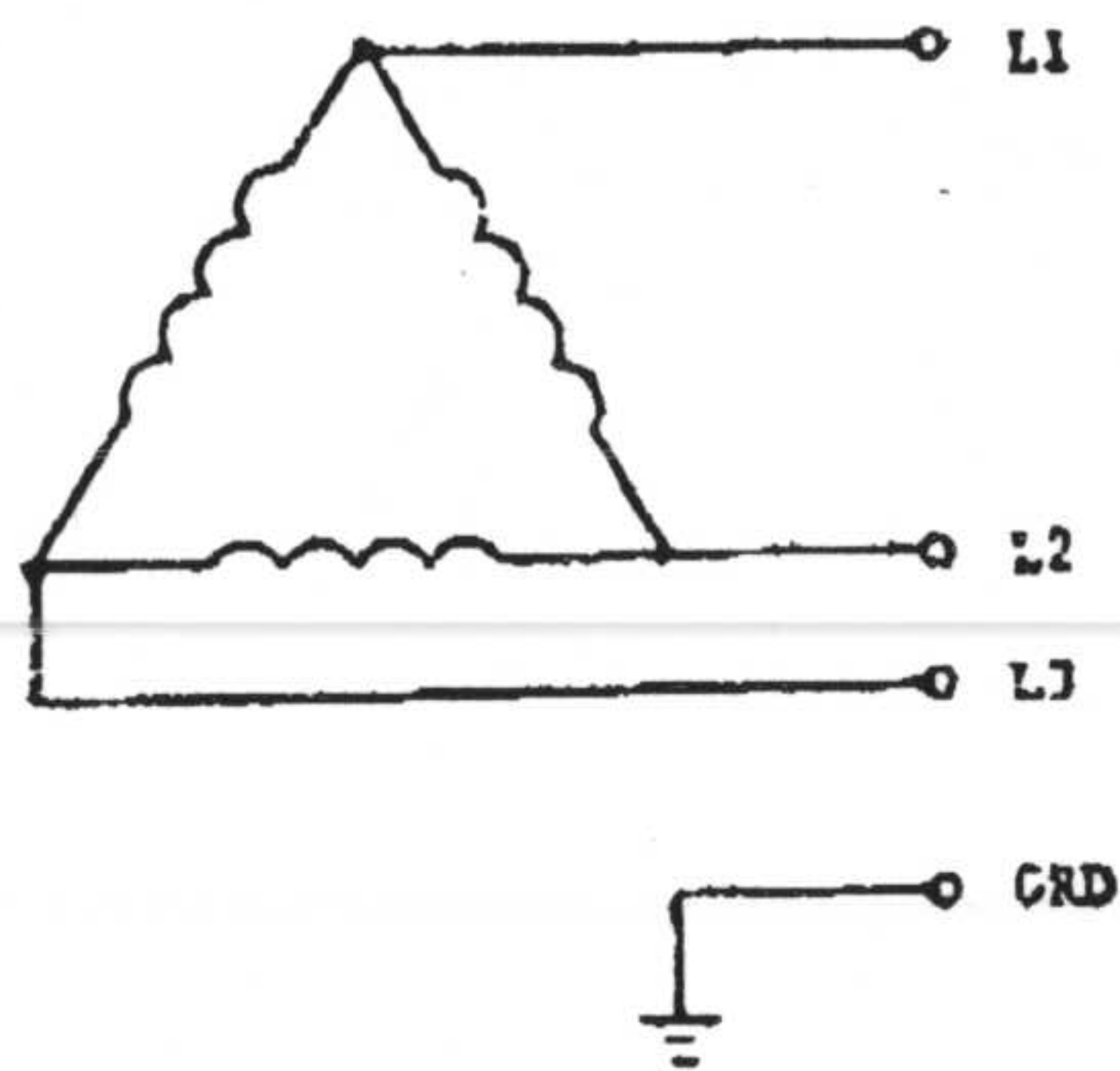

Arrangement I: Nominal Input  
Switch = 230

Channel	Mode	Terminal	Wire
A	Normal	A1	L1
		A2	L2
B	Normal	B1	L2
		B2	L3
C	Normal	C1	L3
		C2	L1

Arrangement II: Nominal Input  
Switch = 230

Channel	Mode	Terminal	Wire
A	Common	A1	L1
		A2	Grd
B	Common	B1	L2
		B2	Grd
C	Common	C1	L3
		C2	Grd

**CAUTION**

ALWAYS VERIFY PROPER VOLTAGES WITH A VOLTMETER BEFORE APPLYING POWER TO ANY PART OF THE MODEL 606 OR 616.

CONNECTION INSTRUCTIONS — SERIES 616

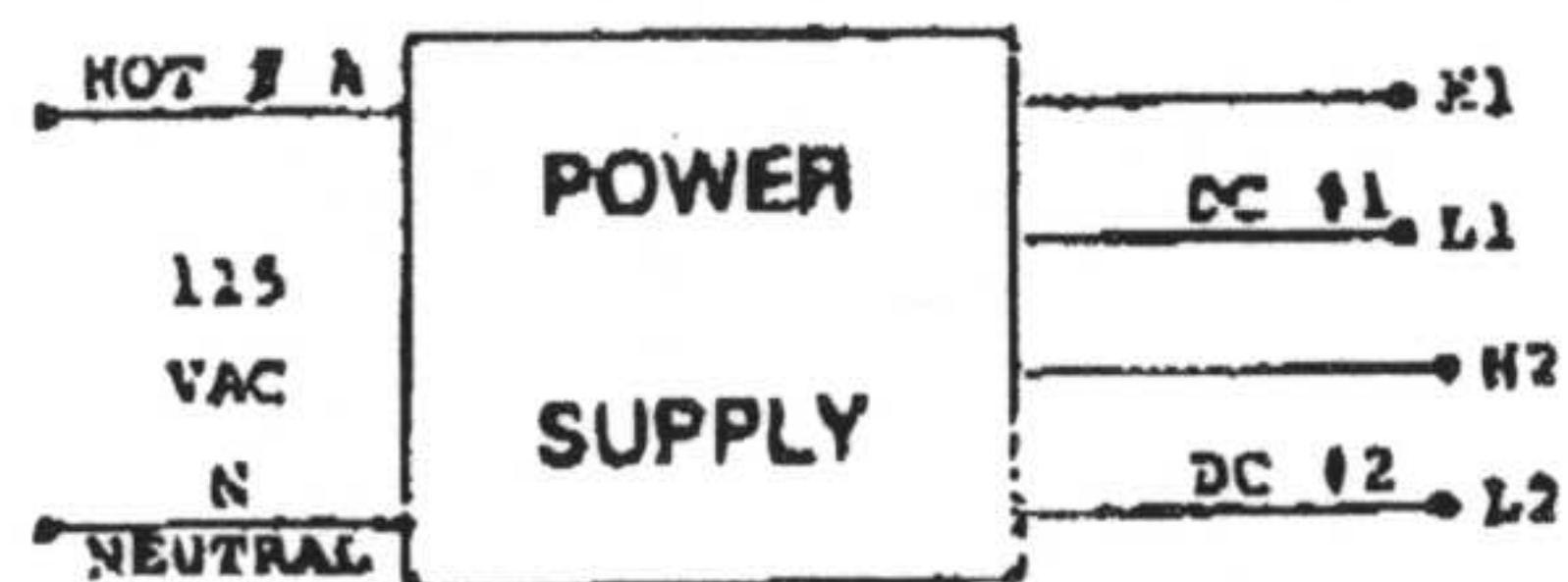

CHANNEL	TERMINAL	WIRE
A	A1	β A
	A2	N
B	B1	X1
	B2	L1
C	C1	X2
	C2	L2

616A: Channel A — 40 - 250 VAC  
Channels B & C — 4 - 25 VDC

616B: Channel A — 80 - 500 VAC  
Channel B & C — 8 - 50 VDC

616C: Channel A — 80 - 500 VAC  
Channels B & C — 12 - 75 VDC

CONNECTION DIAGRAMS — SERIES 606-PA-600X

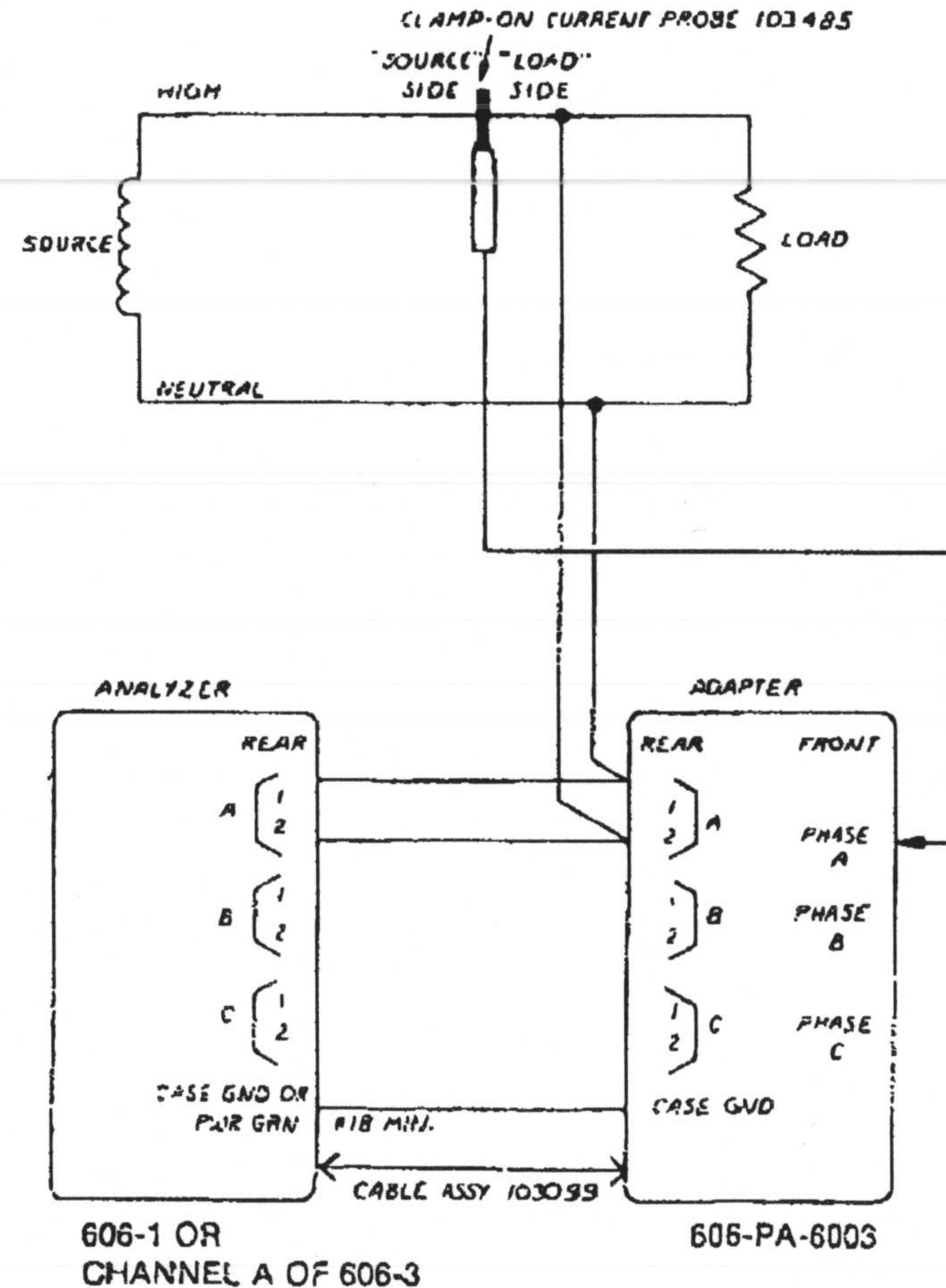

606-1 OR  
CHANNEL A OF 606-3

606-PA-6003

Connection of 606-PA-6003 to Single Phase Power Line

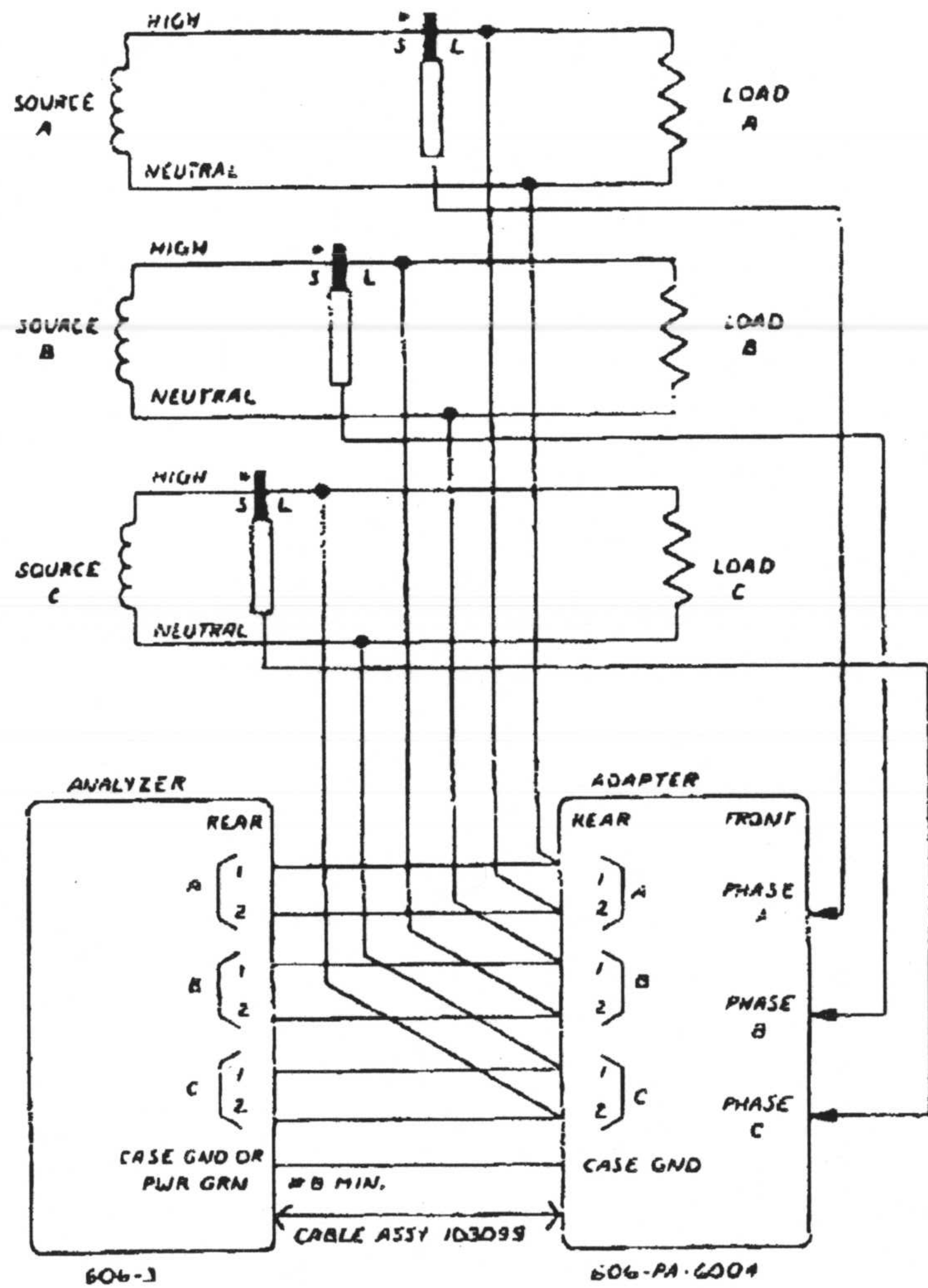

\* CLAMP-ON CURRENT PROBE 103485

Connection of 606-PA-6004 to Three Independent Power Lines

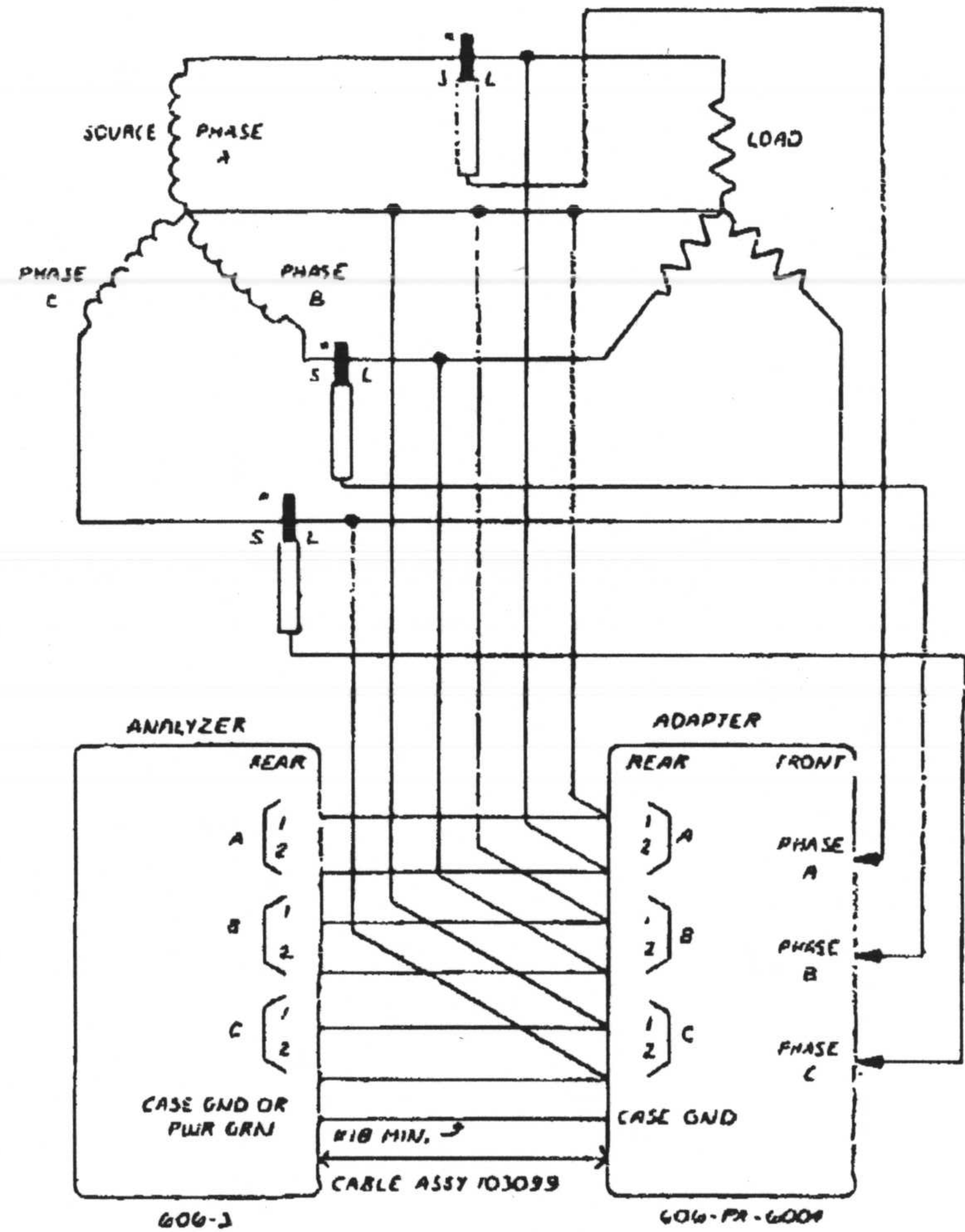

\* CLAMP-ON CURRENT PROBE 103485

Connection of 606-PA-6004 to 3-Phase 4-Wire Wye Line

**OPTION 106**  
**RS-232C INTERFACE ADAPTER**

**MODES OF OPERATION**

**Local Printer On, Remote Printer On**

The printer will echo whatever is printed on the 606/616.

**Local Printer Off, Remote Printer On**

In this mode of operation, the 606/616 printer is turned off in the normal fashion. Data is transmitted to the remote if it is operational; if not, the 606/616 will store the data in a summarized form. Should the remote become disabled, the 606/616 printer will automatically be activated.

**Remote Only Operation**

In this mode, the 606/616 printer is turned off at the front panel and prevented from being reactivated by means of an internal jumper. Now data will be transmitted to remote as long as it is operational. Should the remote become disabled, the data will be stored in summary form.

**FEATURES**

**Remote Test**

A TEST message may be generated from the remote location by typing "Control T".

**Choice of Baud Rates**

All standard baud rates are available, from 110 to 9600 baud. Selection is made with a switch installed on the interface cable supplied with Option 106.

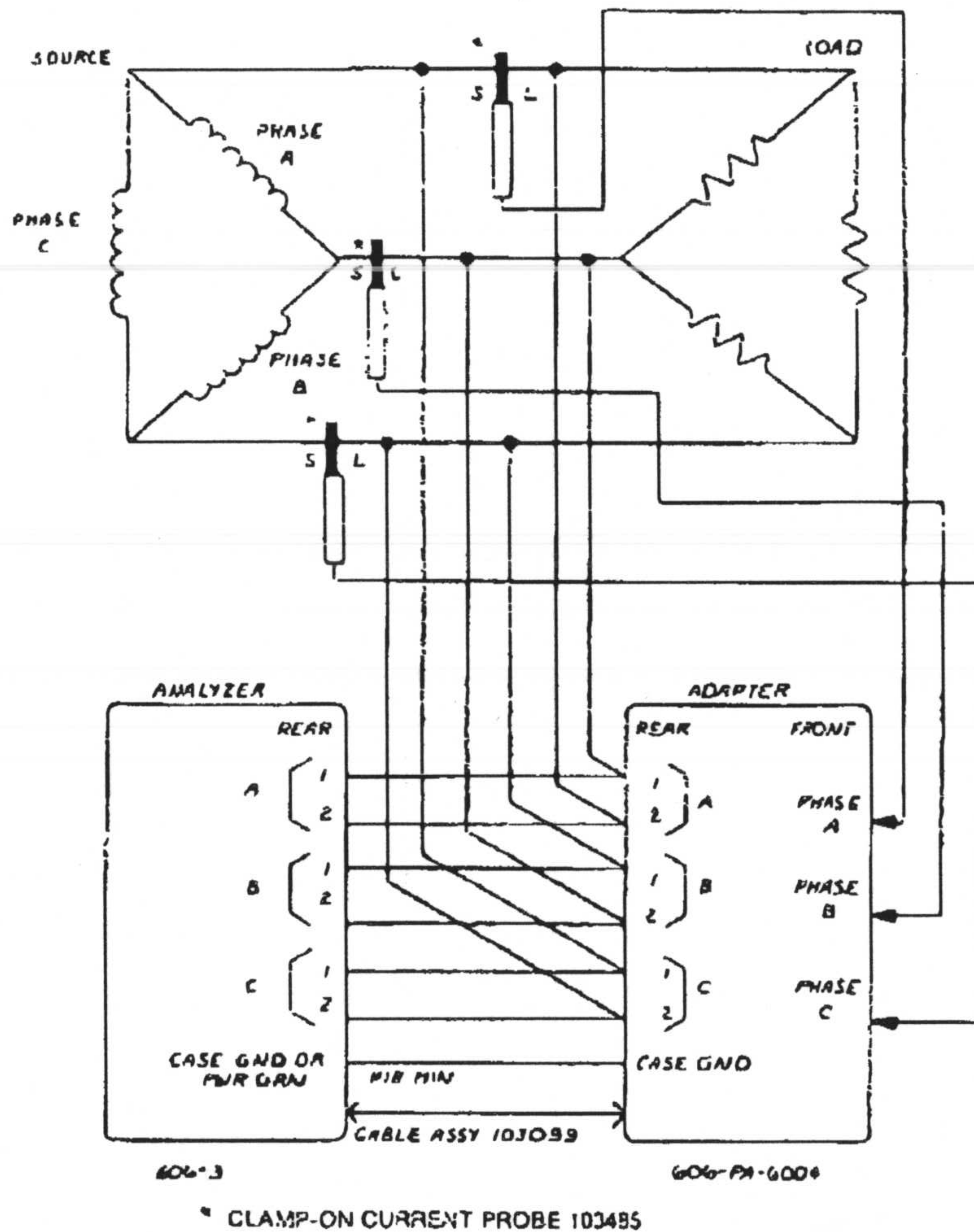

**Connection of 606-PA-6004 to 3-Phase Delta Line**