

# HP 85620A Mass Memory Module

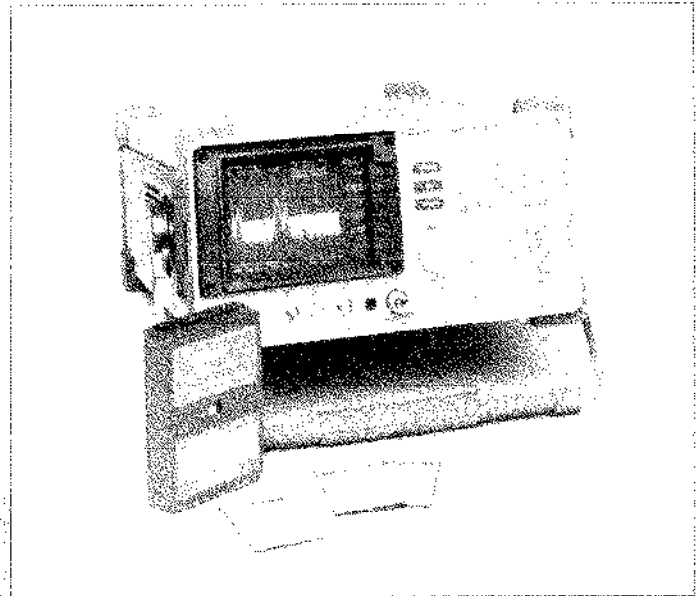

Add a MIL-rugged built-in computer to enhance your HP 8562A/B or 8561A portable spectrum analyzer.

Technical Data



**128K-bytes user memory + "credit card" memory**  
**Automatic trace storage**  
**Limit lines**  
**Downloadable programs**  
**Built-in clock/calendar**

When you connect the HP 85620A mass memory module to your HP 8562A/B or 8561A spectrum analyzer, it's like adding a built-in computer to your instrument. The module provides 128K-bytes of battery-backed, internal memory, all of which is available to the user. Need more than 128K? The module has the capability to expand its memory with the addition of credit-card-size, plug-in memory cards. The module also allows you to store and execute downloadable programs (DLPs), either of your own design or from Hewlett-Packard.

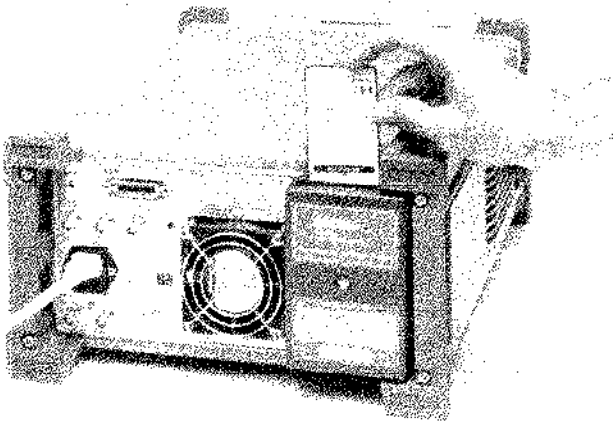

The mass memory module adds many other features and capabilities to your portable spectrum analyzer that save time and make your measurement tasks easier. The built-in clock/calendar automatically time and date stamps every trace that you save. With 128K-bytes of memory you can store approximately 100 traces and associated states. That's a ten-fold improvement in the trace storage capability of the standard HP 8562A/B or 8561A! Auto-execute, auto-save, and limit line functions help you simplify and automate time consuming procedures.

Add all these features and capabilities without sacrificing the ruggedness, portability, or EMC integrity of your analyzer and without increasing its size. Unlike many instrument upgrades, there are no expensive and time consuming hardware changes. The mass memory module, like the HP 85629A test and adjustment module, works with any HP 8562A/B or 8561A, and is easy to install. Just plug the module into the option module connector on the back of the analyzer, turn the locking screw, and the new features are installed and ready to use.

## **DOWNLOADABLE PROGRAMS (DLPs)**

### **Increase throughput and reduce operator training time**

DLPs are measurement routines that you create on an external controller and then download into the spectrum analyzer's memory. These routines can be simple measurement programs involving only a few commands, or they can be sophisticated programs that mathematically manipulate data and present results in a usable format. In addition to controlling the operation of the spectrum analyzer, DLP's can control other instruments over the HP-IB. You can tailor DLPs to meet your exact measurement needs. Hewlett-Packard is also developing DLP products that give your instrument a "personality." The HP 85710A digital radio personality, for example, simplifies many of the common measurements made on Digital Radio systems.

The mass memory module gives the HP 8562A/B and 8561A portable spectrum analyzers DLP capability similar to that of many other Hewlett-Packard analyzers. However, the mass memory module adds even more power with its large memory and built-in auto-execute function. The 128K of internal user RAM allows you to store many DLPs. Place up to ten of them on dedicated softkeys for easy identification and execution. You can also store DLPs on memory cards so that they can be loaded into the analyzer directly whenever they are needed.

Combine your DLPs with the module's auto-execute capability to automatically startup programs at pre-defined times and dates. In addition you can program the instrument to execute a DLP at specific time intervals, such as every hour or even every minute.

## LIMIT LINES

### Easy to use both manually and automatically

Limit lines are the perfect solution for pass/fail testing in a production or field maintenance environment. The mass memory module lets you create limit lines using just the front panel softkeys of the analyzer; an external controller is not required. Define limit lines to precisely match your measurement specifications by entering as many as twenty frequency and amplitude break points. With flexible on-screen menus, you can create dual limit lines to define a window with maximum and minimum values. You can also have your limit lines defined in terms of absolute or relative frequency and amplitude values. The mass memory module even has the capability to track the spectrum analyzer's settings and to adjust the limit line on the CRT accordingly. Use limit lines for manual testing or use the auto-save feature to save traces automatically when the limit line is exceeded. Title and save your limit lines in internal or "credit card" memory.

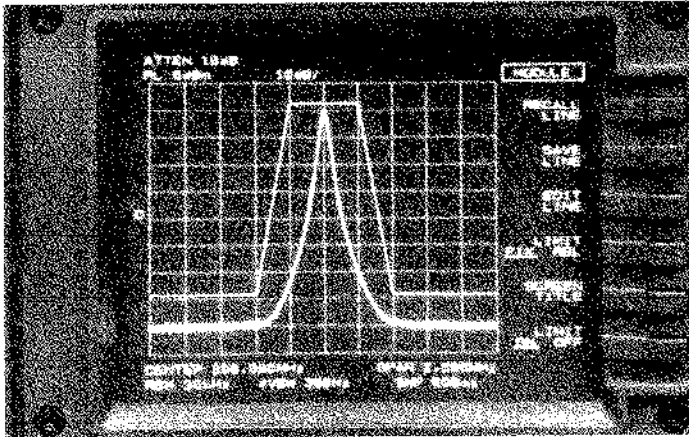

## AUTOMATIC TRACE STORAGE

### Unattended operation

With the mass memory module you can store traces automatically as well as manually. Using the auto-save menu you can define the criteria that will initiate a trace save routine. For example, begin by defining the time and date at which to start and stop saving traces. You can further define a trace to be saved at specific intervals; for example every five minutes. Or using the limit line capability, you can program for traces to be stored automatically when the limits are exceeded. In both cases you have the option of storing the traces in internal or "credit card" memory. With 128K-bytes of internal memory you can save approximately 100 traces and associated states. The 32K-byte RAM memory cards can store approximately 25 traces and states. Later recall these saved traces to the analyzer's CRT for comparison or analysis or to make hardcopies on a printer or plotter. All saved traces are time and date stamped for accurate and complete documentation. You can also add a trace title to simplify trace recall or to further clarify your documentation.

## MEMORY CARDS

### No need for a controller

The mass memory module gives the portable spectrum analyzers the capability to use a new development in memory technology: the "credit card" memory. One blank HP 85700A 32K-byte, battery-backed RAM card is included with each mass memory module, and you can order additional 32K-byte cards direct from Hewlett-Packard. With credit card memories the mass memory module has an expandable memory with virtually no size limit. When you need more memory, just plug in another memory card. With a typical battery life of five years, these cards are an excellent storage medium for a wide variety of information. Use the cards as a way of transferring data from analyzer to analyzer, facility to facility, or even country to country. Using the memory card to transfer data, you don't need a controller to download the information to the spectrum analyzer. Just plug the card into the mass memory module and use the information immediately.

Use the RAM memory cards to store your own custom DLPs, limit lines, or traces for comparison, analysis, or print-out. Personalities such as the HP 85710A digital radio personality will be on One Time Programmable (OTP) ROM cards. No matter what type of data you have on the card, it can be quickly and easily transferred to any portable spectrum analyzer with a mass memory module.

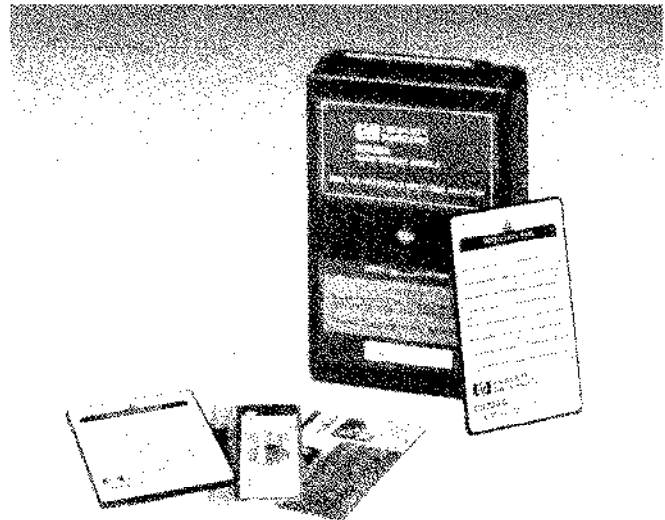

## SPECIFICATIONS

Specifications describe the instrument's warranted performance. Typical or nominal performance parameters are not warranted, but are included to provide information useful in the application of the product.

### HP 85620A Mass Memory Module

Compatibility: Works with any HP 8562A/B or 8561A

User Memory: 128K-byte battery-backed RAM

Clock Accuracy: +50, -120 ppm

Power Requirements: All power supplied by the analyzer

Battery: Lithium Iodine, 2.8V nominal, 1 amp-hour capacity

Battery Life: 1 year; typically 6.5 years

Environmental: MIL-T-28800C, Type III, Class 3 (same as HP 8562A/B)

Operating Temperature: -10° to +55° C (same as HP 8562A/B)

Storage Temperature: -62° to +85° C (same as HP 8562A/B)

Humidity: 95% @ 40° C for 5 days (same as HP 8562A/B)

EMC: Same as HP 8562A/B

Calibration Cycle: None required

Weight: 1.0 lb, 453 g nominal

Dimensions:

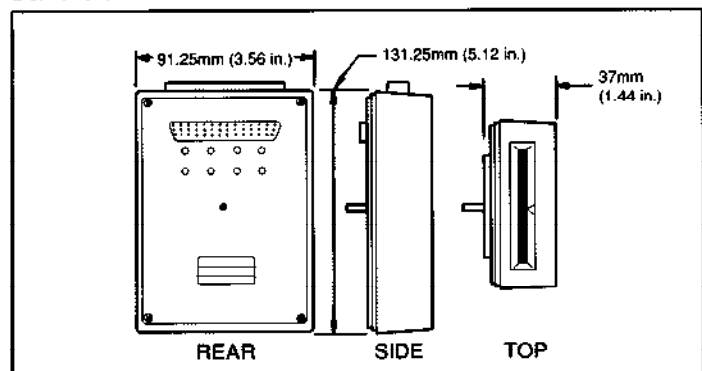

### HP 85700A Memory Card

Memory type and size: CMOS, 32K-byte battery-backed RAM

Battery: Lithium, 3V nominal, commercial part no. CR 2016

Battery life: 1 year; typically 5 years

Operating Temperature: 0° C to +60° C

Storage Temperature (Data Retention): -20° C to +60° C

Size (mm): 54 wide, 86 long, 2.4 thick nominal

Weight: 21 grams with battery nominal

### ORDERING INFORMATION

HP 85620A Mass Memory Module  
(includes one blank 32K-byte RAM  
memory card with battery)

Option 910: Extra manual

HP 85700A Blank 32K-byte RAM memory  
card with battery

### Associated Products and Accessories:

HP 8562A Spectrum Analyzer (1 kHz-22 GHz)

Option 026: Extended Frequency Coverage  
to 26.5 GHz

HP 8562B Spectrum Analyzer (unpreselected)

HP 8561A Spectrum Analyzer (1 kHz to 6.5 GHz)

HP 85901A Portable AC Power Source

HP 85710A Digital Radio Personality

HP 10833A/B/C/C HP-IB Cables

HP 3630A Paint Jet Printer (option 002)

HP 2225A Think Jet Printer

HP 7440A Color Pro Plotter (option 002)

HP 9000 Series 300 Technical Computer

For more information, call your local HP sales office listed in your telephone directory or an HP regional office listed below for the location of your nearest sales office.

#### United States:

Hewlett-Packard Co., 4 Choke Cherry Rd., Rockville, MD. 20850

Hewlett-Packard Co., 5201 Tollview Dr., Rolling Meadows, IL. 60008

Hewlett-Packard Co., 5161 Lankershim Blvd., No. Hollywood, CA., 91601

Hewlett-Packard Co., 2015 South Park Place, Atlanta, GA., 30339

Canada: Hewlett-Packard Ltd., 6877 Goreway Dr., Mississauga, Ontario L4V1M8

Australia/New Zealand: Hewlett-Packard Australia Ltd., 31-41 Joseph St. Blackburn, Victoria 3130,  
Melbourne, Australia

Europe/Africa/Middle East: Hewlett-Packard S.A., Central Mailing Dept., P.O. Box 529,  
1180 AM Amstelveen, The Netherlands

Far East: Hewlett-Packard Asia Ltd., 22/F Bond Centre, West Tower, 89 Queensway, Central, Hong Kong

Japan: Yokogawa-Hewlett-Packard Ltd., 29-21, Takaido-Higashi 3-chome, Suginamio-ku, Tokyo 168

Latin America: Latin American Region Headquarters, Monte Pelvoux Nbr. 111, Lomas de Chapultepec, 11000  
Mexico, D.F. Mexico

Data Subject to Change  
September 1, 1988