

Introduction

Precise, high resolution, on-wafer S-parameter measurements at frequencies up to 26.5 GHz can be made using the HP 8510 network analyzer and Cascade Microtech¹ wafer probes. Microwave wafer probing allows immediate evaluation for device characterization and selection before dicing the wafer and packaging. It is especially useful for rapid, on-wafer testing of discrete devices, and MMICs.

The ability to calibrate on wafer and make real-time error-corrected measurements with the HP 8510 are the principle advantages of this system. The speed provided by this system allows for in-process monitoring of key device model parameters while on-wafer calibration provides the accuracy necessary for incoming inspection or final test applications.

This note describes the basic test setup, operating procedure, and expected performance of this on-wafer measurement system. In particular, on-wafer calibration, equipment selection, and example device measurements will be shown.

¹ Cascade Microtech, Inc.
P.O. Box 2015
Beaverton, Oregon 97075
Telephone (503) 626-8245

All inquiries regarding performance specifications, warranties and ordering procedures for the Cascade Microtech wafer probing equipment should be directed to Cascade Microtech.

System Equipment Requirements

Both the interconnections between the HP 8510 network analyzer and Cascade Microtech wafer probe system, and the procedure for making on-wafer measurements are quite simple.

Figure 1 is a system block diagram and typical equipment list for the wafer probe system. This basic test setup includes a wafer probe station, the HP 8510 network analyzer system and a bias supply. The wafer probe station includes the microwave probes which serve as the coaxial to on-wafer bond pad adapter.

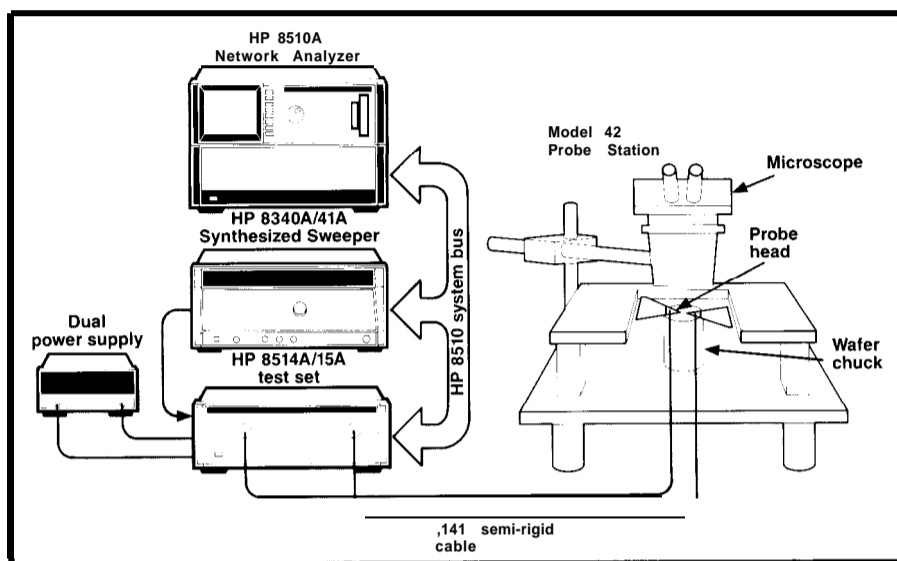

Figure 1 System Block Diagram and Equipment List

Microwave Network Analyzer System

HP 8510A Network Analyzer

Test Sets²

HP 8515A S-Parameter Test Set
(45 MHz to 26.5 GHz)

HP 8514A S-Parameter Test Set
(500 MHz to 18 GHz)
(HP Part Number 1250-1747
7mm to 3.5mm(f)
Adapter, 2 required)

RF Sources

HP 8340A Synthesized Sweeper
(10 MHz to 26.5 GHz)

(Option 005 recommended)

HP 8341A Synthesized Sweeper
(10 MHz to 20 GHz)

(Option 005 recommended)

HP 83508 Sweep Oscillator
Mainframe with HP 835XX
Series RF Plug-in

Test Set Return Cables

.141" Semirigid Coaxial Cables
(two cables of equal length –
provided by user)³

DC Bias Supplies⁴

HP 8717B Transistor Bias Supply
Manual/Bench Power Supplies

Model 42 Manual Power Station

(Includes 8 Microwave Probe
Heads, 2 Impedance Standard
Substrates and a microscope)

²S-parameter test sets are required for real-time, full two-port error correction. Reflection/Transmission test sets require device (and bias) reversal in order to measure all four S-parameters.

³Flexible cables may be used, however, movement of the cables should be minimized during operation. Test Set reference links should be selected to phase balance the test and reference channels.

⁴DC bias may also be provided through the HP 4145A semiconductor parameter analyzer or the HP 4141B DC source/monitor, which is part of the HP 4062A semiconductor/parametric system.

Selection of the RF source and test set will depend on the frequency range and stability requirements of the device under test. Any DC bias supply can be used, provided that the bias does not exceed the limits of the bias tees or probes.

One or both of the HP 8510 test set measurement ports are connected through semi-rigid cables to the microwave probe head coaxial connectors. Other coaxial cables that exhibit stable amplitude and phase response with cable flexure, may also be used.

Cascade Microtech provides the equipment to handle the special mechanical requirements of wafer probing at microwave frequencies. Systems which incorporate microwave probe heads are available in three different configurations.

1. A complete manual probe station – Model 42.
2. Integrated as part of a standard autoprober top plate – Model 54 or Model 64.
3. Integrated in a fixed probe card designed to fit standard manual or automatic probe stations – Series 1000 and Series 2000.

For the purpose of this note, the focus will be limited to the Model 42 manual probe station.

The Model 42 is a manual laboratory wafer and chip probe station having reconfigurable footprint capability. (Footprint refers to the contact pattern of the test device.) Up to four sides of a device can be probed at frequencies up to 26.5 GHz. Various probe head styles with a range of contact spacings are available for convenient footprint reconfiguration to different device pad layouts. Complete ordering information for the manual probe station, the autoprober top plate and the fixed footprint probe cards can be found in the wafer probing equipment data sheet which is available from Cascade Microtech.

Figure 2 (a) Microwave probe head
(b) Enlarged view of probe tip contacting wafer including typical dimensions

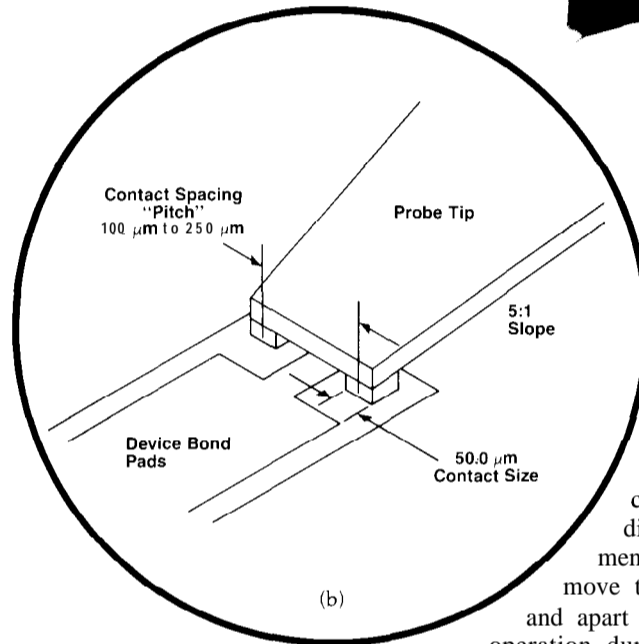
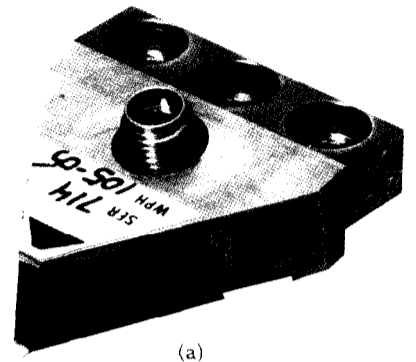

When using the probes on the manual (Model 42) or automatic (Model 54 or 64) probe stations, each probe head can be individually adjusted in X, Y and Z axes. The key advantage over probe cards is that new footprints can be configured for each new die. Further, this adjustment allows the user to move the probe heads together and apart which is a desirable operation during the calibration process.

The microwave probe head design incorporates coplanar transmission line which brings 50 ohm line characteristic impedance to the device bond pads on a chip or wafer. The coplanar transmission line spacing is scaled from the separation at the coaxial connector down to a 100μm to 250μm pitch (center-to-center contact spacing). A microwave probe head and typical probe tip dimensions are shown in Figure 2. The probe tip contacts physically touch the pads of the test device about 10μm back from the visible edge of the contacts.

The measurement calibration standards are provided on a dielectric substrate called the Impedance Standard Substrate (ISS). The Impedance Standard Substrate is a standard accessory of the Cascade microwave probing fixtures and provides all the necessary elements to calibrate and check the resultant error-corrected performance at the probe tips. Calibration standards, such as short circuits, through (delay) transmission lines, and matched loads, are provided on the ISS. Check (verification) devices such as resistive elements, capacitors and inductors are also provided on the ISS. Some of these elements are shown in Figure 3.

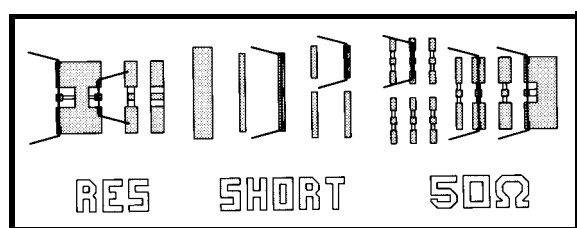

Figure 3 Enlarged portion of the Impedance Standard Substrate, shown with outlines of probe heads as they would be positioned for contacting.

Typical Measurement Procedure

The flow diagram shown in Figure 4 represents a typical measurement procedure for using an HP 8510 network analyzer and Cascade Model 42 probe station. Due to the precise and fragile nature of the wafer probe heads, the detailed procedure contained in the Cascade probe station operating manual should be followed when making an actual measurement.

The operating procedure, which is outlined in the flow diagram, involves hardware configuration and adjustment, system calibration and verification, and finally device measurement.

The system hardware and interconnections are shown in Figure 1. Microwave probe heads are selected to match the contact configuration of the test devices and installed in accordance with the Cascade Microtech operating manual instructions. Probe head selection will be considered later in this note.

Measurement calibration of a network analyzer is a process of measuring a set of devices with known characteristics. These devices, called standards, provide the measurement reference which is the basis of error-correction.

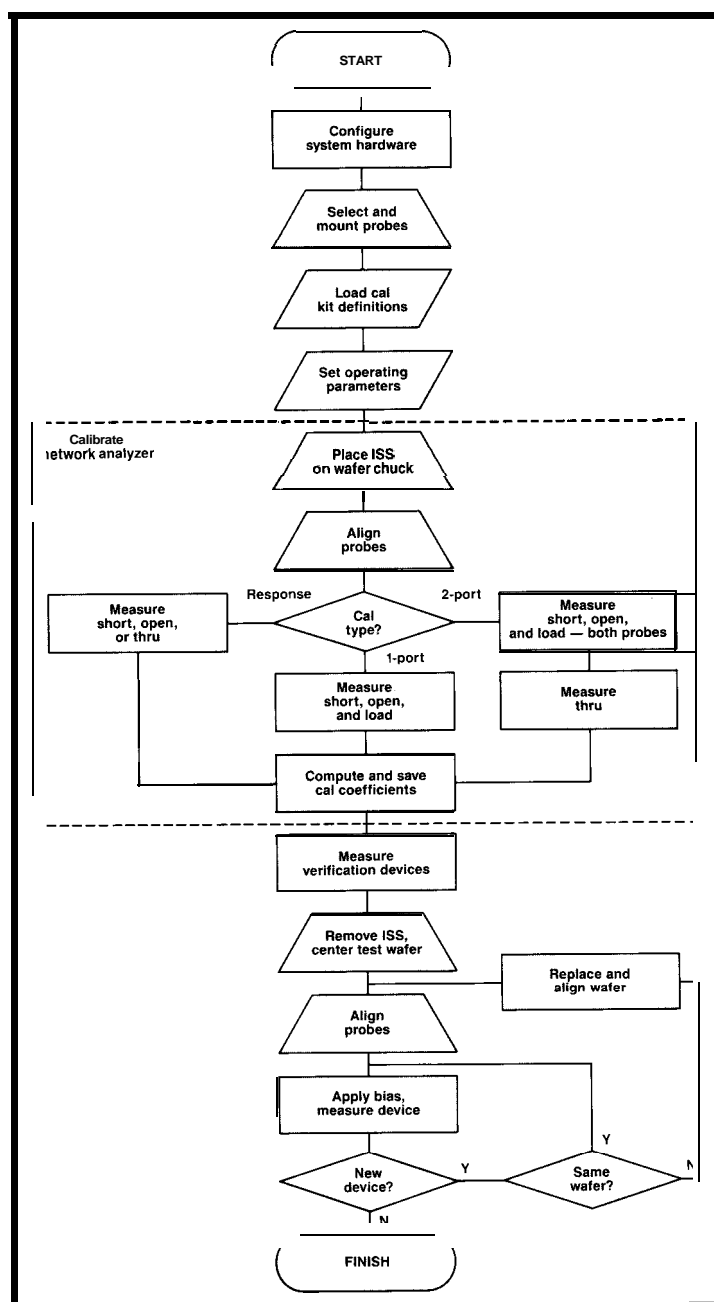

Figure 4 Flow diagram for a typical measurement of an on-wafer device using the Cascade Microtech Model 42 manual probe Station and the HP 8510 network analyzer system.

By measuring these known devices, we can determine the response of the connecting hardware. Once the connecting hardware has been characterized, its effects can be removed from subsequent measurements.

Calibration Kit definitions for the standards on the ISS are entered into the HP 8510 by the procedure listed in the appendix. The user then selects the desired operating parameters such as frequency, and number of data points, through the HP 8510. Once these parameters are set, a measurement calibration of the microwave probes is then performed.

Before making contact with on-wafer devices, each probe tip must be positioned for planarity with the top surface of the wafer, using the X,Y and Z axis adjustments on the probe station. The microscope is used to visually locate the on-wafer test device and the wafer chuck is used to position the contact pads under the probe tips. The Z-axis adjustment is used to bring the probe tips down onto the device pads. Contact is verified visually. Note: Once the probe tip positions are adjusted for planarity, the Z-lever is used to raise all the probe tips a fixed distance above the wafer. To measure other devices on the same wafer, locate the next device by moving the wafer chuck, and then make contact by lowering the Z-lever.

After the measurement calibration has been completed, the calibration coefficients are automatically computed by the HP 8510. The set of calibration coefficients are then saved in the HP 8510's nonvolatile memory.

Before measuring a test device, the accuracy of the calibration should be checked. A set of verification devices, also on the ISS, should be measured. Specified measurement performance is noted in the Model 42 operating manual.

When the probes are in contact with the test device, DC bias can then be applied through the test set or external bias tee inputs. At this point the S-parameters of the device can be measured.

Example Measurements

Evaluating devices and circuits while they are still on the wafer can reduce manufacturing costs by testing earlier in the production process. Using the HP 8510 with calibrated wafer probes, accurate S-parameter measurements of discrete devices and MMICs can be made before packaging the individual devices.

Let's take a look at some typical device measurements that can be made with the HP 8510 and the Cascade Microtech probes.

Figure 5 shows the measured data for some of the verification devices on the ISS from 131 MHz to 26.5 GHz. The microwave measurement of the 10, 25 and 250 ohm resistors on the ISS correspond well to their DC resistance values. The measurement of the 0.5nH inductor and inter-digitated capacitor show resonance-free, lumped element characteristics with a reflection coefficient less than one.

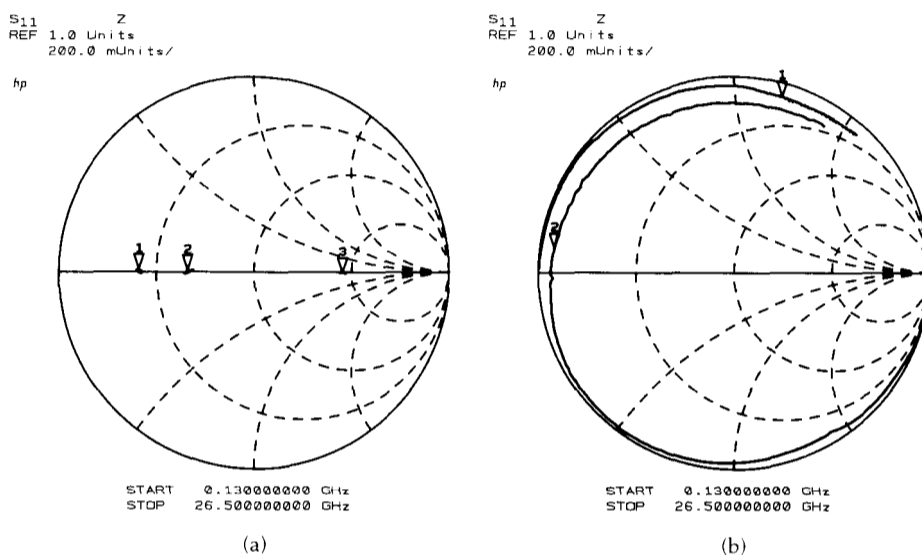

Figure 5 (a) Impedance measurement of 10 ohm (#1), 25 ohm (#2), and 125 ohm (#3) resistors. (b) Impedance measurement of .5 nH inductor (#1) and interdigitated capacitor (#2).

Current design methods rely heavily on simulating circuits via computer programs that, in turn, include numerical models of real devices. Properly designed models are based on accurate device measurements. The utility of these models extends from process control to simulation of completed circuits.

To illustrate the correlation between numerical models and accurate device measurements, consider the following simple device. Figure 6 shows the response of a MESFET gate diode at various forward voltages (with open drain) after a one-port calibration. A simple diode model for this device, shown in Figure 7, would include junction capacitance, junction resistance, diode series resistance and inductance from the pads into the device. The process of deriving the numerical values for these parameters uses a series of measurements.

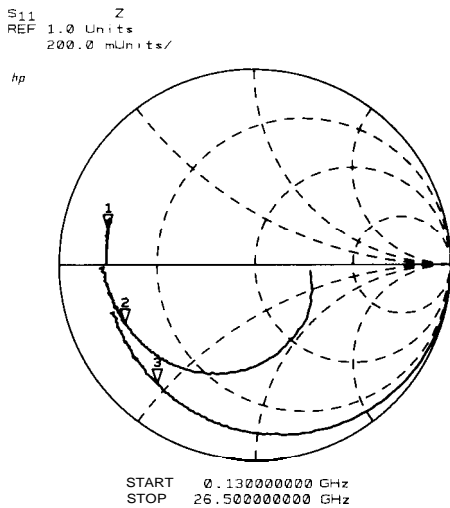

Figure 6 Impedance measurement of the gate-source diode of a GaAs FET, with open drain, at 3 different DC bias conditions: $V_{gs} = 1.0$ V (#1), $V_{gs} = 0.6$ V (#2), $V_{gs} = 0.0$ V (#3).

When the diode is fully forward biased (Figure 6, trace #1), the diode junction resistance (R_j) becomes negligible. The diode impedance is measured to be 6.8 ohms in series with 44 pH. It should be noted that the incremental resistance of this diode at DC is measured to be 6.8 ohms.

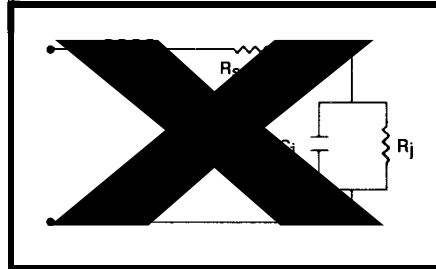

Figure 7 Simple diode model

When the diode is un-biased (Figure 6, trace #3), the junction resistance becomes large. The measured diode impedance is equivalent to the junction capacitance in series with the diode series resistance (6.8 ohms) and inductance (44 pH). For this diode the junction capacitance is calculated to be 0.4 pF. Since the junction diode resistance varies as a function of bias, it is computed for each operating bias point as the difference between the incremental resistance (measured at DC) and the diode series resistance (6.8 ohms). Based on the measure-

ments shown in Figure 6, numeric values for the elements can be determined. It is significant to note that the device's modeled performance matches the performance as measured with the microwave probes and the HP 8510.

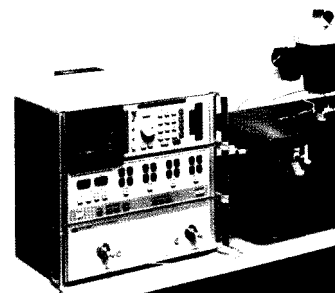

Figure 8 shows the insertion loss measurement of a 10 dB verification attenuator on the ISS, after a two-port calibration. The measured attenuation value is 10 ± 0.1 dB.

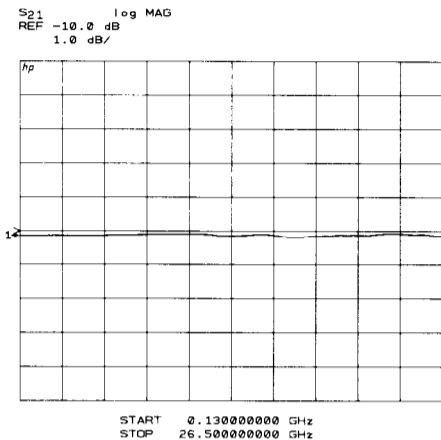

Figure 8 Attenuation measurement of a 10 dB on-wafer verification attenuator.

A two port measurement of a $1 \times 300 \mu\text{m}$ GaAs FET is shown in Figure 9. Note that the measured frequency response of the FET is smooth and does not exhibit any local resonances. This type of response then can be characterized with a simple lumped-element device model. Complex responses indicate that a number of different elements (i.e., the device, the package, the bond wires) are interacting and as a result will require a more complex model.

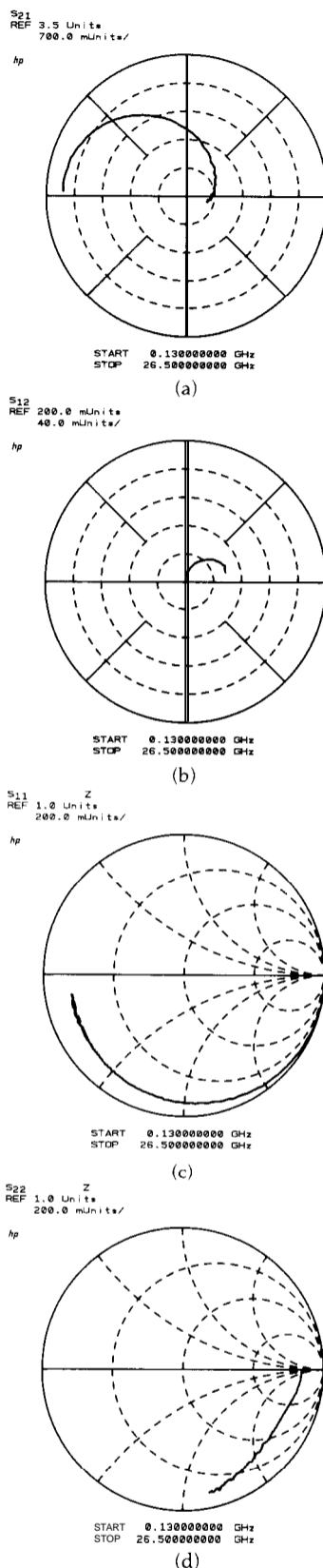

Figure 9 S-parameter measurement of a $1 \times 300 \mu\text{m}$ GaAs FET using Cascade Microtech probes, (a) S_{21} (b) S_{12} (c) S_{11} (d) S_{22} .

The measurement of an MMIC, a 2 to 20 GHz single-stage broadband amplifier, is shown in Figure 10. The measured voltage gain of the device is greater than 5 dB from 2 to 20 GHz.

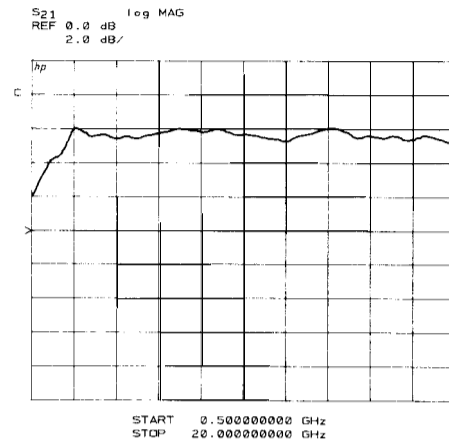

Figure 10 Voltage gain measurement of an on-wafer single stage amplifier MMIC from .5 to 20.0 GHz.

An example design application may be to produce a broadband amplifier with 20 dB minimum gain using five cascaded single-stage devices. By measuring the microwave response of each on-wafer device, the designer can select and package only those devices that exhibit acceptable gain. Accurate on-wafer measurements allow the designer to predict the response of the completed component with a high degree of confidence.

Measurement Considerations

In these next sections we will consider some of the factors which may affect the accuracy of on-wafer network analyzer measurements. Measurement calibration is used to remove some of the systematic errors present in the test setup. Further consideration will be given to the type of probe head used and how the various probe head styles can change the measured data.

Measurement Calibration

In any measurement system, the measured data will deviate from the actual data because of imperfections in the instrumentation. The difference between the actual and the measured data must be considered an error. With an HP 8510 network analyzer, built-in error correction can reduce systematic errors such as test port mismatches and reference to test channel tracking. In a static measurement environment, leakage signals between test and reference channels can also be effectively removed.

On-wafer measurements present a different set of errors. The close spacing between the microwave probes makes it difficult to maintain a high degree of isolation between the input and output. The type of device measured on wafer often is not always a simple two-port. A three-port device such as a microwave transistor is measured by grounding the common lead. However, the series inductance of the common lead will affect the measured impedance. Finally, it may also be difficult to make repeatable on-wafer contacts, if only due to the size of the device contact pads.

Let's look at how these errors can affect on-wafer measurements, including how certain errors are dependent on the hardware configuration.

Probe Head Configurations

The probe tip calibration standards, which are on the Impedance Standard Substrate (ISS), are shown in Figure 11. Note that all calibration and verification devices for each of the probe head styles are available on a single substrate. The type and dimensions of the calibration standard used must correspond to the contact configuration of the probe head and bond pads of the test device.

The designations shown in Figure 11 on the ISS refer to these probe head styles. Some of the designations are:
S1-G: Signal-Ground
G-S1: Ground-Signal
G-S1-G: Ground-Signal-Ground
S1-G-S2: Signal(l)-Ground-Signal@

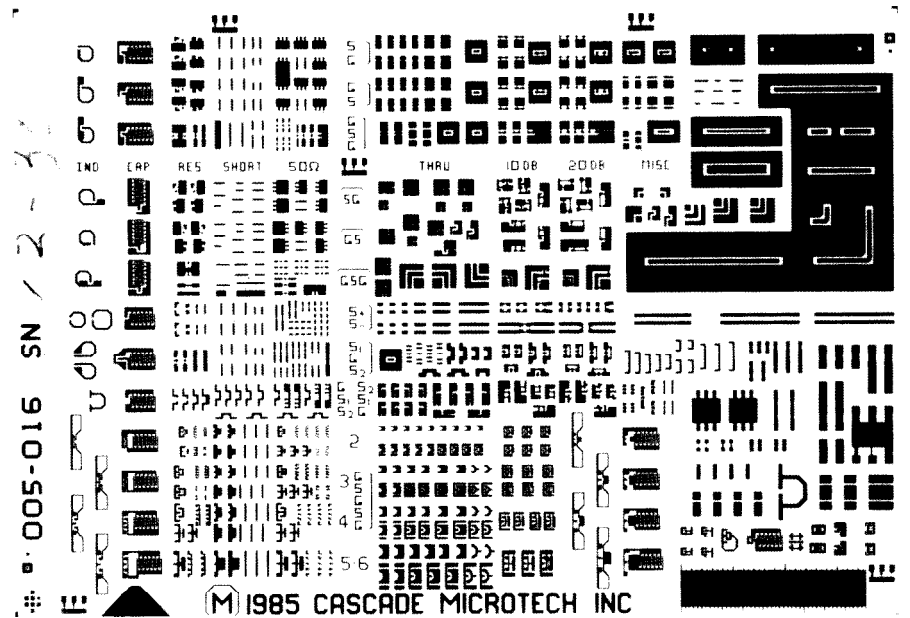

Figure 11 Enlarged view of the Impedance Standard Substrate (ISS). The on-wafer devices shown are used to calibrate at the probe head to wafer interface.

Note: Coplanar probing, using the probes described here, require that the signal and ground connections are on top of the wafer or chip layout. Further, the pad layouts that can be measured are limited to the configurations described in Figure 12.

Three of the probe styles recommended for use with a microwave network analyzer are the SI-G, G-S1 and G-S1-G probe styles and are shown in Figure 12. The various probe head styles and configurations are described in more detail in the Cascade Microtech data sheet.

In the measurement of on-wafer devices such as microwave transistors and MMICs, the choice of probe head style can have an effect on the measurement results. While the single ground probes are generally easier to use since only two on-wafer contacts are needed, there is a compromise in performance due to higher crosstalk and greater common lead effects. A dual ground probe provides a higher degree of shielding between probes, but also requires three on-wafer contacts, two parallel grounds and a signal line. Also, a test device can be accessed with reduced ground lead inductance if it has two parallel ground contacts. Considering these potential sources of error, the performance of each of these recommended probe styles will be evaluated in the following sections.

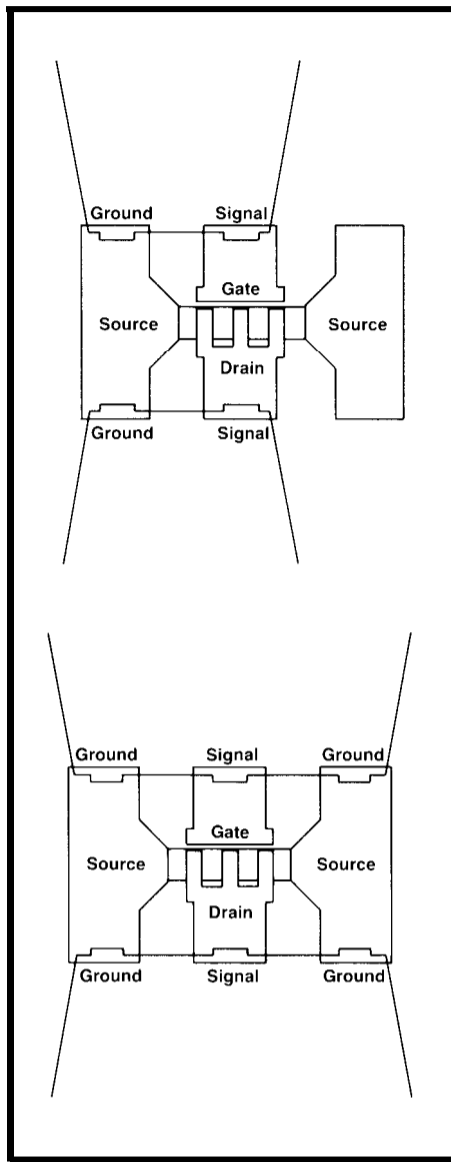

Figure 12 Recommended probe and pad configuration for making probed on-wafer measurements with a network analyzer:
(a) Signal-ground (b) Ground-signal-ground

Repeatability

A limiting factor in the accuracy of any measurement system is repeatability. Connection repeatability, for the wafer probe system, is dependent on the stability of the coaxial cables connecting the test set to the probe heads, the stability of the probes themselves and the consistency of probe-to-wafer contacts.

The phase stability of the test port cables is particularly important at the high end of the operating frequency range. However, once the probes are aligned for measurement, there is only slight flexing of the coaxial cables, therefore, semi-rigid cables can be used and should provide a high degree of stability.

Note: Flexible cables may be used provided that the movement of the cables is minimized during operation. The use of flexible cables will reduce stress on the probe head connectors.

The rigid probe head design maintains stability within the probe head as well as provides the ability to exert consistent pressure at the probe tips. The ability to make a repeatable connection to the contact pads of an on-wafer device, is highly dependent on the planarity of the wafer with respect to the probe tips. Since the wafer is not perfectly flat, the probe tips will exert varied degrees of pressure at each contact point. Consequently, it is easier to make a good, repeatable connection with a probe tip that only has two contacts (signal-ground, ground-signal) than with a three-contact probe (ground-signal-ground).

Figure 13 shows the typical repeatability with a ground-signal probe on a short circuit standard. Trace #1 indicates repeatability of the instrumentation as re-measurement of the short with contact unbroken. Trace #2 is a measurement of typical repeatability when probe contact is broken and reconnected. A third measurement represents the contact repeatability when contact is broken, the probe shifted by 1 mil and then reconnected.

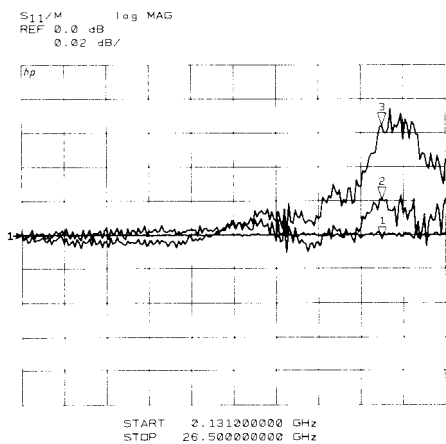

Figure 13 Measurement of typical repeatability using a ground-signal probe. Three S_{11} measurements of an on-wafer short circuit (referenced to an initial measurement stored in the memory of the HP 8510) are shown: (#1) System noise floor, contact unbroken between stored and current measurement, (#2) on-wafer contact broken by raising probe and then recontacting, (#3) on-wafer contact broken by raising probe shifting laterally 1 mil and then recontacting.

Crosstalk/Isolation

The two port calibration procedure for this system normally does not include a measurement of isolation between probe heads. The isolation, or crosstalk between the input probe head and the output probe head, will change significantly between calibration and measurement. This is due to the position of the probe heads relative to each other and the wafer and wafer chuck.

Isolation characteristically will decrease with higher frequency and closer spacing (between probes). Dual ground probes exhibit greater isolation by providing ground planes on both sides of the signal line. Figure 14 is an example measurement of system isolation (S_{12}) with ground-signal-ground probes. Isolation levels are measured in three positions: both probes contacting shorts and separated by 4 mils (-42 dB minimum), both probes in air separated by 8 mils (-50 dB minimum), and both probes in air separated by 100 mils (bottom trace, -52 dB minimum). The single ground probe head pairs will exhibit about 15 dB more transmission in each of these cases.

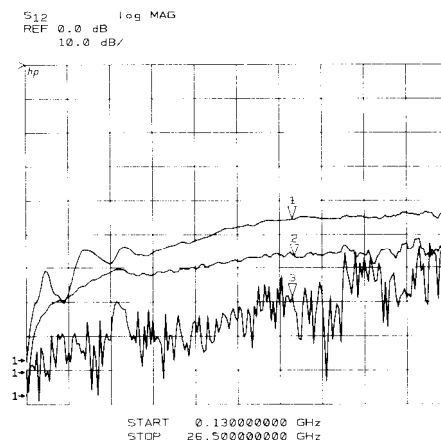

Figure 14 Measurement of typical isolation using ground-signal-ground probes. Measured isolation levels are shown for: (#1) both probes contacting short circuits separated by 4 mils, (#2) both probes in air separated by 8 mils, (#3) both probes in air separated by 100 mils.

Typically, probe crosstalk for the ground-signal-ground probe heads will be greater than 40 dB and 20 dB for a pair of single ground probes.

Common Lead Effects

Figure 15 shows the measurement of 10 dB verification attenuators on the ISS. One measurement was made with a pair of single ground microwave probes and the other measurement

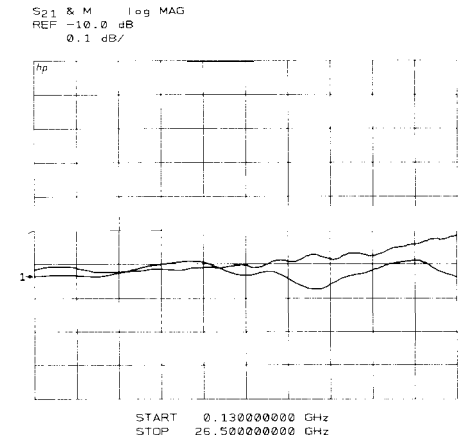

Figure 15 Attenuation measurements of 10 dB on-wafer verification devices using: (#1) a pair of single ground probes, (#2) a pair of dual ground probes.

with a pair of dual ground microwave probes. The measured attenuation using each configuration tracks closely. This type of passive two port device can be measured quite accurately since the transmitted signals are well above the crosstalk signal levels. However, in addition to repeatability and isolation, the measurement of three lead devices such as transistors, present an additional potential source of error. A measurement of a $1 \times 300 \mu\text{m}$ GaAs FET with a pair of single ground probes and a pair of dual ground probes is shown in Figure 16. There is significant discrepancy in the reverse transmission path (S_{12}) measurements when measured with the two different probe styles.

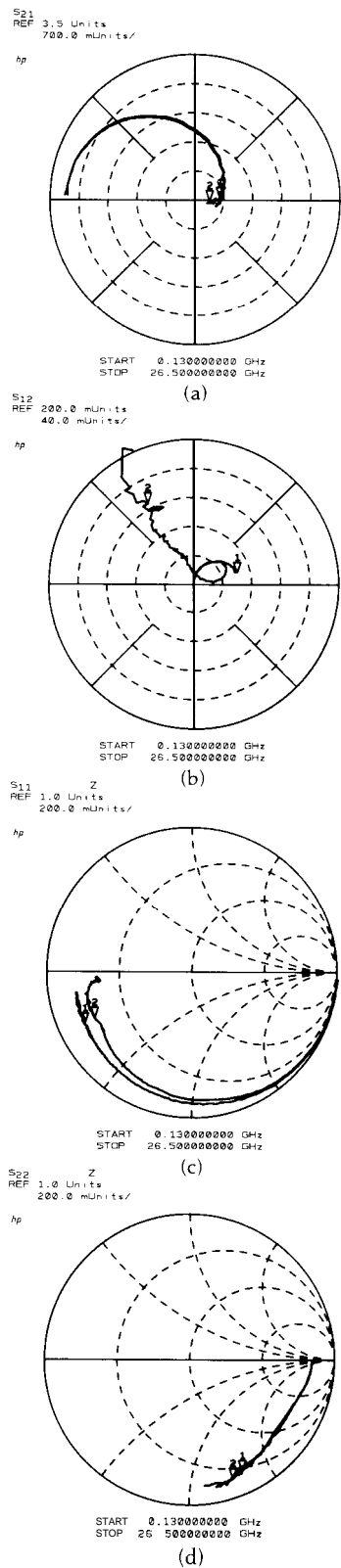
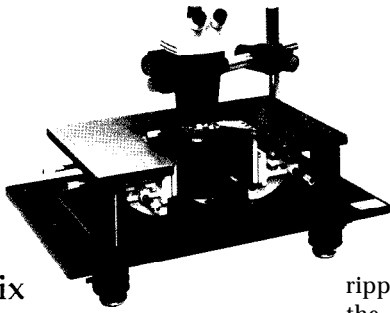

Figure 16 S-parameter measurements of a $1 \times 300 \mu\text{m}$ GaAs FET using: (#1) a pair of dual ground probes, (#2) a pair of single ground probes as shown in Figure 11. (a) S_{21} (b) S_{12} (c) S_{11} (d) S_{22} .

For a common-source FET, the source connection metal acts as a small inductance. The inductance of the grounded single source contact can become large in comparison to the signal level through the S_{12} path. For example, 60 pH of source inductance at 18 GHz is equivalent to about 7 ohms of reactive impedance or -24 dB loss. Therefore, in order to measure signal levels below -24 dB, the source inductance must be reduced or calibrated out. The inductance of the source connection is effectively reduced when using dual ground probes since the source inductance is connected in parallel. A more complex error-correction scheme than is currently available with the HP 8510 would be needed to remove source lead inductance through calibration.

Therefore, the two sets of measurements shown in Figure 15, made with one or two source connections, should be different. Either style of probe accurately measures the impedance presented to its contacts, but by having two source connections in parallel, the inductance of these contacts is reduced.



Appendix

ISS Calibration Standards and Entry Procedure for the HP 8510

The calibration kit definitions for the ISS devices are supplied by Cascade Microtech. Short circuits, 50 ohm loads and through lines for all probe styles are contained on the ISS.

The 50 ohm termination standards, which are used as fixed loads, are measured and trimmed at DC. Although these terminations have some series inductance and shunt capacitance, only the real resistance is used in the standard definition.

The short circuit standard is a bar of conductor 2 mils wide that is just large enough to connect the probe contacts. The series inductance of the short is minimal, but may be considered if a higher degree of precision is required.

The open circuit standard is obtained simply by lifting the probe tips at least 10 mils into the air. The appropriate setting for the open circuit capacitance is empirically determined for each probe head (by Cascade Microtech) and typically falls in the range of -10 to -30 fF. The capacitance between the probe contacts and the wafer chuck will actually increase when the probes are lowered onto the wafer. A negative value is used to compensate for the change in capacitance which occurs between calibration and measurement. An incorrect open circuit capacitance value in the calibration kit will cause the measured reflection coefficient of a high-Q inductor or capacitor to have a magnitude greater than one.

The capacitance value is determined by iterating the capacitance for an open standard while measuring a short coplanar stub, which serves as an offset open circuit. Incorrect capacitance values will cause periodic

ripple in the measured reflection of the stub, provided that the length of the stub is greater than one half the propagation velocity divided by the bandwidth. When the capacitance value is correct, the magnitude of the measured reflection coefficient of the offset open circuit will steadily decrease with frequency (due to skin effect loss).

The through connection for two-port calibrations uses a minimum length coplanar line that connects the ground and signal contacts of the two probe heads together. A practical minimum distance between the tips is about 5 mils, or about 1 picosecond of delay on alumina. The offset delay of the through is adjusted to 1 ps using the calibration kit definition procedure.

The HP 8510 calibration kit parameters are listed in Table 1 and can be entered using the following procedure.

Before entering new calibration kit definitions into the HP 8510, store the existing calibration kits on the Data Storage Cassette by performing the following key sequence: TAPE, STORE, CAL KIT 1-2, #1, FILE #1 (or any unused FILE).

Repeat for Cal Kit #2, if desired.

To enter the new calibration kit definitions, perform the following HP 8510 front panel key sequence:

1. Select CAL menu, MORE.
2. Select MODIFY CAL 1 or MODIFY CAL 2 depending on the register to be modified.
3. Define the open circuit standard as follows. (See the corresponding probe head data sheet supplied by Cascade Microtech with each probe head. Note that if the open circuit capacitance is different for the two probe heads used, another open standard must be defined. Also, the standards must be assigned to the appropriate class, S_{11A} or S_{22A} .)

```

DEFINE STANDARD,
1, xl, OPEN,
    CO, -15, xl (for -15fF)
    C1, 0, xl
    c2, 0, x2
    c3, 0, x3
SPECIFY OFFSET,
    OFFSET DELAY, 0, xl
    OFFSET LOSS, 0, xl
    OFFSET ZO, 50, xl
    MINIMUM FREQUENCY, 0, xl
    MAXIMUM FREQUENCY, 999, G/n
    COAX, STD OFFSET DONE
LABEL STD, ERASE TITLE,
    select O,P,E,N, SPACE,-,1,5,
    TITLE DONE
STD DONE (DEFINED)

```

4. Define the remaining standards as follows.

```

DEFINE STANDARD,
2, xl, SHORT
SPECIFY OFFSET,
    OFFSET DELAY, 0, xl
    OFFSET LOSS, 0, xl
    OFFSET ZO, 50, xl
    MINIMUM FREQUENCY, 0, xl
    MAXIMUM FREQUENCY, 999, G/n
    COAX, STD OFFSET DONE
LABEL STD, ERASE TITLE,
    select S, H, 0, R, T,
    TITLE DONE
STD DONE (DEFINED)
DEFINE STANDARD,
3, xl, LOAD
SPECIFY OFFSET,
    OFFSET DELAY, 0, xl
    OFFSET LOSS, 0, xl
    OFFSET ZO, 50, xl
    MINIMUM FREQUENCY, 0, xl
    MAXIMUM FREQUENCY, 999, G/n
    COAX, STD OFFSET DONE
LABEL STD, ERASE TITLE,
    select L, 0, A, D
    TITLE DONE
STD DONE (DEFINED)
DEFINE STANDARD,
4, xl, THRU
SPECIFY OFFSET,
    OFFSET DELAY, .001, G/n
    OFFSET LOSS, 0, xl
    OFFSET ZO, 50, xl
    MINIMUM FREQUENCY, 0, xl
    MAXIMUM FREQUENCY, 999, G/n
    COAX, STD OFFSET DONE

```

LABEL STD, ERASE TITLE,
 select T, H, R, U
 TITLE DONE
 STD DONE (DEFINED)
 for 1 ps delay (minimum-length thru).
 For other lengths such as the through
 connection for a fixed foot print
 probe card, enter the appropriate
 delay and loss.

5. Assign the standards to the
 appropriate classes.

SPECIFY CLASS

- S11A, 1, xl,
- S11B, 2, xl,
- S11C, 3, xl,
- S22A, 1, xl,
- S22B, 2, xl,
- S22C, 3, xl,

MORE,

- FWD. TRANS., 4, xl,
- REV. TRANS., 4, xl,
- FWD. MATCH, 4, xl,
- REV. MATCH, 4, xl,
- RESPONSE, 4, xl,
- CLASS DONE (SPEC'D)

6. Label the classes. These names will
 appear in the calibration menu.

LABEL CLASS,

S11A, enter the title "OPEN - 15":
 LABEL DONE

(In this fashion the label reminds the
 user of the open capacitance value.)

S11B, enter "SHORT", LABEL DONE

S11C, enter "LOAD", LABEL DONE

S22A, enter "OPEN - 15": LABEL
 DONE

S22B, enter "SHORT", LABEL DONE

S22C, enter "LOAD", LABEL DONE

MORE,

FWD. TRANS., enter "THRU",
 LABEL DONE

REV. TRANS., enter "THRU",
 LABEL DONE

FWD. MATCH, enter "THRU",
 LABEL DONE

REV. MATCH, enter "THRU",
 LABEL DONE

RESPONSE, enter "THRU",
 LABEL DONE

LABEL DONE

7. Then label the kit.

LABEL KIT,

ERASE TITLE, R, F,
 SPACE, I', R, 0, B, E,
 TITLE DONE, KIT DONE
 (MODIFIED).

The kit is ready to be stored onto
 cassette now.

For the case when the only
 modification to the cal kit is to
 change the open capacitance value,
 use the following sequence.

CAL, MORE, MODIFY 1 or MODIFY 2,
 DEFINE STANDARD,

1, xl, OPEN, CO, (new value in ff), xl,
 STD DONE (DEFINED),

LABEL CLASS,

S11A, enter "OPEN XXX",
 where XXX is the new C value,
 LABEL DONE

LABEL CLASS,

S22A, enter "OPEN XXX",
 where XXX is the new C value,
 LABEL DONE

KIT DONE (MODIFIED)

Table 1 Calibration kit definitions for the
 devices on the Impedance Standard Substrate

CALIBRATION KIT RF PROBE													
TAPE FILE NUMBER													
STANDARD NO	TYPE	C0	C1	C2	C3	FIXED OR SLIDING	DELAY ps	LOSS dB	Z0 Ω	FREQUENCY (GHz)		COAX or WAVEGUIDE LABEL	
		x10 ⁻¹⁵ F	x10 ⁻²⁷ F/Hz	x10 ⁻³⁶ F/Hz	x10 ⁻⁴⁵ F/Hz					MINIMUM	MAXIMUM		
1	OPEN	-15	0	0	0			0	50	0	999	COAX	OPEN-IS
2	SHORT						0	0	50	0	999	COAX	SHORT
3	LOAD					FIXED	0	0	50	0	999	COAX	LOAD
4	THRU						.001	0	50	0	999	COAX	THRU

Standard Class Assignments

CALIBRATION KIT LABEL RF PROBE
 TAPE FILE NUMBER

	A	B	C	D	E	F	G	STANDARD CLASS LABEL
S ₁₁ A	1							OPEN -15
S ₁₁ B	2							SHORT
S ₁₁ C	3							LOAD
S ₂₂ A	1							OPEN -15
S ₂₂ B	2							SHORT
S ₂₂ C	3							LOAD
Forward Transmission	4							THRU
Reverse Transmission	4							THRU
Forward Match	4							THRU
Reverse Match	4							THRU
Frequency Response	4							THRU