

Errata

Title & Document Type: 786D / 787D / 788C Directional Detectors Operating and Service Manual

Manual Part Number: 00786-90001

Revision Date: May 1977

About this Manual

We've added this manual to the Agilent website in an effort to help you support your product. This manual provides the best information we could find. It may be incomplete or contain dated information, and the scan quality may not be ideal. If we find a better copy in the future, we will add it to the Agilent website.

HP References in this Manual

This manual may contain references to HP or Hewlett-Packard. Please note that Hewlett-Packard's former test and measurement, life sciences, and chemical analysis businesses are now part of Agilent Technologies. The HP XXXX referred to in this document is now the Agilent XXXX. For example, model number HP8648A is now model number Agilent 8648A. We have made no changes to this manual copy.

Support for Your Product

Agilent no longer sells or supports this product. You will find any other available product information on the Agilent Test & Measurement website:

www.agilent.com

Search for the model number of this product, and the resulting product page will guide you to any available information. Our service centers may be able to perform calibration if no repair parts are needed, but no other support from Agilent is available.



Agilent Technologies

HP 786D
HP 787D
HP 788C

OPERATING AND SERVICE MANUAL

786D

787D

788C

DIRECTIONAL DETECTORS

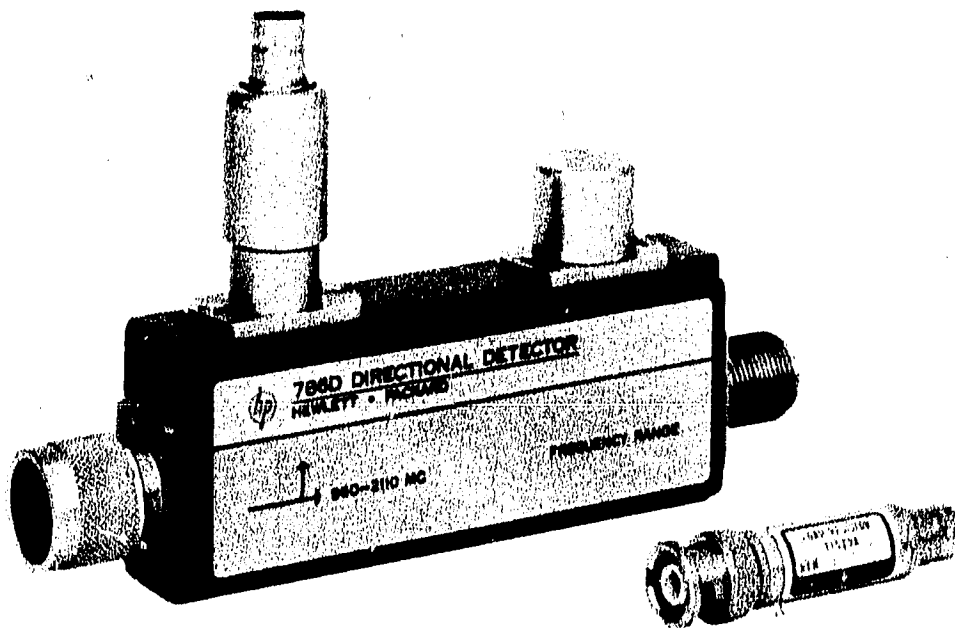

MAY 1977

HEWLETT **hp** PACKARD

HP 786D
HP 787D
HP 788C

1. INTRODUCTION.

2. The directional detector, a directional coupler with built-in crystal detector, is designed for use in coaxial systems over a relatively wide frequency range. Applications include closed-loop leveling, observation of RF envelope variation, and power monitoring. Output polarity of detected signal is normally negative, but positive output polarity is available as Option 03. The cover shows Model 786D with Option 02 Load Resistor, available when optimum conformance to square-law characteristics is required. Table 1 lists complete instrument specifications.

3. The directional detector and the optional square-law load (HP 11523A) are separately housed. This arrangement permits choice of directional detector operation for optimum square-law response for detected outputs of up to 50 mV (with the load attached) or maximum output sensitivity (without the load). For proper identification the directional detector carries the same serial number as the load. Always check that the serial number of the load and directional detector are identical.

4. The type N connectors on these directional detectors mate compatibly with connectors whose dimensions conform to MIL-C-39012 or MIL-C-71 (see Figure 2). In addition, the connector bodies are stainless steel for long wear.

5. PRECAUTIONS.

6. STATIC ELECTRICAL DAMAGE.

7. The maximum pulse rating for the detector element (diode) used in the directional detector is 0.1 erg of energy. A four-foot length of coaxial RG58/U cable, the equivalent of a 100-pF capacitor, when charged to 14 volts, is the equivalent of 0.1 erg of energy. Be certain that connecting cables are always connected to associated equipment and discharged before connecting to the detector output.

8. HANDLING DAMAGE.

9. **DO NOT HANDLE DETECTOR ELEMENT NEEDLESSLY.** Static electricity which builds up on the body, especially on cold, dry days, must never be allowed to discharge through the detector element. Avoid exposed leads to or from the detector output, since these are often touched accidentally. Refer to Paragraph 28 for proper precautions.

10. OPERATION.

11. The directional detector is useful as the sampling and detection device in closed-loop leveling setups as described in Paragraph 17. It can also be used as a calibrated power monitor by determining the correlation between detected output and main-line RF output levels, or for relative RF envelope observation with an oscilloscope. If the directional detector is to be permanently mounted for any application, refer to Figure 1, which illustrates the location of the four mounting holes and the general side dimensions. Before installing in any setup, the following should be considered:

a. The type N connectors are HP compatible type N connectors which are designed to mate with standard 50-ohm type N connectors. They mate with all other type N connectors except HP "precision" male connectors. Use adapters made from other type N connectors with "precision" connectors.

b. The detector element used is sensitive to either amplitude-modulated or continuous-wave (CW) RF power. If RF power is amplitude modulated at a 1000-Hz $\pm 2\%$ rate, the sensitive HP Model 415B or 415E (SWR Meter) can be used as the indicator. For CW detection, a dc milliammeter or millivoltmeter (with an input impedance of at least 100K ohms), such as the HP Model 425A Microvolt-Ammeter can be used as the indicator.

c. When using an oscilloscope to observe wave-shapes of rise times less than 5 μ sec, the coaxial cable connecting the detected output and the oscilloscope should be as short as possible and terminated with a shunting resistor. Ideally, this resistor should be 50 ohms to terminate the coaxial cable in its characteristic impedance. However, with 50 ohms, the video pulse may have too small an amplitude to drive some oscilloscopes. Typically, the required value is between 50 and 2000 ohms. The larger the resistance, the slower the observable rise time. Oscilloscopes ideal for this application are the HP Models 140A or 175A, depending upon required bandwidth.

d. A low-pass filter should be used in all applications of the directional detector where harmonic frequencies may be present.

12. SENSITIVITY CHARACTERISTICS.

13. The sensitivity characteristics of the directional detectors is well defined in two ranges of main line RF power output, a lower range extending up to 500 μ W (50 μ W for the 788C) and a higher range between 5 and 35 mW (0.5 and 3.5 mW for the 788C). In the lower range the ratio of detected output to main line RF power output (sensitivity), in microvolts per microwatt, is at least 4:1 (40:1 for the 788C). In the higher range, the ratio, in millivolts per milliwatt, is at least 2.85:1 (28.5:1 for the 788C). Between ranges, and beyond the higher range, sensitivity characteristics vary from detector element to detector element. Beyond the higher range sensitivity diminishes to a saturation level (a maximum detected output of 300 to 500 mV) where increased main line RF power produces no significant increase in detected output.

Table 1. Specifications

	786D	787D	788C
Frequency Range (GHz):	0.96 - 2.11	1.9 - 4.1	3.7 - 8.3
Frequency Response (dB): ¹	±0.2	±0.2	+0.3
Sensitivity with Respect to Power: Low Level ($\mu\text{V}/\mu\text{W}$ CW)	> 4	> 4	> 40
High Level (power in mW to produce 100 mV out)	≤ 35	≤ 35	≤ 3.5
Directivity (dB):	30	26	20
Equivalent Source Reflection Coefficient: ²	≤ 0.06 (1.13 SWR)	≤ 0.075 (1.16 SWR)	≤ 0.111 (1.25 SWR)
SWR:	1.15	1.15	1.20
Maximum Input (W, peak or average):	10	10	1
Approximate Insertion Loss (dB):	0.25	0.35	0.6
RF Connector Type: ³ Input: Type N (coaxial)	Male	Male	Male
Output: Type N (coaxial)	Female	Female	Female
Length: (in.)	6	4-7/8	4-7/8
(mm)	152	124	124
Weight: Net (lb)	1	3/4	3/4
(kg)	0.45	0.34	0.34
Shipping (lb)	2	2	2
(kg)	0.9	0.9	0.9
Nominal Coupling	20	20	10

¹ Includes coupler and detector variation with frequency as read on a meter calibrated for square-law detectors (e.g., HP 415E SWR Meter).

² The apparent reflection coefficient at the output of an RF generating system, using a directional detector in a closed-loop leveling system.

³ Type N connectors mate compatibly with connectors whose dimensions conform to MIL-C-39012 or MIL-C-71.

FOR ALL MODELS

Detector Output Impedance: 15 k Ω maximum
shunted by approximately 10 pF.

Detector Element: Supplied.

Noise: < 200 μV peak-to-peak with CW power applied to produce 100 mV output.

Detector Output Polarity: Negative.

Detector Output Connector: BNC female.

Options:

002 Furnished with load resistor for optimum square-law characteristics at 24°C (75°F), < ±0.5 dB variation from square law over a range of at least 30 dB from low level up to 50 mV peak output (working into external load > 75 k Ω); sensitivity typically 25% of that of the unloaded detector.

003 Positive polarity detector output, no additional charge.

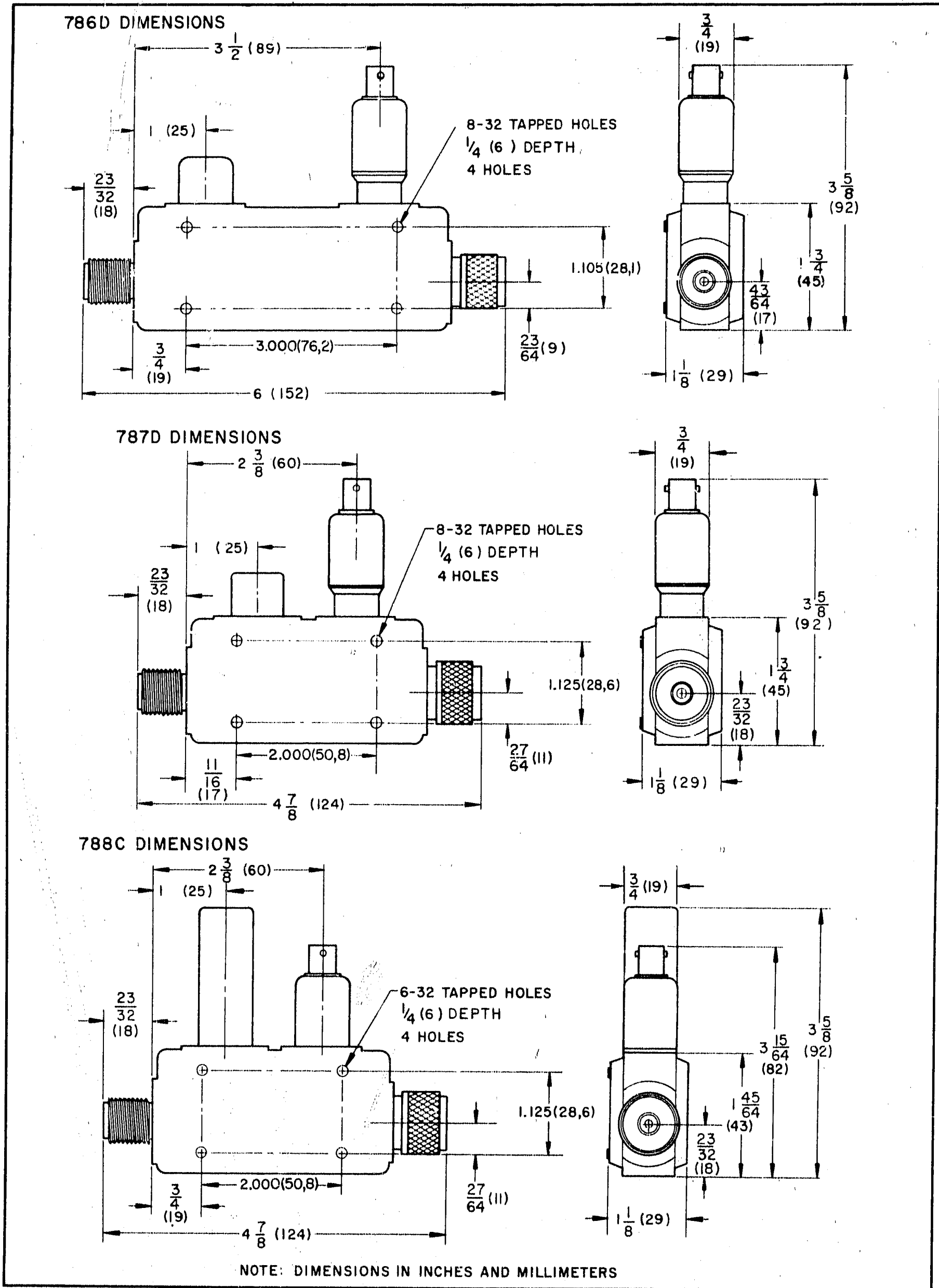

Figure 1. Outside Dimensions

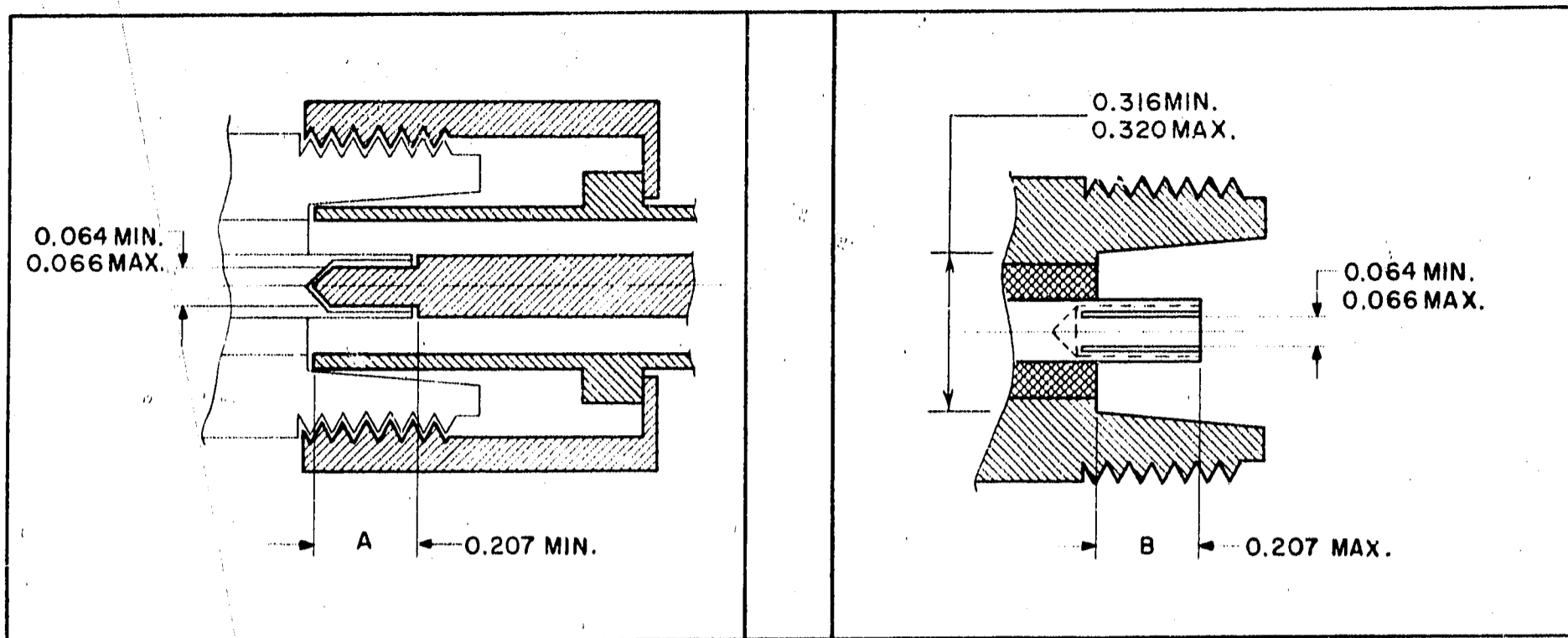

Figure 2. Type N Connector Dimensions

14. SQUARE-LAW LOADING.

15. The square-law load (HP 11523A) is selected for optimum response (minimum deviation from square law) at 24°C (75°F). Typically, detected output varies ± 0.3 dB from exact square law for values of output voltage between 5 mV and 50 mV. At higher temperatures output voltage vs input power deviation is more negative and at lower temperatures the opposite is true. The change with temperature is approximately 0.04 dB/°C. For example, a detected output which varies ± 0.3 dB from exact square law at 24°C would vary about -0.2 to +0.4 dB at 22°C (72°F).

16. CLOSED-LOOP LEVELING.

17. **TECHNIQUE.** The directional detector has a direct application in systems employing closed-loop leveling of an RF source. Any variation in the RF output level causes a proportional variation in the detected output level, and this is fed back to maintain a virtually constant RF output level. Generally, modern sweep oscillators, such as HP Model 690C/D sweep oscillators and 8690 series sweep oscillators, have built-in leveling amplifiers to amplify this signal and adjust RF output to maintain it at a constant level.

18. LEVELING POINT CONSIDERATIONS.

19. The closed leveling loop holds RF power constant at the point of RF sampling. Thus, if sampling is done

at the generator output connector, discontinuities in the transmission system between the connector and load cause uncontrollable power variations at the load. However, if the sampling point is located as near the load as possible, transmission system discontinuities are contained within the leveling loop and their effects are automatically compensated.

20. LEVELING VARIATIONS.

21. In leveling applications, the directional detector has considerable advantage over separate coupler and detector. With a perfectly matched load, the leveling variation due to the directional detector is equal to its frequency response. The corresponding figure for separate coupler and detector is the sum of (1) coupling variation, (2) frequency response of the detector, and (3) mismatch between the detector and auxiliary arm of the coupler. Typically this figure varies from about ± 0.5 to ± 1 dB, depending upon the frequency range.

22. In most cases, however, the directional detector looks into an imperfectly matched load. Here, the excellent source match of the directional detectors (due primarily to the high directivity) minimizes the effect of the reflected signal. Table 2 shows how small the worst-case leveling variations are when a load with an SWR of 2 is connected to the output of a directional detector.

Table 2. Worst-Case Effects on Leveling (in dB) Due to (1) 2:1 Load SWR Alone and (2) 2:1 Load SWR and Detector Frequency Response

	786D	787D	788C
2:1 Load	±0.16	±0.20	±0.31
2:1 Load Plus Freq. Response	±0.36	±0.40	±0.61

23. CALIBRATED POWER MONITOR.

24. The directional detector can also be used as a power monitor. By determining the correlation between the detected output and the main-line RF output levels the detected output can be calibrated directly in mV/mW and the directional detector can then be used to sample and indicate RF power levels at any point in a system. A power meter can be used to measure main-line RF output levels for calibration of the detected output. An oscilloscope, dc voltmeter, or SWR Meter can be used to measure the detected output.

25. MAINTENANCE.

26. Succeeding paragraphs give instructions for repair of the directional detector and the 11523A (Option 02) Load Resistor. Figure 3 illustrates the replaceable detector assembly for the 786D, 787D, and 788C. Figure 4 illustrates the replaceable load assembly for the 788C, 786D, and 787D load assemblies are not field-replaceable. Figures 5 and 6 illustrate the replaceable 11523A load resistor assembly. Stock numbers required when ordering replacement parts are given in the respective assembly illustrations. To order a replacement part, address order of inquiry to your local Hewlett-Packard sales and service office (see listings at the rear of this Note).

27. DETECTOR ELEMENT REPLACEMENT.

CAUTION

The detector element (see Figure 3) can be damaged electrically by incorrect handling. Read the following handling precautions before doing anything which involves detector element.

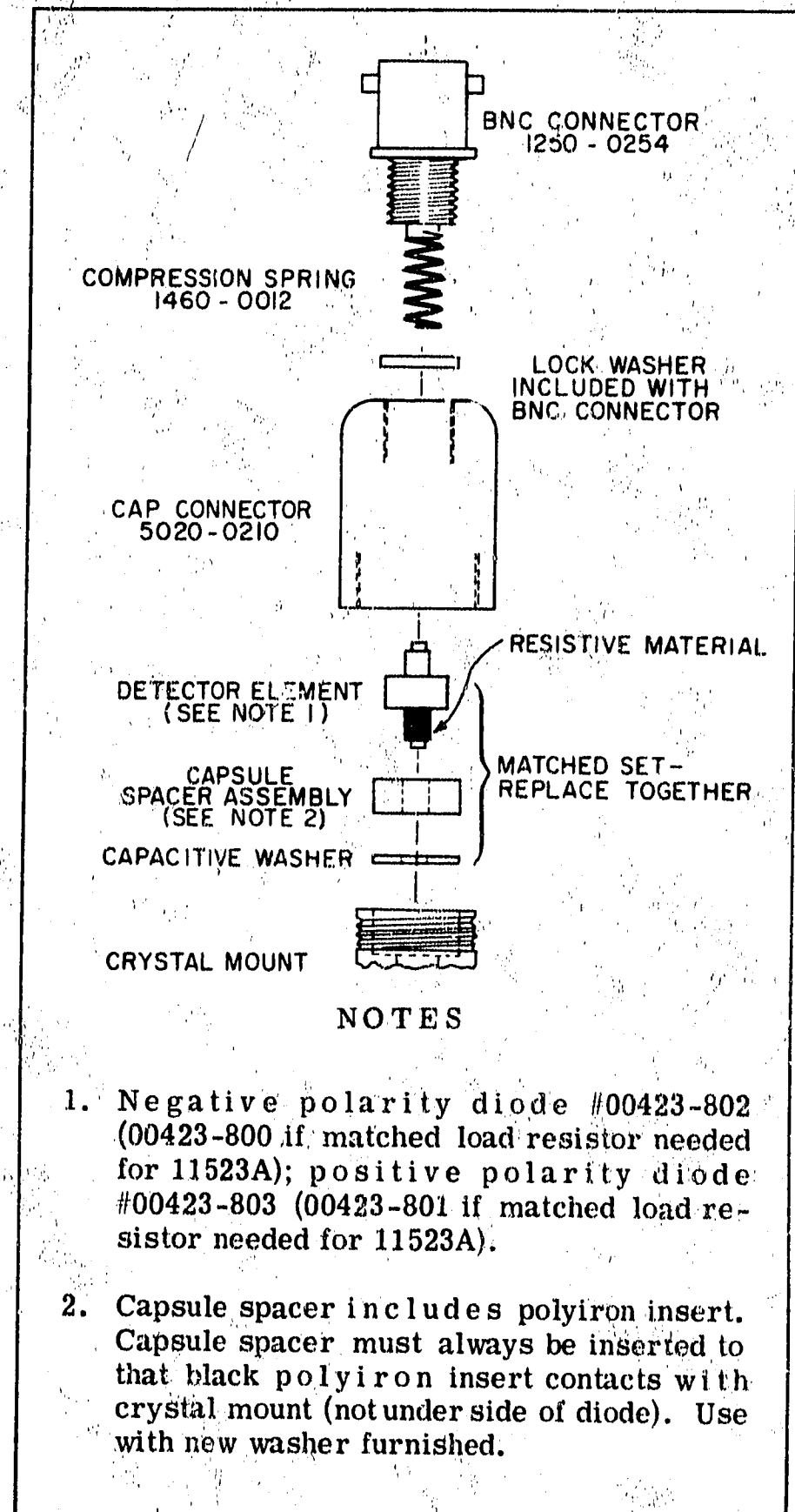

Figure 3. Detector Unit Assembly

28. HANDLING PRECAUTIONS.

- a. Before installing detector element in mount, touch exposed metal on mount with hand to discharge any static charge. Then insert detector element.
- b. When handing crystal to another person, touch hands first to ensure there is no difference in static electrical potential between you.
- c. Do not use an ohmmeter to measure forward- and back-resistance. The open-circuit voltages and short-circuit currents from the ohmmeter can damage detector element (diode).

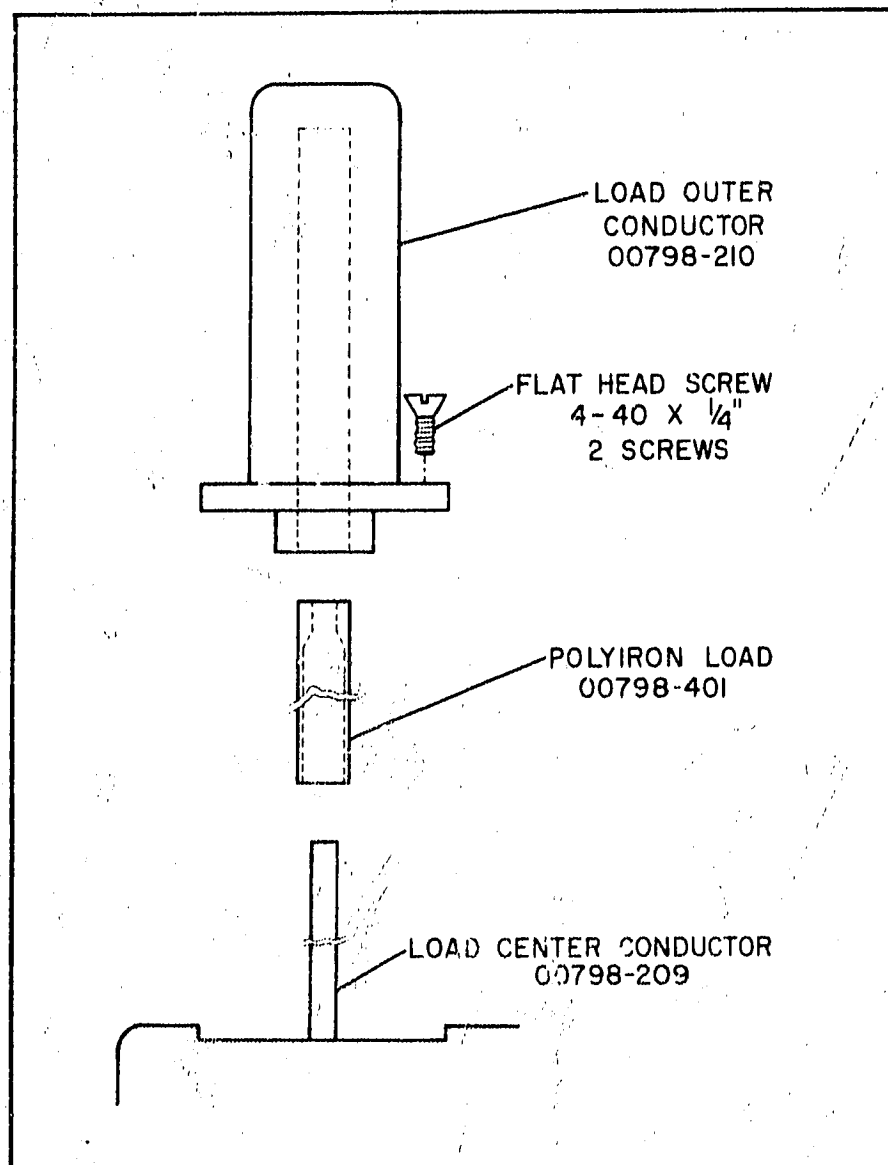

Figure 4. 788C Load Assembly

29. PROCEDURE.

- a. Note Figure 3 and remove connector cap from body. To remove connector cap, use gas pliers with nylon jaws or protect connector body with heavy paper or tape.
- b. Remove old detector element.
- c. Install replacement detector element; black resistive end goes into crystal mount (detector element is a snug fit but not a forced fit).
- d. Replace connector cap and **TIGHTEN FIRMLY.**

Note

A resistor is included with each replacement detector element ordered by the -800 or -801 number given in Figure 3. The resistor is for use in 11523A Load Resistor and must be installed to retain proper square-law operation if the directional detector is equipped with this optional load.

30. DETECTOR BNC REPLACEMENT.

31. TOOLS REQUIRED.

- a. Needle-point soldering iron.
- b. Gas pliers with nylon jaws.
- c. Male BNC mating connector
- d. Tweezers.

32. PROCEDURE.

- a. Refer to Figure 3. Remove BNC connector and lockwasher.
- b. Unsolder spring soldered to center conductor lead.
- c. Slip spring over center conductor lead of new BNC and solder.
- d. Let spring cool and then replace lockwasher and connector in connector cap.

33. 788C LOAD REPLACEMENT.

- a. Refer to Figure 4. Remove two retaining screws and the load outer conductor.
- b. Remove load and any loose or broken portions of the old load from inside the load outer conductor.
- c. Replacement is the reverse of removal.

34. REPLACEMENT OF 11523A MALE BNC.

- a. Refer to Figure 5. Unscrew male BNC and lockwasher from housing by using a 3/8-inch open-end wrench and holding housing either in a vise or with gas pliers.

Note

If gas pliers do not have nylon jaws, the housing should be protected.

- b. Unsolder resistor.
- c. Solder resistor to new BNC.

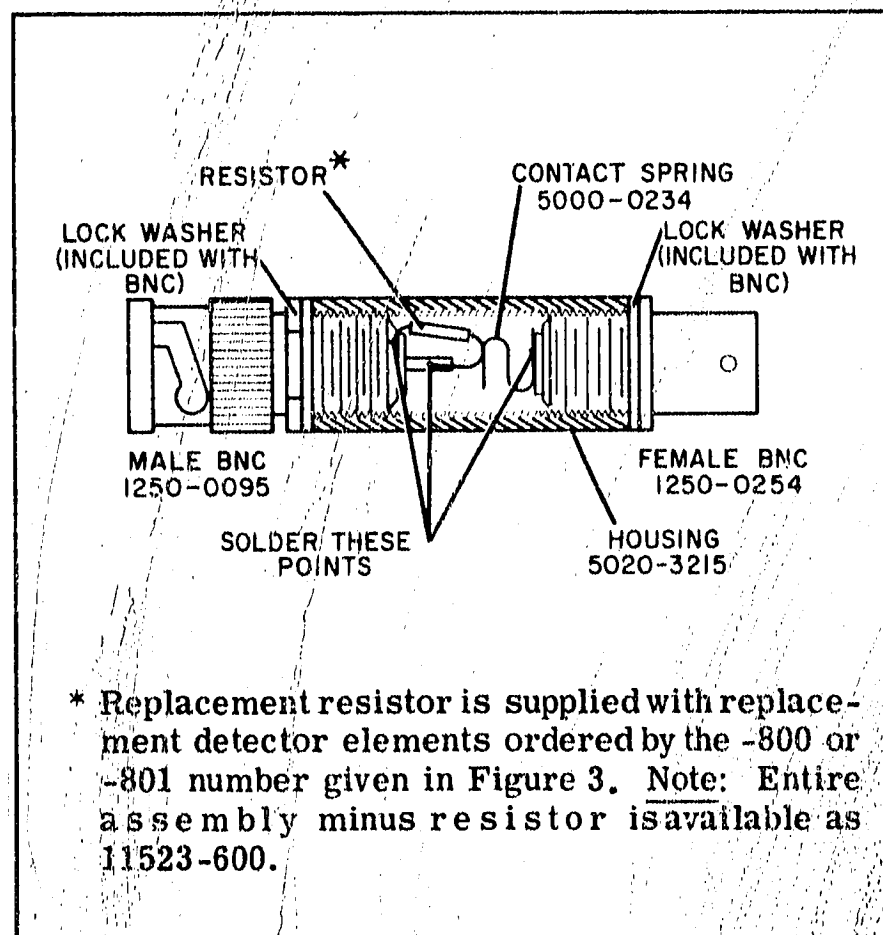

Figure 5. 11523A Cutaway View

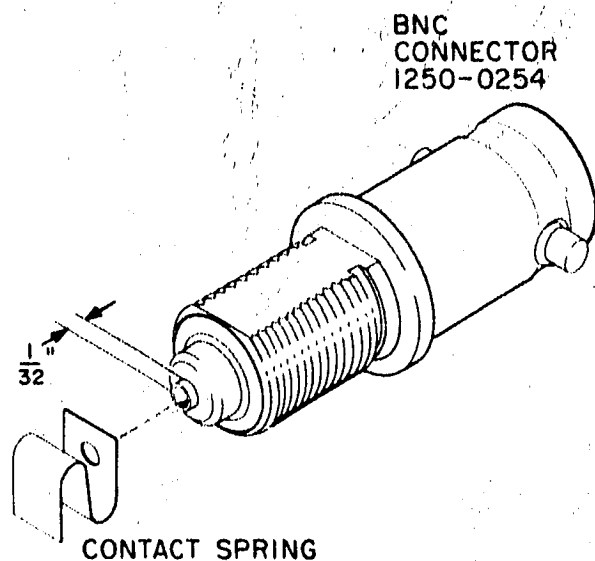

Figure 6. 11523A BNC Assembly

d. Let resistor cool, then check resistance from male BNC pin through resistor; resistance measured should be within 10% of that indicated by the coding.

e. Replace lockwasher and male BNC.

35. REPLACING 11523A FEMALE BNC.

a. Unscrew BNC with a BNC wrench or male BNC used as a wrench.

b. Unsolder contact spring.

c. Prepare replacement BNC connector:

(1) Cut center conductor lead to approximately 1/32 inch (refer to Figure 6).

(2) With flat file, smooth end of lead; wipe off burr with tweezers or similar metal instrument.

d. Slip contact spring over center conductor lead and solder.

CAUTION

Use solder sparingly or it will creep back on spring. Solder on spring destroys its usefulness and is difficult to remove.

e. Let contact spring cool and then screw BNC into housing.

36. PERFORMANCE CHECKS.

37. The performance check procedures given in Paragraphs 39 through 47 verify that the directional detector meets its specifications. Test setups and instructions are given only for the 786D. Measurement techniques for the 787D and 788C are similar and differences in specification are mentioned where they exist.

38. Table 3 lists the recommended test equipment. Other equipment may be used provided it meets or exceeds the critical specifications.

39. FREQUENCY RESPONSE CHECK.

FREQUENCY RESPONSE: ± 0.2 dB
(± 0.3 dB for 788C).

a. Set up test equipment as shown in Figure 7. While the purpose of the low pass filter is to eliminate the effects of harmonics in the sweep oscillator output it is not effective at the lowest frequencies because of its octave pass band. As a result, harmonics can cause out of tolerance indications at these lower frequencies. The attenuator shown at the input to the directional detector should be large enough to hold the power reaching the thermistor mount below the damage level (30 mW average for the Model 478A).

b. Set sweep oscillator for a leveled RF output.

c. Set RF output level for a convenient reference near full scale on power meter.

d. Set sweep oscillator for manual sweeping. Note total variation of power meter indication while manually sweeping frequency slowly through the directional detector range. Total variation should not exceed 0.4 dB (0.6 dB for 788C). If this variation is exceeded, monitor dc output of 786D by means of a BNC tee and SWR Meter. Subtract Δ SWR Meter from Δ Power Meter.

40. SENSITIVITY CHECK.

SENSITIVITY: > 100 mV detected output for 35 mW (3.5 mW for 788C) RF output.

a. Set up test equipment as shown in Figure 7 with the following exceptions: the 10-dB Pad should be connected between 786D and 478A and detected output connected to a dc voltmeter through a BNC-to-binding post adapter.

CAUTION

Average RF power exceeding 30 mW will damage the HP 478A Thermistor Mount. Do not apply more than 30 mW to mount.

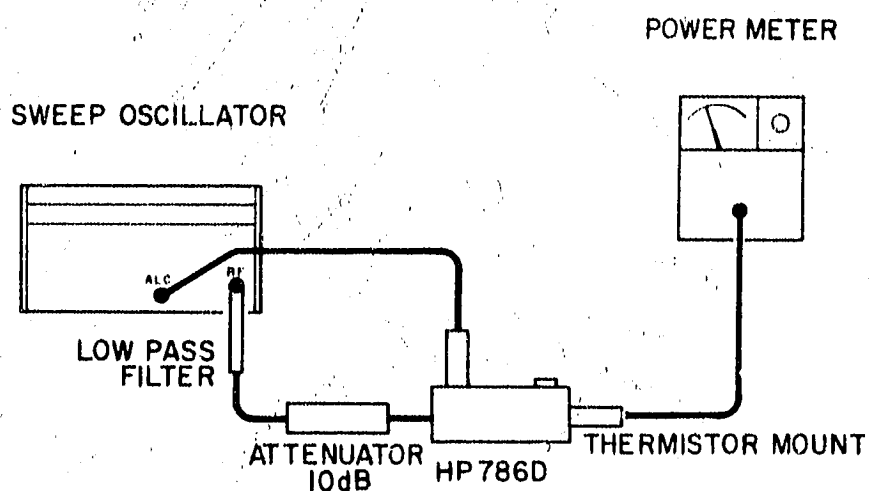

Figure 7. Frequency Response Check

Table 3. Recommended Test Equipment

Instrument Type	Critical Specifications	Check	Model
Sweep Oscillator	Frequency Range: (directional detector) Power Output: 10 mW Leveled Capability:* ± 0.1 dB Residual FM: Less than 50 kHz	All	H21-8691A/B (786D) 8692A/B (787D) 8693A/B (788C)
Low-Pass or Bandpass Filter	Frequency Range: (directional detector) Rejection: Not less than 40 dB	All	360B (786D) 360C (787D and 786D) 360D (787D and 788C) Microphase LTP 8200 + 360D (788C)
Power Meter and Thermistor Mount	Frequency Range: (directional detector) Power Range: -10 to +10 dBm Accuracy: $\pm 3\%$	Frequency Response Sensitivity	431C (meter) and 478A (mount)
Fixed Attenuator	Frequency Range: (directional detector) Attenuation: 10 dB	Frequency Response Sensitivity SWR	8491A-10
	Frequency Range: (directional detector) Attenuation: (directional detector directivity)	Directivity	8491-010 (786D) 8491-020 (all) 8491-006 (787D)
DC Voltmeter	Range: 20 to 100 mV Input: 10 megohms Accuracy: $\pm 2\%$ of full scale	Sensitivity	412A
SWR Meter	Frequency: 1000 Hz $\pm 2\%$ Calibration: Square Law Accuracy: ± 0.05 dB (on EXPAND scale) Input: 200K ohms	SWR Directivity	415B or 415E
Directional Detector	Frequency Range: (directional detector) Detected Output: Negative Sensitivity: $4 \mu\text{V}/\mu\text{W}$ Frequency Response: ± 0.3 dB	Directivity	786D (786D) 787D (787D) 788C (788C)
Sliding Load	Frequency Range: (directional detector) Connectors: Standard type N Residual SWR:** 1.05	SWR Directivity	905A/907A
Slotted Line	Frequency Range: (directional detector) Connectors: Standard type N Residual SWR: 1.04	SWR	805C (786D and 787D) 817A Swept Slotted Line System
<p>* Excluding coupler and detector variation (with the 786D the leveling capability would be ± 0.3 dB).</p> <p>** Residual SWR: 1.10 from 1.0 to 1.5 GHz.</p>			

b. Starting at minimum, carefully increase CW-RF power to obtain a 100-mV reading on the dc voltmeter. Specification: 35 mW (3.5 mW for 788C) or less (power meter reading plus attenuation of attenuator) produces a 100-mV detected output.

c. Repeat above check at all points of interest across the band.

41. SWR CHECK (Swept Frequency).

MAIN LINE SWR: ≤ 1.15 (1.20 for 788C).

42. Swept-frequency SWR testing is preferred since it will show narrow out-of-specification frequency bands which might be missed with fixed-frequency testing. To sweep test proceed as follows:

a. Connect equipment as shown in Figure 8 Equipment Setup.

b. Level the sweep oscillator as instructed in Figure 9.

c. Correct the detector at the point marked "Device under test" in Figure 8.

d. Set the sweep oscillator to sweep the band of interest.

e. With the oscilloscope on LOGARITHMIC MODE, move the carriage over at least one-half wavelength (if a storage oscilloscope is not available take a time exposure of the trace).

f. Measure the width of the trace at the widest part. Reverse the detector and repeat measurement.

g. Run a trace with the carriage stationary. Read the trace width. Subtract this reading from the reading obtained in step e.

h. Compute the voltage ratio using the formula:

$$\text{SWR} = \log^{-1} (\text{dB}/20)$$

or

$$1.15 \text{ SWR} = 1.2 \text{ dB}$$

and

$$1.20 \text{ SWR} = 1.56 \text{ dB}$$

43. If the bandwidth of the oscilloscope is too low or the sweep rate too high, some of the fine structure of the SWR pattern will be lost. Due to noise the widest bandwidth may not give the best pattern, but the optimum combination can easily be determined experimentally by keeping the slotted-line carriage stationary

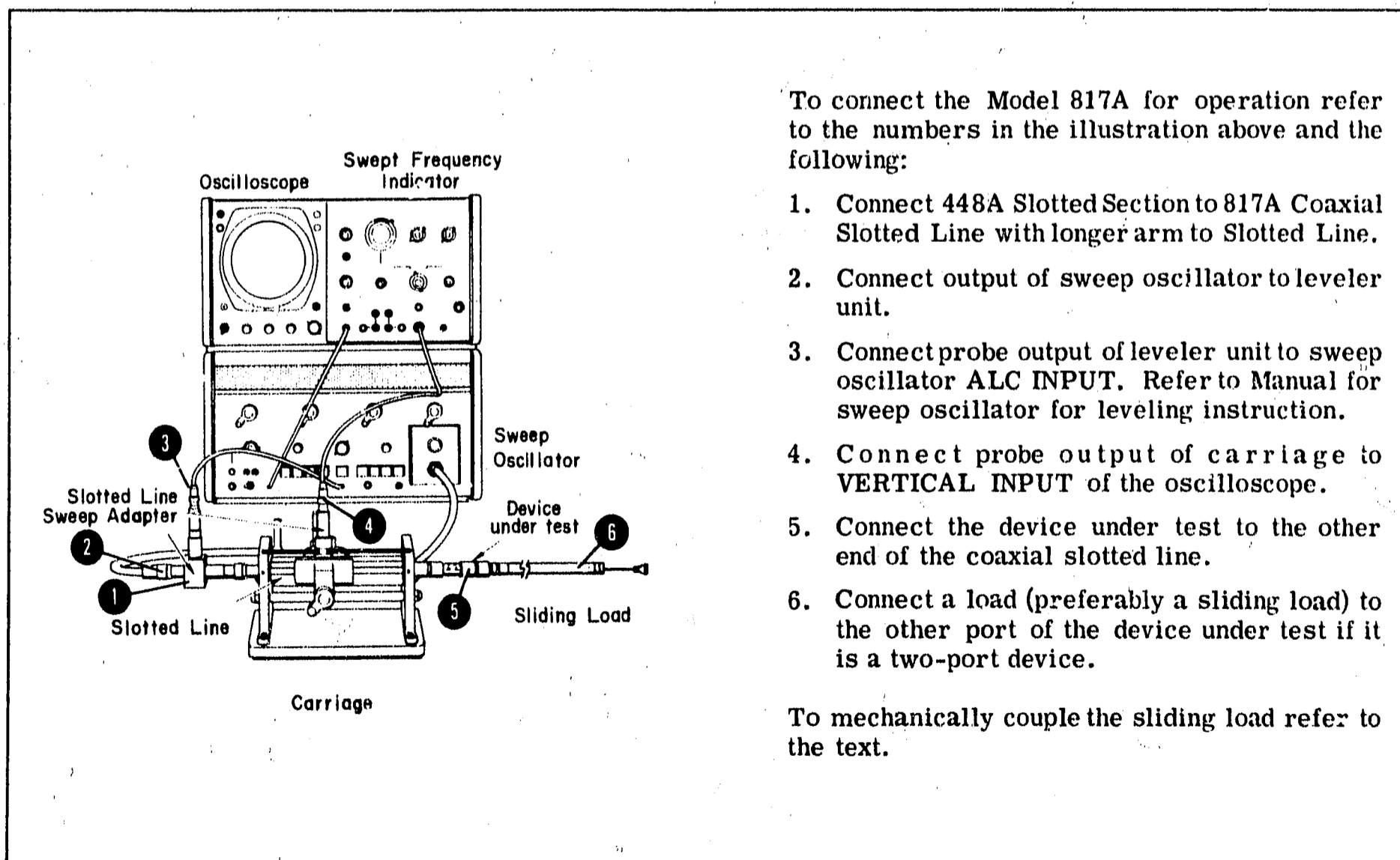

To connect the Model 817A for operation refer to the numbers in the illustration above and the following:

1. Connect 448A Slotted Section to 817A Coaxial Slotted Line with longer arm to Slotted Line.
2. Connect output of sweep oscillator to leveler unit.
3. Connect probe output of leveler unit to sweep oscillator ALC INPUT. Refer to Manual for sweep oscillator for leveling instruction.
4. Connect probe output of carriage to VERTICAL INPUT of the oscilloscope.
5. Connect the device under test to the other end of the coaxial slotted line.
6. Connect a load (preferably a sliding load) to the other port of the device under test if it is a two-port device.

To mechanically couple the sliding load refer to the text.

Figure 8. Equipment Setup

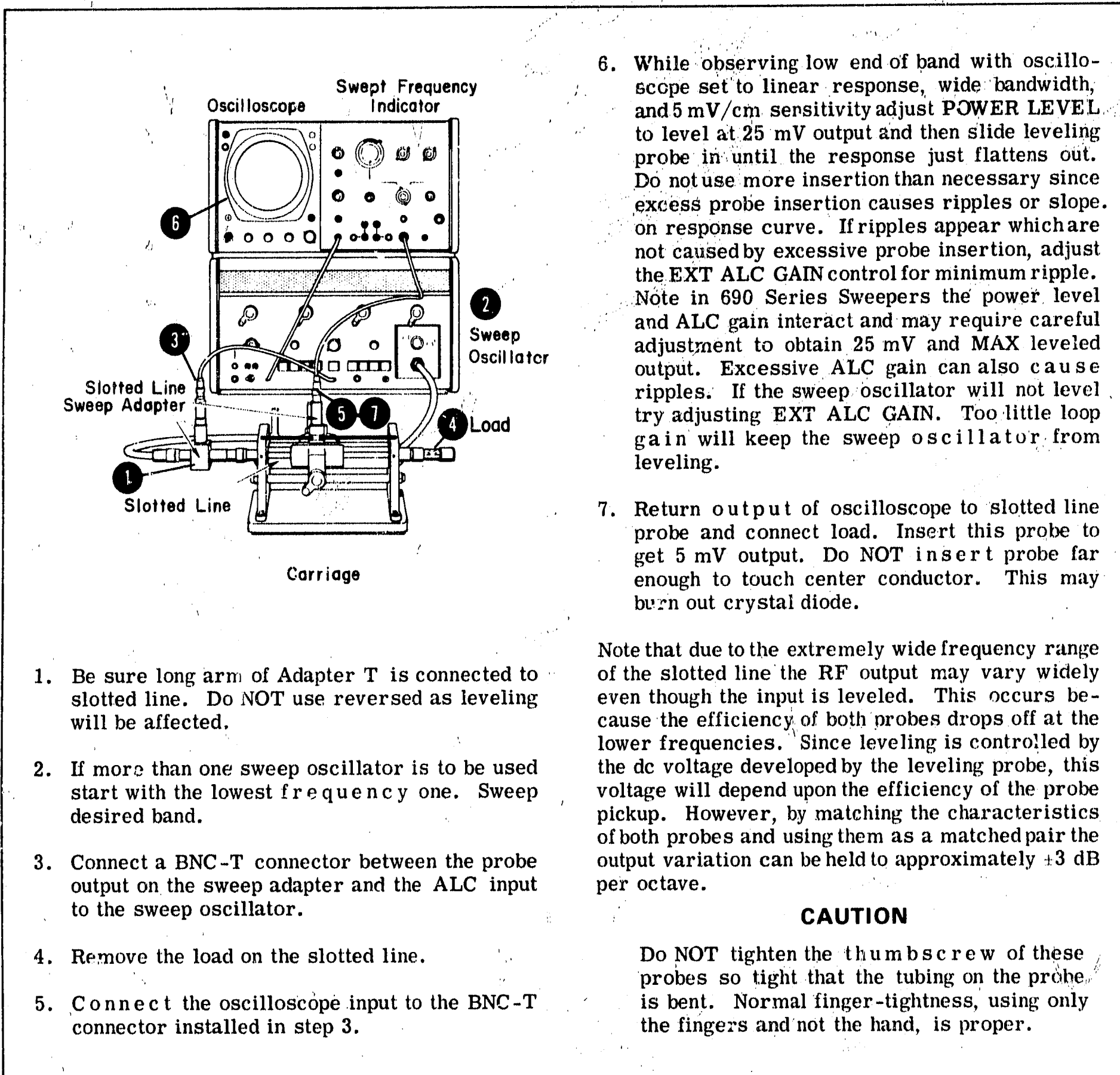

Figure 9. Leveling

and adjusting the sweep rate and bandwidth for the most crooked trace (for further information see Stephen F. Adam, "Swept-Frequency SWR Measurements in Coaxial Systems" *HP Journal*, Vol. 18, No. 4, Dec. 1966, pp 15-20; or Application Note 84, both obtainable free from your nearest HP office.

44. A more exact method of measuring SWR is to couple the sliding load to the probe mechanically so that they both move together (see Figure 10). This eliminates the effect of reflection due to the load since the load is in the same phase relationship to the

probe at all times.¹ To couple a slotted line carriage mechanically use a piece of 3/8" round aluminum tubing approximately 18" long plus the length of the directional detector with a right-angle bend 4" from one end. Clamp a 7/8" ID cable clamp around the

¹ B. O. Weinschel, et al., "Precision Coaxial VSWR Measurement by Coupled Sliding-Load Technique," *IEEE Transactions on Instrumentation and Measurements*, Vol. IM-13, No. 4, Dec. 1964, pp 292-300.

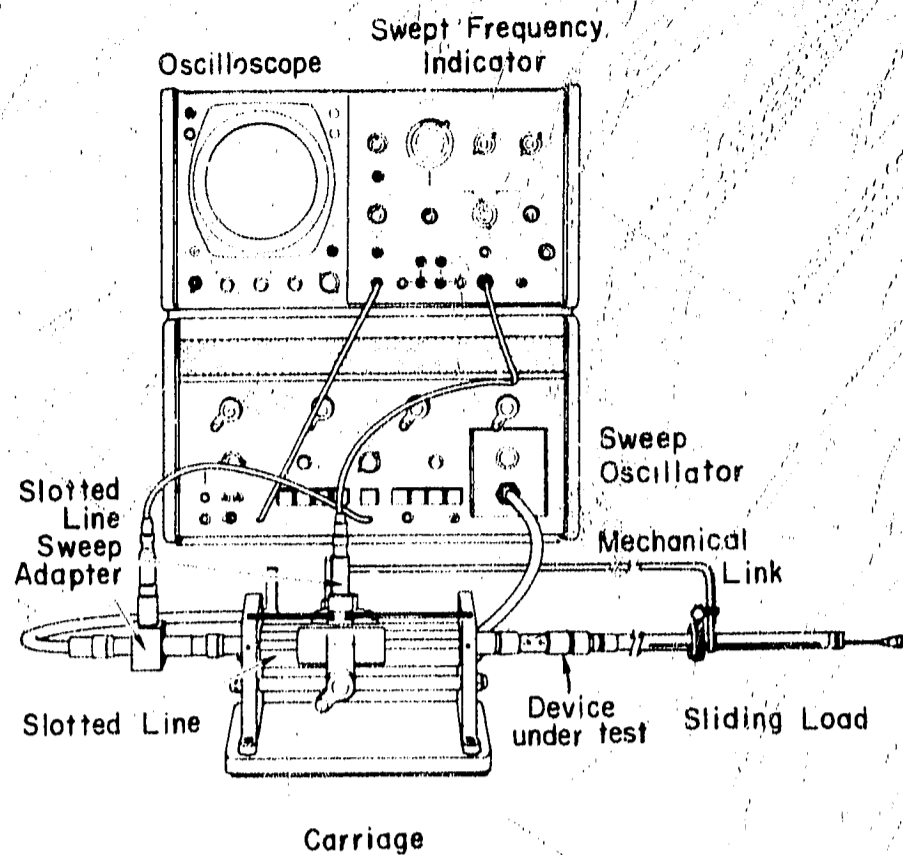

Figure 10. Mechanically-Coupled Sliding Load

adjusting barrel of the load and connect the two cable clamps together. Connect the long end of the shaft to the moving portion of the slotted line carriage. If an HP Model 809B/C Slotted Line Carriage is used, the shaft can be clamped in the micrometer holder. Adjust the various clamps so that the load tracks with the carriage over the entire length of travel. This technique can also be used with single-frequency measurements eliminating the need for computations.

45. If the results are doubtful at any frequency, test for SWR at that frequency using the single-frequency SWR test which follows.

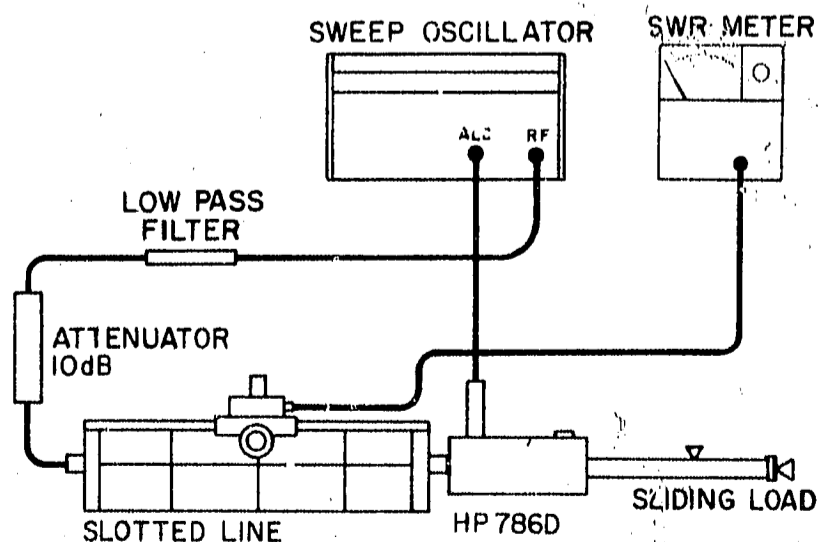

Figure 11. SWR Check

46. SWR CHECK (Single Frequency).

MAIN LINE SWR: ≤ 1.15 (1.20 for 788C).

- Set up test equipment as shown in Figure 11.
- Set sweep oscillator for a single frequency, 1000-Hz square-wave modulated RF output.
- Adjust square-wave modulation frequency for maximum SWR Meter indication on 40-dB NORMAL scale.
- Phase sliding load to obtain minimum SWR scale indication.
- Adjust slotted line carriage for minimum SWR-scale indication as near center of slotted section as possible. Repeat steps d and e for absolute minimum reading since the steps interact.
- Set a 1.0 indication on SWR Meter SWR-EXPAND scale.
- Adjust slotted line for a maximum SWR-scale indication.
- Phase sliding load for a minimum SWR reading and record. Specification: SWR reading must not exceed 1.15 (1.20 for 788C).

47. DIRECTIVITY CHECK.

MINIMUM DIRECTIVITY: 30 dB for 786D
(26 dB for 787D; 20 dB for 788C).

- Set up equipment as shown in Figure 12.

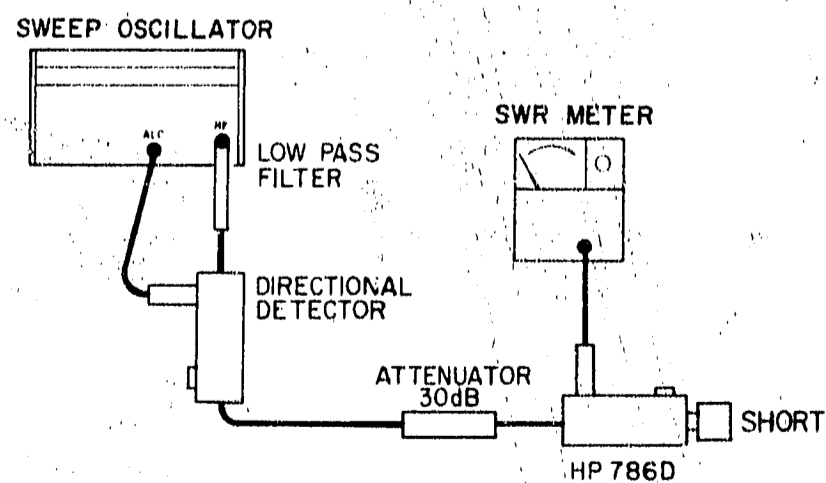

Figure 12. Directivity Check

- b. Set sweep oscillator for leveled, square-wave modulated RF output.
- c. Set 0-dB reference on SWR Meter.
- d. Remove Attenuator from setup.
- e. Connect short to male connector (786D under test) and using a female-to-female adapter connect 786D under test to 786D.
- f. Set sweep oscillator for 100-second sweep rate.
- g. Note SWR Meter indication and continuously phase sliding load. If both minimum and maximum indications are greater than the 0-dB reference, the directional detector meets the directivity specifications. However, these readings are uncorrected, worse-than-actual-value readings.
- h. To determine actual directivity first add attenuation of attenuators used in step a to each reading made in step g; then subtract minimum from maximum readings and find difference value (M_1). For example,

if readings were 0.5 and 5.4 dB and assuming attenuation of attenuators used is equal to 30 dB, then the minimum is 30.5 dB and the maximum is 35.4 dB. The difference between the two readings is 4.9 dB (which is M_1).

- i. Refer to Figure 13. Determine values for M_2 which are the two correction factors to be used. Add the minimum reading of step h to each correction (M_2). For example, if the difference in dB (M_1) is 4.9 dB, then from the graph (Figure 13) the two corrections are 2.1 and 13.3 dB. One corrected value is sliding load return loss and the other is 786D directivity, but it is impossible to distinguish which.

- j. To identify directivity reading, loosen sliding load center conductor lock and slightly loosen connection to 786D without rotating center conductor. Tighten lock.

- k. Repeat steps d through i. The corrected value for sliding load return loss should remain practically the same as original corrected reading (within a few tenths of a dB). The 786D directivity is the other original corrected reading, which has changed.

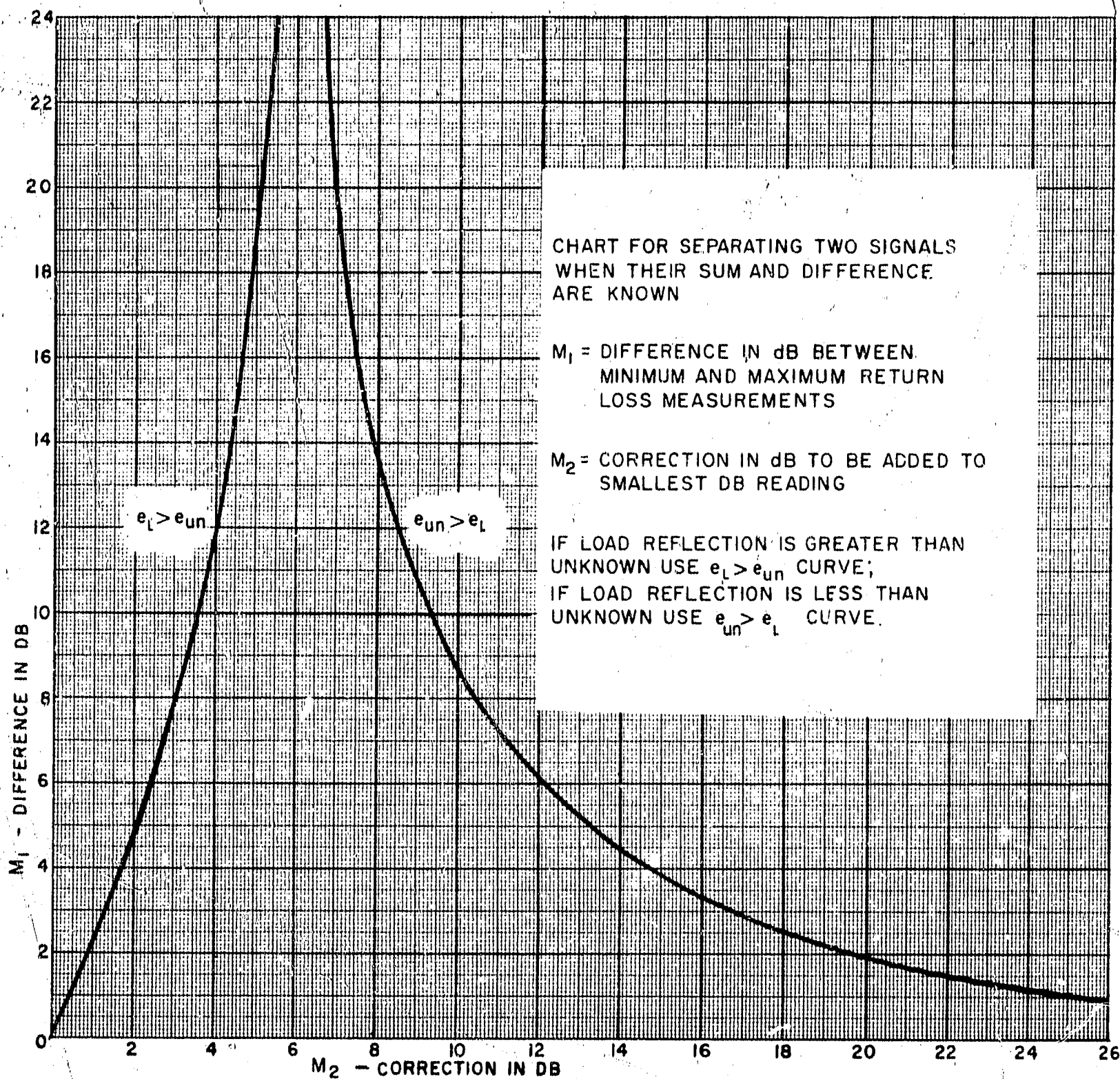

Figure 13. Signal Separation Chart

m. The following is an example of measurement steps with actual readings and conclusions.

- (1) SWR Meter readings were 0.5 and 5.4 dB.
- (2) The attenuators used were 20 dB and 10 dB; hence, the readings indicate 30.5 and 35.4 dB.
- (3) The difference between the minimum and maximum readings is then 4.9 dB.
- (4) Referring to Figure 13, the two correction factors are 2.1 and 13.3 dB.
- (5) The minimum reading (30.5 dB) added to each results in two corrected readings: 32.6 and 43.8 dB.
- (6) To determine which reading represents the sliding load, the sliding load center conductor is partially unplugged from the 786D.
- (7) The above steps were repeated which resulted in SWR Meter indications of 25.5 and 28.0 dB. The difference between the two readings is

2.5 dB which from Figure 13 determined the two correction factors to be 1.2 and 18.0 dB.

- (8) The two correction factors added to the 25.5 dB minimum gave corrected readings of 26.7 and 43.5 dB.
- (9) The sliding load return loss was 43.5 to 43.8 dB, because making a bad connection between the sliding load and the 786D did not affect this reading much.
- (10) The 786D directivity was 32.6 dB, because making a bad connection between the sliding load and the 786D did affect this reading causing a reading which did not agree with either of the previous corrected readings.

48. PARTS REPLACEMENT.

49. Parts replacement for these directional detectors by the customer is not recommended. The fastest assembly and test time for the most experienced personnel is five full man days per detector.