

## Errata

**Title & Document Type:** 5381A Frequency Counter Operating and Service Manual

**Manual Part Number:** 05381-90010

**Revision Date:** October 1976

### About this Manual

We've added this manual to the Agilent website in an effort to help you support your product. This manual provides the best information we could find. It may be incomplete or contain dated information, and the scan quality may not be ideal. If we find a better copy in the future, we will add it to the Agilent website.

### HP References in this Manual

This manual may contain references to HP or Hewlett-Packard. Please note that Hewlett-Packard's former test and measurement, life sciences, and chemical analysis businesses are now part of Agilent Technologies. The HP XXXX referred to in this document is now the Agilent XXXX. For example, model number HP8648A is now model number Agilent 8648A. We have made no changes to this manual copy.

### Support for Your Product

Agilent no longer sells or supports this product. You will find any other available product information on the Agilent Test & Measurement website:

[www.agilent.com](http://www.agilent.com)

Search for the model number of this product, and the resulting product page will guide you to any available information. Our service centers may be able to perform calibration if no repair parts are needed, but no other support from Agilent is available.



**Agilent Technologies**

OPERATING AND SERVICE MANUAL

# FREQUENCY COUNTER 5381A

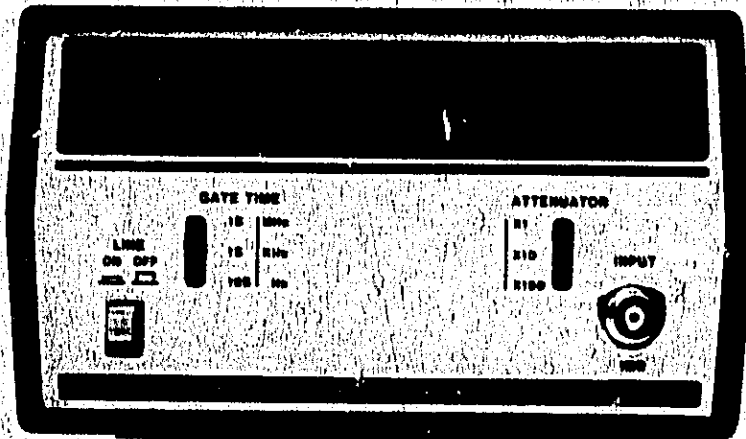

HEWLETT  PACKARD

## **CERTIFICATION**

*Hewlett-Packard Company certifies that this instrument met its published specifications at the time of shipment from the factory. Hewlett-Packard Company further certifies that its calibration measurements are traceable to the United States National Bureau of Standards, to the extent allowed by the Bureau's calibration facility, and to the calibration facilities of other International Standards Organization members.*

## **WARRANTY AND ASSISTANCE**

This Hewlett-Packard product is warranted against defects in materials and workmanship for a period of one year from the date of shipment. Hewlett-Packard will, at its option, repair or replace products which prove to be defective during the warranty period provided they are returned to Hewlett-Packard, and provided the preventive maintenance procedures in this manual are followed. Repairs necessitated by misuse of the product are not covered by this warranty. **NO OTHER WARRANTIES ARE EXPRESSED OR IMPLIED, INCLUDING, BUT NOT LIMITED TO, THE IMPLIED WARRANTIES OF MERCHANTABILITY AND FITNESS FOR A PARTICULAR PURPOSE. HEWLETT-PACKARD IS NOT LIABLE FOR CONSEQUENTIAL DAMAGES.**

Service contracts or customer assistance agreements are available for Hewlett-Packard products.

For any assistance, contact your nearest Hewlett-Packard Sales and Service Office. Addresses are provided at the back of this manual.

# OPERATING AND SERVICE MANUAL

## FREQUENCY COUNTER

### 5381A

#### SERIAL NUMBERS: 1624A

This manual applies directly to HP Model 5381A Frequency Counters having serial numbers prefixed 1624A. With changes described in Section IV, this manual also applies to instruments with serial numbers prefixed 1548A, 1532A, 1520A, and 1404A.

For additional information about serial numbers, see INSTRUMENT IDENTIFICATION in Section I.

#### NEWER INSTRUMENTS

This manual, with enclosed "Manual Changes" sheet, applies to HP Model 5381A Frequency Counters having serial number prefixes as listed on the "Manual Changes" sheet.

Copyright © HEWLETT-PACKARD COMPANY 1973  
5301 STEVENS CREEK BLVD., SANTA CLARA, CALIF. 95050

Printed: OCT 1976

MANUAL PART NUMBER 05381-90010  
MICROFICHE PART NUMBER 05381-90011

PRINTED IN U.S.A.

HEWLETT  PACKARD

## TABLE OF CONTENTS

Section	Title	Page
I	GENERAL INFORMATION .....	1-1
	1-1. Introduction .....	1-1
	1-3. Instrument Description .....	1-1
	1-5. Instrument Identification .....	1-1
	1-8. Specifications .....	1-2
II	INSTALLATION AND OPERATION .....	2-1
	2-1. Introduction .....	2-1
	2-3. Unpacking and Inspection .....	2-1
	2-5. Storage and Shipment .....	2-1
	2-8. Line Voltage Selection .....	2-1
	2-11. Operation .....	2-2
	2-13. Cable and Termination Requirements .....	2-2
	2-15. Ratio Measurements .....	2-3
	2-17. Optimizing Noise Rejection .....	2-3
III	MAINTENANCE .....	3-1
	3-1. Introduction .....	3-1
	3-3. Theory of Circuit Operation .....	3-1
	3-5. Input Circuits .....	3-2
	3-7. Decade Counter, Latch, and Multiplexer Circuits .....	3-2
	3-9. Time Base Oscillator and Divider .....	3-2
	3-11. Display Scanner .....	3-2
	3-14. Reset and Transfer Control Circuits .....	3-3
	3-16. Recommended Test Equipment .....	3-3
	3-18. In-Cabinet Performance Check .....	3-3
	3-20. Instrument Access .....	3-5
	3-22. Preventive Maintenance .....	3-6
	3-24. General Repair .....	3-6
	3-23. Adjustments .....	3-6
	3-30. Amplifier Balance Adjustment .....	3-6
	3-32. Oscillator Adjustment, Standard and Option 001 .....	3-9
	3-33b. Option 001 TCXO Oscillator Adjustment .....	3-9
	3-34. Troubleshooting .....	3-9
	3-37. Replaceable Parts .....	3-10
	3-39. Replacement LED Digital Display Units .....	3-10
	3-41. Ordering Information .....	3-11
	3-43. Schematic Diagram .....	3-11
IV	MANUAL CHANGES .....	4-1
	4-1. Introduction .....	4-1
	4-3. Manual Changes .....	4-1
	4-5. Newer Instruments .....	4-1
	4-6. Older Instruments .....	4-1

## LIST OF TABLES

Table	Title	Page
1-1.	Specifications .....	1-2
3-1.	Recommended Test Equipment .....	3-3
3-2.	In-Cabinet Performance Check .....	3-4
3-3.	Replaceable Parts, Standard Instrument .....	3-13
3-4.	Manufacturers Code List .....	3-16
3-5.	A1 Replaceable Parts, Option 001 .....	3-17

**LIST OF TABLES (Continued)**

Table	Title	Page
4-1.	Manual Backdating .....	4-1
4-2.	Replaceable Parts, A1 Series 1404 .....	4-4
4-3.	Replaceable Parts, A1 Series 1548 .....	4-5

**LIST OF FIGURES**

Figure	Title	Page
1-1.	Model 5381A Frequency Counter .....	1-1
2-1.	Line Voltage Selector Settings .....	2-1
2-2.	Power Cord Connector for 240-Volt Operation .....	2-2
2-3.	Front Panel Operating Controls, Connectors, and Indicators .....	2-3
2-4.	Rear Panel Operating Controls and Connectors .....	2-4
3-1.	Simplified Block Diagram .....	3-1
3-2.	Troubleshooting Flow Chart .....	3-7
3-3.	Schematic Diagram Notes .....	3-19
3-4.	Instrument Timing Diagram .....	3-20
3-5.	A1 (05381-60006) Series 1624 Component Locator .....	3-21
3-6.	A2 Component Locator .....	3-22
3-7.	Overall Schematic Diagram .....	3-23
4-1.	A1 Main Board, Schematic Diagram/Component Locator, Series 1404 .....	4-9
4-2.	A1 Main Board, Schematic Diagram/Component Locator, Series 1548 .....	4-9

## SAFETY CONSIDERATIONS

### GENERAL

This is a Safety Class I instrument. This instrument has been designed and tested according to IEC Publication 348, "Safety Requirements for Electronic Measuring Apparatus".

### OPERATION

**BEFORE APPLYING POWER** verify that the power transformer primary is matched to the available line voltage and the correct fuse is installed (see Section II, Paragraph 2-9). Make sure that only fuses with the required rated current and of the specified type (normal blow, time delay, etc.) are used for replacement. The use of repaired fuses and the short-circuiting of fuseholders must be avoided.

### SERVICE

Although this instrument has been designed in accordance with international safety standards, this manual contains information, cautions, and warnings which must be followed to ensure safe operation and to retain the instrument in safe condition. Service and adjustments should be performed only by qualified service personnel.

Any adjustment, maintenance, and repair of the opened instrument under voltage should be avoided as much as possible and, when inevitable, should be carried out only by a skilled person who is aware of the hazard involved.

Capacitors inside the instrument may still be charged even if the instrument has been disconnected from its source of supply.

Whenever it is likely that the protection has been impaired, the instrument must be made inoperative and be secured against any unintended operation.

### ATTENTION

This symbol: , which appears on 5381A instrument rear panel means: Read the instruction manual before operating the instrument. The first two sections of the manual are particularly important. If the instrument is operated without reading the instructions, the counter may not operate correctly.

### WARNING

**100-240 VOLTS AC ARE USED IN THIS INSTRUMENT. MAINTENANCE AND SERVICING SHOULD BE PERFORMED BY QUALIFIED SERVICE PERSONNEL ONLY. LINE VOLTAGE IS ALWAYS PRESENT ON SOME TERMINALS INCLUDING THE POWER INPUT CONNECTOR, FUSE HOLDER, POWER SWITCH, AND OTHER POINTS. ENERGY AVAILABLE AT MANY POINTS MAY RESULT IN PERSONAL INJURY OR DEATH WHEN CONTACTED.**

### CAUTION

This instrument is equipped with 100V-120V-220V-240V selector switches. Before connecting the instrument to AC power lines, be sure the line selector switches are set properly per paragraph 2-8.

## SECTION I GENERAL INFORMATION

### 1-1. INTRODUCTION

1-2. This section of the manual gives a description of the instrument, instrument identification information, and complete specifications.

### 1-3. INSTRUMENT DESCRIPTION

1-4. The HP Model 5381A Frequency Counter (see Figure 1-1) is a direct-counting frequency counter that has a range of 10 Hz to 80 MHz. Seven display digits are provided. Front-panel controls allow a selection of gate times and attenuation factors of the input signal. A rear-panel connector and associated selector switch allow connection of an external time base oscillator. This feature also allows ratio measurements to be made by the counter. Refer to Table 1-1 for all counter specifications.

### 1-5. INSTRUMENT IDENTIFICATION

1-6. Hewlett-Packard uses a two-section, nine-digit serial number (0000A00000) mounted on the rear panel to identify the instrument. The first four digits are the serial prefix and the last five digits refer to the specific instrument. If the serial prefix on your instrument differs from that listed on the title page of this manual, there are differences between the manual and your instrument. Any lower serial prefixes are documented in Section IV of this manual and higher serial prefixes are covered by a manual change sheet included with the manual.

### 1-7. SPECIFICATIONS

1-8. Table 1-1 lists all specifications of the frequency counter.

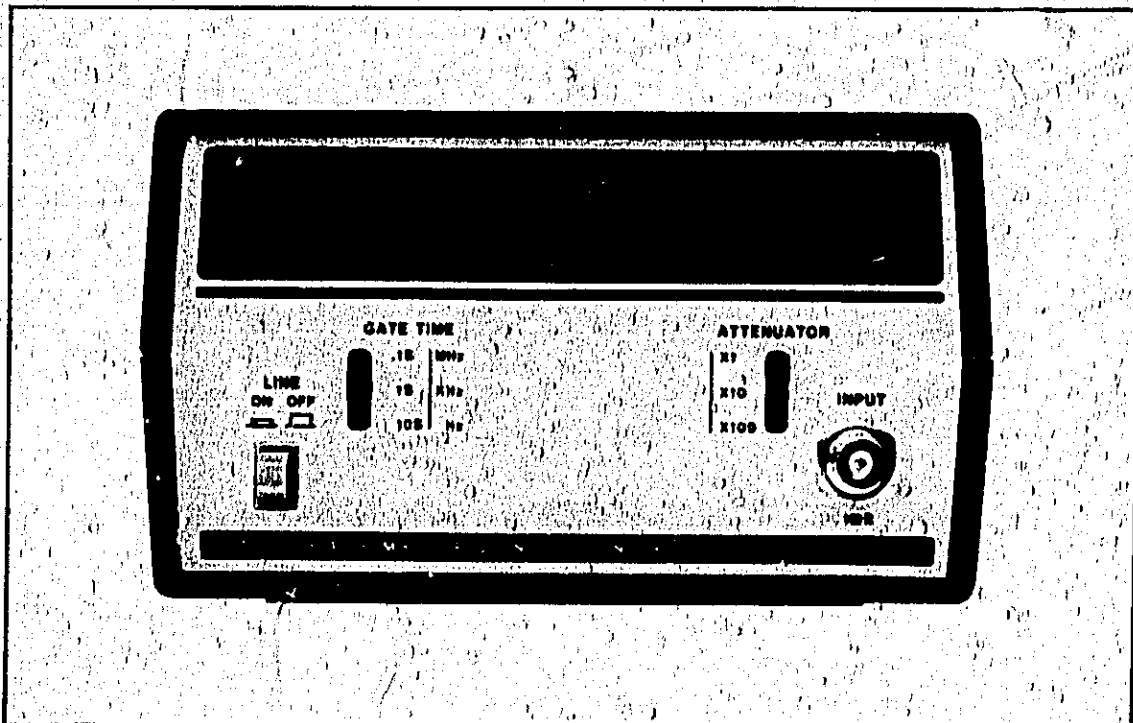

Figure 1-1. Model 5381A Frequency Counter

**Model 5381A  
General Information**

**Table 1-1. Specifications**

**Frequency Range:** 10 Hz to 80 MHz

**Display:** 7 Digit (LED's)

**Input Impedance:** 1 MΩ, 50 pF

**Sensitivity:** 25 mV (rms Sinewave) 30 Hz to 20 MHz  
50 mV (rms Sinewave) 10 Hz to 80 MHz

**Input Attenuator:** Three Position (x1, x10, x100)

**Maximum Input Level:**

Attenuator "x1"	DC to 40 Hz	200 V (dc + Peak ac)
	40 Hz to 100 kHz	250 V rms
	100 kHz to 5 MHz	2.5 x 10 <sup>7</sup> V Hz
	>5 MHz	5 V rms

Attenuator "x10" "x100"	DC to 40 Hz	200 V (dc + Peak ac)
	40 Hz to 1 MHz	250 V rms
	1 MHz to 50 MHz	2.5 x 10 <sup>6</sup> V Hz
	50 MHz to 80 MHz	5 V rms

**Accuracy:** ±1 Count ± Time Base Accuracy

**Gate Times:** Manually Selected, 1 second, 1 second, 10 seconds

**Resolution:** 10 Hz at 0.1 second gate time  
1 Hz at 1 second gate time  
0.1 Hz at 10 second gate time

**Time Base:**

**Internal**

**Frequency:** 1 MHz Crystal

**Aging:** <0.3 ppm/Month

**Temperature:** ±10 ppm 0°C to 40°C

**Line Voltage:** ±1 ppm for 10% line variation

**External Input**

**Frequency, Range:** 10 kHz to 2 MHz

**Sensitivity:** TTL Level or 2.5 V rms Sinewave

**Maximum Input:** 25 V rms dc to 2 MHz

**Accessories Available:**

10851A Rack Mounting Kit for mounting one HP Model 5381A, 5382A, 5383A or similar instrument in the center of a standard 48.26 cm (19.00 inches) by 8.89 cm (3.5 inches) panel.

10852A Rack Mounting Kit for side by side mounting of two HP Model 5381A, 5382A, 5383A or similar instruments. Standard panel size 48.26 cm (19.00 inches) long by 8.89 cm (3.5 inches) high.

**Operating Temperature:** 0°C to 40°C

**Power Requirements:** 100, 120, 220, 240V rms (48 Hz to 440 Hz) (+5%-10%) 30 VA max.

**Weight:** Net: 4.75 lb (2.2 kg) Shipping: 6 lb (2.8 kg)

**Dimensions:** 89 mm H, x 160 mm W x 248 mm D (3.5 in. x 6.25 in. x 9.75 in.)

**OPTION 001 TCXO**

**Frequency:** 10 MHz (Temperature Compensated Crystal Oscillator)

**Aging:** <0.1 ppm per month

**Temperature:** <±1 ppm between 0°C and 40°C

**Line Voltage:** <±0.1 ppm for ±10% line (power) variation

**INSTALLATION**

**OPERATION**

## SECTION II INSTALLATION AND OPERATION

### 2-1. INTRODUCTION

2-2. This section of the manual provides information about unpacking, inspecting, storing, and shipping the frequency counter and gives instructions for operating the counter. Descriptions of all controls, connectors, and indicators are included.

### 2-3. UNPACKING AND INSPECTION

2-4. If the shipping carton is damaged, ask that the carrier's agent be present when the instrument is unpacked. Inspect the instrument for damage such as scratches, dents, broken switches, etc. If the instrument is damaged or fails to meet performance tests, notify the carrier and the nearest Hewlett-Packard Sales and Service Office immediately. Performance check procedures are located in Section III, and Sales and Service Offices are listed at the back of this manual. Retain the shipping carton and the padding material for the carrier's inspection. The Sales and Service Office will arrange for the repair or replacement of the instrument without waiting for the claim against the carrier to be settled.

### 2-5. STORAGE AND SHIPMENT

2-6. **PACKAGING.** To protect valuable electronic equipment during storage or shipment, always use the best packaging methods available. Your Hewlett-Packard Sales and Service Office can provide packaging material such as that used for original factory packaging. Contract packaging companies in many cities can provide dependable custom packaging on short notice.

2-7. **ENVIRONMENT.** Conditions during storage and shipment should normally be limited as follows:

- a. Maximum altitude: 25,000 ft.
- b. Minimum temperature:  $-40^{\circ}\text{F}$  ( $-40^{\circ}\text{C}$ ).
- c. Maximum temperature:  $+130^{\circ}\text{F}$  ( $+55^{\circ}\text{C}$ ).

### 2-8. LINE VOLTAGE SELECTION

2-9. The counter is supplied from the factory with the rear panel line voltage switches set for 120 volt, 48 to 440 Hz operation. If any other supply voltage is to be used, change the rear panel switch settings as follows:

- a. Using a small screwdriver, a pencil, or other suitable tool, align the notches of the **LINE VOLTAGE SELECTOR** switches with the markings on the rear panel that correspond to the desired operating voltage (see Figure 2-1).

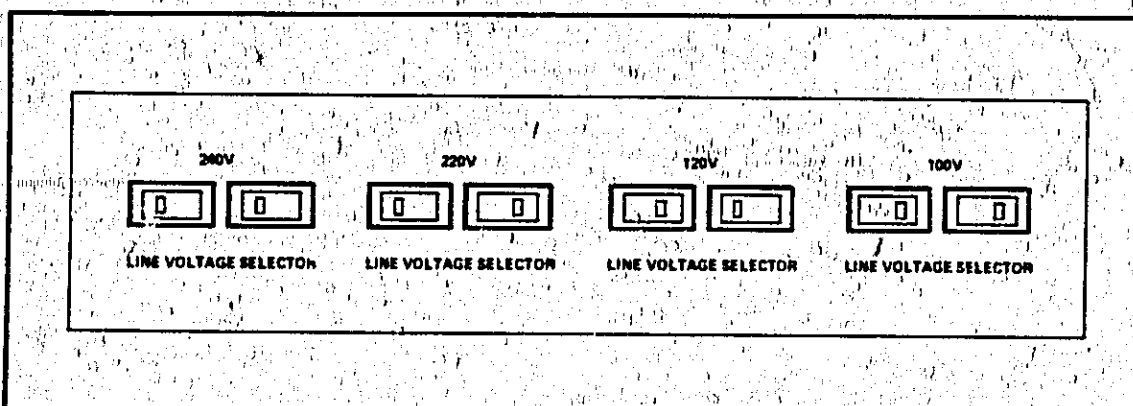

Figure 2-1. Line Voltage Selector Settings

Model 5381A  
Installation and Operation

- b. Ensure that the correct fuse is installed. Use a Listed, 0.500 ampere, slow-blow fuse for 100-volt or 120-volt operation or a Listed, 0.250 ampere, slow-blow fuse for 220-volt or 240-volt operation.

2-10. If the counter is to be used in the USA with a 220-240 volt, 48-440 Hz power source, use a power cord with a Listed connector of the type shown in Figure 2-2.

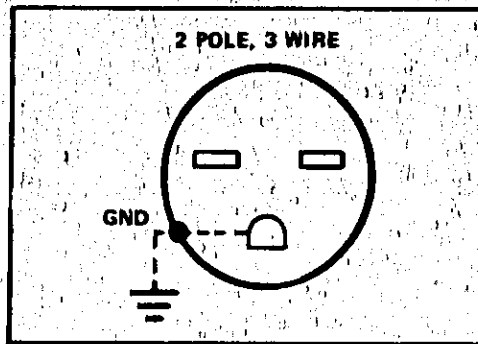

Figure 2-2. Power Cord Connector for 240-Volt Operation

**2-11. OPERATION**

2-12. Figures 2-3 and 2-4 describe the operation of each panel control, connector, and indicator. The following paragraphs describe proper cable and cable termination use, how to make ratio measurements with the counter, and how to optimize noise rejection with the ATTENUATOR.

**2-13. Cable and Termination Requirements**

2-14. To prevent miscounting due to noise, shielded cables should be used to make measurements. More specifically, a coaxial cable with a 50-ohm characteristic impedance and BNC connectors at each end are recommended for most measurements. At higher frequencies the 50-ohm cable becomes an important factor. Whenever the measured source has a 50-ohm output impedance (this is the case with most test oscillators), a 50-ohm feedthrough termination should be used. On the other hand, in cases where minimal source loading is desirable, the 50-ohm feedthrough termination should be omitted from the circuit. At frequencies up to approximately 10 MHz, and at all but the lowest signal levels, a 10:1 divider probe can be used to further reduce source loading.

**2-15. Ratio Measurements**

2-16. The counter will measure the ratio between the frequencies of two signals if one of the signals is applied to the rear-panel OSCILLATOR-EXT IN connector and the other signal is applied to the front-panel INPUT connector. Be sure to refer to Table 1-1 for signal level and frequency limits. The displayed value represents the ratio of one frequency to the other as shown by the following formula:

$$\frac{\text{freq at INPUT}}{\text{freq at OSCILLATOR-EXT IN}} = \frac{\text{Display Value}}{X}$$

where  $X = 1$  if GATE TIME is .1s  
 $10^3$  if GATE TIME is 1s  
 $10^6$  if GATE TIME is 10s

Note that in the above formula the term "X" changes by a factor of 1000 ( $10^3$ ) for each change in GATE TIME setting. GATE TIME, itself, changes "X" by a factor of 10, and the decimal point in the display shifts two places ( $10^2$ ) for a total of  $10^3$ . Note, also, that actual measurement time increases as the frequency applied to the OSCILLATOR-EXT IN connector decreases. If the frequency applied to the OSCILLATOR-EXT IN connector is 100 kHz, for example, and GATE TIME is set to 1s, actual measurement time will be 10 seconds.

**2-17. Optimizing Noise Rejection**

2-18. A measured signal may have a large harmonic content or noise from other sources. The presence of either can cause inaccurate or unstable displays from the counter. Measurement errors from these sources can be minimized or eliminated by proper use of the ATTENUATOR switch.

2-19. The ATTENUATOR should usually be set to "X100", then reduced, one step at a time, until a stable display is obtained. If the signal contains a high percentage of amplitude modulation, however, the above procedure may cause counting of only a portion of the cycles of the carrier signal. In these cases, the ATTENUATOR should be set to "X1" (be sure that the input amplitude does not exceed the limits specified in Table 1-1), then increased to "X10" or "X100" if this is possible without causing the displayed value to change or become unstable.

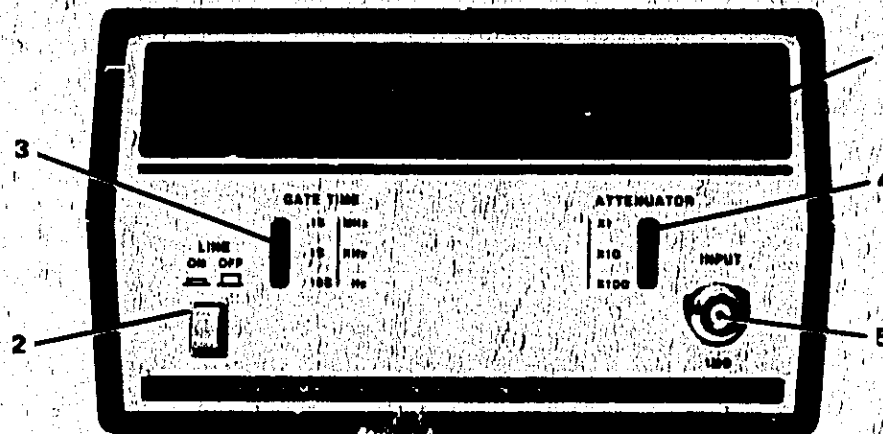

1. **Display:** Seven digits of LED (light-emitting diode) display are provided on the front panel. A decimal point illuminates in the proper position according to the setting of the GATE TIME switch, and an over-range indicator in the upper, left corner of the display illuminates when the counter overflows.
2. **LINE switch:** The ac power LINE switch is a push-on, push-off type; in the on position, the pushbutton is set further into the front panel.
3. **GATE TIME switch:** Gate time (measurement time) can be set at 0.1-second, 1-second, or 10 seconds with the GATE TIME switch. These positions give resolutions of 10 Hz, 1 Hz, and 0.1 Hz, respectively. If the GATE TIME switch is set to 1s, for example, it will take 1-second to make a measurement and the measured value will be displayed in 1 Hz increments. Manual resetting of the counter circuits occurs whenever the GATE TIME switch position is changed. Set the GATE TIME switch to provide the best compromise between measurement speed and resolution of the displayed value.
4. **ATTENUATOR switch:** The three-position attenuator switch provides for attenuation of input signals by factors of 10 and 100. The input signal is not attenuated when the switch is set to the "X1" position. The attenuator is used to extend the range of input signal levels that can be measured by the counter and to optimize noise rejection. Maximum sensitivity of the counter ranges from 25 millivolts rms with the attenuator set to "X1" to 2.5 volts rms with the attenuator set to "X100". If the amplitude of a measured signal is unknown or if signal noise causes the display to be unstable, set the ATTENUATOR to "X10" or "X100", then reduce the attenuation, if necessary, until a stable display is observed.

**CAUTION**

**BE SURE THAT THE MAXIMUM ALLOWABLE INPUT VOLTAGES AS GIVEN IN TABLE 1-1, SPECIFICATIONS, ARE NOT EXCEEDED. DAMAGE TO THE COUNTER MAY OTHERWISE RESULT.**

5. **INPUT connector:** Connect the signal to be measured to the BNC-type INPUT jack. Input impedance is 1.0 megohm.

Figure 2-3. Front Panel Operating Controls, Connectors, and Indicators

Model 5381A  
Installation and Operation

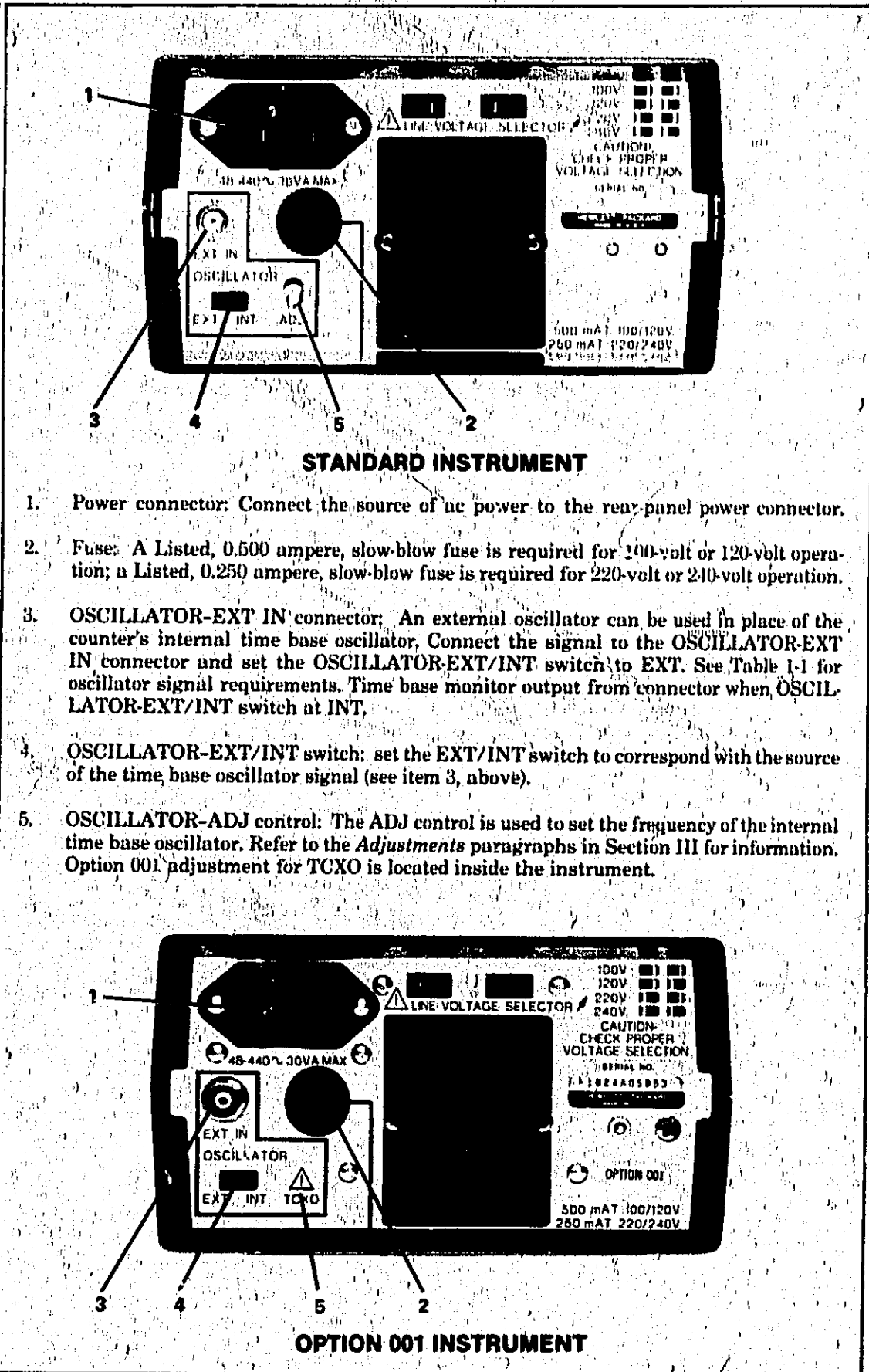

Figure 2-4. Rear-Panel Operating Controls and Connectors

**MAINTENANCE**

## SECTION III MAINTENANCE

### 3-1. INTRODUCTION

3-2. This section of the manual provides all information necessary to service the counter. The following topics are included:

- a. Theory of circuit operation.
- b. In-cabinet performance checks.
- c. Instrument access instructions.
- d. Preventive maintenance.
- e. General repair information.
- f. Adjustment procedures.
- g. Troubleshooting instructions.
- h. Replaceable parts lists.
- i. A schematic diagram with support information.

### 3-3. THEORY OF CIRCUIT OPERATION

3-3A. The following paragraphs cover the detailed operation of the particular circuits used in this counter. For a more general description of how a counter functions and the techniques used in counting, refer to HP Application Note 172 "The Fundamentals of Electronic Frequency Counters." This application note is available from any HP Sales Office.

3-4. The input limiter, the input amplifier, and the Schmitt trigger circuits (see the block diagram of Figure 3-1) condition the measured input signals and ensure that subsequent digital circuits receive pulses with uniform rise and fall times. When the time base circuits open the main gate, these pulses pass through the main gate and are accumulated in the decade counter circuits. After the gate time elapses and the main gate closes, the counted data is stored in the data latches. The multiplexer circuits supply this stored data, one digit at a time, to the LED display. The display scan circuits synchronize the multiplexer circuits with the display enable lines, and this ensures that the proper BCD data digit is placed on the multiplexed data lines when the associated LED display digit is enabled.

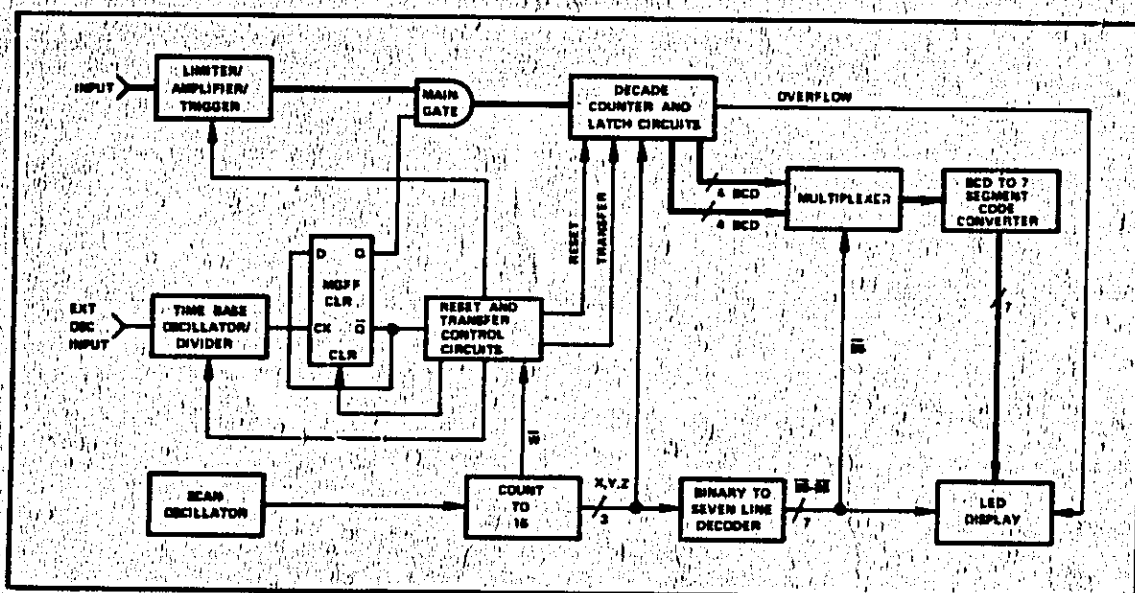

Figure 3-1. Simplified Block Diagram

### 3-5. Input Circuits

3-6. Diodes A1CR8 and A1CR9 limit input signal amplitude to a safe level for the subsequent circuits. Resistors A1R24 and A1R25 limit the current drawn by the diodes from high-voltage sources and, thus, reduce loading of these sources. Transistors A1Q4 and A1Q5 form a unity gain buffer amplifier that has a high input impedance, which reduces source loading, and a low output impedance to drive amplifier A1U14C. Amplifier A1U14C provides an approximate voltage gain of four and is direct coupled to A1U14B which functions as a Schmitt trigger. The balance adjustment, A1R19 provides control of the dc bias voltage applied to A1U14B which allows sensitivity to be optimized. The Schmitt trigger outputs are applied to differential amplifier A1Q1 and A1Q2, which provide sufficient gain to drive the main gate A1U7C.

### 3-7. Decade Counter, Latch, and Multiplexer Circuits

3-8. After the measured input signal passes through the main gate, A1U7C, it is accumulated in the decade counter circuits. Separate flip-flops within integrated circuits A1U6 and A1U10 count the least-significant decimal digit, and integrated circuit A1U9 counts the six more-significant digits. After the main gate closes, the TR (Transfer) signal transfers the data from A1U6 and A1U10 into storage latch A1U13. At the same time, the TR signal transfers the data in A1U9 into storage latches that are internal to A1U9. The stored data is then supplied to the display, one 4-bit BCD digit at a time, as controlled by the X, Y, Z, and  $\overline{S6}$  signal lines from the display scanner. Circuits within A1U9 control the multiplexing operation for the six most-significant digits; the X, Y, and Z lines provide the address code. The four gates within integrated circuit A1U12 gate the least significant digit onto the data lines when the  $\overline{S6}$  signal goes low. (When the  $\overline{S6}$  signal is low, the Z, Y, and X lines supply a binary code of 110 to integrated circuit A1U9, the decade counter. This causes all data output lines to go to a high logic level which, in turn, allows the outputs of the gates in A1U12 to control the data lines.)

### 3-9. Time Base Oscillator and Divider

3-10a. The time base oscillator and divider consists of integrated circuit A1U1 and associated components. The circuit provides an output at pin 1 (TP3), with a period that is determined by the oscillator crystal and the four-bit code applied to pins 11 through 14. A 1 MHz crystal is used, and the front-panel GATE TIME switch supplies the codes required to give a 0.1-second, 1-second, or 10-second gate time. The time base output at TP3 clocks the Main Gate flip-flop (MGFF), A1U3B, which controls the main gate, A1U7C. (Refer to the timing diagram of Figure 3-4.)

3-10b. With S1 in the INT (Internal) position, U16D receives an oscillator signal from either the option 001 oscillator or through Q6 from the OSC OUT pin (10) of U1. The oscillator signal is routed through U16A and U16B to the EXT INPUT pin (3) of U1. A portion of the oscillator signal is also passed through R30 and R4 to the rear panel OSC jack J2. U16C is disabled during this mode of operation.

3-10c. When S1 is in the EXT (External) position, U16D is disabled and signals enter the rear panel J2 and pass through U16C, U16A and enter U1 through U16B. R30, R28 and R4 bias pin 8 of U16. R30 provides positive feedback so that circuit functions as a Schmitt trigger.

### 3-11. Display Scanner

3-12. The display scanner consists of all the circuits necessary to drive the LED (light-emitting-diode) displays. An oscillator with a frequency of approximately 20 kHz (A1U4B and A1U2F) supplies the input to a four-bit counter (A1U8). The four outputs of the counter supply a continuously cycling binary code that is used both for display scanning and counter timing.

3-13. Integrated circuit A1U11 decodes the three most significant outputs (the X, Y, and Z lines) from the four-bit counter and supplies outputs on seven separate lines, one drive line for each of the seven display digits. The X, Y, and Z lines also are used as the address lines to A1U9, where they control the multiplexing of data. This synchronizes the data output with the sequential enabling of the display digits. Integrated circuit A2U1 converts the four data bits from BCD to the seven-

segment code required to drive the display. Data is supplied from circuit A2U1 to all seven display positions simultaneously, and the S0 through S6 lines enable only the single display position that corresponds to the data on the data lines at a given time. Transistors A2Q1 through A2Q7 provide sufficient current to drive the LED displays.

### 3-14. Reset and Transfer Control Circuits

3-15. The reset and transfer control circuits control the sequencing of the counter. (Refer to the timing diagram of Figure 3-4.) The Main Gate flip-flop (MGFF) opens when W and S6 signals combine to set A1U40(11) low. This clears A1U17B and releases the reset levels on A1U3B(13) and A1U1(6). The next clock pulse into A1U1 sets the OUTPUT line low and clocks the MGFF open. U1 pin 16 goes low again at the end of the gate time and clocks A1U3B closed. The positive-going transition on the Q output of A1U3B clocks A1U17B. The outputs of A1U17B reset A1U3B, A1U1, and A1U17A. The low Q output (pin 6) of the Reset Control flip-flop allows the W signal to control the output of gate A1U4C. (When the Q output is high, the output of gate A1U4C is always high.) The W, S4, S5, and S6 signals cause the following sequence of events to occur. (The W signal causes these events to occur during the middle of the S4, S5, and S6 signals to ensure that these outputs are stable.) First, when the W and S4 signals are low, the TR and TR signals are generated and used to transfer data from the decade counters to the storage latches. When the W and S5 signals are low, the RSC signal is generated. The RSC signal resets the decade counters and, through A1U14A, pre-sets the Schmitt trigger in the counter's input circuits. When the W and S6 signals are low, the Reset Control flip-flop and A1U17B clear. This allows the time base reset line (A1U1, pin 6) to return low and a new measurement to be made.

### 3-16. RECOMMENDED TEST EQUIPMENT

3-17. Test equipment recommended for maintaining the counter is listed in Table 3-1. Equipment with equivalent characteristics may be substituted for the recommended equipment.

Table 3-1. Recommended Test Equipment

Instrument Type	Required Characteristics	Recommended Instrument
Electronic Counter	1 MHz frequency measurements and high stability time base.	HP 5328A-001 for standard instrument. HP 5345A or HP 5328A-010 for Option 001.
VHF Oscillator	Range: 80 MHz	HP 3200B
Test Oscillator	Range: 10 Hz to 10 MHz Output: 2.5 Vrms	HP 651B
RF Millivoltmeter	Frequency: 20 MHz to 80 MHz Range: 25 mV rms to 50 mV rms	HP 411A or HP 3406A
50-Ohm Feed-thru	50-Ohm termination, male-to-female BNC connectors	HP 11048A
Logic Probe	Logic level measurements	HP 10525T
Oscilloscope	1 MHz measurements	HP 180A/1801A/1820A

### 3-18. IN-CABINET PERFORMANCE CHECK

3-19. Use the performance check in Table 3-2 to verify proper operation of all circuits within the counter. The check should be used when improper operation or nonconformance to specifications is suspected.

Table 3-2. In-Cabinet Performance Check

### 1. SENSITIVITY

Obtain the following test equipment:

HP 411A RF Millivoltmeter  
HP 651B Test Oscillator  
HP 3200B UHF Oscillator  
HP 11048A 50-Ohm Feed-Thru

- a. Set the counter's ATTENUATOR switch to X1.
- b. Connect the test equipment to the counter as shown below.

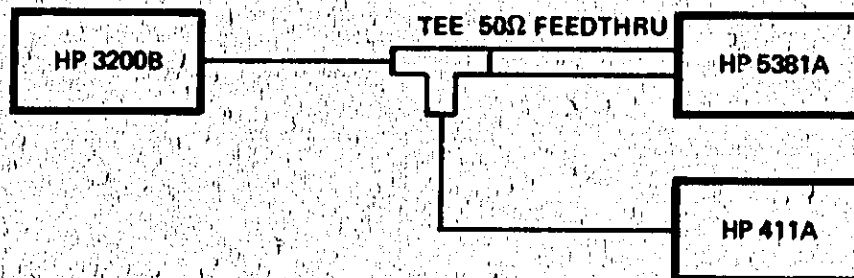

- c. Set the 3200B to provide an 80 MHz output at 50 mV rms as indicated on the 411A.
- d. Counter's display should indicate 80 MHz and displayed value should be stable.
- e. Set the 3200B to provide a 20 MHz output at 25 mV rms as indicated on the 411A.
- f. Counter's display should indicate 20 MHz and displayed value should be stable.
- g. Remove 3200B and 411A, and connect the 50Ω output of the 651B to the counter. Use a 50-ohm feed-thru at the counter's INPUT connector.
- h. Set the 651B to provide an output of 10 Hz at 50 mV rms.
- i. Counter's display should indicate 10 Hz and displayed value should be stable.
- j. Set the 651B to provide an output of 30 Hz at 25 mV rms.
- k. Counter's display should indicate 30 Hz and displayed value should be stable.

### 2. EXTERNAL OSCILLATOR INPUT

Obtain the following test equipment:

HP 651B Test Oscillator  
HP 11048A 50-Ohm Feed-Thru

- a. Set the counter's ATTENUATOR switch to X1, GATE TIME switch to .1s, and OSCILLATOR-EXT/INT switch to EXT.
- b. Connect the 50Ω output of the 651B to the counter's rear-panel OSCILLATOR-EXT IN connector through a Tee connector and a 50-ohm feed-thru termination.
- c. Connect a cable between the unused end of the Tee connector and the counter's front-panel INPUT connector.
- d. Set the 651B for an output of 2 MHz at 2.5 Vrms. The counter's display should be 01.00000 ±1 count.
- e. Set the 651B for an output of 10 kHz at 2.5 Vrms. The counter's display should be 01.00000 ±1 count.

Table 3-2. In-Cabinet Performance Check (Continued)

### 3. DISPLAY

Obtain the following test equipment:

HP 651B Test Oscillator  
HP 11048A 50-Ohm Feed-Thru

- a. With no signal applied, set the front-panel GATE TIME switch to each of its three settings. The decimal point should move to give the following displays:

00.00000 for .1s gate time,  
0000.000 for 1s gate time,  
000000.0 for 10s gate time.

- b. Connect the 651B to the counter's INPUT connector. Use the 50-ohm feed-thru at the counter-end of the cable.
- c. Adjust the 651B frequency and the counter GATE TIME switch until an eight has been observed in each of the seven display positions. This ensures that each display segment is operative.

### 4. OPTION 001 TIME BASE OSCILLATOR

- a. Obtain the following test equipment:

HP 5328A (Option 010) Universal Counter, or  
HP 5345A Electronic Counter (with oven oscillator)

- b. Set 5381A front panel controls as follows:

ATTENUATOR to X1  
GATE TIME switch to 10 s/Hz

- c. Set 5381A rear panel INT-EXT switch to INT.

- d. Connect a coaxial cable between the 5381A front panel INPUT connector and:

HP 5345A rear panel FREQ STD OUTPUT 10 MHz connector, or  
HP 5328A (Option 010) rear panel OSC connector

This inputs a high-stability 10 MHz reference to the 5381A.

- e. Check that 5381A displays  $0.000000.0 \text{ Hz} \pm 10.1 \text{ Hz}$ .  
If not, perform adjustment procedure in paragraph 3-33b.

## 3-20. INSTRUMENT ACCESS

3-21. Most maintenance operations required that the top and bottom covers be removed from the counter. Remove the covers according to the following procedure.

### WARNING

**DISCONNECT THE AC POWER CORD FROM THE COUNTER PRIOR TO REMOVING COVERS. EXPOSED TERMINALS WITHIN THE COUNTER (INCLUDING SEVERAL POINTS ON THE PRINTED-CIRCUIT BOARDS) CAN SUPPLY SUFFICIENT ENERGY TO CAUSE INJURY OR DEATH.**

- a. Position the instrument upside down and remove the four machine screws from the bottom of the instrument.
- b. Lift the bottom cover from the instrument, then remove the printed circuit (with the front and rear panels attached) by pulling the boards straight out of the top cover.
- c. Reassemble in reverse order of disassembly; ensure that the standoff spacers on top cover are aligned with the corresponding holes on the main circuit board.

### 3-22. PREVENTIVE MAINTENANCE

3-23. Periodically, perform the In-Cabinet Performance Check of Table 3-2 to verify proper operation of the counter. Additionally, whenever the covers are removed, check for broken or burned components, damaged wires, excess dust, etc.

### 3-24. GENERAL REPAIR

3-25. The following paragraphs provide general repair information for the counter.

3-26. **COMPONENT REPLACEMENT.** When replacing a circuit board component, use a low heat soldering iron. Heat must be used sparingly as damage to the circuit foil may otherwise occur. Mounting holes may be cleaned with a toothpick while heat is applied. After component removal and replacement, clean connections with a suitable cleaning solution.

3-27. **INTEGRATED CIRCUIT REPLACEMENT.** Two methods are recommended for removing integrated circuits:

- a. **Solder Gobbler.** Solder is removed from board by a soldering iron with a hollow tip that is connected to a vacuum source. The IC is removed intact, so it may be reinstalled if it is later proven not to be defective.
- b. **Clip Out.** This method is used when an IC is proven defective. Clip leads close to case, apply heat, and remove leads with long-nose pliers. Clean board holes with a toothpick and cleaning solution.

### 3-28. ADJUSTMENTS

3-29. The counter requires two circuit adjustments: 1) the input amplifier balance adjustment and 2) the time base oscillator adjustment. Perform the adjustments according to the following procedures.

#### 3-30. Amplifier Balance Adjustment

3-31. Adjust the input amplifier balance as follows:

- a. Remove top and bottom covers from the counter as described in Paragraph 3-20. Be sure to observe WARNING note in Paragraph 3-20.
- b. Connect the oscilloscope to TP6 on the A1 Main Board Assembly.
- c. Connect the test oscillator 50 $\Omega$  output to the front-panel INPUT connector (use a 50-ohm feed-through at the INPUT connector), and set the test oscillator to provide an output of approximately 30 mV rms at a frequency of 1 MHz.
- d. Connect ac power to the counter. Be sure to observe the WARNING note in Paragraph 3-20.
- e. Adjust potentiometer A1R19 until the oscilloscope shows that the signal at TP6 has a 50 percent duty cycle.
- f. Remove ac power from the counter, remove test equipment, and install the counter in the top and bottom covers.

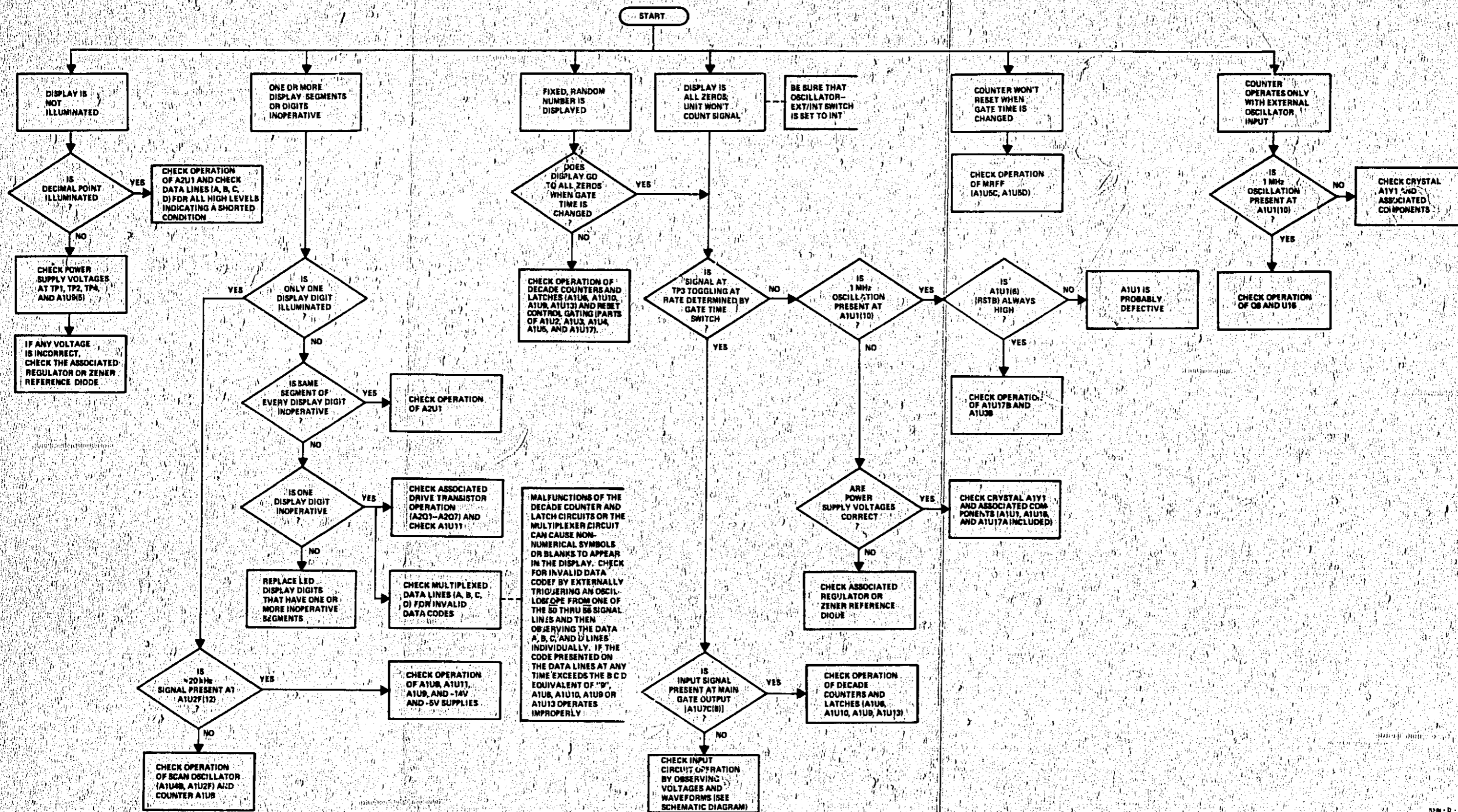

Figure 3-2. Troubleshooting Flow Chart

### 3-32. Oscillator Adjustment, Standard and Option 001

3-33a. Set the time base oscillator frequency in standard instrument, as follows:

- a. Connect the ac power to the counter, depress the front-panel LINE switch, and allow 5 minutes for the oscillator to stabilize.
- b. Connect the rear-panel oscillator output jack on the 5382A-001 (or equivalent, stable, 10 MHz source) to the counter's INPUT connector.
- c. Set the counter's GATE TIME switch to 1s and adjust the rear-panel OSCILLATOR ADJ. control until the counter display indicates exactly 10 MHz. Note that the over range indicator is lit and the most significant digit is not displayed (00.00000).
- d. Remove ac power and disconnect test equipment.

### 3-33b. Option 001 TCXO Oscillator Adjustment

#### NOTE

This adjustment must be made with the ambient temperature at 25°C.

- a. Disconnect ac power from 5381A and remove covers.

#### WARNING

**115/230 VOLT AC POWER IS AVAILABLE AT SEVERAL POINTS WHEN THE 5381A COVERS ARE REMOVED. EXERCISE EXTREME CARE WHEN WORKING INSIDE THE UNIT. PERSONAL INJURY OR DEATH MAY RESULT FROM CONTACT WITH HIGH-VOLTAGE CIRCUITS.**

- b. Connect ac power to 5381A and set the line switch to ON. Allow at least 5 minutes for the TCXO to stabilize.
- c. Using coaxial cable, connect 5381A EXTERNAL OSC IN jack to input of 5345A or 5328A Option 010 counter (for 5328A use, use 50Ω feed thru connector HP 11048C). Adjust 5345A or 5328A for 1 Hz resolution.
- d. Check the 25°C frequency offset stamped on the side of the TCXO assy A1U19.
- e. Adjust TCXO ADJ control so that the value displayed on the 5345A or 5328A equals 10 MHz plus the 25°C offset. For example, if + 4 Hz is stamped on the side of the TCXO, set TCXO ADJ for 10.000004 MHz reading on a 5345A.

### 3-34. TROUBLESHOOTING

3-35. Malfunctions of the counter circuits produce several symptoms of trouble. The troubleshooting flowchart of Figure 3-2 lists these symptoms and provides a sequential test to isolate the trouble to a component or small group of components. To troubleshoot the counter, find the observed symptom at the top of the flowchart and perform the indicated circuit checks.

3-36. Additional information in the form of a timing diagram, Figure 3-4, and waveform illustrations (with the schematic diagram) is provided to aid troubleshooting.

# PARTS LIST

### 3-37. REPLACEABLE PARTS

3-38. Table 3-3 lists parts used in the counter in alphanumeric order of their reference designations and provides the following information for each part. Miscellaneous parts are listed at the end of Table 3-3.

- a. Hewlett-Packard part number
- b. Description of part (see abbreviations)
- c. Total quantity used in the instrument
- d. Typical manufacturer of the part in a five-digit code (see list of manufacturers in Table 3-4).
- e. Manufacturer's part number.

### 3-39. Replacement LED Digital Display Units

3-40. The digital display LED units in each instrument are matched for uniform brightness. Correct replacement units to match the rest of the display units in a particular instrument can be identified by the part number on the display unit being replaced. Some are marked 5082-7731 or 1990-0457 with suffix letters of "C", "D", or "E". Refer to the listing below to determine the new equivalent part number for the correct replacement LED display unit.

FORMER PART NO.	NEW EQUIVALENT PART NO.
5080-7731C } 1990-0452C }	1990-0469
5082-7731D } 1990-0452D }	1990-0470
5082-7731E } 1990-0452E }	1990-0471



**ABBREVIATIONS**

DSB	= double sideband	MFR	= manufacturer	PIV	= peak inverse voltage	TFT	= thin-film transistor
DTI	= diode transistor logic	mg	= milligram	pk	= peak	TGL	= toggle
DVM	= digital voltmeter	MHz	= megahertz	PL	= phase lock	THD	= thred
ECL	= emitter coupled logic	mH	= millihenry	PLD	= phase lock oscillator	THRU	= through
EMF	= electromotive force	mho	= mho	PM	= phase modulation	TI	= titanium
EDP	= electronic data processing	MIN	= minimum	PNA	= positive-negative-positive	TOI	= tolerance
ELECT	= electrolytic	min'	= minute (time)	PNI	= positive-negative-positive	TRIM	= trimmer
ENCAP	= encapsulated	MINAT	= miniature	P/O	= part of	TSTR	= transistor
EXT	= external	mm	= millimeter	POLY	= polystyrene	TTR	= transistor-transistor logic
F	= farad	MOD	= modulator	PORC	= porcelain	TV	= television
FET	= field-effect transistor	MOM	= momentary	POS	= positive; position(s) (used in parts list)	TVI	= television interference
FF	= flip-flop	MOS	= metal-oxide semiconductor	POSN	= position	TWT	= traveling wave tube
FH	= flat head	ms	= millisecond	POT	= potentiometer	U	= micro (10 <sup>-6</sup> ) (used in parts list)
FLH	= flilster head	MTG	= mounting	pp	= peak-to-peak	UF	= microfarad (used in parts list)
FM	= frequency modulation	MTR	= meter (indicating device)	PP	= peak-to-peak (used in parts list)	UHF	= ultrahigh frequency
FP	= front panel	mV	= millivolt	PPM	= pulse-position modulation	UNREG	= unregulated
FREQ	= frequency	mVdc	= millivolt, dc	PREAMPL.	= preamplifier	V	= volt
FXD	= fixed	mVdc	= millivolt, dc	PRF	= pulse-repetition frequency	VA	= voltampere
G	= gram	mVpk	= millivolt, peak	PRR	= pulse-repetition rate	Vac	= volts, ac
GE	= germanium	mVpp	= millivolt, peak-to-peak	PT	= picosecond	VAR	= variable
GHz	= gigahertz	mVrms	= millivolt, rms	PTM	= pulse-time modulation	VCD	= voltage-controlled oscillator
GL	= glass	mW	= milliwatt	PWM	= pulse-width modulation	Vdc	= volts, dc
GN(D)	= grounded	MUX	= multiplex	PWV	= peak working voltage	VDCW	= volts, dc, working (used in parts list)
H	= hour	MY	= mylar	RC	= resistance-capacitance	V(F)	= volts, filtered
HET	= heterodyne	μA	= microampere	RECT	= rectifier	VFO	= variable-frequency oscillator
HEX	= hexagonal	μF	= microfarad	REF	= reference	VHF	= very-high frequency
HD	= head	μH	= microhenry	REG	= regulated	Vpk	= volts, peak
HDW	= hardware	μHh	= microhenry	REPL.	= replaceable	Vpp	= volts, peak-to-peak
HF	= high frequency	μhho	= microhenry	RF	= radio frequency	Vrms	= volts, rms
HG	= mercury	μs	= microsecond	RFI	= radio frequency interference	VSWR	= voltage standing wave ratio
HI	= high	μV	= microvolt	RH	= round head; right hand	VTD	= voltage-tuned oscillator
HP	= Hewlett-Packard	μVdc	= microvolt, dc	RIAC	= resistance-inductance-capacitance	VTVM	= vacuum-tube voltmeter
HPF	= high pass filter	μVpk	= microvolt, peak	RMO	= rack mount only	V(X)	= volts, switched
HR	= hour (used in parts list)	μVpp	= microvolt, peak-to-peak	RND	= round	W	= watt
HV	= high voltage	μVrms	= microvolt, rms	RNM	= read-only memory	W/	= with
Hr	= Hertz	μW	= microwatt	RNP	= normally open	WV	= working inverse voltage
IC	= integrated circuit	nA	= nanoampere	RNW	= reverse working voltage	WW	= wirewound
ID	= inside diameter	NC	= no connection	S	= scattering parameter	W(D)	= without
IF	= intermediate frequency	N/C	= normally closed	S	= second (time)	YIG	= yttrium-iron-garnet characteristic impedance
IMPG	= impregnated	NE	= neon	S	= second (plane angle)	Zo	= characteristic impedance
in	= inch	NEG	= negative	S	= slow-blow (fuse) (used in parts list)		
INCD	= incandescent	nF	= nanofarad	SCR	= silicon controlled rectifier; screw		
INCL.	= include(s)	NI PL	= nickel plate	SE	= selenium		
INP	= input	N/D	= normally open	SECT	= sections		
INS	= insulation	NOM	= nominal	SEMICON	= semiconductor		
INT	= internal	NPN	= negative-positive-negative	SHF	= superhigh frequency		
kg	= kilogram	NPO	= negative-positive zero (zero temperature coefficient)	SI	= silicon		
kHz	= kilohertz	NRFR	= not recommended for field replacement	SIL	= silver		
kΩ	= kilohm	NSR	= not separately replaceable	SL	= slide		
kV	= kilovolt	ns	= nanosecond	SNR	= signal-to-noise ratio		
lb	= pound	nW	= nanowatt	SPT	= single-pole, double-throw		
lA	= inductance-capacitance	ODD	= order by description	SPST	= single-pole, single-throw		
LED	= light-emitting diode	OD	= outside diameter	SSB	= single sideband		
LF	= low frequency	OH	= oval head	SST	= stainless steel		
LG	= long	OP AMPL.	= operational amplifier	STL	= steel		
LH	= left hand	OSC	= oscillator	SQ	= square		
LIM	= limit	OX	= oxide	SWR	= standing-wave ratio		
LJN	= linear taper (used in parts list)	oz	= ounce	SYNC	= synchronize		
LJN	= linear	P	= peak (used in parts list)	T	= time (slow-blow fuse)		
lin	= linear	PAM	= pulse-amplitude modulation	TA	= tantalum		
LK	= lock washer	PC	= printed circuit	TC	= temperature compensating		
LQ	= low; local oscillator	PCM	= pulse-code modulation; pulse-count modulation	TD	= time delay		
LOG	= logarithmic taper (used in parts list)	PDM	= pulse-duration modulation	TERM	= terminal		
log	= logarithmic	pF	= picofarad				
LPF	= low pass filter	PH BRZ	= phosphor bronze				
LV	= low voltage	PHI.	= Phillips				
m	= meter (distance)	PIN	= positive-intrinsic-negative				
mA	= milliamperes						
MAX	= maximum						
MD	= megohm						
MEG	= meg (10 <sup>6</sup> ) (used in parts list)						
MET FILM	= metal film						
MET OX	= metal oxide						
MF	= medium frequency; microfarad (used in parts list)						

**NOTE**  
All abbreviations in the parts list will be in upper case.

**MULTIPLIERS**

Abbreviation	Prefix	Multiple
T	tera	10 <sup>12</sup>
G	giga	10 <sup>9</sup>
M	mega	10 <sup>6</sup>
k	kilo	10 <sup>3</sup>
d	deka	10 <sup>1</sup>
da	deci	10 <sup>-1</sup>
c	centi	10 <sup>-2</sup>
m	milli	10 <sup>-3</sup>
μ	micro	10 <sup>-6</sup>
n	nano	10 <sup>-9</sup>
p	pico	10 <sup>-12</sup>
f	femto	10 <sup>-15</sup>
a	atto	10 <sup>-18</sup>

Table 3-3. Replaceable Parts, Standard Instrument

Reference Designation	HP Part Number	Qty	Description	Mfr Code	Mfr Part Number
A1	05381-60006	1	BOARD ASSEMBLY, MAIN (STANDARD INST.) SERIES 1624A	28480	05381-60006
A1C1	0180-0480	1	CAPACITOR-FXD 4500UF±75-10E 25VDC AL	56289	36DX452G025AA2A
A1C2	0121-0105	1	CAPACITOR-V TRMR-CER 9/35PF 200V PC-MTG	00265	30A324 9/35PF N650
A1C3	0160-2265	1	CAPACITOR-FXD 22PF ±5E 500MVDC CER	28480	0160-2265
A1C4	0160-2055	13	CAPACITOR-FXD .01UF ±80-20E 100MVDC CER	28480	0160-2055
A1C5	0160-0192	1	CAPACITOR-FXD 68PF ±5E 300MVDC MICA *FACTORY SELECTED PART	72136	DM15E680J0300WVICH
A1C6	0180-0061	1	CAPACITOR-FXD 100UF±75-10E 16VDC AL	56289	30D107G016DCZ
A1C7	0180-0094	1	CAPACITOR-FXD 100UF±75-10E 25VDC AL NOT ASSIGNED	56289	30D107G025D002
A1C8	0160-2055	1	CAPACITOR-FXD .01UF ±80-20E 100MVDC CER	28480	0160-2055
A1C9	0160-2055	1	CAPACITOR-FXD .01UF ±80-20E 100MVDC CER	28480	0160-2055
A1C10	0160-2055	1	CAPACITOR-FXD .01UF ±80-20E 100MVDC CER	28480	0160-2055
A1C11	0180-0291	2	CAPACITOR-FXD 1UF±10E 35VDC TA	56289	150D105XV035A2
A1C12	0160-2055	1	CAPACITOR-FXD .01UF ±80-20E 100MVDC CER	28480	0160-2055
A1C13	0160-2055	1	CAPACITOR-FXD .01UF ±80-20E 100MVDC CER	28480	0160-2055
A1C14	0160-2055	1	CAPACITOR-FXD .01UF ±80-20E 100MVDC CER	28480	0160-2055
A1C15	0180-0184	4	CAPACITOR-FXD 60UF±20E 6VDC TA	56289	150D60X006B2
A1C16	0160-2055	1	CAPACITOR-FXD .01UF ±80-20E 100MVDC CER	28480	0160-2055
A1C17	0160-2055	1	CAPACITOR-FXD .01UF ±80-20E 100MVDC CER	28480	0160-2055
A1C18	0160-2055	1	CAPACITOR-FXD .01UF ±80-20E 100MVDC CER	28480	0160-2055
A1C19	0180-0106	1	CAPACITOR-FXD 60UF±20E 6VDC TA	56289	150D60X006B2
A1C20	0160-2055	1	CAPACITOR-FXD .01UF ±80-20E 100MVDC CER	28480	0160-2055
A1C21	0180-0291	1	CAPACITOR-FXD 1UF±10E 35VDC TA	56289	150D105XV035A2
A1C22	0180-0184	1	CAPACITOR-FXD 60UF±20E 6VDC TA	56289	150D60X006B2
A1C23	0180-0184	1	CAPACITOR-FXD 60UF±20E 6VDC TA	56289	150D60X006B2
A1C24	0150-0072	1	CAPACITOR-FXD 250PF ±5E 100MVDC CER	28480	0150-0072
A1C25	0160-0204	1	CAPACITOR-FXD 47PF ±5E 500MVDC MICA	72136	DM15E470J0500WVICH
A1C26	0160-2055	1	CAPACITOR-FXD .01UF ±80-20E 100MVDC CER	28480	0160-2055
A1C27	0160-2055	1	CAPACITOR-FXD .01UF ±80-20E 100MVDC CER	28480	0160-2055
A1C28	0160-2055	1	CAPACITOR-FXD .01UF ±80-20E 100MVDC CER	28480	0160-2055
A1C29	1901-0028	1	DIODE-MULTI PHASE BRIDGE RECTIFIER	04713	MD4922-3
A1C30	1901-0040	4	DIODE-SWITCHING 30V 50MA 2MS DO-35	28480	1901-0040
A1C31	1901-0040	1	DIODE-SWITCHING 30V 50MA 2MS DO-35	28480	1901-0040
A1C32	1901-0028	1	DIODE-FRM RECT 400V 750MA DO-29	04713	581358-9
A1C33	1902-0579	1	DIODE-ZNR 5.11V 5E DO-15 PO-1W TC=+009E	28480	1902-0579
A1C34	1902-0555	1	DIODE-ZNR 13V 5E DO-15 PO-1W TC=+04E	28480	1902-0555
A1C35	1901-0040	1	DIODE-SWITCHING 30V 50MA 2MS DO-35	28480	1901-0040
A1C36	1901-0040	1	DIODE-SWITCHING 30V 50MA 2MS DO-35	28480	1901-0040
A1C37	1901-0040	1	DIODE-SWITCHING 30V 50MA 2MS DO-35	28480	1901-0040
A1C38	1901-0040	1	DIODE-SWITCHING 30V 50MA 2MS DO-35	28480	1901-0040
A1C39	1901-0040	1	DIODE-SWITCHING 30V 50MA 2MS DO-35	28480	1901-0040
A1E1	9100-2251	1	COIL-FXD MOLDED RF CHOKE .22UH 10E	24224	10/220
A1E2	9140-0137	1	COIL-WLD 120V 5E Q=60 .190X.44LG SRF=3MMZ	24224	10/220
A1G1	1855-0015	3	TRANSISTOR PNP 5E PD=200MW FT=500MHZ	28480	1855-0015
A1G2	1855-0015	1	TRANSISTOR PNP 5E PD=200MW FT=500MHZ	28480	1855-0015
A1G3	1855-0071	1	TRANSISTOR PNP 5E PD=300MW FT=200MHZ	28480	1855-0071
A1G4	1855-0015	1	TRANSISTOR PNP 5E PD=200MW FT=500MHZ	28480	1855-0015
A1G5	1855-0081	2	TRANSISTOR J-FET 2N5245 N-CHAN D-MODE 5E	01295	2N5245
A1G6	1855-0081	1	TRANSISTOR J-FET 2N5245 N-CHAN D-MODE 5E	01295	2N5245
A1H1	0683-2435	1	RESISTOR 24K 5E .25W FC TC=+400/+800	01121	CB2435
A1H2	0683-2355	1	RESISTOR 3.3K 5E .25W FC TC=+400/+800	01121	CB2355
A1H3	0683-2655	1	RESISTOR 5.4K 5E .25W FC TC=+400/+800	01121	CB2655
A1H4	0761-0022	1	RESISTOR 620 5E 1W MO TC=0/+200	24546	FP32-1-T00-621-J
A1H5	0761-0042	1	RESISTOR 68 5E 1W MO TC=0/+200	24546	FP32-1-T00-68W-J
A1H6	0683-3315	1	RESISTOR 330 5E .25W FC TC=+400/+800	01121	CB3315
A1H7	0683-1215	2	RESISTOR 120 5E .25W FC TC=+400/+800	01121	CB1215
A1H8	0683-0125	1	RESISTOR 5.1K 5E .25W FC TC=+400/+700	01121	CB5125
A1H9	0683-1215	1	RESISTOR 120 5E .25W FC TC=+400/+800	01121	CB1215
A1H10	0683-1525	1	RESISTOR 1.5K 5E .25W FC TC=+400/+700	01121	CB1525
A1H11	0683-2225	1	RESISTOR 2.2K 5E .25W FC TC=+400/+700	01121	CB2225
A1H12	0683-7606	1	RESISTOR 75 5E .25W FC TC=+400/+800	01121	CB7606
A1H13	0683-2205	1	RESISTOR 22 5E .25W FC TC=+400/+800	01121	CB2205
A1H14	0683-3115	3	RESISTOR 310 5E .25W FC TC=+400/+800	01121	CB3115
A1H15	0683-2015	1	RESISTOR 200 5E .25W FC TC=+400/+800	01121	CB2015
A1H16	0683-3315	3	RESISTOR 330 5E .25W FC TC=+400/+800	01121	CB3315
A1H17	0683-3315	1	RESISTOR 330 5E .25W FC TC=+400/+800	01121	CB3315
A1H18	0683-3315	1	RESISTOR 330 5E .25W FC TC=+400/+800	01121	CB3315
A1H19	2100-3210	1	RESISTOR-TRMR 10K 10E C TOP-ADJ 1-TRM	32997	3306P-V4-10J
A1H20	0683-1045	1	RESISTOR 100K 5E .25W FC TC=+400/+800	01121	CB1045
A1H21	0683-2025	5	RESISTOR 2K 5E .25W FC TC=+400/+700	01121	CB2025
A1H22	0683-2025	1	RESISTOR 2K 5E .25W FC TC=+400/+700	01121	CB2025
A1H23	1810-0125	1	NETWORK-RES P-PIN-SIP .125-PIN-SPCC	56289	200C-1810-CNR
A1H24	0683-3105	1	RESISTOR 31 5E .5W CC TC=0/+12	01121	CB3105
A1H25	0683-3345	1	RESISTOR 330K 5E .25W FC TC=+400/+900	01121	CB3345

See paragraph 3-41 for ordering information

Table 3-3. Replaceable Parts, Standard Instrument (Cont' d)

Reference Designation	HP Part Number	Qty	Description	Mfr Code	Mfr Part Number
A1R26	0683-3115	1	RESISTOR 510 5% .25W FC TC=400/+600	01121	CB5115
A1R27	0683-3115	1	RESISTOR 510 5% .25W FC TC=400/+600	01121	CB5115
A1R28	0683-3325	1	RESISTOR 3.3K 5% .25W FC TC=400/+700	01121	CB3325
A1R29	0683-2025	1	RESISTOR 2K 5% .25W FC TC=400/+700	01121	CB2025
A1R30	0683-4725	1	RESISTOR 4.7K 5% .25W FC TC=400/+700	01121	CB4725
A1S1	0683-2025	1	RESISTOR 2K 5% .25W FC TC=400/+700	01121	CB2025
A1S2	0683-2025	1	RESISTOR 2K 5% .25W FC TC=400/+700	01121	CB2025
A1S3	3101-1977	1	SWITCH-5L DPDT-NS SUBMIN .5A 125VAC/DC NOT ASSIGNED	28480	3101-1977
A1S4	3101-0680	1	SWITCH-PS DPDT ALYNE 4A 250VAC	28480	3101-0680
A1U1	1820-1180	1	IC, DIGITAL	28480	1820-1180
A1U2	1820-0174	1	IC-DIGITAL SN7404N TTL HEX 1	01295	SN7404N
A1U3	1820-0693	1	IC-DIGITAL SN74574N TTL 5 DUAL	01295	SN74574N
A1U4	1820-0661	1	IC-DIGITAL SN7432N TTL QUAD 2 OR	01295	SN7432N
A1U5	1820-0328	1	IC-DIGITAL SN7402N TTL QUAD 2 NOR	01295	SN7402N
A1U6	1820-0629	2	IC-DIGITAL SN74512N TTL 5 DUAL J-K	01295	SN74512N
A1U7	1820-0681	1	IC-DIGITAL SN74500N TTL 5 QUAD 2 NAND	01295	SN74500N
A1U8	1820-0699	1	IC-DIGITAL SN7493N TTL BIN ASYNCHRO	01295	SN7493N
A1U9	1820-0634	1	IC-DIGITAL MOS DECD	28480	1820-0634
A1U10	1820-0629	1	IC-DIGITAL SN74512N TTL 5 DUAL J-K	01295	SN74512N
A1U11	1820-0491	1	IC-DIGITAL SN74145N TTL 4 BCD-TO-DEC	01295	SN74145N
A1U12	1820-0269	1	IC-DIGITAL SN7403N TTL QUAD 2 NAND	01295	SN7403N
A1U13	1820-0301	1	IC-DIGITAL SN7475N TTL D-TYPE	01295	SN7475N
A1U14	1820-1224	1	IC-DIGITAL MC1021AP ECL TTL 2 LINE RCVR	04713	MC1021AP
A1U15	1820-0122	1	IC V REGULATOR	07263	7805UC
A1U16	1820-1144	1	IC-DIGITAL SN74LS02N TTL LS QUAD 2 NOR	01295	SN74LS02N
A1U17	1820-1112	1	IC-DIGITAL SN74LS74N TTL LS DUAL	01295	SN74LS74N
A1X1	1200-0473	1	SOCKET-IC 16-CONT DIP-SLDR	28480	1200-0473
A1Y1	0410-0551	1	CRYSTAL, QUARTZ, 1MHz	28480	0410-0551
A2	05381-60082	1	BOARD ASSEMBLY, DISPLAY (SERIES 1824)	28480	05381-60082
A2C1	0160-0169	1	CAPACITOR-FXD 470PF +-5% 300VDC NICA	72158	DW15F471J0300WVICR
A2C2	0160-0182	1	CAPACITOR-FXD 47PF +-5% 300VDC NICA	28480	0160-0182
A2C3	0160-2254	1	CAPACITOR-FXD 7.5PF +-25% 500VDC CER	28480	0160-2254
A2C4	0160-0194	1	CAPACITOR-FXD .015UF +-10% 200VDC POLYE	56289	292P15392
A2C5	0160-0166	1	CAPACITOR-FXD 80UF +-20% 6VDC TA	56289	1500406R000082
A2C6	1901-0040	1	DIODE-SWITCHING 30V 50MA 2MS DO-35	28480	1901-0040
A2D1	1990-0452	7	DISPLAY NUM SEG 1 CHAR .3 IN HIGH	28480	1990-0452
A2D2	1990-0452	7	DISPLAY NUM SEG 1 CHAR .3 IN HIGH	28480	1990-0452
A2D3	1990-0452	7	DISPLAY NUM SEG 1 CHAR .3 IN HIGH	28480	1990-0452
A2D4	1990-0452	7	DISPLAY NUM SEG 1 CHAR .3 IN HIGH	28480	1990-0452
A2D5	1990-0452	7	DISPLAY NUM SEG 1 CHAR .3 IN HIGH	28480	1990-0452
A2D6	1990-0452	7	DISPLAY NUM SEG 1 CHAR .3 IN HIGH	28480	1990-0452
A2D7	1990-0452	7	DISPLAY NUM SEG 1 CHAR .3 IN HIGH	28480	1990-0452
A2E1	1251-3768	21	CONTACT-COMM U/M POST TYPE MALE DP5LDR	28480	1251-3768
A2E2	1251-3768	21	CONTACT-COMM U/M POST TYPE MALE DP5LDR	28480	1251-3768
A2E3	1251-3768	21	CONTACT-COMM U/M POST TYPE MALE DP5LDR	28480	1251-3768
A2E4	1251-3768	21	CONTACT-COMM U/M POST TYPE MALE DP5LDR	28480	1251-3768
A2E5	1251-3768	21	CONTACT-COMM U/M POST TYPE MALE DP5LDR	28480	1251-3768
A2E6	1251-3768	21	CONTACT-COMM U/M POST TYPE MALE DP5LDR	28480	1251-3768
A2E7	1251-3768	21	CONTACT-COMM U/M POST TYPE MALE DP5LDR	28480	1251-3768
A2E8	1251-3768	21	CONTACT-COMM U/M POST TYPE MALE DP5LDR	28480	1251-3768
A2E9	1251-3768	21	CONTACT-COMM U/M POST TYPE MALE DP5LDR	28480	1251-3768
A2E10	1251-3768	21	CONTACT-COMM U/M POST TYPE MALE DP5LDR	28480	1251-3768
A2E11	1251-3768	21	CONTACT-COMM U/M POST TYPE MALE DP5LDR	28480	1251-3768
A2E12	1251-3768	21	CONTACT-COMM U/M POST TYPE MALE DP5LDR	28480	1251-3768
A2E13	1251-3768	21	CONTACT-COMM U/M POST TYPE MALE DP5LDR	28480	1251-3768
A2E14	1251-3768	21	CONTACT-COMM U/M POST TYPE MALE DP5LDR	28480	1251-3768
A2E15	1251-3768	21	CONTACT-COMM U/M POST TYPE MALE DP5LDR	28480	1251-3768
A2E16	1251-3768	21	CONTACT-COMM U/M POST TYPE MALE DP5LDR	28480	1251-3768
A2E17	1251-3768	21	CONTACT-COMM U/M POST TYPE MALE DP5LDR	28480	1251-3768
A2E18	1251-3768	21	CONTACT-COMM U/M POST TYPE MALE DP5LDR	28480	1251-3768
A2E19	1251-3768	21	CONTACT-COMM U/M POST TYPE MALE DP5LDR	28480	1251-3768
A2E20	1251-3768	21	CONTACT-COMM U/M POST TYPE MALE DP5LDR	28480	1251-3768
A2E21	1251-3768	21	CONTACT-COMM U/M POST TYPE MALE DP5LDR	28480	1251-3768
A2J1	1250-1163	1	CONNECTOR-HP DMC FEM 5GL MDRS BR	28480	1250-1163
A2L1	9100-1620	1	COIL-FXD MOLDED RF CHOKER 15UH 100	24226	15/152
A2Q1	1853-0318	7	TRANSISTOR PNP SI PD=500MW FT=60MHZ	04713	MP56562
A2Q2	1853-0318	7	TRANSISTOR PNP SI PD=500MW FT=60MHZ	04713	MP56562
A2Q3	1853-0318	7	TRANSISTOR PNP SI PD=500MW FT=60MHZ	04713	MP56562
A2Q4	1853-0318	7	TRANSISTOR PNP SI PD=500MW FT=60MHZ	04713	MP56562
A2Q5	1853-0318	7	TRANSISTOR PNP SI PD=500MW FT=60MHZ	04713	MP56562

See paragraph 3-41 for ordering information

Table 3-3. Replaceable Parts, Standard Instrument (Continued)

Reference Designation	HP Part Number	Qty	Description	Mfr Code	Mfr Part Number
A206	1053-0918		TRANSISTOR PNP 51 PD=500MHZ FT=60MHZ	04713	MP56562
A207	1053-0918		TRANSISTOR PNP 51 PD=500MHZ FT=60MHZ	04713	MP56562
A2R1	0483-9125	1	RESISTOR 9.1K 5% .25W FC TC=-400/+700	01121	CB4715
A2R2	0483-9135	1	RESISTOR 91K 5% .25W FC TC=-400/+800	01121	CB4715
A2R3	0483-9145	1	RESISTOR 910K 5% .25W FC TC=-800/+900	01121	CB4715
A2R4	1810-0076	1	NETWORK-RES 9-PIN-SIP 1800Ω/SECTION	28480	1810-0076
A2R5	0483-4715	7	RESISTOR 470 5% .25W FC TC=-400/+800	01121	CB4715
A2R6	0483-4715		RESISTOR 470 5% .25W FC TC=-400/+800	01121	CB4715
A2R7	0483-4715		RESISTOR 470 5% .25W FC TC=-400/+800	01121	CB4715
A2R8	0483-4715		RESISTOR 470 5% .25W FC TC=-400/+800	01121	CB4715
A2R9	0483-4715		RESISTOR 470 5% .25W FC TC=-400/+800	01121	CB4715
A2R10	0483-4715		RESISTOR 470 5% .25W FC TC=-400/+800	01121	CB4715
A2R11	0483-4715		RESISTOR 470 5% .25W FC TC=-400/+800	01121	CB4715
A2R12	0483-4705	21	RESISTOR 47 5% .25W FC TC=-400/+500	01121	CB4705
A2R13	0483-4705		RESISTOR 47 5% .25W FC TC=-400/+500	01121	CB4705
A2R14	0483-4705		RESISTOR 47 5% .25W FC TC=-400/+500	01121	CB4705
A2R15	0483-4705		RESISTOR 47 5% .25W FC TC=-400/+500	01121	CB4705
A2R16	0483-4705		RESISTOR 47 5% .25W FC TC=-400/+500	01121	CB4705
A2R17	0483-4705		RESISTOR 47 5% .25W FC TC=-400/+500	01121	CB4705
A2R18	0483-4705		RESISTOR 47 5% .25W FC TC=-400/+500	01121	CB4705
A2R19	0483-4705		RESISTOR 47 5% .25W FC TC=-400/+500	01121	CB4705
A2R20	0483-4705		RESISTOR 47 5% .25W FC TC=-400/+500	01121	CB4705
A2R21	0483-4705		RESISTOR 47 5% .25W FC TC=-400/+500	01121	CB4705
A2R22	0483-4705		RESISTOR 47 5% .25W FC TC=-400/+500	01121	CB4705
A2E1	3101-1598	2	SWITCH-SL DPST-NS MINTR 1A 125VAC PC	28480	3101-1598
A2E2	3101-1598		SWITCH-SL DPST-NS MINTR 1A 125VAC PC	28480	3101-1598
A2U1	1820-1097	1	IC SN74 468M DECODER	01295	SN74468M
CHASSIS & MISCELLANEOUS PARTS					
C1	0160-3043	1	CAPACITOR-FXD 5000PF/500VPP ±20%	28480	0160-3043
F1	2110-0000	1	FUSE .5A 125V SLO-BLD 1.25X.25 UL (FOR 100/125V OPERATION)	75915	313-500
F2	2110-0201	1	FUSE .25A 250V SLO-BLD 1.25X.25 UL IEC (FOR 220/240V OPERATION)	75915	313-2505
J1	1251-2357	1	CONNECTOR-AC PUR HP-9 MALE PLG MTC	28480	1251-2357
J2	1250-0003	1	CONNECTOR-RF BNC FEM SGL HOLE PR	24991	28JR-130-1
S1			NOT ASSIGNED		
S2	3101-1036	1	SWITCH-SL 2-SPST-NS STD 1.5A 250VAC SLD	82389	11E-1036
T1	9100-3039	1	TRANSFORMER, POWER	28480	9100-3039
W1	8120-1378	1	CORD SET, GRAY 3CONDUCTOR	28480	8120-1378
XPF	2110-0464	1	FUSEHOLDER-EXTR POST 20A 300V UL/IEC INCLUDES:	75915	345002-01D
	2110-0465	1	FUSEHOLDER-EXTR POST UL/IEC .25X1.25FUSE	28480	2110-0465
	2950-0054	1	NUT-MED-DIM-CHAN 1/2-20-THD .125-TNK	28480	2950-0054
	0360-0001	1	TERMINAL-LUG-SLDR & SCR .141/.084 ID	78452	920
	0370-0914	1	BEZEL-PUSHBUTTONS KNDR, JAGE GRAY	28480	0370-0914
	0370-2006	1	PUSHBUTTON(SOLID GRAY)	28480	0370-2006
	0510-0002	1	PRESS-IN NUT 6-32 .062-LG	28480	0510-0002
	0510-0076	1	NUT-SHMET 6-32-THD .63-WD STL	78553	0510-0076
					0599-632-243
	5040-7032	1	FOOT	28480	5040-7032
	05301-20005	1	STAND, TILT	28480	05301-20005
	05301-40001	1	FOOT	28480	05301-40001
	05301-00001	1	PANEL, FRONT	28480	05301-00001
	05382-00002	1	PANEL, REAR (STANDARD INSTRUMENT)	28480	05382-00002
	05381-00003	1	PANEL, REAR (OPTION 001 UNLY)	28480	05381-00003
	05381-20003	1	COVER, TOP	28480	05381-20003
	05381-20004	1	COVER, BOTTOM	28480	05381-20004
	05381-20005	4	STANDOFF	28480	05381-20005

See paragraph 3-41 for ordering information

Table 3-4. Replaceable Parts

Mfr No.	Manufacturer Name	Address	Zip Code
0086S	STETTNER-TRUSH INC	CAZENOVIA, NY	13035
01121	ALLEN-BRADLEY CO	MILWAUKEE, WI	53212
01295	TEXAS INSTR INC SEMICOND CMPNT DIV	DALLAS, TX	75231
04713	MOTOROLA SEMICONDUCTOR PRODUCTS	PHOENIX, AZ	85008
07263	FAIRCHILD SEMICONDUCTOR DIV	MOUNTAIN VIEW, CA	94040
24226	GOWANDA ELECTRONICS CORP	GOWANDA, NY	14070
24546	CORNING GLASS WORKS (BRADFORD)	BRADFORD, PA	16701
24931	SPECIALTY CONNECTOR CO INC	INDIANAPOLIS, IN	46227
28480	HEWLETT-PACKARD CO CORPORATE HQ	PALO ALTO, CA	94304
32997	BOURNS INC TRIMPOT PROD DIV	RIVERSIDE, CA	92507
56289	SPRAGUE ELECTRIC CO	NORTH ADAMS, MA	01247
72136	ELECTRO MOTIVE MFG CO INC	WILLIMANTIC, CT	06226
75915	LITTLEFUSE INC	DES PLAINES, IL	60016
78452	EVERLOCK CHICAGO INC	CHICAGO, IL	60622
78553	TINNERMAN PRODUCTS INC	CLEVELAND, OH	44129
82389	SWITCHCRAFT INC	CHICAGO, IL	60630

Table 3-5. A1 Replaceable Parts, Option 001

Reference Designation	HP Part Number	Qty	Description	Mfr Code	Mfr Part Number
A1	05381-0007	1	BOARD ASSEMBLY, MAIN (OPTION 001) SERIES 1824A	28480	05381-0007
A1C1	0180-0480	1	CAPACITOR-FXD 4500UF+75-10E 25VDC AL NOT ASSIGNED	56289	340X4526025A2A
A1C2			NOT ASSIGNED		
A1C3	0160-2055	13	CAPACITOR-FXD .01UF +80-20E 100MVDC CER NOT ASSIGNED	28480	0160-2055
A1C4					
A1C5					
A1C6	0180-0061	1	CAPACITOR-FXD 100UF+75-10E 16VDC AL	56289	30010760160C2
A1C7	0180-0094	1	CAPACITOR-FXD 100UF+75-10E 25VDC AL NOT ASSIGNED	56289	3001076025002
A1C8					
A1C9	0160-2055		CAPACITOR-FXD .01UF +80-20E 100MVDC CER	28480	0160-2055
A1C10	0160-2055		CAPACITOR-FXD .01UF +80-20E 100MVDC CER	28480	0160-2055
A1C11	0180-0291	2	CAPACITOR-FXD 1UF+10E 35VDC TA	56289	1500105X9035A2
A1C12	0160-2055		CAPACITOR-FXD .01UF +80-20E 100MVDC CER	28480	0160-2055
A1C13	0160-2055		CAPACITOR-FXD .01UF +80-20E 100MVDC CER	28480	0160-2055
A1C14	0160-2055		CAPACITOR-FXD .01UF +80-20E 100MVDC CER	28480	0160-2055
A1C15	0180-0106	4	CAPACITOR-FXD 60UF+20E 6VDC TA	56289	1500606X0006A2
A1C16	0160-2055		CAPACITOR-FXD .01UF +80-20E 100MVDC CER	28480	0160-2055
A1C17	0160-2055		CAPACITOR-FXD .01UF +80-20E 100MVDC CER	28480	0160-2055
A1C18	0160-2055		CAPACITOR-FXD .01UF +80-20E 100MVDC CER	28480	0160-2055
A1C19	0180-0106		CAPACITOR-FXD 60UF+20E 6VDC TA	56289	1500606X0006A2
A1C20	0160-2055		CAPACITOR-FXD .01UF +80-20E 100MVDC CER	28480	0160-2055
A1C21	0180-0291		CAPACITOR-FXD 1UF+10E 35VDC TA	56289	1500105X9035A2
A1C22	0180-0106		CAPACITOR-FXD 60UF+20E 6VDC TA	56289	1500606X0006A2
A1C23	0180-0106		CAPACITOR-FXD 60UF+20E 6VDC TA	56289	1500606X0006A2
A1C24	0150-0072	1	CAPACITOR-FXD 200PF +-5E 160MVDC CER	28480	0150-0072
A1C25	0140-0204	1	CAPACITOR-FXD 47PF +-5E 500MVDC NICA	72134	0W15E470J0500N1CA
A1C26	0160-2055		CAPACITOR-FXD .01UF +80-20E 100MVDC CER	28480	0160-2055
A1C27	0160-2055		CAPACITOR-FXD .01UF +80-20E 100MVDC CER	28480	0160-2055
A1C28	0160-2055		CAPACITOR-FXD .01UF +80-20E 100MVDC CER	28480	0160-2055
A1C29	0180-1701	1	CAPACITOR-FXD 6.8UF+20E 6VDC TA	56289	1500685X0006A2
A1C30					
A1C31	1908-0028	1	DIODE-MULT FULL WAVE BRIDGE RECTIFIER	04713	W04922-3
A1C32	1901-0040	4	DIODE-SWITCHING 30V 50MA 2N5 DO-35	28480	1901-0040
A1C33	1901-0040		DIODE-SWITCHING 30V 50MA 2N5 DO-35	28480	1901-0040
A1C34	1901-0040	1	DIODE-PRM RECT 400V 750MA DO-29	04713	5R1358-9
A1C35	1902-0579	1	DIODE-ZNR 5.11V 5E DO-15 PD=1W TC=-.009E	28480	1902-0579
A1C36			NOT ASSIGNED		
A1C37	1902-0555	1	DIODE-ZNR 13V 5E DO-15 PD=1W TC=-.008E	28480	1902-0555
A1C38	1901-0040		DIODE-SWITCHING 30V 50MA 2N5 DO-35	28480	1901-0040
A1C39	1901-0040		DIODE-SWITCHING 30V 50MA 2N5 DO-35	28480	1901-0040
A1C40					
A1L1	9100-2251	1	COIL-FXD WADED RF CHOKE .221UH 10E	24226	10/220
A1L2	9140-0137	1	COIL-WLD 1UH 5E U=60 .190X.44LG SRF=39MHZ	24226	19/104
A1M1	1853-0015	3	TRANSISTOR PNP SI PD=200MW FT=500MHZ	28480	1853-0015
A1M2	1853-0015		TRANSISTOR PNP SI PD=200MW FT=500MHZ	28480	1853-0015
A1M3	1853-0071	1	TRANSISTOR NPN SI PD=300MW FT=200MHZ	28480	1853-0071
A1M4	1853-0015		TRANSISTOR PNP SI PD=200MW FT=500MHZ	28480	1853-0015
A1M5	1853-0081	1	TRANSISTOR J-FET 2N5245 N-CHAN D-MODE SI	01295	2N5245
A1M6			NOT ASSIGNED		
A1M7	0683-3355	1	RESISTOR 3.3K 5E .25W FC TC=-900/+1100	01121	C83355
A1M8			NOT ASSIGNED		
A1M9	0761-0022	1	RESISTOR 820 5E 1W NO TC=0+-200	24546	FP32-1-T00-820-J
A1M10	0761-0042	1	RESISTOR 88 5E 1W NO TC=0+-200	24546	FP32-1-T00-880-J
A1M11					
A1M12	0683-3315	1	RESISTOR 330 5E .5W CC TC=0+529	01121	E83315
A1M13	0683-1215	2	RESISTOR 120 5E .25W FC TC=-400/+400	01121	C81215
A1M14	0683-1215	1	RESISTOR 5.1K 5E .25W FC TC=-400/+700	01121	C85125
A1M15	0683-1215	1	RESISTOR 120 5E .25W FC TC=-400/+400	01121	C81215
A1M16	0683-1215	1	RESISTOR 1.5K 5E .25W FC TC=-400/+700	01121	C81525
A1M17					
A1M18	0683-2225	1	RESISTOR 2.2K 5E .25W FC TC=-400/+700	01121	C82225
A1M19	0683-7605	1	RESISTOR 75 5E .25W FC TC=-400/+600	01121	C87605
A1M20	0683-2205	1	RESISTOR 22 5E .25W FC TC=-400/+500	01121	C82205
A1M21	0683-5115	3	RESISTOR 510 5E .25W FC TC=-400/+600	01121	C85115
A1M22	0683-2015	1	RESISTOR 200 5E .25W FC TC=-400/+600	01121	C82015
A1M23					
A1M24	0683-3315	3	RESISTOR 330 5E .25W FC TC=-400/+400	01121	C83315
A1M25	0683-3315		RESISTOR 330 5E .25W FC TC=-400/+400	01121	C83315
A1M26	0683-3315		RESISTOR 330 5E .25W FC TC=-400/+400	01121	C83315
A1M27	2100-0210	1	RESISTOR-TRIM 10K 10E C TYP-ADJ I-TRN	32997	3384P-Y44-103
A1M28	0683-1045	1	RESISTOR 100K 5E .25W FC TC=-400/+800	01121	C81045
A1M29					
A1M30	0683-2025	4	RESISTOR 2K 5E .25W FC TC=-400/+700	01121	C82025
A1M31	0683-2025		RESISTOR 2K 5E .25W FC TC=-400/+700	01121	C82025
A1M32	1810-0125	1	NETWORK-RES 8-PIN-SIP .125-PIN-3PCG	56289	200C-1858-CRR
A1M33	0683-5105	1	RESISTOR 51 5E .5W CC TC=0+412	01121	E85105
A1M34	0683-3345	1	RESISTOR 330K 5E .25W FC TC=-800/+900	01121	C83345

See paragraph 3-41 for ordering information

Table 3-5. A1 Replaceable Parts, Option 001 (Continued)

Reference Designation	HP Part Number	Qty	Description	Mfr Code	Mfr Part Number
A1R20	0683-5115		RESISTOR 510 5% .25W PC TC=400/+600	01121	CB5115
A1R27	0683-0115		RESISTOR 510 5% .25W PC TC=400/+600	01121	CB5115
A1R28	0683-0325	1	RESISTOR 3.3K 5% .25W PC TC=400/+700	01121	CB3325
A1R29	0683-0225		RESISTOR 2K 5% .25W PC TC=400/+700	01121	CB2025
A1R30	0683-0725	1	RESISTOR 7.7M 5% .25W PC TC=400/+700	01121	CB4725
A1R31	0683-2025		RESISTOR 2K 5% .25W PC TC=400/+700	01121	CB2025
A1S1	3101-1977	1	SWITCH-SL DPDT-NS SUMMR .5A 125VAC/DC NOT ASSIGNED	28480	3101-1618
A1S2					
A1S3	3101-0680	1	SWITCH-PR DPDT ALTRG 4A 250VAC	28480	3101-0680
A1U1	1820-1180	1	IC, DIGITAL	28480	1820-1180
A1U2	1820-0174	1	IC-DIGITAL SN7404M TTL HEX 1	01295	SN7404M
A1U3	1820-0693	1	IC-DIGITAL SN74574M TTL 5 DUAL	01295	SN74574M
A1U4	1820-0661	1	IC-DIGITAL SN7432M TTL QUAD 2 DR	01295	SN7432M
A1U5	1820-0328	1	IC-DIGITAL SN7402M TTL QUAD 2 NOR	01295	SN7402M
A1U6	1820-0629	2	IC-DIGITAL SN745112M TTL 5 DUAL J-K	01295	SN745112M
A1U7	1820-0681	1	IC-DIGITAL SN74500M TTL 5 QUAD 2 NAND	01295	SN74500M
A1U8	1820-0099	1	IC-DIGITAL SN7493M TTL 5IN ASYNCRD	01295	SN7493M
A1U9	1820-0634	1	IC-DIGITAL MOS DECD	28480	1820-0634
A1U10	1820-0629	1	IC-DIGITAL SN745112M TTL 5 DUAL J-K	01295	SN745112M
A1U11	1820-0491	1	IC-DIGITAL SN74145M TTL 4 BCD-TO-DEC	01295	SN74145M
A1U12	1820-0269	1	IC-DIGITAL SN7403M TTL QUAD 2 NAND	01295	SN7403M
A1U13	1820-0301	1	IC-DIGITAL SN7475M TTL D-TYPE	01295	SN7475M
A1U14	1820-1224	1	IC-DIGITAL MC1021AP ECL TPL 2 LINE RCVR	04713	MC1021AP
A1U15	1820-0122	1	IC V REGULATOR	07263	7806UC
A1U16	1820-1104	2	IC-DIGITAL SN74LS02M TTL LS QUAD 2 NOR	01295	SN74LS02M
A1U17	1820-1112	1	IC-DIGITAL SN74LS74M TTL LS DUAL	01295	SN74LS74M
A1U18	1820-1251	1	IC-DIGITAL SN74LS194M TTL LS DECD	01295	SN74LS194M
A1U19	0960-0194	1	CRYSTAL OSCILLATOR 10 MHZ	28480	0960-0194
A1R01	1200-0473	1	SOCKET-IC 16-CONT DIP-SLDA	28480	1200-0473

See paragraph 3-41 for ordering information

# **SCHEMATIC DIAGRAMS**

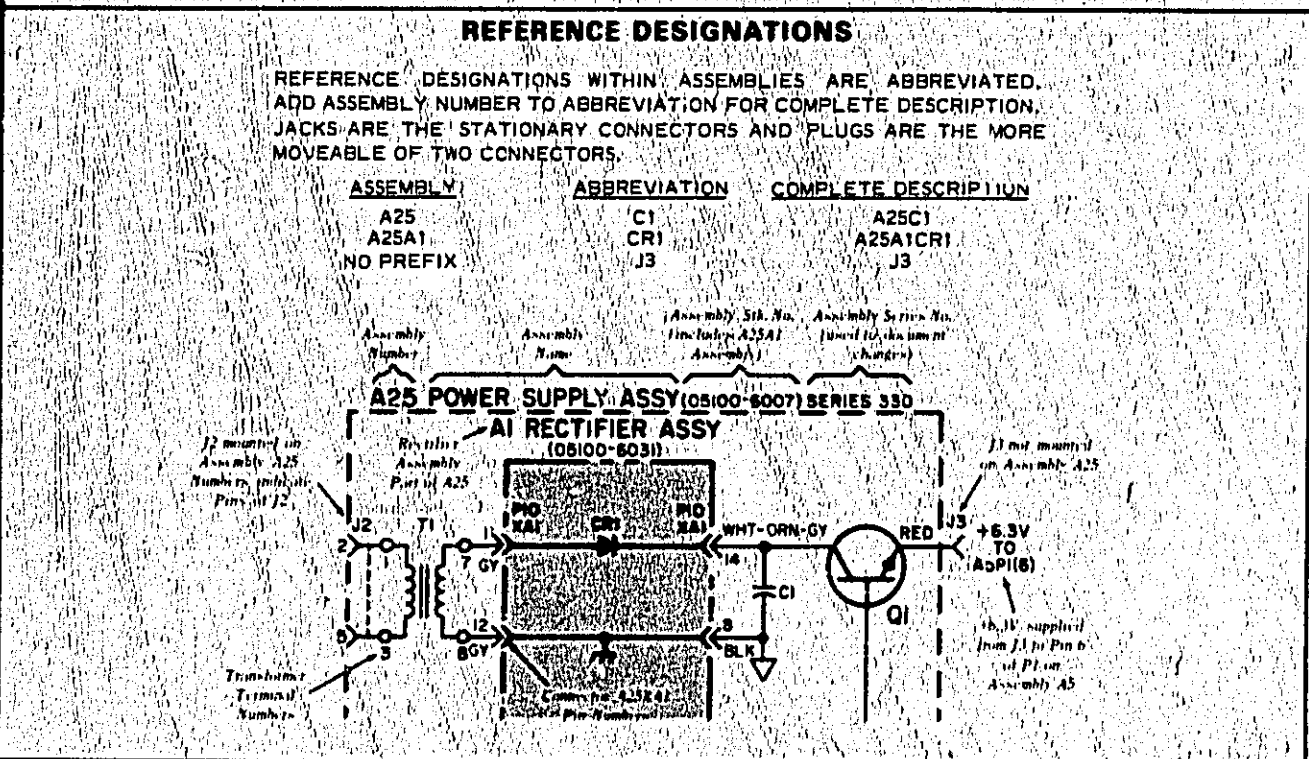
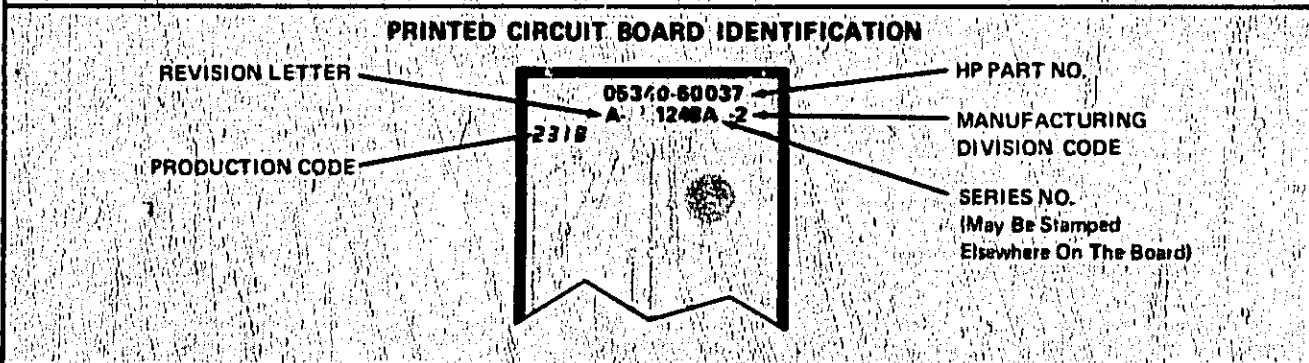
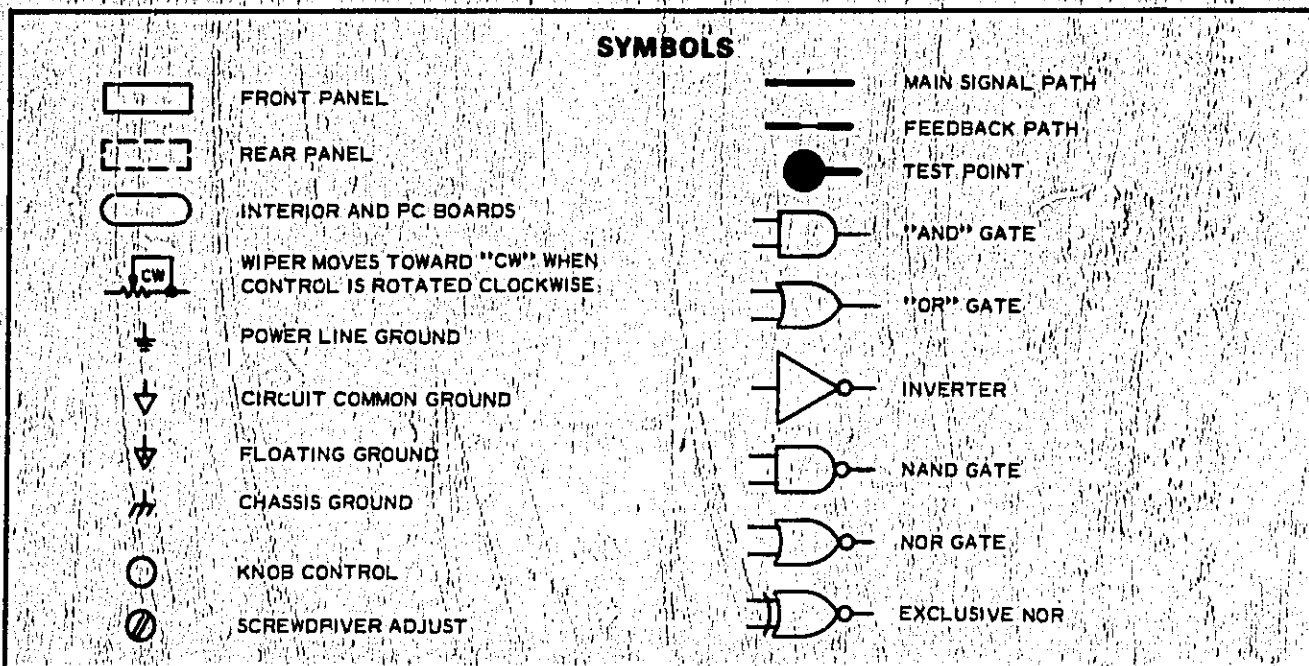
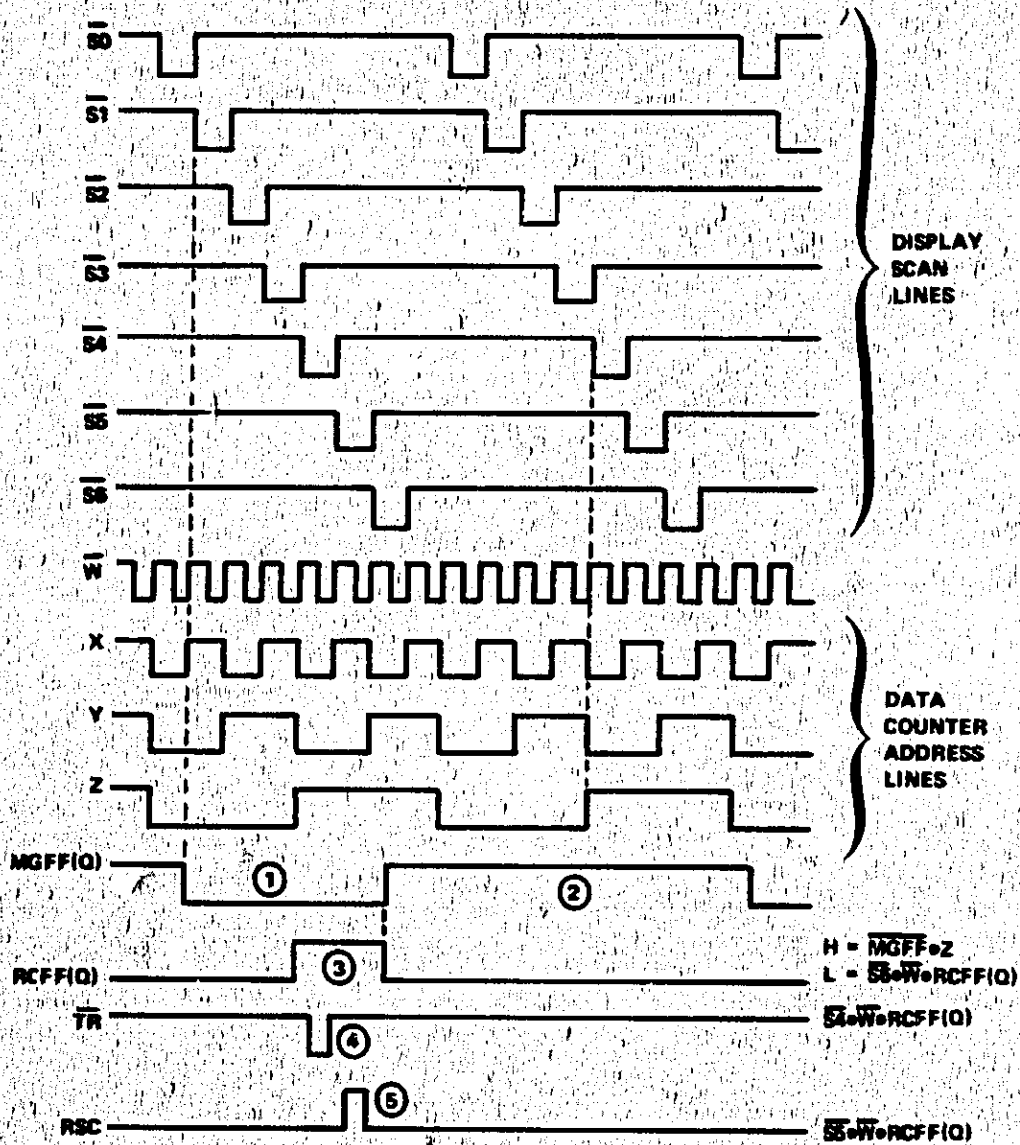

Figure 3-3. Schematic Diagram Notes



- ① MAIN GATE CLOSED.
- ② MAIN GATE OPEN.
- ③ WHEN HIGH, TIME BASE DIVIDER PRESET TO ALL NINES. THIS ALLOWS A TIME BASE OUTPUT AND OPENING OF MAIN GATE ON FIRST OSCILLATOR CYCLE AFTER SIGNAL GOES LOW.
- ④ TRANSFERS DATA TO STORAGE LATCHES.
- ⑤ REBETS DATA COUNTER.

5301-A-6

Figure 3-4. Instrument Timing Diagram

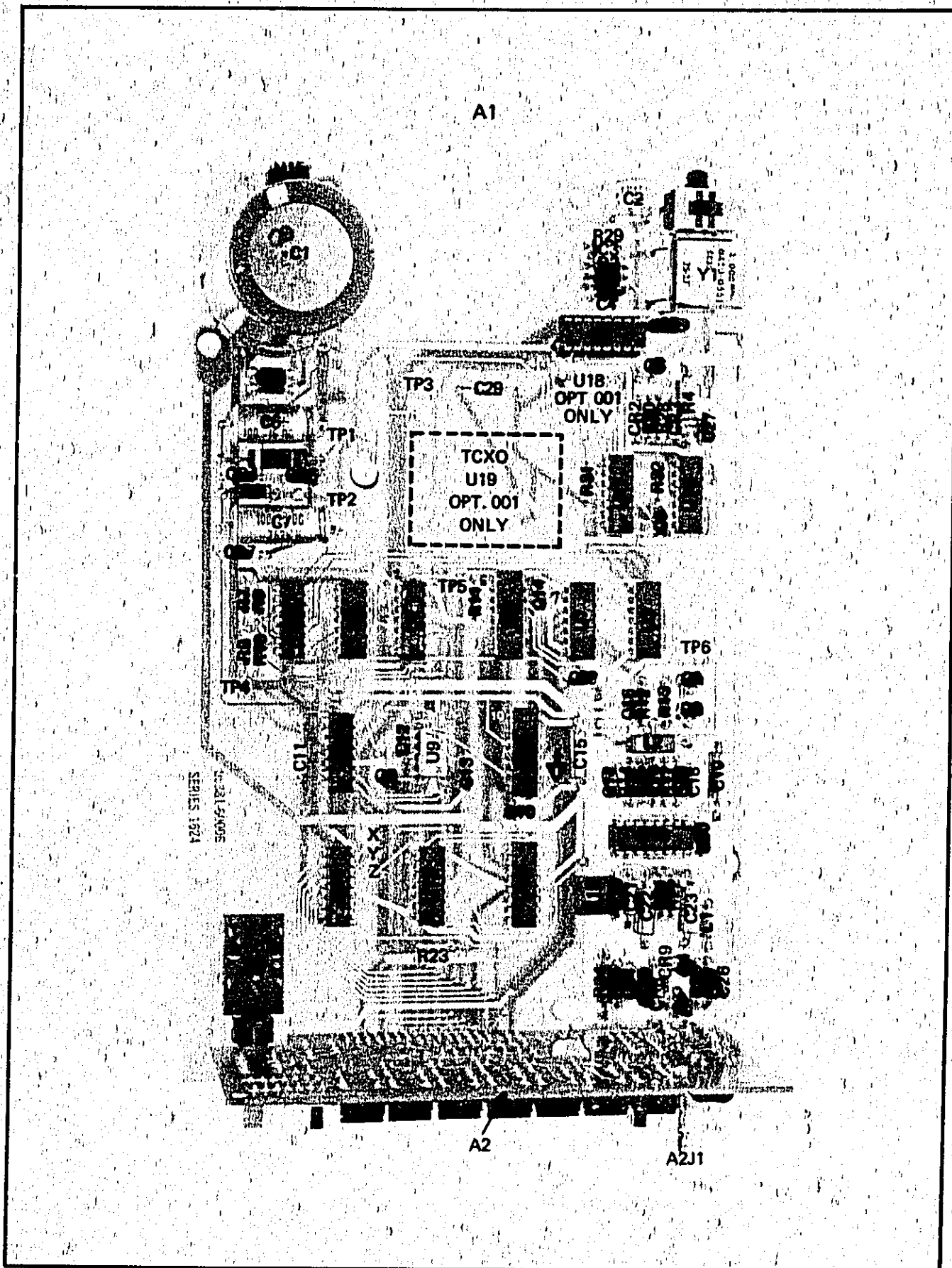

Figure 3-5. A1 (05381-60006) Series 1624 Component Locator

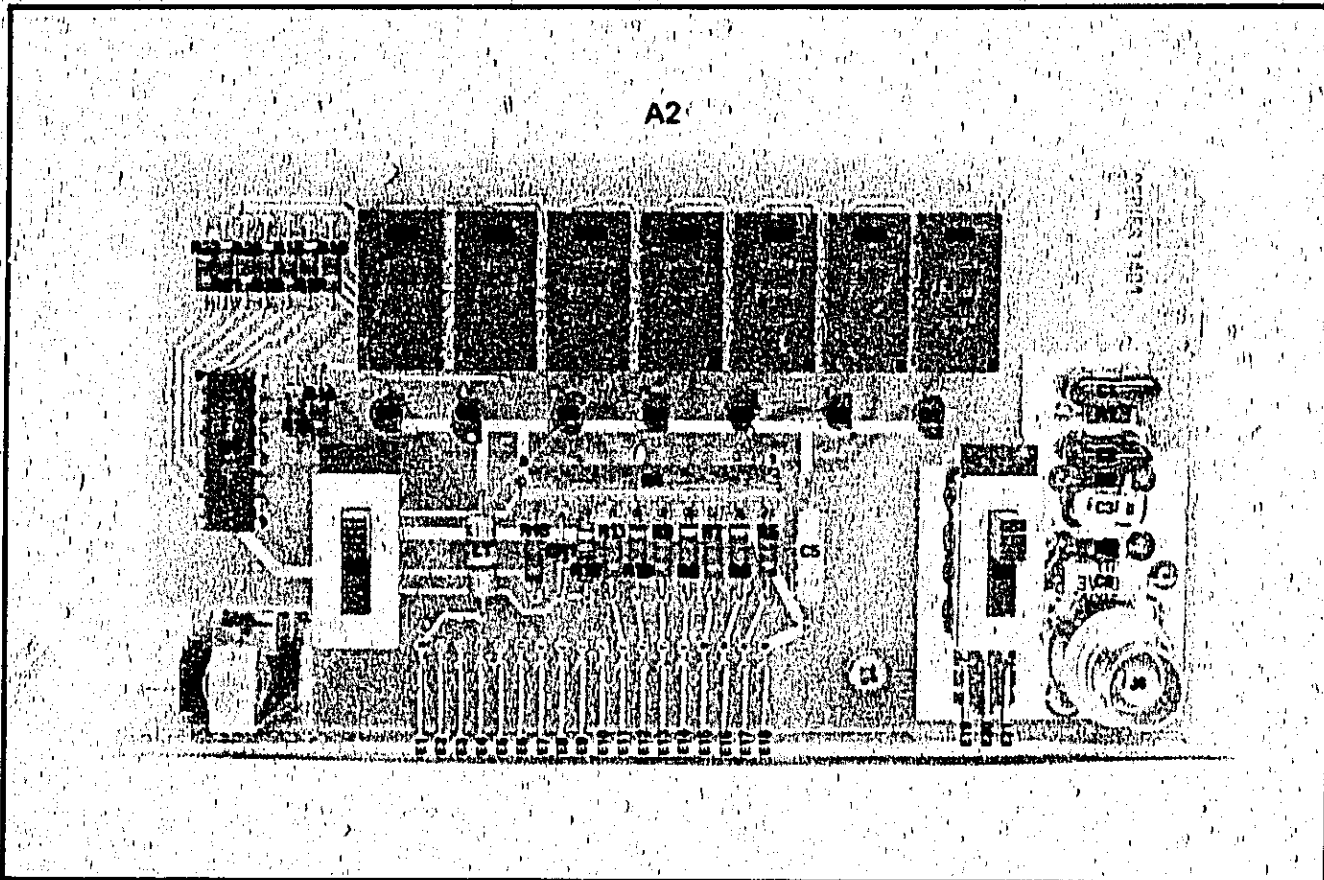

Figure 3-6. A2 Component Locator

NOTES

1. REFERENCE DESIGNATIONS WITHIN THIS ASSEMBLY ARE ABBREVIATED. ADD ASSEMBLY NUMBER TO ABBREVIATION FOR COMPLETE DESCRIPTION.
2. UNLESS OTHERWISE INDICATED:  
RESISTANCE IN OHMS;  
CAPACITANCE IN PICOFARADS;  
INDUCTANCE IN MICROHENRIES
3. ASTERISK (\*) INDICATES SELECTED COMPONENT. AVERAGE VALUES SHOWN.
4. DISPLAY A2DS7 IS PHYSICALLY MOUNTED UPSIDE DOWN TO ALLOW ONE OF THE DECIMAL POINTS TO BE USED AS AN OVER RANGE INDICATOR.
5. SEE A2 COMPONENT LOCATOR FOR E TERMINAL LOCATIONS.

ACTIVE ELEMENTS

REFERENCE DESIGNATIONS	HP PART NUMBERS
A1	
CR1, 4	1006-0028
CR2, 3, B, D	1001-0040
CR5	1802-0570
CR6	NOT ASSIGNED
CR7	1802-0555
Q1, 2, 4	1853-0015
Q3	1854-0071
Q5, 6	1855-0081
U1	1820-1180
U2	1820-0174
U3	1820-0693
U4	1820-0661
U5	1820-0328
U6, 10	1820-0629
U7	1820-0681
U8	1820-0099
U9	1820-0634
U11	1820-0491
U12	1820-0269
U13	1820-0301
U14	1820-1224
U15	1826-0122
U16	1820-1144
U17	1820-1112
* U18	1820-1251
* U19	0960-0394
A2	
CR1	1001-0040
Q1,7	1953-0318
U1	1820-1037
CR1	1001-0040
Q1,7	1953-0318
U1	1820-1037

\* OPTION 001 ONLY



**BACK DATING  
MANUAL  
CHANGES**

## SECTION IV MANUAL CHANGES

### 4-1. INTRODUCTION

4-2. This section contains information necessary to adapt this manual to older instruments.

### 4-3. MANUAL CHANGES

4-4. This manual applies directly to Model 5381A Frequency Counters with serial prefix 1624A. See paragraph 1-5 for details of serial number identification.

### 4-5. Newer Instruments

4-6. As changes are made, newer instruments may have serial prefixes that are not listed in this manual. The manual for these instruments are supplied with a manual change sheet which contains the required updating information. If this sheet is missing, contact the nearest Hewlett-Packard Sales and Service Office listed at the back of this manual.

### 4-7. Older Instruments

4-8. To adapt this manual to instruments having a serial prefix prior to that listed on the title page, perform the backdating that applies to your instrument's serial prefix or serial number as listed in the table below:

#### NOTE

Start at the change with the highest number and perform changes in a descending sequence.

Table 4-1. Manual Backdating

Instrument Serial Prefix or Serial Number		Make following changes to backdate this manual
From	Thru	
1404A	1404A1700	1, 2, 3, 4, 5, 6
1404A1701	1404A02235	2, 3, 4, 5, 6
1404A02236	1404A02485	3, 4, 5, 6
1520A02486	1520A02735	4, 5, 6
1520A02736	1532A03485	5, 6
1532A03486	1548A04985	6
1624A04986 and above		None

### CHANGE 1

Table 4-2, A1 (05381-60001) Replaceable Parts:

Change A1R4 from 0686-3925 (3900Ω) to 0686-7525; RESISTOR-FXD 7500 OHM 5% .5W CC TUBULAR; 01121; EB7525.

Change A1R21 and A1R22 from 0683-2025 (2000Ω) to 0683-1025 RESISTOR-FXD 1000 OHM 5% .25W CC TUBULAR; 01121; CB1025.

NOTE — Some instruments with serial number 1407A01700 and below have 2000 ohm resistors for A1R21 and A1R22.

**Model 5381A  
Manual Changes**

**Figure 4-1, A1 (05381-60001) Schematic Diagram:  
Change A1R4 from 3900 to 7500 ohms.**

**Change A1R21 and A1R22 from 2000 to 1000 ohms, see above note.**

**CHANGE 2**

**Table 4-2, A1 (05381-60001) Replaceable Parts:**

**Change A1R17 and A1R18 from 0683-3315 (330Ω) to 0683-5115; RESISTOR-FXD 510 OHM 5% 5% .25W CC TUBULAR; 01121; CB5115.**

**Figure 4-1, A1 (05381-60001) Schematic Diagram:**

**Change A1R17 and A1R18 from 330 to 510 ohms.**

**CHANGE 3**

**Page 3-13, Table 3-3, A1 (05381-60006) Replaceable Parts, Standard Instrument:**

**Replace parts list for A1 with parts list in Table 4-2 for part number 05381-60001 SERIES 1404 circuit board.**

**Change rear panel (under CHASSIS AND MISCELLANEOUS PARTS) from Part No. 05382-00002 to 05381-00001 in "HP" and "MFR" columns of Table 3-3.**

**The 05381-60001 circuit board in instruments with serial prefix 1404A is not directly interchangeable with the 05381-60006 or 5381-60007 (Option 001) circuit boards.**

**Page 3-21, Figure 3-5, Component Locator and Page 3-23, Figure 3-7 Schematic Diagram:**

**Replace A1 schematic diagram and component locator with Figure 4-1 Schematic Diagram/Component Locator for A1 SERIES 1404 circuit board.**

**CHANGE 4**

**Page 2-2, Paragraph 2-9, step b:**

**Change to the following: "Ensure that the correct fuse is installed. Use a Listed 0.250 ampere, slow-blow fuse for 100-volt or 120-volt operation or a Listed 0.125 ampere, slow-blow fuse for 220-volt or 240-volt operation."**

**Page 2-4, Figure 2-4, Rear View:**

**Change 48-440 ~ 30 VA MAX to 48-440 ~ 15 VA MAX.**

**Change fuse label to the following:**

**250 MaT 100/120V**

**125 MaT 220/240V**

**Change item 2 fuse value to .250 ampere and 0.125 ampere.**

**Page 3-15, Table 3-3, Chassis and Misc. Parts:**

**Change F1 from 2110-0008 to 2110-0018 1/4A (100/120V Operation).**

**Change the other F1 from 2110-0201 to 2110-0318 0.125 amp (220/240V Operation).**

**NOTE — The 2110-0008 (500 mA T for 100/120V operation) and the 2110-0201 (250 mA T for 220/240V operation) fuses listed in Table 3-3 are recommended for replacement in all 5381A counters.**

**CHANGE 5**

**Table 4-3, A1 (05381-60006) SERIES 1548 Replaceable Parts:**

**Change A1 from SERIES 1548 to SERIES 1520.**

**Add A1CR6 1901-0040 Diode: Switching 30V Max VRM 50 mA, 28480, 1901-0040.**

Change A1CR7 to 1902-0555, Diode: Zener, 13V VZ, 1W Max PD, 04713, SZ 11213-173.

Figure 4-2, A1 (05381-60006) SERIES 1548 Schematic Diagram:

Change SERIES 1548, at top of diagram and in caption, to SERIES 1520.

Add A1CR6 between TP2 and A1R6 with anode to TP2 and cathode to A1R6. Delete the straight through or direct connection between these two points.

Change voltage to A1U9(5) to "-14V" at end of line from A1R6 and at A1U9 pin 5.

Change voltage to A1U1(16) to "-13V" at end of line from A1CR7 and at A1U1 pin 16.

Change voltage beside A1CR7 from "-15V" to "-13V".

#### CHANGE 6

Instruments with a Serial Prefix of 1548 or below do not have provisions for adding Option 001. Any reference to Option 001 should be deleted. Rear panel BNC jack J2 can only be used as an input connector for an external time base or for ratio measurements. A time base monitor output signal is not available from J2.

Page 3-13, Table 3-3, A1 (05381-60006) Replaceable Parts, Standard-Instrument:

Replace parts list in Table 3-3 for A1 with parts list in Table 4-3.

Delete Part No. 05382-00003 (Option 001) rear panel from listing under Chassis and Miscellaneous Parts.

Page 3-12, Table 3-3, A2 (05381-60002) Replaceable Parts:

Change A2 from SERIES 1624 to SERIES 1404.

Change A2R4 from 1810-0076 (1800 $\Omega$ /section) to 1810-0041; NETWORK-RES 9-PIN SIP 2700 $\Omega$ /SECTION; 28480; 1810-0041.

Page 3-17, Table 3-5, A1 (05381-60007) Replaceable Parts, Option 001:

Delete Table 3-5 for A1 part number 05381-60007 circuit board with Option 001 temperature compensated crystal oscillator (TCXO).

Page 3-21, Figure 3-5, A1 Component Locator and Page 3-23, Figure 3-7, A1 schematic diagram:

Replace A1 schematic diagram and component locator with Figure 4-2 Schematic Diagram/Component Locator for A1 Series 1548 circuit board.

Page 3-21, Figure 3-7, Overall Schematic Diagram:

Change SERIES 1624, at top of A2 schematic, to SERIES 1404.

Change A2R4 value from 1800 $\Omega$  to 2700 $\Omega$  per section.

NOTE — The 1800 resistor pack (1810-0076) for A2R4 along with the 1820-0491 BCD to decimal decoder for A1U11 on the 5381-60006 Series 1624 circuit board are recommended replacements (as a pair) for all instruments with Serial Prefix 1548A and below.

Model 5381A  
Maintenance

Table 4-2. Replaceable Parts, A1 Series 1404

Reference Designation	HP Part Number	Qty	Description	Mfr Code	Mfr Part Number
A1	05381-8001	1	BOARD ASSY, MAIN (SERIES 1404)	28480	05381-8001
A1C1	0180-0480	1	CAPACITOR-FXD; 4500*75-10%; 25VDC AL	56289	380X452G025AA2A
A1C2	0121-0105	1	CAPACITOR, VAR, YMR, CER, 9/35PF	73899	DV11PR35D
A1C3	0140-0175	2	CAPACITOR-FXD 39PF+-2% 300MVDC	72134	DM15E390G0300MV1CR
A1C4	0150-0075	7	CAPACITOR-FXD .0047UF+100-20% 500MVDC	28480	0150-0075
A1C5	0140-0175	1	CAPACITOR-FXD 39PF+-2% 300MVDC	72134	DM15E390G0300MV1CR
A1C6	0180-0061	1	CAPACITOR-FXD; 100UF+75-10% 16VDC AL	56289	300107G016DC2
A1C7	0180-0058	1	CAPACITOR-FXD; 50UF+75-10% 25VDC AL	56289	300506G025CC2
A1C8	0150-0075	1	CAPACITOR-FXD .0047UF+100-20% 500MVDC	28480	0150-0075
A1C9	0150-0075	1	CAPACITOR-FXD .0047UF+100-20% 500MVDC	28480	0150-0075
A1C10	0150-0075	1	CAPACITOR-FXD .0047UF+100-20% 500MVDC	28480	0150-0075
A1C11	0180-0261	2	CAPACITOR-FXD; 1UF+-10% 35VDC TA-SOLID	56289	1500106X9036A2
A1C12	0150-0075	1	CAPACITOR-FXD .0047UF+100-20% 500MVDC	28480	0150-0075
A1C13	0150-0075	1	CAPACITOR-FXD .0047UF+100-20% 500MVDC	28480	0150-0075
A1C14	0150-0075	1	CAPACITOR-FXD .0047UF+100-20% 500MVDC	28480	0150-0075
A1C15	0180-0106	1	CAPACITOR-FXD; 80UF+-20% 6VDC TA-SOLID	56289	1500806X0006B2
A1C16	0150-0122	5	CAPACITOR-FXD .002UF+-20% 500MVDC	28480	0150-0122
A1C17	0150-0122	1	CAPACITOR-FXD .002UF+-20% 500MVDC	28480	0150-0122
A1C18	0150-0122	1	CAPACITOR-FXD .002UF+-20% 500MVDC	28480	0150-0122
A1C19	0180-0106	1	CAPACITOR-FXD; 80UF+-20% 6VDC TA-SOLID	56289	1500806X0006B2
A1C20	0150-0122	1	CAPACITOR-FXD .002UF+-20% 500MVDC	28480	0150-0122
A1C21	0180-0291	1	CAPACITOR-FXD; 1UF+-10% 35VDC TA-SOLID	56289	1500109X9035A2
A1C22	0180-0106	1	CAPACITOR-FXD; 80UF+-20% 6VDC TA-SOLID	56289	1500806X0006B2
A1C23	0180-0106	1	CAPACITOR-FXD; 80UF+-20% 6VDC TA-SOLID	56289	1500806X0006B2
A1C24	0150-0072	1	CAPACITOR-FXD 200PF+-5% 1000VDC	28480	0150-0072
A1C25	0140-0204	1	CAPACITOR-FXD 47PF+-5% 500MVDC	72134	DM15E470J0500MV1CR
A1C26	0150-0122	1	CAPACITOR-FXD .002UF+-20% 500MVDC	28480	0150-0122
A1CR1	1906-0028	1	DIODE, MULT, FULL WAVE BRIDGE RECTIFIER	04713	MDA922-3
A1CR2	1901-0040	6	DIODE; SWITCHING; 1: 30V MAX VRM 50MA	28480	1901-0040
A1CR3	1901-0040	1	DIODE; SWITCHING; 1: 30V MAX VRM 50MA	28480	1901-0040
A1CR4	1901-0028	1	DIODE; PWR RECT; 1: 400V MAX VRM 750MA	04713	SR135B-9
A1CR5	1902-0579	1	DIODE; ZENER; 5.11V VZ; 1W MAX PD	04713	SZ 11213-56
A1CR6	1901-0040	1	DIODE; SWITCHING; 1: 30V MAX VRM 50MA	28480	1901-0040
A1CR7	1902-0555	1	DIODE; ZENER; 13V VZ; 1W MAX PD	04713	SZ 11213-173
A1CR8	1901-0040	1	DIODE; SWITCHING; 1: 30V MAX VRM 50MA	28480	1901-0040
A1CR9	1901-0040	1	DIODE; SWITCHING; 1: 30V MAX VRM 50MA	28480	1901-0040
A1L1	9180-2251	1	COIL, FXD, MOLDED RF CHOKE; .22UH 10% COIL; FXD; MOLDED RF CHOKE; 1RM 5% TRANSISTOR PNP SI CHIP PD=200MH TRANSISTOR PNP SI CHIP PD=200MH TRANSISTOR NPN SI PD=300MH FT=200MHZ	24226 24226 28480 28480 28480	107220 197104 1853-0015 1853-0015 1854-0071
A1L2	9140-0137	1	COIL, FXD, MOLDED RF CHOKE; .22UH 10%	24226	107220
A1Q1	1853-0015	3	TRANSISTOR PNP SI CHIP PD=200MH	28480	1853-0015
A1Q2	1853-0015	1	TRANSISTOR PNP SI CHIP PD=200MH	28480	1853-0015
A1Q3	1854-0071	1	TRANSISTOR NPN SI PD=300MH FT=200MHZ	28480	1854-0071
A1Q4	1853-0015	1	TRANSISTOR PNP SI CHIP PD=200MH	28480	1853-0015
A1Q5	1853-0081	1	TRANSISTOR; J-FET N-CAN, D-MODE SI	01295	ZM245
A1R1	0683-2435	1	RESISTOR-FXD 24K 5% .25W CC TUBULAR	01121	CB2435
A1R2	0683-2255	1	RESISTOR-FXD 1.2K 5% .25W CC TUBULAR	01121	CB1255
A1R3	0683-2055	1	RESISTOR-FXD 24 5% .25W CC TUBULAR	01121	CB2055
A1R4	0683-3025	1	RESISTOR-FXD 300 5% 1/2W MO TUBULAR	01121	EB3025
A1R5	0761-0042	1	RESISTOR-FXD 68 OHM 5% 1W MO TUBULAR	24544	FP32-1-T00-68R0-J
A1R6	0761-0026	1	RESISTOR-FXD 220 OHM 5% 1W MO TUBULAR	24544	FP32-1-T00-221-J
A1R7	0683-1215	2	RESISTOR-FXD 120 OHM 5% .25W CC TUBULAR	01121	CB1215
A1R8	0683-5125	1	RESISTOR-FXD 5.1K 5% .25W CC TUBULAR	01121	CB5125
A1R9	0683-1215	1	RESISTOR-FXD 120 OHM 5% .25W CC TUBULAR	01121	CB1215
A1R10	0683-1525	1	RESISTOR-FXD 1.5K 5% .25W CC TUBULAR	01121	CB1525
A1R11	0683-2225	1	RESISTOR-FXD 2.2K 5% .25W CC TUBULAR	01121	CB2225
A1R12	0683-5605	1	RESISTOR-FXD 56 OHM 5% .25W CC TUBULAR	01121	CB5605
A1R13	0683-2205	1	RESISTOR-FXD 22 OHM 5% .25W CC TUBULAR	01121	CB2205
A1R14	0683-5115	5	RESISTOR-FXD 510 OHM 5% .25W CC TUBULAR	01121	CB5115
A1R15	0683-2015	1	RESISTOR-FXD 200 OHM 5% .25W CC TUBULAR	01121	CB2015
A1R16	0683-3315	1	RESISTOR-FXD 330 OHM 5% .25W CC TUBULAR	01121	CB3315
A1R17	0683-3315	1	RESISTOR-FXD 330 OHM 5% .25W CC TUBULAR	01121	CB3315
A1R18	0683-3315	1	RESISTOR-FXD 330 OHM 5% .25W CC TUBULAR	01121	CB3315
A1R19	2100-3210	1	RESISTOR,VAR,YMR 10K OHM 10% C	32997	3389P-1-103
A1R20	0683-1045	1	RESISTOR-FXD 100K 5% .25W CC TUBULAR	01121	CB1045
A1R21	0683-2025	2	RESISTOR-FXD 2K 5% .25W CC TUBULAR	01121	CB2025
A1R22	0683-2025	1	RESISTOR-FXD 2K 5% .25W CC TUBULAR	01121	CB2025
A1R23	1810-0125	1	CIRCUIT, PSIV, NON-REPRABLE IN	28480	1810-0125
A1R24	0683-5105	1	RESISTOR-FXD 51 OHM 5% .5W CC TUBULAR	01121	EB5105
A1R25	0683-3345	1	RESISTOR-FXD 330K 5% .25W CC TUBULAR	01121	CB3345
A1R26	0683-5115	1	RESISTOR-FXD 510 OHM 5% .25W CC TUBULAR	01121	CB5115
A1R27	0683-5115	1	RESISTOR-FXD 510 OHM 5% .25W CC TUBULAR	01121	CB5115
A1S1	3101-1667	1	SWITCH; SLE SPDT NS; .5A 125VAC	28480	3101-1667
A1S2	3101-0693	1	SWITCH; SLIDE 2-DPDT;NON-SHORTING	82389	A-3101-0693-1
A1S3	3101-0680	1	SWITCH; PB 1-5TA MODULE 4PDT	28480	3101-0680
A1U1	1820-1180	1	IC, DIGITAL	28480	1820-1180
A1U2	1820-0174	1	IC;DGTL;INVERTER	01295	SN7404N

See introduction to this section for ordering information

Table 4-2. Replaceable Parts, A1 Series 1404 (Continued)

Reference Designation	HP Part Number	Qty	Description	Mfr Code	Mfr Part Number
A1U3	1820-0693	1	IC: DGTL; FLIP-FLOP	01295	SN74574N
A1U4	1820-0651	1	IC: DGTL; GATE	01295	SN7432N
A1U5	1820-0328	1	IC: DGTL; GATE	01295	SN7402N
A1U6	1820-0629	2	IC: DGTL; FLIP-FLOP	01295	SN745112N
A1U7	1820-0681	1	IC: DGTL; GATE	01295	SN74500N
A1U8	1820-0099	1	IC: DGTL; COUNTER	01295	SN7493N
A1U9	1820-0634	1	IC: M.O.S., 8-DECADE COUNTER	28480	1820-0634
A1U10	1820-0629	1	IC: DGTL; FLIP-FLOP	01295	SN745112N
A1U11	1820-0214	1	IC: DGTL; DECODER/DECODER DR VR/DATA DISTR	01295	SN7442N
A1U12	1820-0269	1	IC: DGTL; GATE	01295	SN7403N
A1U13	1820-0301	1	IC: DGTL; LATCH	01295	SN7475N
A1U14	1820-1224	1	IC: DGTL; LINE RECEIVER	04713	MC10216P
A1U15	1826-0122	1	IC: LIN; VOLTAGE REGULATOR	07263	7805UC
A1Y1	0410-0551	1	CRYSTAL, QUARTZ	28480	0410-0551

See Introduction to this section for ordering information.

Table 4-3. Replaceable Parts, A1 Series 1548

Reference Designation	HP Part Number	Qty	Description	Mfr Code	Mfr Part Number
A1	05181-60006	1	BOARD ASSEMBLY, MAIN (SERIES 1548)	28480	05181-60006
A1C1	0160-0480	1	CAPACITOR, FXD 450UF +75-10% 25VDC AL	56289	360K452G023AA2A
A1C2	0121-0195	1	CAPACITOR-V TRM-CER 9/35PF 200V PC-NTC	00065	304324 9/35PF N650
A1C3	0160-2265	1	CAPACITOR-FXD 22PF +-5% 500VDC CER	28480	0160-2265
A1C4	0160-2055	1	CAPACITOR-FXD .01UF +80-20% 100VDC CER	28480	0160-2055
A1C5	0160-0192	1	CAPACITOR-FXD 68PF +-5% 300VDC MICA	72136	DM15E480J0300WV1CR
A1C6	0160-0061	1	CAPACITOR-FXD 100UF+75-10% 16VDC AL	56289	300107G01A0C2
A1C7	0160-0058	1	CAPACITOR-FXD 50UF+75-10% 25VDC AL	56289	300506G025CC2
A1C8	0160-2055	1	CAPACITOR-FXD .01UF +80-20% 100VDC CER	28480	0160-2055
A1C9	0160-2055	1	CAPACITOR-FXD .01UF +80-20% 100VDC CER	28480	0160-2055
A1C10	0160-2055	1	CAPACITOR-FXD .01UF +80-20% 100VDC CER	28480	0160-2055
A1C11	0160-0291	2	CAPACITOR-FXD 1UF+-10% 35VDC TA	56289	1500105X9035A2
A1C12	0160-2055	1	CAPACITOR-FXD .01UF +80-20% 100VDC CER	28480	0160-2055
A1C13	0160-2055	1	CAPACITOR-FXD .01UF +80-20% 100VDC CER	28480	0160-2055
A1C14	0160-2055	1	CAPACITOR-FXD .01UF +80-20% 100VDC CER	28480	0160-2055
A1C15	0160-0106	5	CAPACITOR-FXD 60UF+-20% 6VDC TA	56289	1500606X0006B2
A1C16	0160-2055	1	CAPACITOR-FXD .01UF +80-20% 100VDC CER	28480	0160-2055
A1C17	0160-2055	1	CAPACITOR-FXD .01UF +80-20% 100VDC CER	28480	0160-2055
A1C18	0160-2055	1	CAPACITOR-FXD .01UF +80-20% 100VDC CER	28480	0160-2055
A1C19	0160-2055	1	CAPACITOR-FXD .01UF +80-20% 100VDC CER	28480	0160-2055
A1C19	0160-0106	1	CAPACITOR-FXD 60UF+-20% 6VDC TA	56289	1500606X0006B2
A1C20	0160-2055	1	CAPACITOR-FXD .01UF +80-20% 100VDC CER	28480	0160-2055
A1C21	0160-0291	1	CAPACITOR-FXD 1UF+-10% 35VDC TA	56289	1500105X9035A2
A1C22	0160-0106	1	CAPACITOR-FXD 60UF+-20% 6VDC TA	56289	1500606X0006B2
A1C23	0160-0106	1	CAPACITOR-FXD 60UF+-20% 6VDC TA	56289	1500606X0006B2
A1C24	0150-0072	1	CAPACITOR-FXD 200PF +-5% 1000VDC CER	28480	0150-0072
A1C25	0160-0206	1	CAPACITOR-FXD 47PF +-5% 500VDC MICA	72136	DM15E470J0500WV1CR
A1C26	0160-2055	1	CAPACITOR-FXD .01UF +80-20% 100VDC CER	28480	0160-2055
A1C27	0160-2055	1	CAPACITOR-FXD .01UF +80-20% 100VDC CER	28480	0160-2055
A1C28	0160-0161	1	CAPACITOR-FXD .01UF +-10% 200VDC POLYE	56289	292P10392
A1CR1	1902-0028	1	DIODE-MULTI FULL WAVE BRIDGE RECTIFIER	04713	MDA922-3
A1CR2	1901-0040	5	DIODE-SWITCHING 30V 50MA 2MS DO-35	28480	1901-0040
A1CR3	1901-0040	1	DIODE-SWITCHING 30V 50MA 2MS DO-35	28480	1901-0040
A1CR4	1901-0028	1	DIODE-PWR RECT 400V 750MA DO-29	04713	5R1358-9
A1CR5	1902-0579	1	DIODE-DR 5.11V 5% DO-15 PD=1W TC=-.009E	28480	1902-0579
A1CR6			NOT ASSIGNED		
A1CR7	1902-0202	1	DIODE-DR 15V 5% DO-15 PD=1W TC=-.057E	28480	1902-0202
A1CR8	1901-0040	1	DIODE-SWITCHING 30V 50MA 2MS DO-35	28480	1901-0040
A1CR9	1901-0040	1	DIODE-SWITCHING 30V 50MA 2MS DO-35	28480	1901-0040
A1L1	9100-2291	1	COIL-FXD MOLDED AF CHOKER .22UH 10% 5% 100V	24226	10/220
A1L2	9140-0137	2	COIL-FXD MOLDED AF CHOKER 1MH 5% 100V	24226	19/104
A1Q1	1853-0015	3	TRANSISTOR PNP SI PD=200MW FT=500MHZ	28480	1853-0015
A1Q2	1853-0015	1	TRANSISTOR PNP SI PD=200MW FT=500MHZ	28480	1853-0015
A1Q3	1854-0071	1	TRANSISTOR NPN SI PD=300MW FT=200MHZ	28480	1854-0071
A1Q4	1853-0015	1	TRANSISTOR PNP SI PD=200MW FT=500MHZ	28480	1853-0015
A1Q5	1853-0001	1	TRANSISTOR J-FET 2N5245 N-CHAN D-MODE SI	01295	2N5245
A1R1	0483-2435	1	RESISTOR 24K 5% .25W FC TC=-400/+800	01121	C82435
A1R2	0483-3355	1	RESISTOR 3.3K 5% .25W FC TC=-900/+1100	01121	C83355
A1R3	0483-2435	1	RESISTOR 3.3K 5% .25W FC TC=-900/+1100	01121	C85435
A1R4	0483-2225	2	RESISTOR 2.2K 5% .25W FC TC=-400/+700	01121	C82225
A1R5	0761-0842	1	RESISTOR 68 5% 1W MO TC=0/+200	26546	FP32-1-700-68R0-J
A1R6	0761-0826	1	RESISTOR 220 5% 1W MO TC=0/+200	26546	FP32-1-700-221-J
A1R7	0483-1215	2	RESISTOR 120 5% .25W FC TC=-400/+600	01121	C81215
A1R8	0483-5125	1	RESISTOR 5.1K 5% .25W FC TC=-400/+700	01121	C85125
A1R9	0483-1215	1	RESISTOR 120 5% .25W FC TC=-400/+600	01121	C81215
A1R10	0483-1325	1	RESISTOR 1.3K 5% .25W FC TC=-400/+700	01121	C81325
A1R11	0483-2225	1	RESISTOR 2.2K 5% .25W FC TC=-400/+700	01121	C82225
A1R12	0483-2435	1	RESISTOR 24 5% .25W FC TC=-400/+800	01121	C83435
A1R13	0483-2205	1	RESISTOR 22 5% .25W FC TC=-400/+500	01121	C82205
A1R14	0483-5125	3	RESISTOR 510 5% .25W FC TC=-400/+800	01121	C85115
A1R15	0483-2015	1	RESISTOR 200 5% .25W FC TC=-400/+600	01121	C82015
A1R16	0483-3315	3	RESISTOR 330 5% .25W FC TC=-400/+800	01121	C83315
A1R17	0483-3315	1	RESISTOR 330 5% .25W FC TC=-400/+800	01121	C83315
A1R18	0483-3315	1	RESISTOR 330 5% .25W FC TC=-400/+800	01121	C83315
A1R19	2100-0210	1	RESISTOR-TRM 10K 10% C TOP-ADJ 1-TRM	32977	3284P-Y46-103
A1R20	0483-1045	1	RESISTOR 100K 5% .25W FC TC=-400/+800	01121	C81045
A1R21	0483-2025	2	RESISTOR 2K 5% .25W FC TC=-400/+700	01121	C82025
A1R22	0483-2025	1	RESISTOR 2K 5% .25W FC TC=-400/+700	01121	C82025
A1R23	1810-0825	1	NETWORK-RES 8-PIN-SIP .125-PIN-5PCG	28480	1810-0825
A1R24	0484-5105	1	RESISTOR 51 5% .5W CC TC=0/+12	01121	FB5105
A1R25	0483-3345	1	RESISTOR 330K 5% .25W FC TC=-400/+900	01121	C83345

See Introduction to this section for ordering information

Table 4-3. Replaceable Parts, A1 Series 1548 (Continued)

Reference Designation	HP Part Number	Qty	Description	Mfr Code	Mfr Part Number
A1R26	0683-5115	1	RESISTOR 510 5% .25W PC TC=400/+600	01121	C85115
A1R27	0683-5115	1	RESISTOR 510 5% .25W PC TC=400/+600	01121	C85115
A1R28	0683-7525	1	RESISTOR 7.5K 5% .25W PC TC=400/+700	01121	C87525
A1E1	3101-1667	1	SWITCH-SL SPDT-MS SUBMIN .5A 125VAC PC	29480	3101-1667
A1E2			NOT ASSIGNED		
A1E3	3101-0680	1	SWITCH-PS DPST ALTMS 4A 250VAC	29480	3101-0680
A1U1	1820-1180	1	IC, DIGITAL *FACTORY SELECTED PART	29480	1820-1180
A1U2	1820-0176	1	IC:77L HEX INVERTER	01295	SN7404M
A1U3	1820-0693	1	IC SN745 74 N FLIP-FLOP	01295	SN74574M
A1U4	1820-0661	1	IC SN74 32 N GATE	01295	SN7432M
A1U5	1820-0328	1	IC:77L QUAD 2-INPUT NOR GATE	01295	SN7402M
A1U6	1820-0629	2	IC SN745 112 N FLIP-FLOP	01295	SN745112M
A1U7	1820-0681	1	IC SN745 00 N GATE	01295	SN74500M
A1U8	1820-0099	1	IC:SN7493M	01295	SN7493M
A1U9	1820-0634	1	IC COUNTER	29480	1820-0634
A1U10	1820-0629	1	IC SN745 112 N FLIP-FLOP	01295	SN745112M
A1U11	1820-0216	1	IC:77L BCD-TO-DECIMAL DECODER	01295	SN7442M
A1U12	1820-0289	1	IC:SN7483M	01295	SN7483M
A1U13	1820-0301	1	IC:SN7475M	01295	SN7475M
A1U14	1820-1224	1	IC MC10216P INVR	04713	MC10216P
A1U15	1820-0122	1	IC V REGTR	07263	7905UC
A1V1	0410-0551	1	CRYSTAL, QUARTZ 1 MHz	29480	0410-0551

See introduction to this section for ordering information

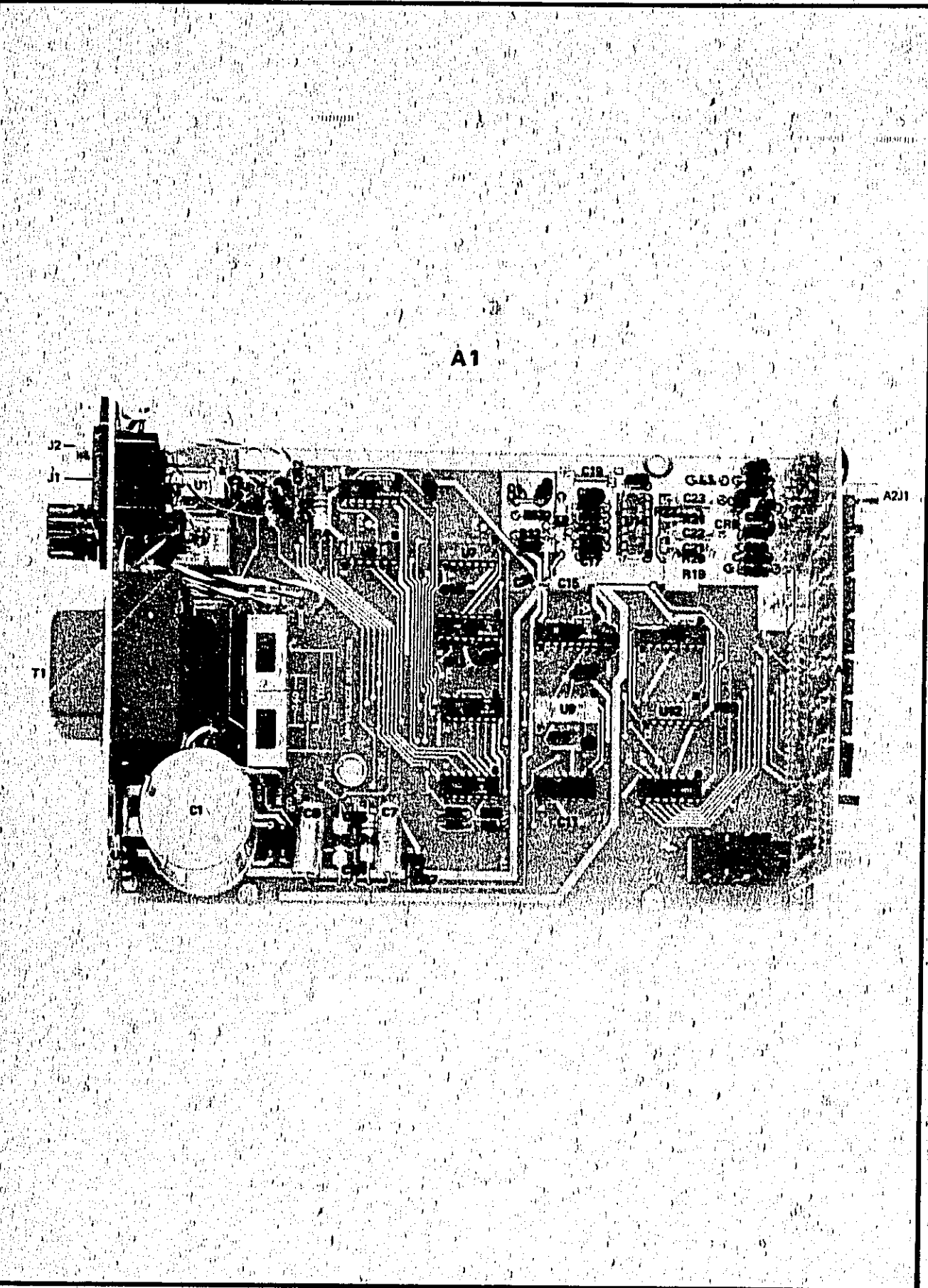

Part of Figure 4-1. A1 (05381-60001) Series 1404 Component Locator

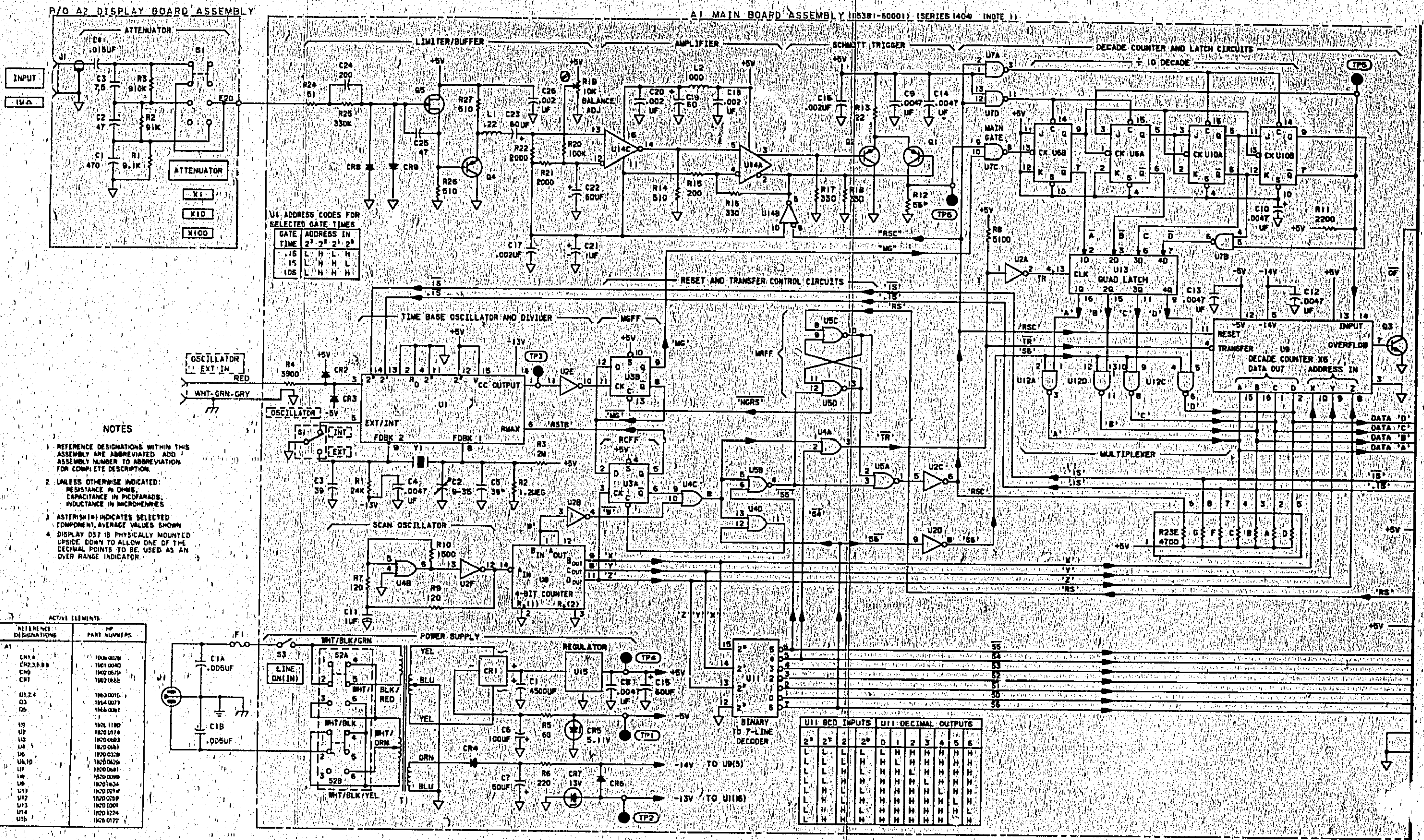

# BACKDATING

Figure 4-1. Manual Backdating A1 Main Board, Schematic Diagram/Component Locator, Series 1404 Board Part No. 05381-60001



# MANUAL CHANGES



ERRATA

Page 3-23, Figure 3-7, A1 (05381-60006) Schematic Diagram:

>Change connections to A1U6 & A1U10 decade divider (in A1 upper right corner) as follows:

Delete connection between U10A pins 2 and 3.

Delete connection between U6A pin 2 and +5V.

Add a connection between U6A(2) and junction of U6A(5) and U10A(3).

Add a connection between U10A(2) and U10B(9).

>Add "U12B" to unmarked NAND gate between U12C and U9.

>Change the value of R3 to 5.6M.

Page 3-22, A1 (05381-60006) ACTIVE ELEMENTS table:

>Change HP Part Number of A1CR4 to 1901-0028.

**CHANGE 1**

Pages 3-13 and 3-14, Table 3-3, A1 (05381-60006) Replaceable Parts and  
 Pages 3-17 and 3-18, Table 3-5, A1 OPTION 001 (05381-60007) Replaceable Parts:

- >Change both A1 SERIES numbers to 1732.
- >Change A1CR1 to 1906-0096; DIODE-MULT FULL WAVE BRIDGE RECTIFIER (1906-0028)
- NOTE: TERMINALS ON THE 1906-0096 BRIDGE ARE IN A STRAIGHT LINE; THE 1906-0028  
 TERMINALS ARE IN A RECTANGULAR PATTERN. THE SERIES 1732 CIRCUIT BOARD  
 WILL ACCEPT THE 1906-0096 BRIDGE WITH FOUR IN-LINE TERMINALS.
- >Change A1U2 to 1820-1199; IC TTL LS HEX INVERTER (SN74LS04N)
- >Change A1U4 to 1820-1208; IC TTL LS QUAD 2-INPUT OR GATE (SN74LS32N)
- >Change A1U5 to 1820-1144; IC TTL LS QUAD 2-INPUT NOR GATE (SN74LS02N)
- >Change A1U8 to 1820-1478; IC TTL LS BINARY COUNTER ASYNCHRO (SN74LS93N)
- >Change A1U12 to 1820-1198; IC TTL LS QUAD 2-INPUT NAND GATE (SN74LS03N)
- >Change A1U13 to 1820-1411; IC TTL LS LATCH 4-BIT D-TYPE (SN74LS75N)

Page 3-22, ACTIVE ELEMENTS table for A1:

- >Change HP part number for A1CR1 to 1906-0096.
- >Change HP part numbers for A1U2, U4, U5, U8, U12, and U13 to the part  
 numbers given above.

Page 3-23, A1 Main Board Assembly Schematic Diagram:

- >Change A1 SERIES number at top of the diagram to 1732.

**CHANGE 2**

Page 3-15, Table 3-3, CHASSIS & MISCELLANEOUS Replaceable Parts:

- >Change C1 to 0160-0676; CAPACITOR-FXD DUAL 0.0018uF CER
- >Change XF1 (2110-0464) to 2110-0564; FUSEHOLDER-BODY EXTR-POST BAYONET CU 12A  
 250V
- >Change 2110-0465 to 2110-0565; FUSEHOLDER-CAP BAYONET
- >Change 2950-0054 to 2110-0569; FUSEHOLDER-MTG NUT HEX METRIC

Page 3-23, Figure 3-7, A1 Main Board Assembly Schematic Diagram:

- >Change the value of C1A and C1B (ac power line filters) to 0.0018uF.
- >Add a connection between A1U1(5) and the +5VDC supply.

**CHANGE 3**

Page 3-23, Figure 3-7, A1 Main Board Assembly Schematic Diagram:

- >Change wiring for LINE ON(IN) switch A1S3 as shown in the following diagram:

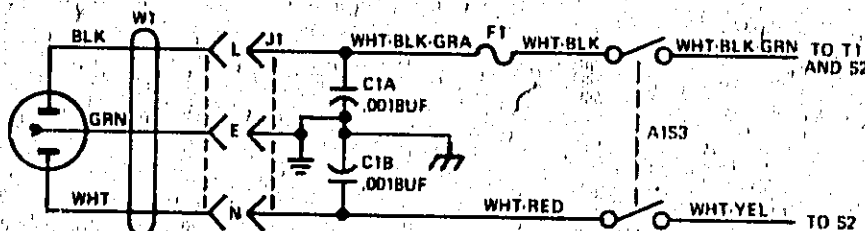

CHANGE 4

Page 3-15, Table 3-3, CHASSIS & MISCELLANEOUS Replaceable Parts:

- >Delete dual capacitor C1 (0160-0676).
- >Add C2 and C3; 0160-4281; CAPACITOR-FXD 2200PF +/-20% 250VAC (RMS)

Page 3-23, Figure 3-7, A1 (05381-60006) Schematic Diagram:

- >Change C1A to C2 with a value of 2200 PF.
- >Change C1B to C3 with a value of 2200 PF.

NOTE: Make the same changes to the diagram in CHANGE 3 of these Manual Changes.

CHANGE 5

INSTRUMENTS WITH SERIAL NUMBERS 2028A12786 THRU 2028A12927 HAVE CHANGES 1 THRU 4 ONLY.

Page 3-13, Table 3-3, A1 (05381-60006) Replaceable Parts:

- >Change A1 SERIES number to 2028.
- >Change A1C7 to 0180-3010 CAPACITOR-FXD; 100UF +100-10% 50VDC AL

Page 3-23, Figure 3-7, A1 Main Board Assembly Schematic Diagram:

- >Change A1 SERIES number to 2028.

CHANGE 6

Page 3-15, Table 3-3, CHASSIS & MISCELLANEOUS Replaceable Parts:

- >Change Front Panel to 7101-0566.
- >Add Front Panel RFI clips; 05300-00006; 4; CLIPS, FRONT PANEL
- >Add REV. M to description of the Rear Panel (Standard Instrument).
- >Change the Rear Panel (Option 001) to 05381-00003-1.
- >Add REV. E to description of the Rear Panel (Option 001).
- >Add 0360-1632; GROUND LUG-BNC CONNECTOR

CHANGE 7

Page 3-13, Table 3-3, A1 (05381-60006) Replaceable Parts:

- >Change A1 SERIES number to 2040.
- >Change A1CR7 to 1902-3171; DIODE-ZNR 11V 5% DO-35 PD=.4W TC=>.062%
- >Change A1R6 to 0686-1325; RESISTOR 1.3K 5% .5W CC TC=0+647

Page 3-22, ACTIVE ELEMENTS Table for A1:

- >Change A1CR7 to part number 1902-3171.

Page 3-23, Figure 3-7, A1 Main Board Assembly Schematic Diagram:

- >Change the value of R6 to 1.3K.
- >Change the voltage rating of CR7 to 11V.
- >Change "-13V" to VGG at the outputs labeled "to U9(5)" and "to U1(16)", near TP2.
- >Change the voltage at U1(16) from "-13V" to VGG.
- >Change the label at U1(5) from "NC" to +5V.
- >Change the voltage at U9(5) from "-13V" to VGG.

CHANGE 8

Page 3-15, Table 3-3, CHASSIS & MISCELLANEOUS Replaceable Parts:

- >Change the HP Part Number for S1 and S2 from 3101-1598 to 3101-2383.
- >Change F1 (2110-0008) to 2110-0202; FUSE .5A 250V TD 1.25X.25 UL.

**CHANGE 9**

Page 3-13, Table 3-3. A1 (05381-60006) Board Assembly-Main Replaceable Parts:

- >Change A1 SERIES from 2040 to 2310.
- >Change A1U9 from 1820-0634 to 1820-2316.
- >Add R33, 0683-1525 RESISTOR 1.5K 5% .25W CF TC=0-400.
- >Add C30, 0160-0576 CAPACITOR-FXD .1UF +-20% 50VDC CER.

Page 3-17, Table 3-17. A1 (05381-60007) Board Assembly-Main (Opt 001) Replaceable Parts:

- >Change A1 SERIES from 2040 to 2310.
- >Change A1U9 from 1820-0634 to 1820-2316.
- >Add R33, 0683-1525 RESISTOR 1.5K 5% .25W CF TC=0-400.
- >Add C30, 0160-0576 CAPACITOR-FXD .1UF +-20% 50VDC CER.

Page 3-23, Figure 3-7. 5381A Overall Schematic Diagram:

- >Change SERIES from 2028 to 2310.
- >Connect U9, Pin 5 to ground, instead of VGG.
- >Add R33 1.5K Resistor (0683-1525) between U9(7) and the base of Q3.
- >Add C30 0.1 UF bypass capacitor (0160-0576) from +5 to ground near U9.

**#CHANGE 10**

Page 3-13, Table 3-3. A1 (05381-60006) Replacement Parts:

- >Change R8 from 0683-5125 to 0683-4725 RESISTOR 4.7K 5% .25W CF TC=0-400.

Page 3-17, Table 3-5. A1 Option 001 (05381-60007) Replaceable Parts:

- >Change R8 from 0683-5125 TO 0683-4725 RESISTOR 4.7K 5% .25W CF TC=0-400.

Page 3-23, Figure 3-7. 5381A Overall Schematic Diagram:

- >Change value of R8 from 5.1K to 4.7K.

# MANUAL CHANGES

**MANUAL UPDATING CHANGES**

**CHANGE DATE:** April 9, 1984

**\*\*\* MANUAL UPDATING COVERAGE \*\*\***

\* This supplement adapts your manual  
\* to instruments with serial numbers  
\* prefixed through 2#16.

\*\*\*\*\*

**\*\*\* MANUAL IDENTIFICATION \*\*\***

\* **Instrument:** HR 5381A  
\* Frequency Counter  
\* Operating & Service  
\* Manual

\* **Manual Part No:** 05381-90010

\* **Manual Microfiche:** 05381-90011

\* **Manual Print Date:** OCT 1976

\*\*\*\*\*

**ABOUT THIS SUPPLEMENT**

The information in this manual is provided to correct manual errors and to adapt the manual to instruments containing changes after the manual print date.

Change and correction information in this supplement is itemized by page numbers corresponding to the original manual pages. The pages in this supplement are organized in numerical order by manual page number.

Manual updating supplements are revised as often as necessary to keep manuals as accurate as possible. Hewlett-Packard recommends that you periodically request the latest edition of this supplement. Free copies are available from all HP offices. When requesting copies quote the model number, print date, and part number listed at the top of this page.

**HOW TO USE THIS SUPPLEMENT**

Insert this title page in front of the title page in your manual.

Perform all changes specified for "All Serials", and all changes through the Series Prefix of your instrument or board.

Insert any complete replacement pages provided into your manual in the proper location.

If your manual has been updated according to the last edition of this supplement, you need only perform those changes pertaining to the new series prefix. See List of Effective Pages on the reverse side of this page. New information affecting "All Serials" will be indicated by a "#" in front of the page number.

LIST OF EFFECTIVE PAGES

\*\*\*\*\*  
SERIAL PREFIX OR  
SERIAL NUMBER                      PAGES  
\*\*\*\*\*

All Series	3-22, 3-23
1732A	3-13, 3-14, 3-17, 3-18, 3-22, 3-23
1816A	3-15, 3-23
1924A	3-23, 3-23
1948A	3-15, 3-23
2028A	3-13, 3-23
2032A	3-15
2040A	3-13, 3-22, 3-23
2112A	3-15
2310A	3-13, 3-16, 3-17, 3-23
2416A	3-13, 3-23

-----  
(5381A)7083/7441/7984/9484/9498-9579/2028A=9898/2032A=10461, 10901/2040A=10815/  
2112A=11634, 14864/2310A=14238, 14903/2416A=15265

3

MANUAL CHANGES MODEL 5381A (05381-90010)

---

SERIAL PREFIX OR  
SERIES NUMBER

CHANGES

---

Page 3-13, Table 3-3. A1 (05381-60006) Replaceable Parts:

- 1732A >Change A1 SERIES to 1732.  
>Change CR1 to 1906-0096 DIODE-MULT FULL-WAVE BRIDGE RECTIFIER (1906-0028).
- NOTE**
- Terminals on the 1906-0096 Bridge are in a straight line; the 1906-0028 terminals are in a rectangular pattern. The series 1732 circuit board will accept the 1906-0096 bridge with four in-line terminals.
- 2028A Change indicated for 2028A do not apply to instruments with serial numbers 2028A12786 thru 2028A12927.  
>Change A1 SERIES to 2028.  
>Change C7 to 0180-3010 CAPACITOR-FXD 100UF +100-10% 50VDC AL.
- 2040A >Change A1 SERIES to 2040.  
>Change CR7 to 1902-3171 DIODE-ZNR 11V 5% DO-35 PD= .4W TC=+.062%.  
>Change R6 to 0686-1325 RESISTOR 1.3K 5% .5W CC TC=0+64%
- 2310A >Change A1 SERIES to 2310.  
>Add C30 0160-0576 CAPACITOR-FXD .1UF +-20% 50VDC CER.  
>Change R8 from 0683-5125 to 0683-4725 RESISTOR 4.7K 5% .25W CF TC=0-400.  
>Add R33 0683-1525 RESISTOR 1.5K 5% .25W CF TC=0-400.  
>Change U9 from 1820-0634 to 1820-2316.
- 2416A >Change A1 SERIES to 2416.  
>Add C31 0160-3874 CAPACITOR-FXD 10PF 200V CER.

Page 3-14, Table 3-3. A1 (05381-60006) Replaceable Parts:

- 1732A >Change A1U2 to 1820-1199 IC-TTL LS HEX INVERTER (SN74LS04N).  
>Change A1U4 to 1820-1208 IC-TTL LS QUAD 2-INPUT OR GATE (SN74LS32N).  
>Change A1U5 to 1820-1144 IC-TTL LS QUAD 2-INPUT NOR GATE (SN74LS02N).  
>Change A1U8 to 1820-1478 IC-TTL LS BINARY COUNTER ASYNCHRO (SN741S93N).  
>Change A1U12 to 1820-1198 IC-TTL LS QUAD 2-INPUT NAND GATE (SN74LS03N).  
>Change A1U13 to 1820-1411 IC-TTL LS LATCH 4-BIT D-TYPE (SN74LS75N).

4

MANUAL CHANGES MODEL 5381A (05381-90010)

SERIAL PREFIX OR  
SERIES NUMBER

CHANGES

Page 3-15, Table 3-3. Chassis & Miscellaneous Replaceable Parts:

- 1816A >Change C1 to 0160-0676 CAPACITOR-FXD DUAL 0.0018uF CER.  
>Change XF1 (2110-0464) to 2110-0564 FUSEHOLDER-BODY  
EXTR-POST BAYONET CU 12A 250V.  
>Change 2110-0465 to 2110-0565 FUSEHOLDER-CAP BAYONET.  
>Change 2950-0054 to 2110-0569 FUSEHOLDER-MTG NUT HEX  
METRIC.
- 1948A >Delete dual capacitor C1 (0160-0676).  
>Add C2 and C3 0160-4281 CAPACITOR-FXD 2200PF +/-20% VAC  
(RMS).
- 2032A >Change Front Panel part number to 7101-0566.  
>Add Front Panel RFI clips; 05300-00006, Qty 4, CLIPS-  
FRONT PANEL.  
>Add REV. M to description of the Rear Panel (Standard  
Instrument).  
>Change the Rear Panel (Option 001) to 05381-00003-1.  
>Add REV. E to description of the Rear Panel (Option 001).  
>Add 0360-1632 GROUND LUG-BNC CONNECTOR.
- 2112A >Change the HP Part Number for S1 and S2 from 3101-1598 to  
3101-2383.  
>Change F1 (2110-0008) to 2110-0202 FUSE .5A 250V TD  
1.25X.25 UL.
- 2416A >Change A1 SERIES to 2416.  
>Add C30 0150-3874 CAPACITOR-FXD 10PF 200V CER.

Page 3-17, Table 3-5. A1 (05381-60007) Replaceable Parts, Option 001:

- 1732A >Change A1 SERIES to 1732.  
>Change A1CR1 to 1906-0096 DIODE-MULT FULL-WAVE BRIDGE  
RECTIFIER (1906-0028).
- NOTE
- Terminals on the 1906-0096 Bridge are in a straight  
line; the 1906-0028 terminals are in a rectangular  
pattern. The series 1732 circuit board will accept  
the 1906-0096 bridge with four in-line terminals.
- 2310A >Change A1 SERIES to 2310.  
>Add C30 0160-0576 CAPACITOR-FXD .1UF +/-20% 50 VDC CER.  
>Change R8 from 0683-5125 to 0683-4725 RESISTOR 4.7K 5%  
.25W CF TC=0-400.  
>Add R33 0683-1525 RESISTOR 1.5K 5% .25W CF TC=0-400.  
>Change U9 from 1820-0634 to 1820-2316.

SERIAL PREFIX OR  
SERIES NUMBER

CHANGES

Page 3-18, Table 3-5. A1 (05381-60007) Replaceable Parts, Option 001:

- 1732A
  - >Change U2 to 1820-1199 IC TTL LS HEX INVERTER (SN74LS04N).
  - >Change U4 to 1820-1208 IC-TTL LS QUAD 2-INPUT OR GATE (SN74LS32N).
  - >Change A1U5 to 1820-1144 IC-TTL LS QUAD 2-INPUT NOR GATE (SN74LS02N).
  - >Change A1U8 to 1820-1478 IC-TTL LS BINARY COUNTER ASYNCHRO (SN74LS93N).
  - >Change A1U12 to 1820-1198 IC-TTL LS QUAD 2-INPUT NAND GATE (SN74LS03N).
  - >Change A1U13 to 1820-1411 IC-TTL LS LATCH 4-BIT D-TYPE (SN74LS75N).

Page 3-22, Figure 3-7. A1 (05381-60006) Active Elements:

- All Serials
  - >Change HP Part Number of A1CR4 to 1901-0028.
- 1732A
  - >Change HP Part Number for A1CR1 to 1906-0096.
  - >Change HP Part Numbers for the following:
    - U2 to 1820-1199.
    - U4 to 1820-1208
    - U5 to 1820-1144
    - U8 to 1820-1478
    - U12 to 1820-1198
    - U13 to 1820-1411
- 2040A
  - >Change A1CR7 TO PART NUMBER 1902-3171.

Page 3-23, Figure 3-7. A1 (05381-60006) Main Board Assembly:

- All Serials
  - >Change connections to A1U6 and A1U10 decade divider (in A1 upper right corner) as follows:
    - Delete connection between U10A pins 2 and 3.
    - Delete connection between U6A pin 2 and +5.
    - Add a connection between U6A(2) and junction of U6A(5) and U10A(3).
    - Add a connection between U10A(2) and U10B(9).
  - >Add "U12B" to unmarked NAND gate between U12C and U9.
  - >Change the value of R3 to 5.6M.
- 1732A
  - >Change A1.SERIES to 1732.
- 1816A
  - >Change the value of C1A and C1B (ac power line filters) to 0.0018uF.
  - >Add a connection between A1U1(5) and the +5VDC supply.
- 1924A
  - >Change wiring for LINE (ON)IN switch A1S3 as shown in the following diagram:

MANUAL CHANGES MODEL 5381A (05381-90010)

SERIAL PREFIX OR  
SERIES NUMBER

CHANGES

Page 3-23, Figure 3-7. A1 (05381-60006) Main Board Assembly:

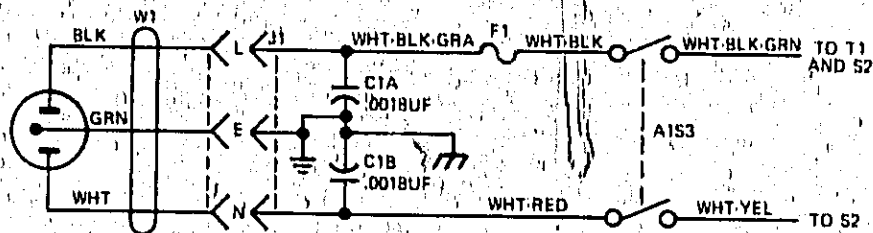

1948A

- >Change C1A to C2 with a value of 2200 PF.
- >Change C1B to C3 with a value of 2200 PF.

2028A

Changes indicated for 2028A do not apply to instruments with serial numbers 2028A12786 thru 2028A12927.

- >Change A1 SERIES to 2028.

2040A

- >Change the value of R6 to 1.3K.
- >Change the voltage rating of CR7 to 11V.
- >Change "-13V" to VGG at the outputs labeled "to U9(5)" and "to U1(16)", near TP2.
- >Change the voltage at U1(16), from "-13V" to VGG.
- >Change the label at U1(5) from "NC" to +5V.
- >Change the voltage at U9(5) from "-13V" to VGG.

2310A

- >Change A1 SERIES to 2310.
- >Connect U9 Pin 5 to ground, instead of VGG.
- >Change value of R8 from 5.1K to 4.7K.
- >Add R33 1.5K Resistor (0683-1525) between U9(7) and the base of Q3.
- >Add C30 0.1 UF bypass capacitor (0160-0576) from +5 to ground near U9.

2416A

- >Change A1 SERIES to 2416.
- >Add C31 10PF Capacitor from the input of A1U9, between Pins 3 and 14, to ground.