

Errata

Title & Document Type: 4437A Attenuator Operating and Service Manual

Manual Part Number: 04437-90003

Revision Date: November 1981

About this Manual

We've added this manual to the Agilent website in an effort to help you support your product. This manual provides the best information we could find. It may be incomplete or contain dated information, and the scan quality may not be ideal. If we find a better copy in the future, we will add it to the Agilent website.

HP References in this Manual

This manual may contain references to HP or Hewlett-Packard. Please note that Hewlett-Packard's former test and measurement, life sciences, and chemical analysis businesses are now part of Agilent Technologies. The HP XXXX referred to in this document is now the Agilent XXXX. For example, model number HP8648A is now model number Agilent 8648A. We have made no changes to this manual copy.

Support for Your Product

Agilent no longer sells or supports this product. You will find any other available product information on the Agilent Test & Measurement website:

www.agilent.com

Search for the model number of this product, and the resulting product page will guide you to any available information. Our service centers may be able to perform calibration if no repair parts are needed, but no other support from Agilent is available.

OPERATING AND SERVICE MANUAL

ATTENUATOR 4437A

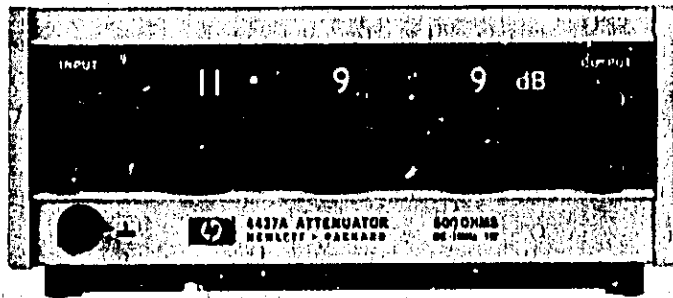

CERTIFICATION

The Hewlett-Packard Company certifies that this instrument was thoroughly tested and inspected and found to meet its published specifications when it was shipped from the factory. The Hewlett-Packard Company further certifies that its calibration measurements are traceable to the U.S. National Bureau of Standards to the extent allowed by the Bureau's calibration facility.

WARRANTY AND ASSISTANCE

All Hewlett-Packard products are warranted against defects in materials and workmanship. This warranty applies for one year from the date of delivery, or, in the case of certain major components listed in the operating manual, for the specified period. We will repair or replace products which prove to be defective during the warranty period provided they are returned to Hewlett-Packard. No other warranty is expressed or implied. We are not liable for consequential damages.

Service contracts or customer assistance agreements are available for Hewlett-Packard products that require maintenance and repair on-site.

For any assistance, contact your nearest Hewlett-Packard Sales and Service Office. Addresses are provided at the back of this manual.

OPERATING AND SERVICE MANUAL

MODEL 4437A ATTENUATOR

SERIALS PREFIXED : 1250

See Section VII for Other Serial Prefixes.

COPYRIGHT, YOKOGAWA-HEWLETT-PACKARD, LTD., 1971
9-1, TAKAKURA-CHO, HACHIOJI-SHI, TOKYO, JAPAN

Manual Part No. 04437-90003
Microfiche Part No. 04437-90053

Printed: NOV. 1981



**HEWLETT
PACKARD**

TABLE OF CONTENTS

Section	Title	Page	Section	Title	Page
I	GENERAL INFORMATION	1-1	V	MAINTENANCE	5-1
	1-1. Introduction	1-1		5-1. Introduction	5-1
	1-4. Identification	1-1		5-3. Test Equipment	5-1
	1-6. Specification	1-1		5-5. Resistance Measurements	5-1
	1-8. Installation and Operation	1-1		5-7. In-Cabinet Performance Check	5-1
II	INSTALLATION	2-1		5-8. General	5-1
	2-1. Introduction	2-1		5-10. AC Performance Test	5-1
	2-3. Unpacking and Inspection	2-1		5-14. Cover Removal	5-3
	2-5. Storage and Shipment	2-1		5-16. Component Replacement	5-3
	2-6. Packaging	2-1		5-17. Replacement of Spring Contacts	5-3
	2-7. Environment	2-1		5-19. Replacement of Molded Slides	5-4
	2-8. Installation	2-1		5-21. Replacement of Resistors	5-4
	2-10. Adapter Frame	2-1		5-23. Preventive Maintenance	5-4
III	OPERATION	3-1		5-25. Cleaning	5-4
	3-1. Introduction	3-1		5-27. Lubrication	5-4
	3-3. Controls and Connectors	3-1		5-29. Electrical Check	5-5
	3-5. Operating Considerations	3-1		5-31. Troubleshooting	5-5
	3-6. Impedance	3-1		5-33. Contact Resistance Check for Switches	5-5
	3-8. Leads and Connections	3-1	VI	REPLACEABLE PARTS	6-1
	3-11. Input Power Limitation	3-1		6-1. Introduction	6-1
	3-13. Operating Procedures	3-1		6-4. Ordering Information	6-1
	3-14. Matched Impedance	3-1	VII	MANUAL CHANGES AND OPTIONS	7-1
	3-17. Use of Impedance-Matching Circuit	3-3		7-1. Options	7-1
	3-20. Need for Input Match	3-4		7-3. Special Instruments	7-1
	3-21. Matching at the Input	3-4		7-5. Manual Changes	7-1
	3-22. Need for Output Matching	3-5		7-7. Later Instruments	7-1
	3-23. Matching at the Output	3-5		7-8. Earlier Instruments (Backdating Changes)	7-1
IV	THEORY OF OPERATION	4-1	VIII	CIRCUIT DIAGRAM	8-1
	4-1. General	4-1		8-1. Introduction	8-1
	4-3. Attenuation Expressed in Decibels	4-1		8-3. General Notes	8-1
	4-4. Power and Voltage Ratios	4-1			
	4-7. Reference to dB	4-2			

LIST OF TABLES

Number	Title	Page	Number	Title	Page
1-1.	Specifications	1-0	5-5.	Resistance between OUTPUT and Switch Resistors	5-6
3-1.	Matching Network Values	3-4	6-1.	List of Reference Designators and Abbreviations	6-1
3-2.	Attenuation Factors	3-7	6-2.	Replaceable Parts	6-2
5-1.	Test Equipment Required	5-1	7-1.	Backdating Changes	7-1
5-2.	AC Performance Test A	5-2			
5-3.	AC Performance Test B	5-3			
5-4.	AC Performance Test C	5-3			

LIST OF ILLUSTRATIONS

Number	Title	Page	Number	Title	Page
1-1.	Model 4437A Attenuator	1-0	3-11.	Output Matching with Shunt Resistor	3-5
3-1.	Measurement and/or Test Set-up Connections	3-0	3-12.	Output Matching with Resistive Network	3-5
3-2.	Front Panel Controls and Connectors	3-2	3-13.	Output Matching with Transformer	3-5
3-3.	Impedance Matched Connection	3-3	4-1.	Model 4437A Simplified Circuit	4-1
3-4.	Input Impedance Change Due to Terminated Resistance Error ..	3-3	5-1.	AC Performance Test Set-up	5-2
3-5.	Attenuation Change Due to Terminated Resistance Error ..	3-3	5-2.	Abrasive Stick	5-4
3-6.	Simple Input Matching with Series Resistor	3-4	5-3.	Molded Slide	5-4
3-7.	Input Matching with Transformer ...	3-4	5-4.	Contact Cleaning	5-5
3-8.	Input Matching with Resistive Network	3-4	5-5.	Contact Resistance Check (1)	5-5
3-9.	Resistive Matching Network	3-4	5-6.	Contact Resistance Check (2)	5-5
3-10.	Simple Output Matching with Series Resistor	3-5	8-1.	Board Assembly	8-2
			8-2.	Cam Assembly	8-3
			8-3.	Front Panel	8-3
			8-4.	Schematic Diagram	8-5

Table 1-1. Specifications

Frequency Range: dc to 1 MHz.
Maximum Attenuation: 119.9 dB.
Attenuation Increments: 0.1 dB.
Accuracy:

Attenuation	100kHz	1MHz	1.5MHz
0 to 60 dB	±0.1 dB	±0.2 dB	±0.2 dB*
60 to 90 dB	±0.1 dB	±0.3 dB	±0.3 dB
90 to 110 dB	±0.2 dB	±0.5 dB	±0.5 dB
110 to 119.9 dB	±0.3 dB	±1.0 dB	

* typical values

Dimensions:

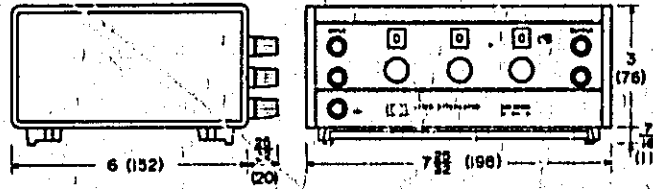

Input/Output Impedance: 600Ω, unbalanced.

Input/Output Impedance Accuracy(at 100kHz):
600Ω ± 10Ω.

Maximum Input Power: 1W (24.5V max.).

DC Isolation: Signal ground may be ±300V dc from external chassis.

Operating Temperature: 0°C - 65°C

Weight: Net 3 lb 5 oz (1.5kg).
Shipping 6 lb (2.7kg).



Figure 1-1. Model 4437A Attenuator.

SECTION I GENERAL INFORMATION

1-1. INTRODUCTION

1-2. The HP4437A (Figure 1-1) is an in-line reading variable attenuator usable from dc to 1.5 MHz. The 4437A uses unbalanced-type pads and its input and output impedances are 600 ohms. This attenuator provides accurate 0.1 dB steps of attenuation up to 119.9 dB giving excellent resolution for power-level measurements, transmission efficiency tests, and gain or loss measurements on filters and amplifiers, and similar equipment.

1-3. Printed-circuit switches and a unique drive mechanism are utilized. The unit is compact, light weight and rugged. The drive mechanisms, controlled from the front panel, are three rotary shafts on which are mounted four-pairs of cams. Each rotary shaft drives four printed-circuit switches. The switches set up the connections, in a proper sequence to obtain desired degree of attenuation, to four T-type attenuator pads. The 4437A has pads of 0.1, 0.2, 0.3, 0.3, 1, 2, 3, 10, 20, 40, and 40 decibels which allow a range of 0 to 119.9 dB in 0.1 dB steps.

1-4. IDENTIFICATION

1-5. Hewlett-Packard uses a two-section ten-char-

acter (0000J00000) serial number. The first four digits (serial prefix) identify a series of instruments; the last five digits identify a particular instrument in that series. A letter placed between the two sections identifies the country where the instrument was manufactured, i.e., A = U.S.A., E = England, G = West Germany, J = Japan, and U = United Kingdom. If the first four digits of the instrument serial number are not the same as those on the title page, change sheets included with this manual will define any differences between other instruments and the Model 4437A described herein. If the change sheets are missing, your HP Sales and Service Office can supply the information (addresses are listed at the rear of this manual).

1-6. SPECIFICATIONS

1-7. A complete list of specifications is found in Table 1-1.

1-8. INSTALLATION AND OPERATION

1-9. Installation, storage and shipping procedures are described in Section II. An explanation of controls, connectors, and operational procedures is contained in Section III.

SECTION II INSTALLATION

2-1. INTRODUCTION

2-2. This section contains information for unpacking, inspection, repackaging, storage and installation of the Model 4437A.

2-3. UNPACKING AND INSPECTION

2-4. If the shipping carton is damaged, ask that the carrier's agent be present when the instrument is unpacked. Inspect the instrument for damage (scratches, dents, broken knobs, etc.). If the instrument is damaged or fails to meet specifications, notify the carrier and the nearest Hewlett-Packard Field Office (see list at back of this manual). Retain the shipping carton and the padding material for the carrier's inspection. The field office will arrange for the repair or replacement of your instrument without waiting for the claim against the carrier to be settled.

2-5. STORAGE AND SHIPMENT

2-6. **PACKAGING.** To protect valuable electronic equipment during storage or shipment always use the best packaging methods available. Your Hewlett-Packard field office can provide packing material such as that used for original factory packaging. Contract packaging companies in many cities can provide dependable custom packaging on short notice. Here are a few recommended packaging methods.

- a. **RUBBERIZED HAIR.** Cover painted surfaces of instrument with protective wrapping paper. Pack instrument securely in strong corrugated container (350 lb/sq in. bursting test) with 2-

inch rubberized hair pads placed along all surfaces of the instrument. Insert fillers between pads and container to ensure a snug fit.

- b. **EXCELSIOR.** Cover painted surfaces of instrument with protective wrapping paper. Pack instrument in strong corrugated container (350 lb/sq in. bursting test) with a layer of excelsior about 6 inches thick packed firmly against all surfaces of the instrument.

2-7. **ENVIRONMENT.** Conditions during storage and shipment should normally be limited as follows:

- a. Maximum altitude, 20,000 feet.
- b. Minimum temperature, -40°F (-40°C).
- c. Maximum temperature, 167°F (75°C).

2-8. INSTALLATION

2-9. The Model 4437A is a submodular unit equipped with plastic feet for bench operation as shipped from the factory. However, when used in combination with other submodular units it can be rack mounted. The HP adapter frame is designed for this purpose and is available through your Hewlett-Packard Sales and Service office.

2-10. **ADAPTER FRAME** (HP Part No. 5080-0808)

2-11. The adapter frame is a rack frame that accepts any combination of submodular units. It can be rack mounted only.

OPERATION

THEORY

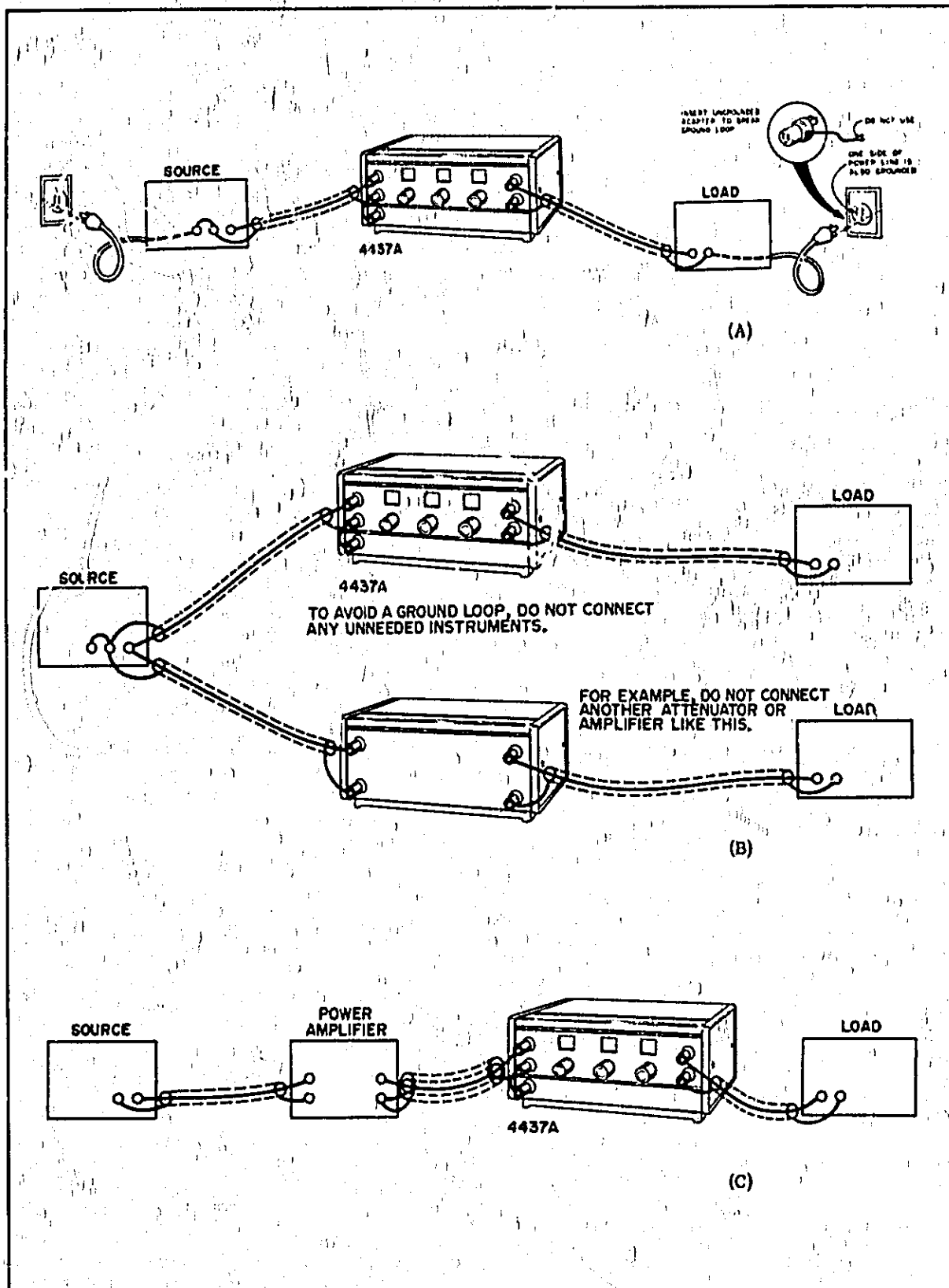

Figure 3-1. Measurement and/or Test Set-up Connections.

SECTION III OPERATION

3-1. INTRODUCTION

3-2. The Model 4437A is designed to provide attenuation up to 110.9dB with 0.1dB resolution and dissipate a maximum average power of 1W. The attenuator will be damaged if overloaded.

3-3. CONTROLS AND CONNECTORS

3-4. The front panel controls and connectors are explained in Figure 3-2. The descriptions are keyed to the corresponding items which are indicated on the figure.

3-5. OPERATING CONSIDERATIONS

3-6. IMPEDANCE

3-7. For full accuracy and ease of application, the source and load impedances should match the impedance at the INPUT and OUTPUT terminals of the Model 4437A. When source and load impedances are the same as the impedance of the Model 4437A, the amount of attenuation in the circuit is the attenuator-knob settings. If an impedance-matching network is used (see Paragraph 3-13), the amount of insertion loss must be added to the Model 4437A setting to obtain the amount of attenuation between source and load.

3-8. LEADS AND CONNECTIONS

3-9. The following describes the procedure for making connections to the Model 4437A and the other instruments for test or measurement setups. It is of especial use at high attenuator settings, (above 60dB) and at high frequencies (above 100kHz).

- a. Use shielded (coaxial) cable as short in length as possible.
- b. All terminals of the test setup and matching 600Ω resistor must be enclosed in the shield.
- c. Do not create a complete electrical circuit loop in the lower signal line. The difference current which flows through the lower signal line of Model 4437A may result in attenuation of a different value from that set on the Model 4437A controls. Do not create ground loops by making two or more ground connections. For example, do not ground lead instrument at power source (See Figure 3-1A). In addition, disconnect any instruments which are not needed for the measurement to avoid looping (See Figure 3-1B).
- d. When the 4437A input power is +20dBm or above and the attenuation is more than 60dB, the input coaxial cable should be shielded with an outer-shield. One end of the outer-shield must be disconnected from its respective con-

ductor to prevent RF current flow in the outer-shield conductor (ground loop). See Figure 3-1C.

3-10. The three connector arrangement of the INPUT terminals permit the ac input to be at a dc level (floated). Connect all inputs to left upper and middle INPUT terminals. If both input leads are shielded, connect the shields to the lower-most terminal (marked \perp) which is at cabinet ground potential. If the input is ac, but at some dc level, the load on Model 4437A must be floated, i.e., not connected to cabinet ground potential (\perp).

3-11. INPUT POWER LIMITATION

3-12. Do not apply more than 1 watt maximum to the Model 4437A INPUT terminals. For the attenuator, 1 watt corresponds to 24.5volts (dc or rms).

CAUTION

ALWAYS CONNECT INPUT TO THE INPUT TERMINALS. IF THE OUTPUT TERMINALS ARE USED AS INPUT TERMINALS LISTED SPECIFICATIONS MAY NOT BE OBTAINED.

3-13. OPERATING PROCEDURES

3-14. MATCHED IMPEDANCE

3-15. When the Model 4437A INPUT and OUTPUT terminals are terminated properly, the attenuation reading corresponds to the control settings. The voltage at the output of the Model 4437A may be determined if the input voltage (or input dB level) and the amount of attenuation inserted by the Model 4437A are known. Table 3-2 shows the attenuation factor (A) over the attenuation range of the Model 4437A in 1dB steps. The method for finding the input level in dBm, is explained in Section IV. To find the voltage at the output terminals proceed as follows:

- a. Determine the input voltage to the Model 4437A and the amount of attenuation set on the Model 4437A.
- b. Locate the amount of attenuation in the dB column of Table 3-2 and read the corresponding attenuation factor.
- c. Multiply the input voltage by the attenuation factor to find the output voltage. Paragraph 3-16, which follows, provides an example.

3-16. In figure 3-3A and B the Model 4437A is shown connected to a matching source and load. In both cases the Model 4437A is set to attenuate the signal by 24dB. The attenuation factor for 24dB from Table

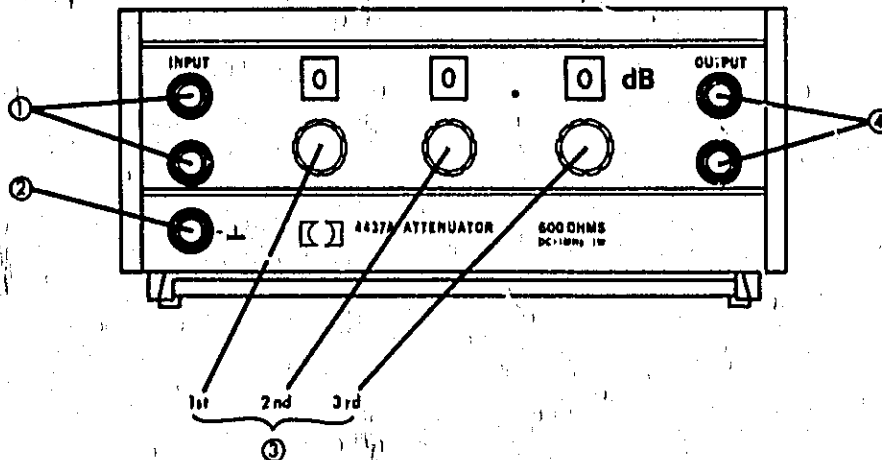

1. **INPUT terminals:** Provide input connections to source.

CAUTION

Do not apply more than 1W (24.5V) maximum to the INPUT terminals, and always connect input to the INPUT terminals.

2. **Ground terminal (⊥):** Connected to the cabinet internally.
3. **Decade Switches:** Provide attenuation up to 119.9dB between INPUT and OUTPUT terminals in steps of 0.1dB. The amount of attenuation is displayed in the windows just above the control knobs which are ganged with the switches in-line from:

1st. decade switch: provides attenuation of 0 to 110dB in 10dB steps.
2nd. decade switch: provides attenuation of 0 to 9dB in 1dB steps.
3rd. decade switch: provides attenuation of 0 to 0.9dB in 0.1dB steps.

4. **OUTPUT terminals:** Provide output connections to load.

Figure 3-2. Front Panel Controls and Connectors

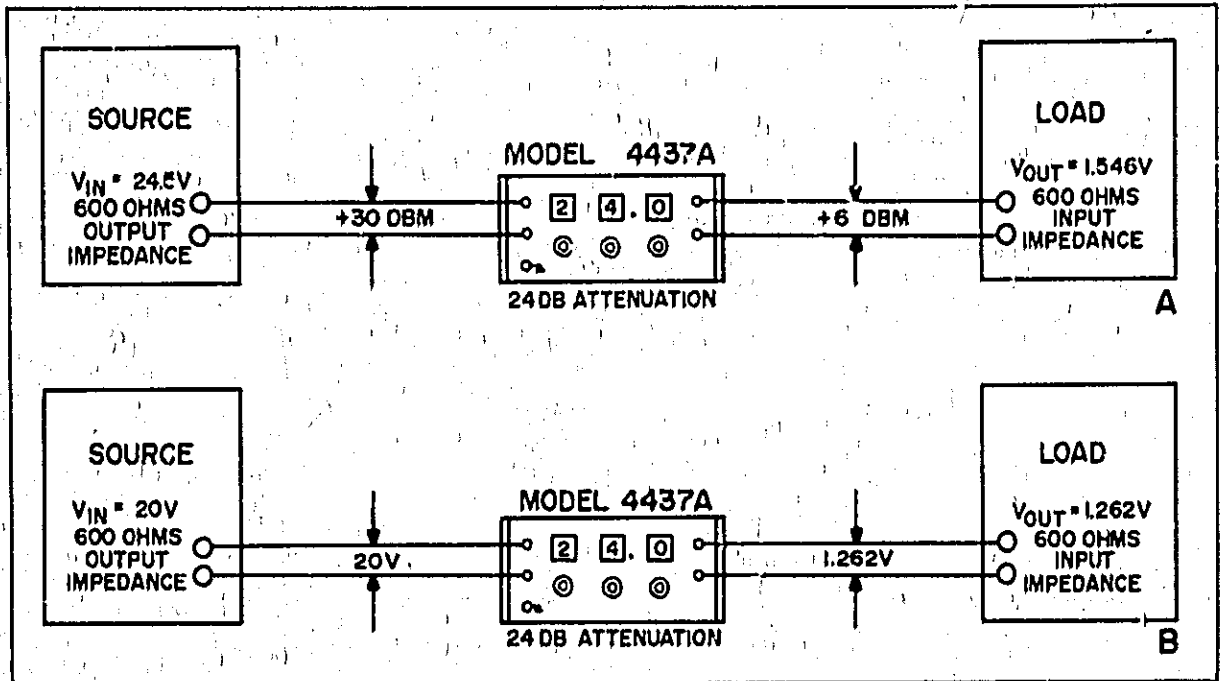

Figure 3-3. Impedance Matched Connection

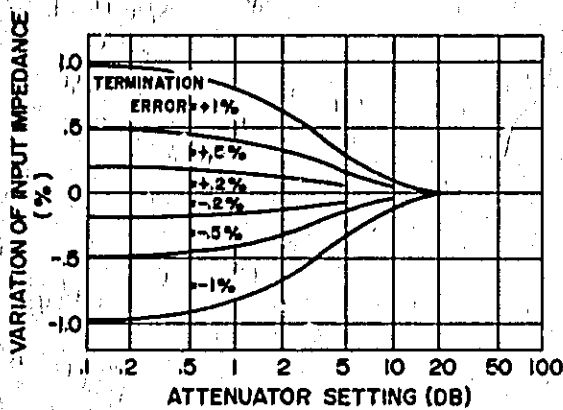

Figure 3-4. Input Impedance Change Due to Terminated Resistance Error

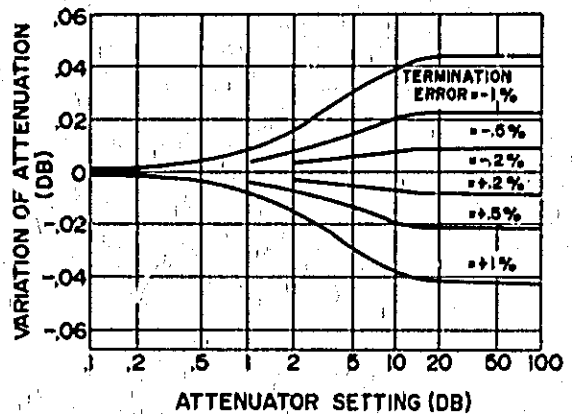

Figure 3-5. Attenuation Change Due to Terminated Resistance Error

3-2 is 0.0631 and the output voltage, for the condition shown in Figure 3-3A, is then:

$$V_{out} = (24.5V)(0.0631) = 1.546 \text{ volts}$$

For Figure 3-3B the attenuation factor is the same as for Figure 3-3A and the output voltage is:

$$V_{out} = (20V)(0.0631) = 1.262 \text{ volts}$$

3-17. USE OF IMPEDANCE-MATCHING CIRCUIT

3-18. When the Model 4437A OUTPUT terminals are terminated improperly, attenuation and input impedance may be affected with losses caused by mismatch.

Figure 3-4 and 3-5 show input impedance change due to terminated resistance error and attenuation change due to terminated resistance error, respectively. Impedance matching between load and Model 4437A is, therefore, very important. Figure 3-4 also shows that terminated resistance error does not affect the input impedance when the attenuator is set to a value greater than 20dB attenuation.

3-19. Similarly, impedance matching technique at INPUT terminals is necessary, especially in high frequency measurements or using the attenuator at low attenuation settings. Refer to paragraphs below for actual impedance matching techniques.

3-20. NEED FOR INPUT MATCH. An impedance matching circuit is necessary between source and Model 4437A Attenuator under the following conditions:

- a. Source frequency is 100kHz or above.
- b. Model 4437A is set for less than 20dB attenuation.
- c. Source output frequency response is affected by mismatched impedance.

d. Source output is monitored by meter which is accurate only when the source operates into a matched load.

3-21. MATCHING AT THE INPUT

- a. When the source is not affected by mismatch and source impedance is lower than that of Model 4437A, a series resistor may be used between source and attenuator as shown in Figure 3-6.

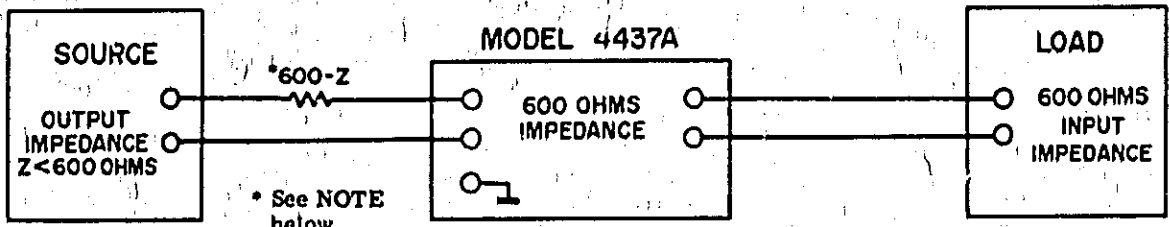

NOTE

The resistor value should be the difference between Model 4437A impedance and source impedance. For example, to match the Model 4437A to a 200Ω source requires a series resistance of 400Ω.

Figure 3-6. Simple Input Matching with Series Resistor

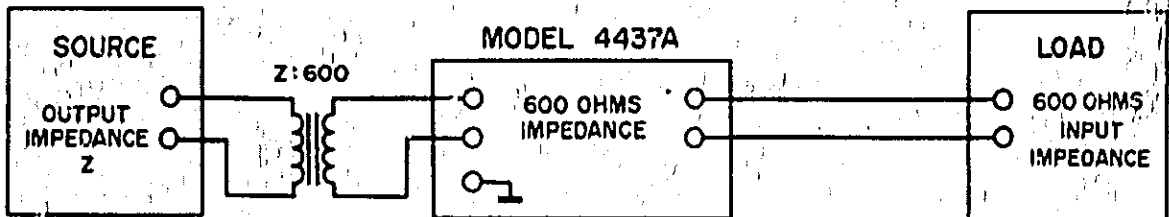

Figure 3-7. Input Matching with Transformer

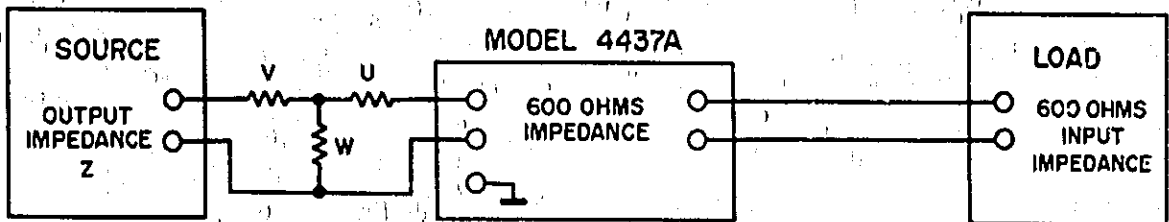

Figure 3-8. Input Matching with Resistive Network

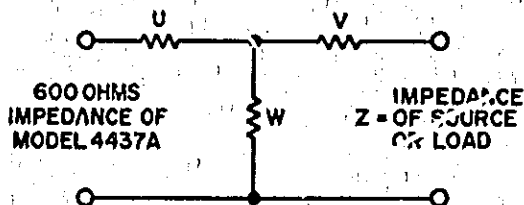

Figure 3-9. Resistive Matching Network

Table 3-1. Matching Network Values

Z (Ohms)	U (Ohms)	V (Ohms)	W (Ohms)	Insertion Loss
50	574.5	2.111	49.92	17dB
200	489.9	.9924	243.4	10dB
500	245.2	13.22	1148.0	4dB
2000	33.06	1874.0	670.8	11dB
5000	3.232	4690.0	636.2	15dB

b. Except for the condition stated in a., a resistive impedance-matching network or a matching transformer should be used. Impedance matching with matching transformer is shown in Figure 3-7. The transformer should possess good frequency characteristics in the range of frequencies to be used and proper input and output impedances equal to the source impedance and the impedance of the Model 4437A. Also, insertion loss of the transformer should be low. Impedance matching with a matching network is shown in Figure 3-8. Resistors used in the network should be deposited film or carbon type. Also, better accuracy is obtained if the network is enclosed in a shielded container and connecting leads are kept short. Data on impedance-

matching networks for the Model 4437A are given in Figure 3-9 and Table 3-1. Insertion loss values are included in Table 3-1.

3-22. **NEED FOR OUTPUT MATCHING.** To maintain the rated attenuation accuracy of the Model 4437A, the impedance of the load must match the output impedance of the Model 4437A. When the load must also be terminated in its matching impedance, a matching transformer or a resistive matching network should be used. When mismatch does not affect the load, the required impedance match for the Model 4437A can under some conditions, be obtained by use of a single resistor. Conditions under which a resistor can be used, and use of matching transformers and matching networks, are discussed below.

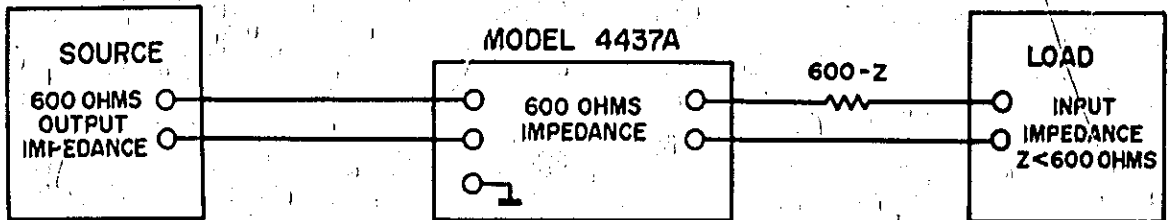

Figure 3-10. Simple Output Matching with Series Resistor

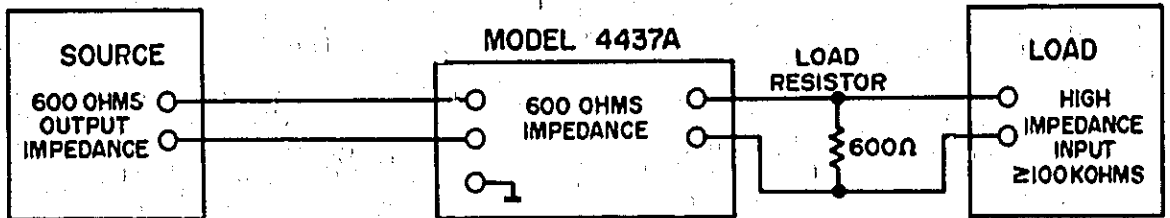

Figure 3-11. Output Matching with Shunt Resistor

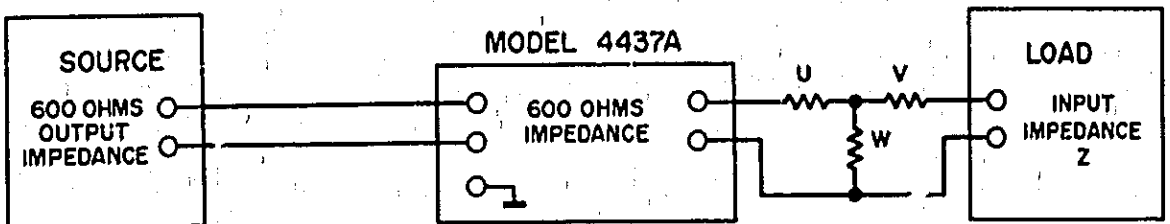

Figure 3-12. Output Matching with Resistive Network

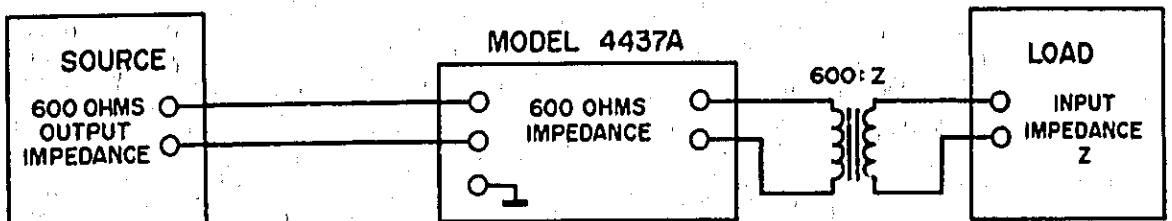

Figure 3-13. Output Matching with Transformer

3-23. MATCHING AT THE OUTPUT

a. When the impedance of the load is lower than that of the Model 4437A and the load is not affected by mismatch, impedance match for the Model 4437A output can be obtained by inserting a series resistor between 4437A output and load as shown in Figure 3-10. Resistor value should be the difference between the Model 4437A output impedance and the load impedance.

b. When the impedance of the load is much higher than that of the Model 4437A, on the order of 100,000 ohms or more, impedance match for

the Model 4437A can be obtained by using a shunting resistor across the Model 4437A output as shown in Figure 3-11. For the Model 4437A, the shunting resistor should be 600 ohms.

c. Resistive matching networks or matching transformers may be used to provide the Model 4437A and its load with an impedance match. Figure 3-12 shows impedance matching with matching network and Figure 3-13 shows impedance matching with transformer. Network data and connections are given in Figure 3-9 and Table 3-1. Similarly in matching at the INPUT, the insertion loss of the resistive network or the transformer should be taken into account.

Table 3-2. Attenuation Factors

db	Attenuation Factor A_f	db	Attenuation Factor A_f	db	Attenuation Factor A_f
0	1.0000	40	.010000	80	.00010000
1	.8913	41	.008913	81	.00008913
2	.7943	42	.007943	82	.00007943
3	.7079	43	.007079	83	.00007079
4	.6310	44	.006310	84	.00006310
5	.5623	45	.005623	85	.00005623
6	.5012	46	.005012	86	.00005012
7	.4467	47	.004467	87	.00004467
8	.3981	48	.003981	88	.00003981
9	.3548	49	.003548	89	.00003548
10	.3162	50	.003162	90	.00003162
11	.2818	51	.002818	91	.00002818
12	.2512	52	.002512	92	.00002512
13	.2239	53	.002239	93	.00002239
14	.1995	54	.001995	94	.00001995
15	.1778	55	.001778	95	.00001778
16	.1585	56	.001585	96	.00001585
17	.1413	57	.001413	97	.00001413
18	.1259	58	.001259	98	.00001259
19	.1122	59	.001122	99	.00001122
20	.1000	60	.001000	100	.00001000
21	.08913	61	.0008913	101	.000008913
22	.07943	62	.0007943	102	.000007943
23	.07079	63	.0007079	103	.000007079
24	.06310	64	.0006310	104	.000006310
25	.05623	65	.0005623	105	.000005623
26	.05012	66	.0005012	106	.000005012
27	.04467	67	.0004467	107	.000004467
28	.03981	68	.0003981	108	.000003981
29	.03548	69	.0003548	109	.000003548
30	.03162	70	.0003162	110	.000003162
31	.02818	71	.0002818	111	.000002818
32	.02512	72	.0002512	112	.000002512
33	.02239	73	.0002239	113	.000002239
34	.01995	74	.0001995	114	.000001995
35	.01778	75	.0001778	115	.000001778
36	.01585	76	.0001585	116	.000001585
37	.01413	77	.0001413	117	.000001413
38	.01259	78	.0001259	118	.000001259
39	.01122	79	.0001122	119	.000001122
				120	.000001000

SECTION IV THEORY OF OPERATION

4-1. GENERAL

4-2. The Model 4437A is shown in simplified schematic form in Figure 4-1. In the complete schematic (Figure 5-2) note that each attenuator section, 0, 9dB, 9dB, and 110dB, is composed of four-segments; each basically has the same configuration as shown in Figure 4-1. T-type attenuation pads are used in 110dB and 9dB sections, and bridged-T type pads are used in 0, 9dB section. The attenuator circuit ground is isolated from the cabinet ground by capacitor C1, to allow a floating input, i. e., an ac signal at a dc level.

4-3. ATTENUATION EXPRESSED IN DECIBELS

4-4. POWER AND VOLTAGE RATIOS

4-5. The basic equation for computing attenuation in decibels is based on a power ratio where P = power, V = voltage, and R = resistance:

$$\text{Decibels} = 10 \log_{10} \left(\frac{P_1}{P_2} \right) \quad (1)$$

Since power is expressed as: $P = \frac{V^2}{R}$ (2)

Equation (1) may be written as:

$$\text{Then dB} = 10 \log_{10} \left(\frac{\frac{V_1^2}{R_1}}{\frac{V_2^2}{R_2}} \right) \quad (3)$$

and if $R_1 = R_2$

$$\text{Then dB} = 10 \log_{10} \left(\frac{V_1}{V_2} \right)^2 \quad (4)$$

The basic rules for exponents of logarithms then allow equation (4) to be written as:

$$\text{dB} = 20 \log_{10} \left(\frac{V_1}{V_2} \right) \quad (5)$$

4-6. The values for A_f (attenuation factor) given in Table 3-2 are based on a voltage ratio which assume that the resistance at the input and output is the same. Values for A_f are computed using equation (5) where $V_1 = V_{in}$ and $V_2 = V_{out}$:

$$V_{out} = V_{in} A_f \text{ or } \frac{V_{in}}{V_{out}} = \frac{1}{A_f} \quad (6)$$

Then, substituting equation (6) in equation (5) gives

$$\text{dB} = 20 \log_{10} \left(\frac{1}{A_f} \right) \quad (7)$$

Solving for A_f gives

$$A_f = \frac{1}{\text{antilog}_{10} \frac{\text{number of dB}}{20}} \quad (8)$$

An example will check the value for A_f given in Table 3-2 for 24dB:

$$A_f = \frac{1}{\text{antilog}_{10} \left(\frac{24}{20} \right)} = \frac{1}{\text{antilog}_{10}(1.2)} \quad (9)$$

From a log table, the antilog_{10} of 1.2 is 15.85 and

$$A_f = \frac{1}{15.85} = 0.0631 \quad (10)$$

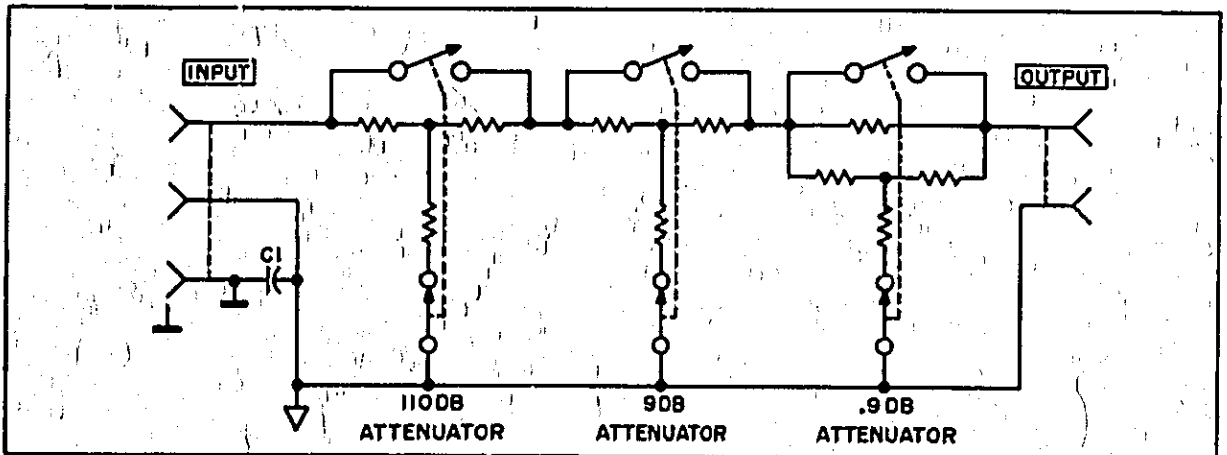

Figure 4-1. Model 4437A Simplified Circuit

4-7. REFERENCE to dB

4-8. The dB levels given in Figure 3-3 are referenced to a milliwatt of power, hence the term dBm. This indicates that the logarithm is taken of a power ratio where 1 milliwatt is the reference. For the 30dBm shown in Figure 3-3A, equation (1) and (2) show that:

$$\begin{aligned} \text{dBm} &= 10 \log_{10} \frac{(24.5)^2}{600} \text{ milliwatt} = 10 \log_{10}(1090) \\ &= 10(3) = 30 \end{aligned}$$

MAINTENANCE

SECTION V MAINTENANCE

5-1. INTRODUCTION

5-2. Maintenance of the Model 4437A should be minimal unless an overload voltage or physical damage requires replacement of a part. This section gives maintenance and service information. Included is a table of recommended test equipment, repair procedures, and an in-cabinet performance check.

5-3. TEST EQUIPMENT

5-4. Table 5-1 lists recommended equipment for maintaining and checking performance of instrument. Test equipment having equivalent characteristics may be substituted for equipment listed.

5-5. RESISTANCE MEASUREMENTS

5-6. If overload power has been applied and damage to the instrument is suspected, make dc resistance measurements as follows:

- a. Terminate the OUTPUT terminals with 600 ohms $\pm 0.5\%$.
- b. Connect a resistance measuring device (HP 3480A/B with 3484A Option 042) to the INPUT terminals and measure the dc resistance at each step of each decade. Resistance measured should be 600 ohms $\pm 0.5\%$.
- c. If the reading on any step is not within specified limit, the instrument has been damaged.

5-7. IN-CABINET PERFORMANCE CHECK

5-8. GENERAL

5-9. The performance check can be used to verify proper operation of the instrument and also may be used:

- a. As part of an incoming inspection check of instrument specifications.
- b. Periodically, for instruments used in systems where maximum reliability is important.
- c. As part of a procedure to locate defective components.
- d. After any repair or adjustment before returning instrument to regular service.
- e. As a permanent record of instrument maintenance performed.

5-10. AC PERFORMANCE TEST

5-11. The ac performance test setup is illustrated in Figure 5-1. An Oscillator (HP Model 4204A), an AC Voltmeter (HP Model 400E/EL or 400F/FL), and a battery operated AC Voltmeter (HP Model 400FL with external batteries) are required for this test. In addition, one 600-ohm 2-watt resistor is required. This resistor must be enclosed in a shield as shown in Figure 5-1. The range-to-range accuracy of the

Table 5-1. Test Equipment Required

Instrument Type	Required Characteristics	Use	Recommended Model
Digital Ohmmeter	Range: 1,000 Ω , 1 range Accuracy: better than $\pm 0.05\%$.	Resistance Measurement	HP Model 3480A/B with 3484A Option 042 Digital Voltmeter
Oscillator	Output Frequency: 100kHz and 1MHz. Output Voltage: 10V into 600 Ω .	AC Performance Test	HP Model 4204A Oscillator
AC Voltmeter	Frequency Range: 100kHz to 1MHz. Range: +20dB, 1 range Accuracy: $\pm 1\%$ of full scale	AC Performance Test	HP Model 400E/EL or 400F/FL AC Voltmeter
Battery Operated AC Voltmeter	Frequency Range: 100kHz to 1MHz. Ranges: +20dB to -60dB, 9 ranges. Accuracy: $\pm 1\%$ of reading (Para: 5-11).	AC Performance Test	HP Model 400FL AC Voltmeter with external batteries
Milliohmmeter	Ranges: 3m Ω -100 Ω Accuracy: $\pm 2\%$ of Range	Troubleshooting	HP Model 4328A Milliohmmeter

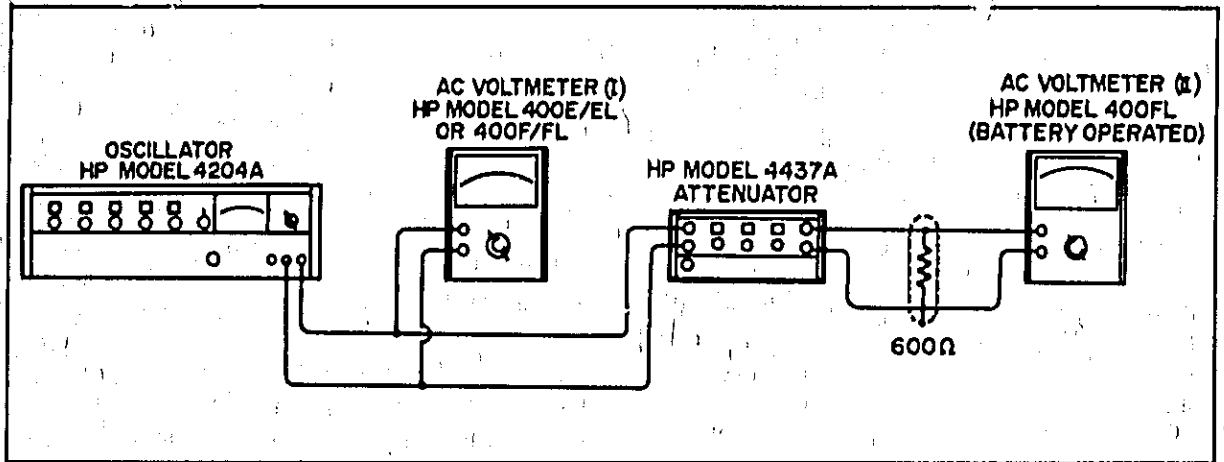

Figure 5-1. AC Performance Test Setup

battery operated AC Voltmeter (HP Model 400FL) from +20dB to -60dB must be known to within 0.1dB at 100 kHz and 1MHz. Any errors should be algebraically subtracted from the error found during the performance test.

5-12. To perform the ac performance test, proceed as follows:

- a. Arrange test setup as illustrated in Figure 5-1 and see paragraph 3-9.
- b. Set controls as indicated in Step 1 of Table 5-2.
- c. Adjust Oscillator AMPLITUDE control for convenient reference on AC Voltmeter II connected to 4437A OUTPUT terminals.

CAUTION

DO NOT APPLY MORE THAN 1 WATT MAXIMUM (24.5V rms) TO MODEL 4437A INPUT TERMINALS TO PREVENT ATTENUATOR BURN-OUT.

- d. Monitor input signal amplitude using the AC Voltmeter I connected to 4437A INPUT terminals and note its indication.
- e. Set controls as indicated in Step 2 of Table 5-2, and maintain same input signal amplitude as in Step d. using Oscillator AMPLITUDE control. Check that AC Voltmeter II indicates same as reference tolerance listed in Table 5-2.
- f. Repeat Step e. for Steps 3 thru 9 of Table 5-2.
- g. The attenuation errors from 60dB to 110dB are calculated by combining the errors of previous readings, as follows:

Table 5-2. AC Performance Test A

Step	Oscillator Frequency	4437A DB Setting	AC Voltmeter DB Range	Tolerance in DB
1	100kHz	0	+20	
2	100kHz	10	+10	±0.1
3	100kHz	20	0	±0.1
4	100kHz	30	-10	±0.1
5	100kHz	40	-20	±0.1
6	100kHz	50	-30	±0.1
7	100kHz	60	-40	±0.1
8	100kHz	70	-50	±0.1
9	100kHz	80	-60	±0.1
10	1MHz	0	+20	
11	1MHz	10	+10	±0.2
12	1MHz	20	0	±0.2
13	1MHz	30	-10	±0.2
14	1MHz	40	-20	±0.2
15	1MHz	50	-30	±0.2
16	1MHz	60	-40	±0.2
17	1MHz	70	-50	±0.3
18	1MHz	80	-60	±0.3

4437A DB Setting	Calculation	Tolerance in DB
80	Add 80dB and 10dB errors	±0.1
100	Add 80dB and 20dB errors	±0.2
110	Add 80dB and 30dB errors	±0.2

- h. Set controls as indicated in Step 10 of Table 5-2.
- i. Adjust Oscillator AMPLITUDE control for convenient reference as indicated on AC Voltmeter II.
- j. Monitor input signal amplitude using AC Voltmeter I and note its indication.
- k. Set controls as indicated in Step 11 of Table 5-2 and maintain same input signal amplitude as in Step j. using Oscillator AMPLITUDE control. Check that AC Voltmeter II indicates same as reference tolerance listed in Table 5-2.
- l. Repeat Step k. for Step 12 thru 18 of Table 5-2.

Table 5-3. AC Performance Test B

Step	Oscillator Frequency	4437A DB Setting	AC Voltmeter DB Range	Tolerance in DB
1	100kHz	0	+20	
2	100kHz	50	-30	±0.1
3	100kHz	51	-30	±0.1
4	100kHz	52	-30	±0.1
5	100kHz	53	-30	±0.1
6	100kHz	54	-30	±0.1
7	100kHz	55	-30	±0.1
8	100kHz	56	-30	±0.1
9	100kHz	57	-30	±0.1
10	100kHz	58	-30	±0.1
11	100kHz	59	-30	±0.1
12	100kHz	59.1	-30	±0.1
13	100kHz	59.2	-30	±0.1
14	100kHz	59.3	-30	±0.1
15	100kHz	59.4	-30	±0.1
16	100kHz	59.5	-30	±0.1
17	100kHz	59.6	-30	±0.1
18	100kHz	59.7	-30	±0.1
19	100kHz	59.8	-30	±0.1
20	100kHz	59.9	-30	±0.1

Table 5-4. AC Performance Test C

Step	Oscillator Frequency	4437A DB Setting	AC Voltmeter DB Range	Tolerance in DB
1	1MHz	0	+20	
2	1MHz	50	-30	±0.2
3	1MHz	51	-30	±0.2
4	1MHz	52	-30	±0.2
5	1MHz	53	-30	±0.2
6	1MHz	54	-30	±0.2
7	1MHz	55	-30	±0.2
8	1MHz	56	-30	±0.2
9	1MHz	57	-30	±0.2
10	1MHz	58	-30	±0.2
11	1MHz	59	-30	±0.2
12	1MHz	59.1	-30	±0.2
13	1MHz	59.2	-30	±0.2
14	1MHz	59.3	-30	±0.2
15	1MHz	59.4	-30	±0.2
16	1MHz	59.5	-30	±0.2
17	1MHz	59.6	-30	±0.2
18	1MHz	59.7	-30	±0.2
19	1MHz	59.8	-30	±0.2
20	1MHz	59.9	-30	±0.2

m. The attenuation errors from 90dB to 110dB are calculated by combining the errors of previous readings, as follows:

4437A DB Setting	Calculation	Tolerance in DB
90	Add 80dB and 10dB errors	±0.3
100	Add 80dB and 20dB errors	±0.5
110	Add 80dB and 30dB errors	±0.5

- n. Set controls as indicated in Step 1 of Table 5-3.
- o. Adjust Oscillator AMPLITUDE control so that AC Voltmeter II indicates 0dB.
- p. Monitor input signal amplitude using AC Voltmeter I and note its indication.
- q. Set controls as indicated in Step 2 of Table 5-3, and maintain same input signal amplitude as in Step p. using Oscillator AMPLITUDE controls. Check that AC Voltmeter II indicates same as reference (0dB) ± tolerance listed in Table 5-3.
- r. Change 4437A attenuation to 59dB in 1dB steps (Steps 3 thru 11) maintaining same input signal amplitude as in Step p. using Oscillator AMPLITUDE control (if necessary), and check that AC Voltmeter II indicates 1dB change for each step. The AC Voltmeter II should indicate within tolerance listed in Table 5-3.
- s. Change 4437A attenuation to 59.9dB in 0.1dB steps (Steps 12 thru 20) maintaining same input signal amplitude as in Step p. using Oscillator AMPLITUDE control (if necessary), and check that AC Voltmeter II indicates 0.1dB change for each step. The AC Voltmeter II should indicate within the tolerances listed in Table 5-3.

t. Repeat Steps n. thru s. at frequency of 1MHz. Applicable tolerances at 1MHz are listed in Table 5-4.

5-13. Great care must be exercised in the shielding of the test setup in order to carry out the ac performance test above 80dB directly. Also, an RF Amplifier should be used to increase the 4437A input power to +30dBm. Coaxial cable with an outer-shield must be used between the RF Amplifier and the 4437A. One end of the outer-shield of the cable must be disconnected from the connector to prevent RF current flow in the outer-shield conductor. Spurious signals picked up by the AC Voltmeter II can obscure the correct indication and show up as inconsistencies between readings on repeat measurements. With adequate shielding of every part of the measurement setup, AC Voltmeter II indications become stable. To check at 110dB and above a battery-operated ac voltmeter which is more sensitive and accurate than the 400FL, is required.

5-14. COVER REMOVAL

5-15. When it is necessary to perform preventive maintenance or to do repairs, the covers must be removed. Refer to following steps for cover removal:

- a. TOP and BOTTOM COVER - Remove the two screws at rear of top cover and slide covers to rear.
- b. SHIELD COVERS - Remove the screw at rear of cover and slide cover to rear.

5-16. COMPONENT REPLACEMENT

5-17. REPLACEMENT OF SPRING CONTACTS

5-18. Figure 8-1 identifies spring contact components. To replace spring contacts, proceed as follows:

- a. Remove all instrument covers.
- b. Remove the screw in molded rail.
- c. Carefully pull molded rail up while holding molded slide down.
- d. Push molded slide horizontally to remove.
- e. Unsolder the spring contact and remove.
- f. Clean gold plated contact using a Contact Bur-
nishing Tool (HP Part No. 8660-0083, see
Figure 5-2. ABRASIVE STICK).
- g. Solder a new spring contact in place and re-
install molded slide and rail.

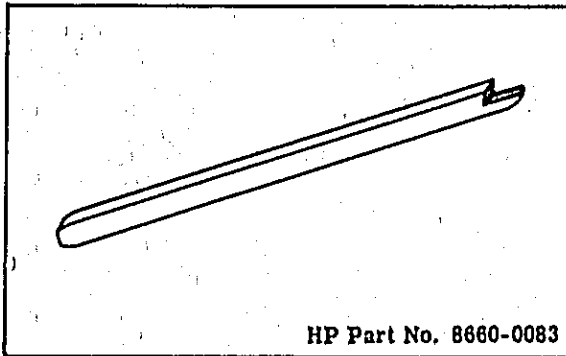

Figure 5-2. Abrasive Stick

5-19. REPLACEMENT OF MOLDED SLIDES

5-20. Figure 8-1 identifies the part numbers of molded slides. When a molded slide is ordered with part number 04437-5023, you will receive slide component shown in Figure 5-3 (a). This molded slide must be cut as illustrated 5-3 (b), or 5-3 (c), respectively, for the segment to be used.

5-21. REPLACEMENT OF RESISTORS

5-22. Figure 8-1 identifies the resistors on A1 Board Assembly P/N 04437-7721. Replacement resistors may be ordered from parts information in Section VI. When a resistor is replaced, no adjustment is required.

5-23. PREVENTIVE MAINTENANCE

5-24. Recommended preventive maintenance operations for the attenuator include cleaning, lubrication and electrical checks. These procedures insure proper attenuator operation. Generally, under normal use and conditions, preventive maintenance should be performed every nine to twelve months.

5-25. CLEANING

5-26. Cleaning routine should include the following:

- a. Remove all instrument covers.
- b. Remove the screw in the molded rail.

NOTE

Do not remove the four screws in molded rails for more than one attenuator decade digit at a time.

- c. Carefully pull molded rail up while holding molded slide down.
- d. Push molded slide horizontally and lift to remove.
- e. Clean contacts as shown in Figure 5-4, using ABRASIVE STICK (HP Part No. 8660-0083. See Figure 5-2).
- f. Replace the molded rail and slide. Repeat above steps for all contacts.

NOTE

S1 is shielded. Remove the screw to remove shield cover.

5-27. LUBRICATION

5-28. The cam assembly in the attenuator was lubricated at factory. Relubrication is required every twelve months. For Lubrication, use HP Part No. 6040-0018 or equivalent. Lubricate as follows:

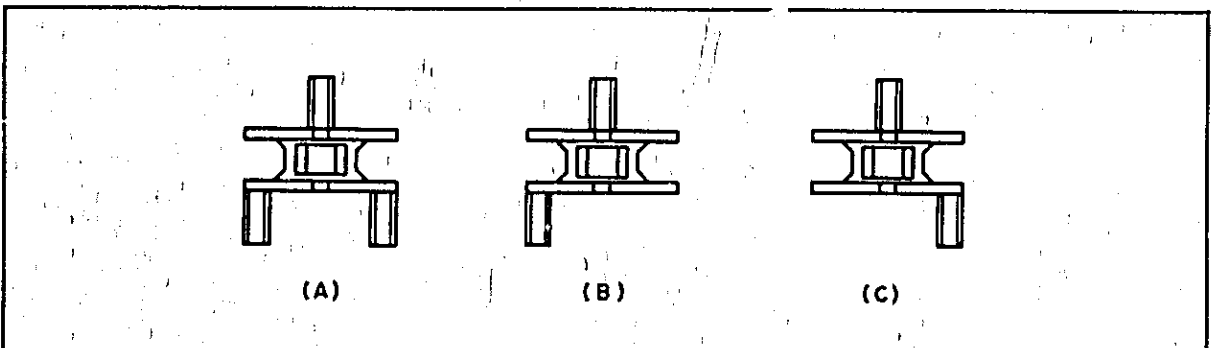

Figure 5-3. Molded Slide

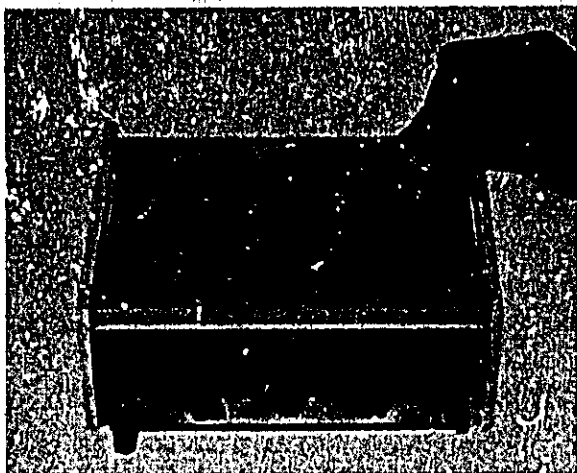

Figure 5-4. Contact Cleaning

- a. Remove top and bottom covers.
- b. Remove bottom shield cover.
- c. Lubricate all cam assemblies using HP Part No. 6040-0018.
- d. Replace all covers.

5-29. ELECTRICAL CHECK

5-30. The electrical checks required for the preventive maintenance program are the same as those listed for the performance checks (paragraphs 5-7 through 5-13). Perform these checks for every twelve months of attenuator operation. A record of the results of the checks will provide data history which could prove valuable if troubleshooting is ever necessary.

5-31. TROUBLESHOOTING

5-32. Use the simplified diagram Figure 4-1 and schematic diagram Figure 8-5 to determine the section of instrument in which trouble is located. Figure 8-1 shows physical location of components (cover removed). Give instrument a thorough visual check. Look for loose connections, burned or loose components or any other condition which suggests a probable trouble location. The following paragraphs list procedure for specific troubles.

5-33. CONTACT RESISTANCE CHECK FOR SWITCHES

5-34. The purpose of this check is to verify proper operation of attenuator switches by using the HP Model 4328A Milliohmmeter. Proceed as follows:

- a. Remove all instrument covers.
- b. Set the 4437A controls to 00.0dB.
- c. Connect the Model 4328A to upper terminals at INPUT and OUTPUT as shown in Figure 5-5 using 16005A Clip-Type probes.

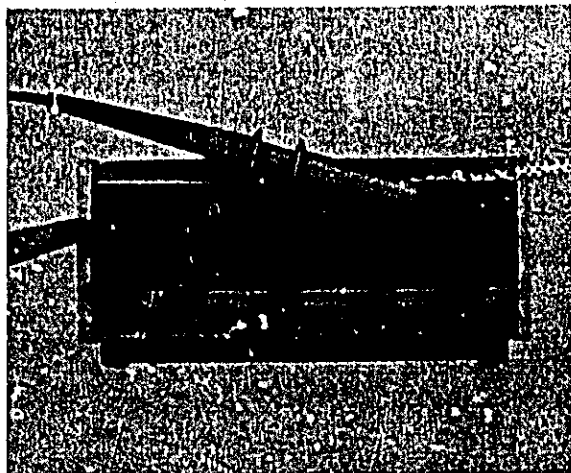

Figure 5-5. Contact Resistance Check (I)

- d. The 4328A reading should be less than 4.0Ω . If not, gently press down spring contacts (which meet the gold plated contacts) with a plastic stick to isolate the contact which has the higher contact resistance. Then clean contact as described in paragraph 5-26.
- e. Connect the Model 4328A to middle terminal at INPUT (J2) and lower terminal at OUTPUT (J5).
- f. The 4328A reading should be less than $200m\Omega$. If not, check cable connections between J2 and ALJ1 and between J5 and ALJ2.
- g. Set the 4437A controls to 119.9dB and connect Model 4328A between lower terminal at OUTPUT and switch side of resistors (R3, R6, R9, R12, R15, R18, R21, R24, R28, R32, R36, and R40). See Figure 5-6.

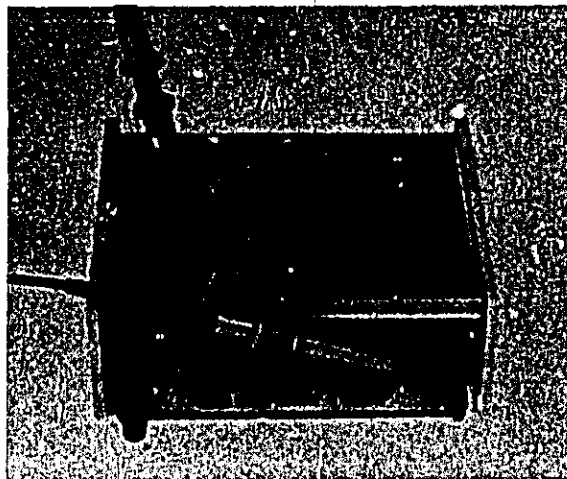

Figure 5-6. Contact Resistance Check (II)

- h. The reading of the 4328A for each contact is shown in Table 5-5. The values shown in Table 5-5 are typical and tolerance should be $\pm 30\%$ of the value. If the 4328A reading is more than $+30\%$ of the value, press the spring contact gently using a plastic stick. If reading goes down, clean the contact or replace the spring contact.

Table 5-5. Resistance between OUTPUT and Switch Resistors

Resistor	Readings
R3	130m Ω
R6	130m Ω
R9	130m Ω
R12	130m Ω
R15	100m Ω
R18	80m Ω
R21	60m Ω
R24	40m Ω
R28	30m Ω
R32	20m Ω
R36	20m Ω
R40	20m Ω

PARTS LIST

SECTION VI REPLACEABLE PARTS

6-1. INTRODUCTION

6-2. This section contains information for ordering replacement parts. Table 6-2 lists parts in alphabetical order of their reference designators and indicates the description (see Table 6-1 for abbreviations used) and HP part number of each part together with any applicable notes.

6-3. Miscellaneous parts associated with each assembly are listed at the end of each assembly listing. Others are listed at the end of Table 6-2.

6-4. ORDERING INFORMATION

6-5. To obtain replacement parts, address order or inquiry to your local Hewlett-Packard Field Office (see lists at rear of this manual for addresses). Identify parts by their Hewlett-Packard part numbers.

6-6. To obtain a part that is not listed, include:

- a. Instrument model number.
- b. Instrument serial number.
- c. Description of the part.
- d. Function and location of the part.

REFERENCE DESIGNATORS			
<p>A = assembly</p> <p>B = motor</p> <p>BT = battery</p> <p>C = capacitor</p> <p>CP = coupler</p> <p>CR = diode</p> <p>DL = delay line</p> <p>DS = device signaling (lamp)</p>	<p>E = misc electronic part</p> <p>F = fuse</p> <p>FL = filter</p> <p>J = jack</p> <p>K = relay</p> <p>L = inductor</p> <p>M = meter</p> <p>MP = mechanical part</p>	<p>P = plug</p> <p>Q = transistor</p> <p>R = resistor</p> <p>RT = thermistor</p> <p>S = switch</p> <p>T = transformer</p> <p>TB = terminal board</p> <p>TP = test point</p>	<p>V = vacuum tube, neon bulb, phototell, etc.</p> <p>VR = voltage regulator</p> <p>W = cable</p> <p>X = socket</p> <p>Y = crystal</p>
ABBREVIATIONS			
<p>A = amperes</p> <p>A. F. C. = automatic frequency control</p> <p>AMPL = amplifier</p> <p>B. F. O. = beat frequency oscillator</p> <p>BK CU = beryllium copper</p> <p>BH = binder head</p> <p>BP = bandpass</p> <p>BR = brass</p> <p>BWO = backward wave oscillator</p>	<p>H = hermes</p> <p>HEX = hexagonal</p> <p>HG = mercury</p> <p>HR = hour(s)</p> <p>IF = intermediate freq</p> <p>IMPG = impregnated</p> <p>INCD = incandescent</p> <p>INCL = include(s)</p> <p>INS = insulation(ed)</p> <p>INT = internal</p>	<p>NFN = negative-positive-negative</p> <p>NRFR = not recommended for field replacement</p> <p>NSR = not separately replaceable</p> <p>OBD = order by description</p> <p>OH = oval head</p> <p>OX = oxide</p>	<p>RMS = root-mean square</p> <p>RWV = reverse working voltage</p> <p>S-B = slow-blow</p> <p>SCR = screw</p> <p>SE = selenium</p> <p>SECT = section(s)</p> <p>SEMICON = semiconductor</p> <p>SI = silicon</p> <p>SIL = silver</p> <p>SL = slide</p> <p>SFD = spring</p> <p>SPL = special</p> <p>SST = stainless steel</p> <p>SR = split ring</p> <p>STL = steel</p>
<p>CCW = counter-clockwise</p> <p>CER = ceramic</p> <p>CMO = cabinet mount only</p> <p>COEF = coefficient</p> <p>COM = common</p> <p>COMP = composition</p> <p>COMPL = complete</p> <p>CONN = connector</p> <p>CP = cadmium plate</p> <p>CRT = cathode-ray tube</p> <p>CW = clockwise</p>	<p>K = kilo = 1000</p> <p>LH = left hand</p> <p>LIN = linear taper</p> <p>LK WASH = lock washer</p> <p>LOG = logarithmic taper</p> <p>LPF = low pass filter</p> <p>M = milli = 10⁻³</p> <p>MEG = meg = 10⁶</p> <p>MET FLM = metal film</p> <p>MET OX = metallic oxide</p> <p>MFR = manufacturer</p> <p>MINAT = miniature</p> <p>MOM = momentary</p> <p>MTG = mounting</p> <p>MY = "mylar"</p>	<p>P = peak</p> <p>PC = printed circuit</p> <p>PF = picofarads = 10⁻¹² farads</p> <p>PH BRZ = phosphor bronze</p> <p>PHL = Phillips</p> <p>PIV = peak inverse voltage</p> <p>PNP = positive-negative-positive</p> <p>P/O = per of</p> <p>POLY = polystyrene</p> <p>PORC = porcelain</p> <p>POS = position(s)</p> <p>POT = potentiometer</p> <p>PP = peak-to-peak</p> <p>PT = point</p> <p>PWV = peak working voltage</p>	<p>TA = tantalum</p> <p>TD = time delay</p> <p>TGL = toggle</p> <p>THD = thread</p> <p>TI = titanium</p> <p>TOL = tolerance</p> <p>TRIM = trimmer</p> <p>TWT = traveling wave tube</p> <p>U = micro = 10⁻⁶</p> <p>VAR = variable</p> <p>VDCW = dc working volts</p> <p>W/ = with</p> <p>W = watts</p> <p>WIV = working inverse voltage</p> <p>WW = wirewound</p> <p>W/O = without</p>
<p>F = farads</p> <p>FR = flat head</p> <p>FIL H = filament head</p> <p>FXD = fixed</p> <p>GE = germanium</p> <p>GL = glass</p> <p>GRD = ground(ed)</p>	<p>N = nano (10⁻⁹)</p> <p>N/C = normally closed</p> <p>NE = neon</p> <p>NI PL = nickel plate</p> <p>N/O = normally open</p> <p>NPO = negative positive zero (zero temperature coefficient)</p>	<p>RECT = rectifier</p> <p>RF = radio frequency</p> <p>RH = round head or right hand</p> <p>RMO = rack mount only</p>	

Table 6-1. List of Reference Designators and Abbreviations

Table 6-2. Replaceable Parts

Ref. Desig.	HP Part No.	Description	Note
A1	04437-7721 04437-8721	BOARD ASS'Y BOARD:BLANK P. C.	
A1J1	1250-0257	CONNECTOR:RF FEMALE	
A1J2	1250-0257	CONNECTOR:RF FEMALE	
A1L1	9100-1621	INDUCTOR: FXD 18 μ H	
A1R1	0698-2054	R:FXD MET FLM 1176, 22 Ω 0.1% 1/2W	
A1R2	0698-2054	R:FXD MET FLM 1176, 22 Ω 0.1% 1/2W	
A1R3	0698-7383	R:FXD MET FLM 12.0 Ω 0.5% 1/8W	
A1R4	0698-2053	R:FXD MET FLM 588, 11 Ω 0.1% 1/2W	
A1R5	0698-2051	R:FXD MET FLM 311, 69 Ω 0.1% 1/2W	
A1R6	0698-2048	R:FXD MET FLM 421, 6 Ω 0.25% 1/4W	
A1R7	0698-2051	R:FXD MET FLM 311, 69 Ω 0.1% 1/2W	
A1R8	0698-2052	R:FXD MET FLM 490, 90 Ω 0.1% 1/2W	
A1R9	0698-2047	R:FXD MET FLM 121, 2 Ω 0.25% 1/8W	
A1R10	0698-2052	R:FXD MET FLM 490, 90 Ω 0.1% 1/2W	
A1R11	0698-2053	R:FXD MET FLM 588, 11 Ω 0.1% 1/2W	
A1R12	0698-7383	R:FXD MET FLM 12.0 Ω 0.5% 1/8W	
A1R13	0698-2053	R:FXD MET FLM 588, 11 Ω 0.1% 1/2W	
A1R14	0698-2046	R:FXD MET FLM 102, 6 Ω 0.25% 1/2W	
A1R15	0698-2040	R:FXD MET FLM 1703 Ω 0.25% 1/2W	
A1R16	0698-2046	R:FXD MET FLM 102, 6 Ω 0.25% 1/2W	
A1R17	0698-2045	R:FXD MET FLM 68, 77 Ω 0.25% 1/2W	
A1R18	0698-2050	R:FXD MET FLM 2583 Ω 0.25% 1/2W	
A1R19	0698-2045	R:FXD MET FLM 68, 77 Ω 0.25% 1/2W	
A1R20	0698-2043	R:FXD MET FLM 34, 5 Ω 0.5% 1/2W	
A1R21	0698-2044	R:FXD MET FLM 5200 Ω 0.5% 1/4W	
A1R22	0698-2043	R:FXD MET FLM 34, 5 Ω 0.5% 1/2W	
A1R23	0698-2046	R:FXD MET FLM 102, 6 Ω 0.25% 1/2W	
A1R24	0698-2049	R:FXD MET FLM 1703 Ω 0.25% 1/2W	
A1R25	0698-2046	R:FXD MET FLM 102, 6 Ω 0.25% 1/2W	
A1R26	0698-1105	R:FXD MET FLM 13, 3 Ω 1% 1/4W	
A1R27	0757-0401	R:FXD MET FLM 100 Ω 1% 1/8W	
A1R28	0698-4482	R:FXD MET FLM 17, 4k Ω 1% 1/8W	
A1R29	0698-4105	R:FXD MET FLM 13, 3 Ω 1% 1/4W	
A1R30	0757-0378	R:FXD MET FLM 11 Ω 1% 1/8W	
A1R31	0757-0489	R:FXD MET FLM 10 Ω 1% 1/4W	
A1R32	0757-0272	R:FXD MET FLM 52, 5k Ω 1% 1/8W	
A1R33	0757-0378	R:FXD MET FLM 11 Ω 1% 1/8W	
A1R34	0757-0378	R:FXD MET FLM 11 Ω 1% 1/8W	
A1R35	0698-3435	R:FXD MET FLM 38, 3 Ω 1% 1/8W	
A1R36	0698-3159	R:FXD MET FLM 26, 1 Ω 1% 1/8W	
A1R37	0757-0378	R:FXD MET FLM 11 Ω 1% 1/8W	
A1R38	0698-4105	R:FXD MET FLM 13, 3 Ω 1% 1/4W	
A1R39	0757-0401	R:FXD MET FLM 100 Ω 1% 1/8W	
A1R40	0698-4482	R:FXD MET FLM 17, 4k Ω 1% 1/8W	
A1R41	0698-4105	R:FXD MET FLM 13, 3 Ω 1% 1/4W	

See list of abbreviations in introduction to this section

Table 6-2, Replaceable Parts (Cont'd)

Ref. Desig.	HP Part No.	Description	Note
A1S1	04437-5022	SWITCH:P. C. BOARD NSR PART OF P. C. BOARD	
	04437-5023	RAIL:MOLDED 4 REQ'D	
	04437-5025	SLIDE:MOLDED 4 REQ'D	
	1460-0313	ARM:MOLDED	
A1S2	04437-5022	CONTACT:SPRING 8 REQ'D	
	04437-5023	SWITCH:P. C. BOARD NSR PART OF P. C. BOARD	
	04437-5025	RAIL:MOLDED 4 REQ'D	
	1460-0313	SLIDE:MOLDED 4 REQ'D	
A1S3	04437-5022	ARM:MOLDED	
	04437-5023	CONTACT:SPRING 8 REQ'D	
	04437-5025	SWITCH:P. C. BOARD NSR PART OF P. C. BOARD	
	1460-0313	RAIL:MOLDED 4 REQ'D	
C1	0160-0013	SLIDE:MOLDED 4 REQ'D	
J1	1510-0028	C:FXD MY 0.1 μ F 10% 400VDCW	
	04437-40001	CONNECTOR:BINDING POST RED	
	04437-5029	INSULATOR:BINDING POST FRONT	
	04437-3027	INSULATOR:BINDING POST REAR FOR J1 AND J2	
	04437-5030	BUSH:BINDING POST	
J2	04437-3029	INSULATOR BINDING POST SHAFT	
	1510-0057	SCREW BINDING POST	
J3	04437-40001	CONNECTOR:BINDING POST RED	
	04437-3028	INSULATOR:BINDING POST FRONT	
J4	1510-0087	SCREW BINDING POST	
	04437-40001	CONNECTOR:BINDING POST BLACK	
J5	1510-0056	INSULATOR:BINDING POST FRONT	
	04437-40001	CONNECTOR:BINDING POST RED	
	04437-5029	INSULATOR BINDING POST FRONT	
	04437-3027	INSULATOR BINDING POST REAR FOR J4 AND J5	
	04437-5030	BUSH:BINDING POST	
L1	04437-3028	INSULATOR:BINDING POST SHAFT	
	1510-0084	SCREW BINDING POST	
	04437-40001	CONNECTOR:BINDING POST RED	
L2	04437-3028	INSULATOR:BINDING POST FRONT	
	04437-3028	SCREW BINDING POST	
P1	9140-0114	INDUCTOR FXD 10 μ H	
P2	9140-0114	INDUCTOR FXD 10 μ H	
W1	1250-0172	CONNECTOR:RF MALE PART OF W1	
	1250-0172	CONNECTOR:RF MALE PART OF W2	
W2	04437-7202	CABLE ASSY:INCLUDING P1	
	04437-7201	CABLE ASSY:INCLUDING P2	

See list of abbreviations in Introduction to this section

Table 6-2, Replaceable Parts (Cont'd)

Ref. Desig.	HP Part No.	Description	Note
		MISCELLANEOUS	
	04437-1129 5040-3316 04437-1127 04437-1128 5000-4197	PANEL:FRONT FRAME:SIDE 2 REQ'D COVER ASS'Y:TOP COVER:BOTTOM COVER:SIDE 2 REQ'D	
	04437-3130 5060-0728 0370-0025 04437-5124 04440-5124	TRIM:FRONT PANEL 2 REQ'D FOOT ASS'Y:HALF MOD 2 REQ'D KNOB:ROUND 3 REQ'D DIAL:MARKED "0 TO 11" DIAL:MARKED "0 TO 9" 2 REQ'D	
	04437-1022	CHASSIS:FRONT	
	04437-1024 04437-1025 04437-7024	COVER:SHIELD BOTTOM COVER:SHIELD TOP COVER ASS'Y:SHIELD A1 BOARD	
	04437-1030 04437-1031	ANGLE:L ANGLE:L	
	04437-1033 04437-1034	COVER:SHIELD FOR J4 AND J5 FRONT COVER:SHIELD FOR J1 AND J2 FRONT	
	04437-1035 04437-1036 1460-0314 04437-7023 04437-3021	COVER:SHIELD FOR J4 AND J5 REAR COVER:SHIELD FOR J1 AND J2 REAR SPRING:WIRE 3 REQ'D CLICK ARM ASS'Y:DIAL 3 REQ'D SHAFT:CAM 3 REQ'D	
	04437-3022 04437-3024 04437-5021 04437-5026 04437-5027	STUD:ARM 3 REQ'D STUD:SPRING 3 REQ'D ARM:MOLDED 12 REQ'D CAM:10 POSITION 2 REQ'D CAM:12 POSITION	
	04437-5031 04440-1038 04437-1037 04437-1038 04437-1039 04437-1040	BUSH:CAM SHAFT 6 REQ'D SPRING:L. 2 REQ'D INSULATOR ANGLE INSULATOR, 2 REQ'D CHASSIS:MAIN	

See list of abbreviations in introduction to this section

**BACK DATING
MANUAL
CHANGES**

SECTION VII MANUAL CHANGES AND OPTIONS

7-1. OPTIONS

7-2. Options are standard modifications performed on HP instruments at the factory. No options for the Model 4437A are offered at the present time.

7-3. SPECIAL INSTRUMENTS

7-4. "Specials" are standard HP instruments that are modified according to customer specifications. A separate insert sheet is included with the manual for special instruments having electrical changes. Make the changes specified in addition to any other changes that are necessary.

7-5. MANUAL CHANGES

7-6. This manual applies directly to the Model 4437A with serials prefixed 1201/1202. The following paragraph explains how to adapt this manual to apply to later instruments with higher serial prefix. Technical corrections to this manual (if any) are called errata and are listed on a separate "Manual Changes" sheet supplied with this manual.

7-7. LATER INSTRUMENTS: If the serial prefix of your Model 4437A is above 1201/1202, refer to a separate "Manual Changes" sheet supplied with this

manual. Locate the serial prefix of your instrument and make the indicated changes.

7-8. EARLIER INSTRUMENTS (Backdating Changes): If the serial prefix of your Model 4437A is below 1201/1202, refer to Table 7-1 for the changes necessary to adapt this manual to your particular instrument. Locate the serial prefix of number of your instrument in the table and make the indicated changes. Note that instrument component values that differ from those in this manual, yet are not listed in this backdating changes, should be replaced using the part number given in this manual.

Table 7-1. Backdating Changes.

Instrument Serial Prefix	Make Changes
1039/1040	1, 2, 3, 4
1202J-00215 and below	2, 3, 4
1250J-00245 and below	3, 4
1250J-00685 and below	4

CHANGE 1

Page 6-4, Table 6-2. Replaceable Parts, Miscellaneous,
 Change HP Part No. of PANEL:FRONT HP to 04437-1020
 Change HP Part No. of PANEL:FRONT YHP to 04437-1021
 Change HP Part No. of FRAME:SIDE to 5040-3310
 Change HP Part No. of COVER ASS'Y:TOP to 04437-1027
 Change HP Part No. of COVER:BOTTOM to 04437-1028
 Change HP Part No. of COVER:SIDE to 04440-1031
 Change HP Part No. of TRIM:FRONT PANEL to 04437-3030
 Change HP Part No. of DIAL:MARKED "0 TO 11" to 04437-5024
 Change HP Part No. of DIAL:MARKED "0 TO 9" to 04440-5024

CHANGE 2

Page 6-4, Table 6-2. Replaceable Parts, Miscellaneous,
 Change HP Part No. of KN:JB:ROUND 3 REQ'D to 0370-0310

CHANGE 3

In the Table 6-2, Replaceable Parts, delete following parts:

Page 6-2: A1
 Page 6-3: L1 and L2

Page 8-3, Figure 8-4, delete following (replace them with mere straight line indicating short):

A1L1: 18 μ H shown at the lower left corner of A1 (grey area).
 L1: 10 μ H shown between J1 and P1 at the upper left corner.
 L2: 10 μ H shown between J4 and P2 at the lower right corner.

Page 6-5, Paragraph 6-34, step d procedure,
Partially change step d description as follows:
d. The 4328A reading should be less than $300m\Omega$.

Page 6-2, Figure 8-1, Board Assembly;
Change Figure 8-1 as shown below:

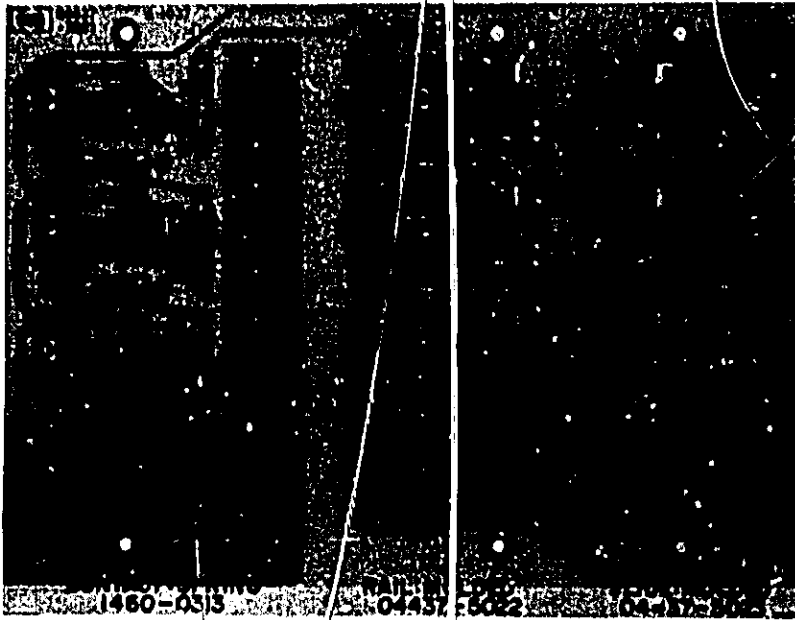

CHANGE 4

Change the mechanical parts in Table 6-2, Replaceable Parts and in Figure 8-3 Front Panel illustration as shown below:

Page 6-3, Table 6-2, change J2 to 1510-0056; BINDING POST, BLACK.
Page 6-3, Table 6-2, change J5 to 1510-0056; BINDING POST, BLACK.
Page 6-4, Table 6-2, change 04437-1129 to 04437-1120; PANEL:FRONT.
change 04437-1040 to 04437-1023; CHASSIS:MAIN.
change 04437-1038 to 04437-1033; ANGLE:L SIDE FRAME.
delete 04437-1039; INSULATOR.

Page 8-3, Figure 8-3,
Change part no. of center binding post of input terminals from 1510-0057
to 1510-0056.
Change part no. of lower binding post of output terminals from 1510-0057
to 1510-0056.

SCHEMATIC DIAGRAMS

SECTION VIII CIRCUIT DIAGRAM

8-1. INTRODUCTION

8-2. This section includes the following:

- a. General Notes for schematic diagram.
- b. Schematic Diagram and Parts Location Illustration.

8-3. GENERAL NOTES

- a. Unless otherwise indicated, resistance is in ohms, capacitance is in microfarads, and inductance is in microhenries.
- b. Components assigned an asterisk(*) are factory selected. Average values are shown.

c. The components mounted on chassis or main-frame parts are not assigned an assembly designation (i.e. R1, Q1, etc.).

d. Reference designations (R1, Q1, etc.) within assembly (A1, A2, . . . etc.) use the assembly designation as prefix to form complete designation (e.g. R1 in A1 assembly is A1R1).

e. The numbers 9.4.7 indicate the wire color code. Wire color code (MIL-STD-681) is the same as the resistor color code. First number identifies ground color, second number identifies wide stripe, and third number identifies narrow stripe, e.g. 9.4.7 denotes white ground, yellow wide stripe and violet narrow stripe.

8-4. Additional notes are shown in Figure 8-1.



Figure 8-1. Board Assembly

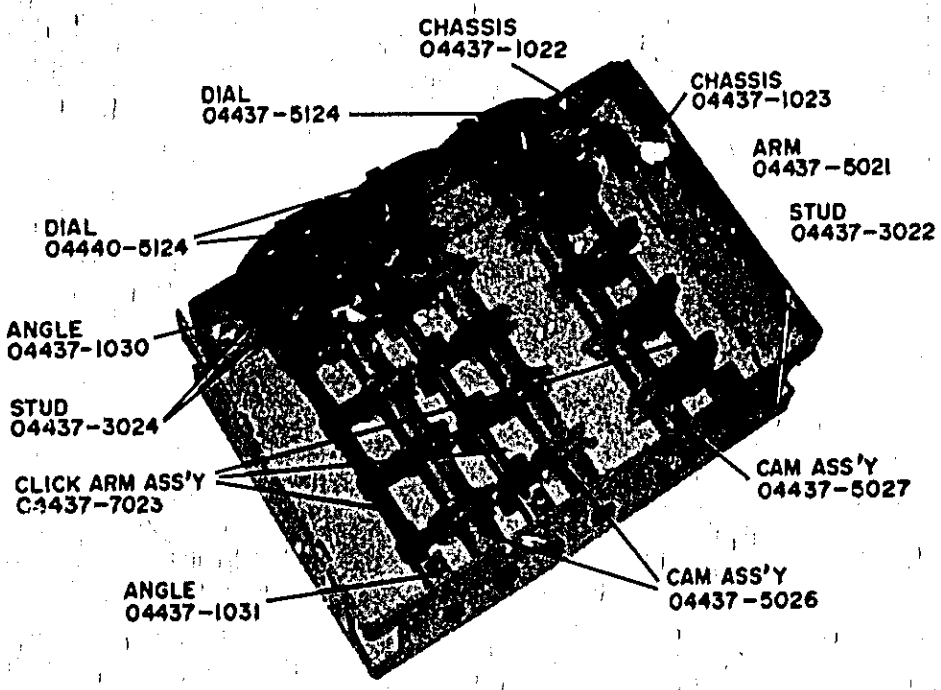

Figure 8-2. Cam Assembly

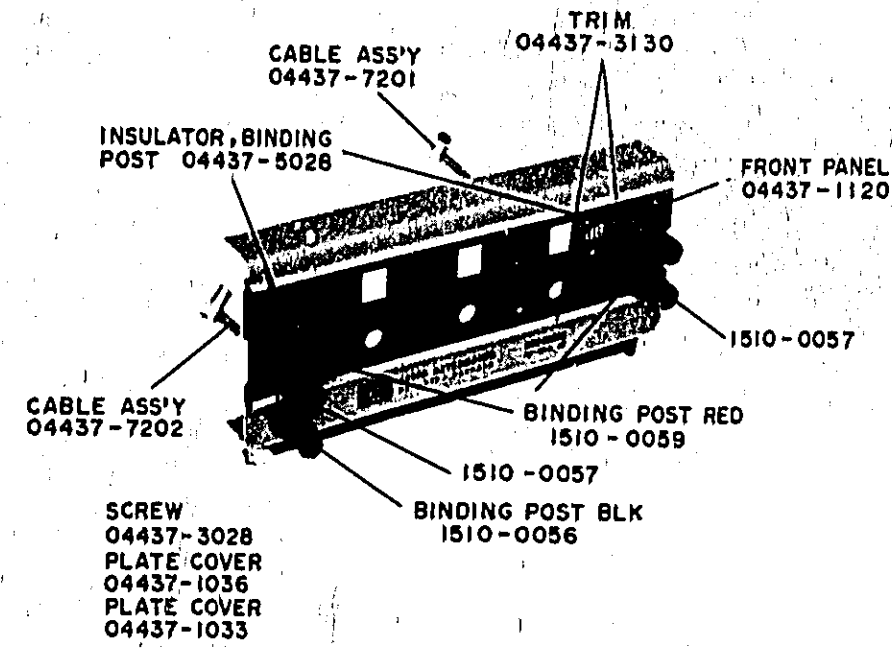
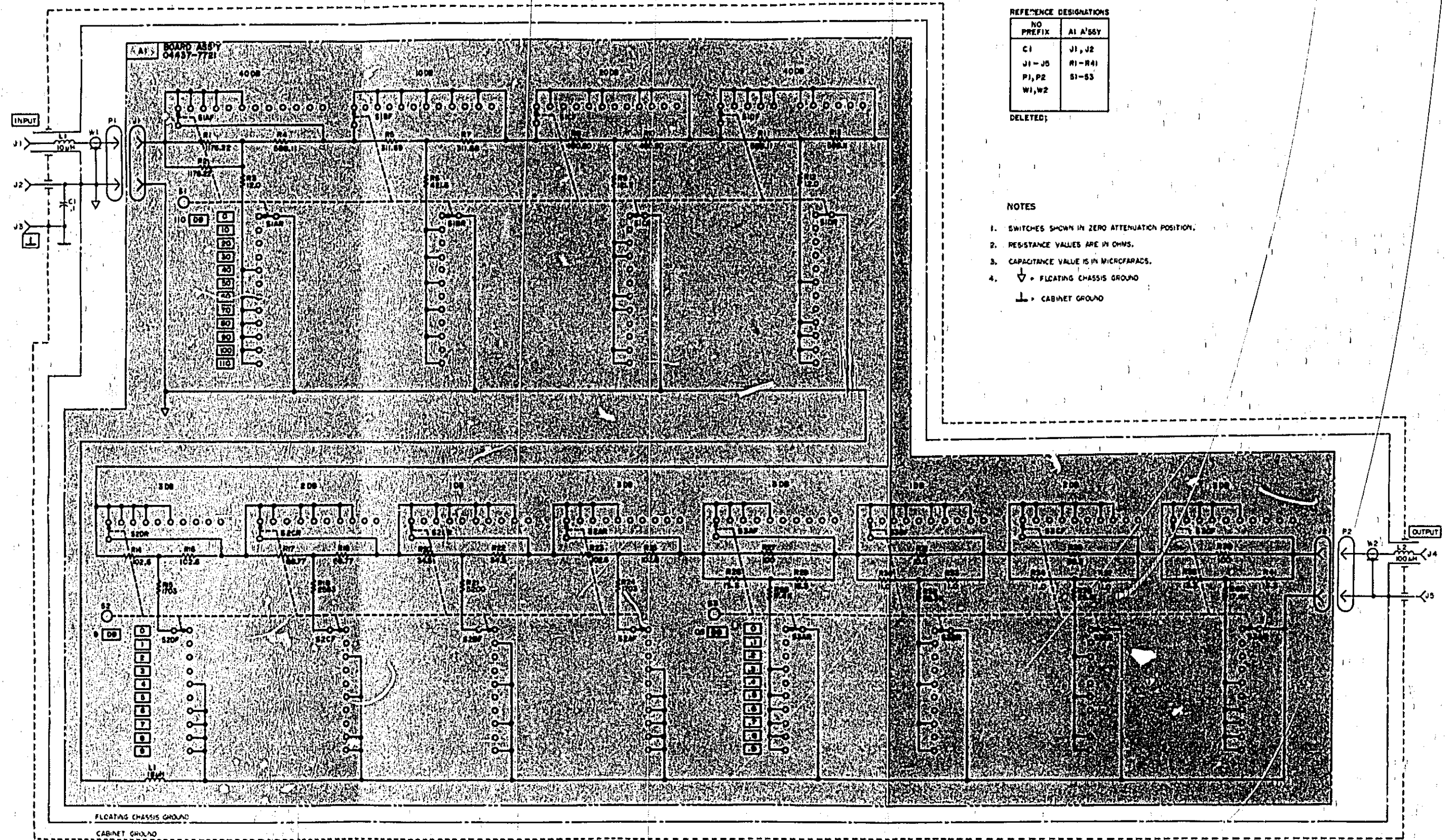

Figure 8-3. Front Panel



COPYRIGHT 1971 BY YOKOGAWA-HEWLETT-PACKARD, LTD.

Figure 8-4. Model 4437A Schematic Diagram

MANUAL CHANGES

MANUAL CHANGES

4437A

ATTENUATER

MANUAL IDENTIFICATION

Model Number: 4437A
Date Printed: NOV. 1983
Part Number: 04437-90003

This supplement contains important information for correcting manual errors and for adapting the manual to instruments containing improvements made after the printing of the manual.

To use this supplement:
Make all ERRATA corrections.
Make all appropriate serial number related changes indicated in the tables below.

SERIAL PREFIX OR NUMBER	MAKE MANUAL CHANGES	SERIAL PREFIX OR NUMBER	MAKE MANUAL CHANGES
1250J00246 and above	1		
1250J01581 and above	2		

► NEW ITEM

► ERRATA

Page 6-2 and 6-3, Table 6-2, Replaceable Parts:
See Table 1, Parts Information.

NOTE

Manual change supplements are revised as often as necessary to keep manuals as current and accurate as possible. Hewlett-Packard recommends that you periodically request the latest edition of this supplement. Free copies are available from all HP offices. When requesting copies quote the manual identification information from your supplement, or the model number and print date from the title page of the manual.

Date/Div: APR. 5, 1984/33

Page 1 of 3

Printed in Japan

 **HEWLETT
PACKARD**

Page 8-3, Figure 8-3, Front Panel:
Change the figure as shown below:

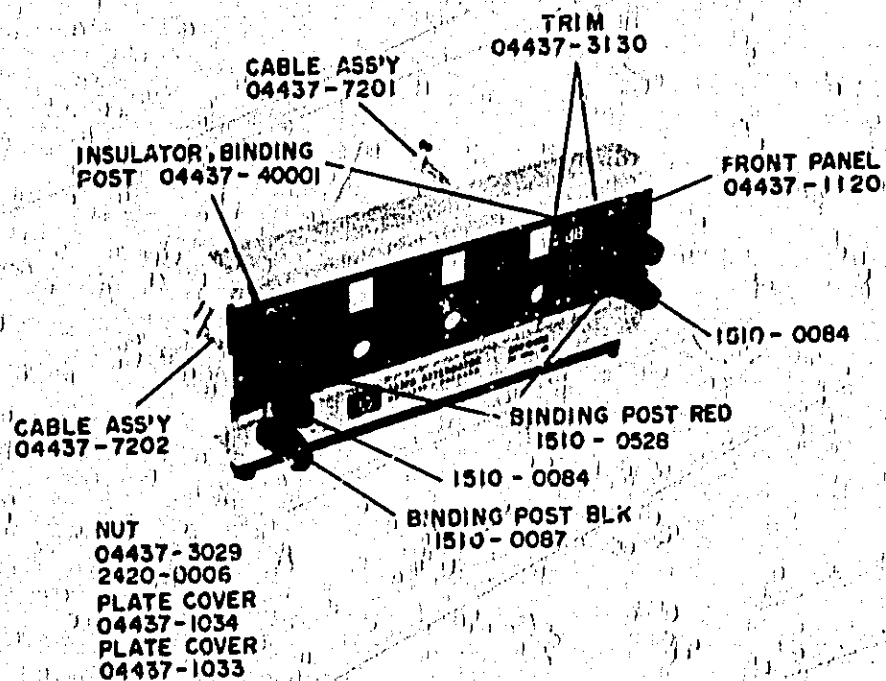
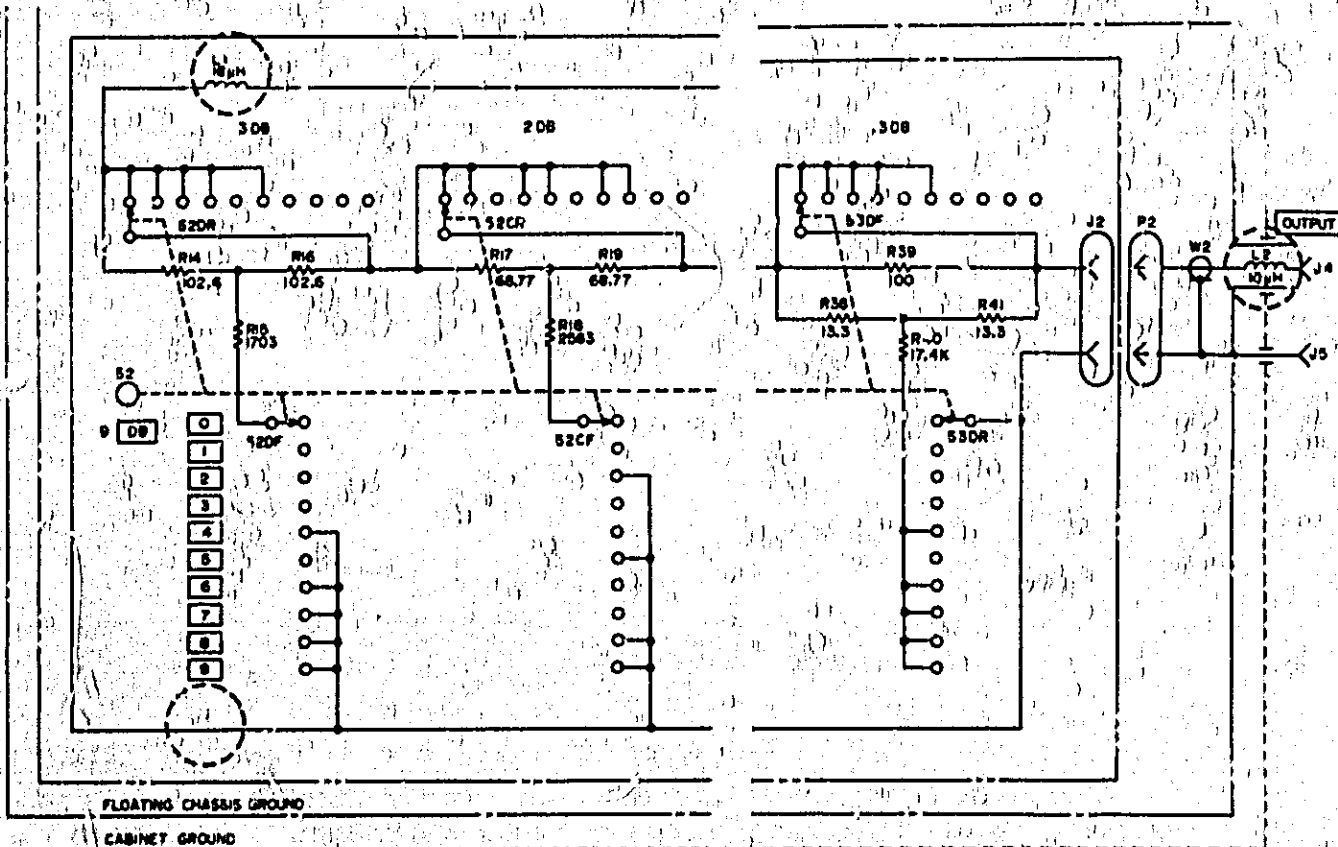

Figure 8-3: Front Panel

► CHANGE 1

Page 8-3, Figure 8-4, Model 4437A Schematic Diagram:
Partially change the diagram as follows:



▶ CHANGE 2

Page 6-3, Table 6-2, Replaceable Parts:
See Table 1, Parts Information.

Table 1. Parts Information

CHANGE	Page	Note	Reference Designation	HP Part Number	Description
ERRATA	6-2	▶ C	A1R3	0698-2095	R: FXD MET FLM 12.0Ω-0.5+0.25% 1/4W
		▶ C	A1R2	0698-2095	R: FXD MET FLM 12.0Ω-0.5+0.25% 1/4W
	6-3	▶ D	J1	04437-5030	
		▶ A	J1	0360-0270	LUG-SOLDER
		▶ A	J1	2190-0244	WSHR
		▶ C	J2	1510-0084	CONNECTOR: BINDING POST
		▶ A	J2	0360-0703	LUG-SOLDER
		▶ A	J2	2420-0006	NUT
		▶ A	J3	2420-0006	NUT
		▶ C	J4	1510-0528	CONNECTOR: BINDING POST RED
		▶ D	J4	04437-5030	
		▶ A	J4	2190-0244	WSHR
		▶ A	J4	0360-0270	LUG-SOLDER
		▶ A	J5	0360-0703	LUG-SOLDER
▶ A	J5	2420-0006	NUT		
2	6-3	▶ C	C1	0160-0013	C: FIX MY 0.1μF 10%

▶: New Item A: Add C: Change D: Delete