

Errata

Title & Document Type: 3730A Down Converter Operating and Service Manual

Manual Part Number: 03730-95004

Revision Date: June 1974

About this Manual

We've added this manual to the Agilent website in an effort to help you support your product. This manual provides the best information we could find. It may be incomplete or contain dated information, and the scan quality may not be ideal. If we find a better copy in the future, we will add it to the Agilent website.

HP References in this Manual

This manual may contain references to HP or Hewlett-Packard. Please note that Hewlett-Packard's former test and measurement, life sciences, and chemical analysis businesses are now part of Agilent Technologies. The HP XXXX referred to in this document is now the Agilent XXXX. For example, model number HP8648A is now model number Agilent 8648A. We have made no changes to this manual copy.

Support for Your Product

Agilent no longer sells or supports this product. You will find any other available product information on the Agilent Test & Measurement website:

www.agilent.com

Search for the model number of this product, and the resulting product page will guide you to any available information. Our service centers may be able to perform calibration if no repair parts are needed, but no other support from Agilent is available.



Agilent Technologies

DOWN CONVERTER

3730A

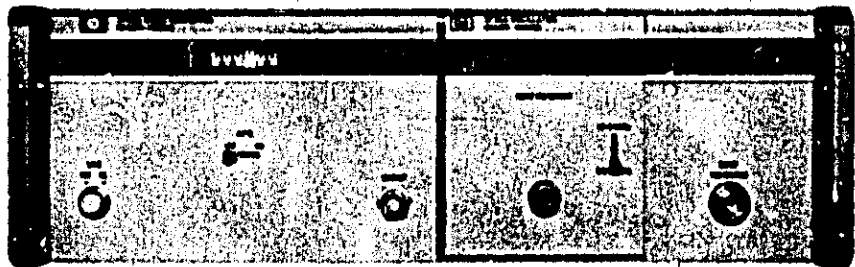

HEWLETT  PACKARD

CERTIFICATION

The Hewlett-Packard Company certifies that this instrument was thoroughly tested and inspected and found to meet its published specifications when it was shipped from the factory. The Hewlett-Packard Company further certifies that its calibration measurements are traceable to the U.S. National Bureau of Standards to the extent allowed by the Bureau's calibration facility.

WARRANTY AND ASSISTANCE

All Hewlett-Packard products are warranted against defects in materials and workmanship. This warranty applies for one year from the date of delivery, or, in the case of certain major components listed in the operating manual, for the specified period. We will repair or replace products which prove to be defective during the warranty period provided they are returned to Hewlett-Packard. No other warranty is expressed or implied. We are not liable for consequential damages.

Service contracts or customer assistance agreements are available for Hewlett-Packard products that require maintenance and repair on-site.

For any assistance, contact your nearest Hewlett-Packard Sales and Service Office. Addresses are provided at the back of this manual.

OPERATING AND SERVICE MANUAL

MODEL 3730A DOWN CONVERTER

SERIAL NUMBERS

This manual applies directly to instruments with serial numbers prefixed 1316U.

For instruments with serial prefixes other than this refer to the Manual Change Sheets.

For additional information about serial numbers, see Section I.

Copyright HEWLETT-PACKARD LIMITED 1974
SOUTH QUEENSFERRY, WEST LOTHIAN, SCOTLAND

Manual Part No. 03730-95004
Microfiche Part No. 03730-95029

Printed JUNE 1974

FOREWORD

This manual contains operating instructions and service information for the Hewlett-Packard Model 3730A Down Converter. The service information does not include details of the various plug-in Oscillators available for the Down Converter. Separate service manuals are available for this purpose.

These publications are also available in 6 1/4 x 4 in microfiche form. Each sheet contains up to 60 pages, maximum, of text and illustrations.

Order any of these publications through your nearest Hewlett-Packard office (addresses are given at the rear of this manual), quoting the complete number, name, and serial number of your Down Converter and/or Oscillator.

MANUAL CONTENT

- Section I** contains general information on the 3730A. Included are details on serial numbers, a description of the 3730A, a table of specifications, a list of options, and a list of recommended test equipment.
- Section II** gives full operating instructions for the Down Converter.
- Section III** gives detailed performance tests to enable the user to check that his Down Converter is functioning correctly and within the limits of its specification.
- Section IV** details the procedure for setting correctly the variable components in the 3730A.
- Section V** lists the replaceable parts in the Down Converter.
- Section VI** contains service information, including theory of operation, troubleshooting, circuit descriptions, component locations, and schematics for the 3730A.
- Section VII** contains manual backdating information to make this manual apply to instruments having serial number prefixes other than that listed under SERIAL NUMBERS on the title page (Page i).

SECTION III PERFORMANCE TESTS

Paragraph	3-1	INTRODUCTION	Page 3-1
	3-4	PERFORMING THE TESTS	3-1
	3-6	EQUIPMENT REQUIRED	3-1
	3-8	GENERAL SET-UP 1	3-1
	3-9	AMPLITUDE RESPONSE TEST	3-1
	3-10	SWEEP RANGE (AFC switch ON) TEST	3-2
	3-11	SWEEP RANGE (AFC switch OFF) TEST	3-2
	3-12	MINIMUM INPUT LEVEL TEST	3-3
	3-13	GROUP DELAY RESPONSE TEST	3-4
	3-14	GENERAL SET-UP 2	3-4
	3-15	METER ACCURACY TEST	3-5
	3-16	AFC CAPTURE TEST	3-6
	3-17	RETURN LOSS TEST	3-7
Table	3-1	Meter Accuracy Readings	3-6
Figure	3-1	General Set-up 1	3-2
	3-2	Equipment Set-up for Group Delay Response Test	3-5
	3-3	General Set-up 2	3-6

SECTION IV ADJUSTMENTS

Paragraph	4-1	INTRODUCTION	Page 4-1
	4-3	EQUIPMENT REQUIRED	4-1
	4-5	ADJUSTMENT LOCATIONS	4-1
	4-7	RELATED ADJUSTMENTS	4-1
	4-9	POWER SUPPLY ADJUSTMENTS	4-1
	4-10	IF CENTRE MHZ METER CALIBRATION	4-1
	4-11	EXCESS LEVEL ADJUSTMENT	4-2
	4-12	FLATNESS, GROUP DELAY & RETURN LOSS ADJUSTMENTS	4-2
Table	4-1	Power Supply Adjustments	4-1
Figure	4-1	Location of Adjustments	4-0
	4-2	Equipment Set-up for Amplitude Response Adjustment	4-3
	4-3	Equipment Set-up for Group Delay Response Adjustment	4-4

SECTION V REPLACEABLE PARTS

Paragraph	5-1	INTRODUCTION	Page 5-1
	5-3	ORDERING INFORMATION	5-1
	5-7	REFERENCE DESIGNATORS	5-1
	5-8	COLOUR ABBREVIATIONS	5-1
	5-9	STANDARD ABBREVIATIONS USED IN REPLACEABLE PARTS LIST	5-2
Table	5-1	Replaceable Parts	5-4

Assembly Service Sheet A3 – Loop Amplifier

Paragraph	A3-1	CIRCUIT DESCRIPTION	Page	6-24
Figure	A3-1	Simplified Block Diagram		6-24
	A3-2	Component Location and Grid Reference		6-27
	A3-3	Schematic – Assembly A3		6-27

Assembly Service Sheet A4/A5 – Rectifier and Regulator

Paragraph	A4-1	CIRCUIT DESCRIPTION	Page	6-28
	A4-4	+100V Supply		6-28
	A4-6	+15V Supply		6-28
	A4-8	+5V Supply		6-28
	A4-10	-15V Supply		6-28
	A4-12	20V Floating Supply		6-29
Figure	A4-1	Simplified Block Diagram – Assemblies A4/A5		6-28
	A4-2	Component Location and Grid Reference – A4		6-30
	A4-3	Component Location and Grid Reference – A5		6-31
	A4-4	Schematic – Assemblies A4 and A5		6-31

Assembly Service Sheet A6 – Group Delay Equaliser

Paragraph	A6-1	CIRCUIT DESCRIPTION	Page	6-32
Figure	A6-1	Simplified Block Diagram – Assembly A6		6-32
	A6-2	Component Location – A6		6-33
	A6-3	Schematic – Assembly A6		6-33

Assembly Service Sheet A7 – IF Amplifier (Option 010)

Paragraph	A7-1	CIRCUIT DESCRIPTION	Page	6-34
	A7-7	ADJUSTMENT PROCEDURE		6-34
Figure	A7-1	Simplified Block Diagram – Assembly A7		6-34
	A7-2	Component Location and Grid Reference – A7		6-37
	A7-3	Schematic – Assembly A7		6-37

Assembly Service Sheet A8 – IF Attenuator (Option 010)

Paragraph	A8-1	CIRCUIT DESCRIPTION	Page	6-38
Figure	A8-1	Simplified Block Diagram – Assembly A8		6-38
	A8-2	Component Location – A8		6-39
	A8-3	Schematic – Assembly A8		6-39

SECTION VII MANUAL CHANGES

Paragraph	7-1	INTRODUCTION	Page	7-1
	7-3	MANUAL BACKDATING		7-1
Figure	7-1	Part of Component Location, A5		7-2
	7-2	Part of Schematic Diagram – Assembly A4/A5		7-2
	7-3	Part of Component Location, A3		7-5
	7-4	Part of Schematic Diagram – Assembly A3		7-5

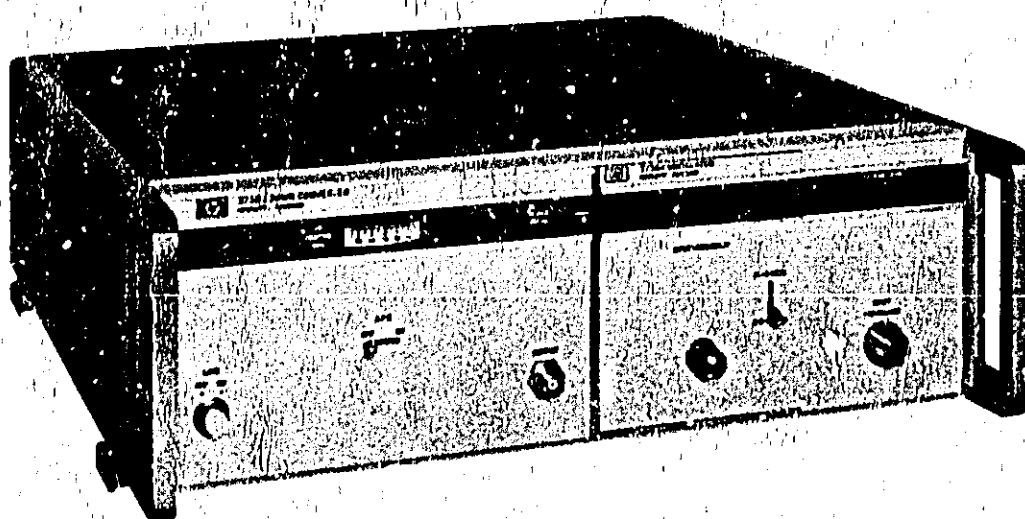

MODEL 3736A SHOWN IN PLUG-IN POSITION

Figure 1-1 Model 3730A Down Converter

SECTION I

GENERAL INFORMATION

1-1 INTRODUCTION

1-2 This manual contains basic operating instructions and complete service information for the 3730A Down Converter.

1-3 The manual is divided into six sections, each covering a specific topic or aspect of the instrument. The content of each section is summarized on Page ii of this manual.

1-4 This section contains a description of the 3730A, the instrument specifications (see Table 1-1), a list of available options (see Table 1-2), and a list of recommended test equipment for performance testing, adjusting, and troubleshooting the 3730A (see Table 1-3).

1-5 SERIAL NUMBERS

1-6 Instrument Identification

1-7 The instrument serial number is on a plate on the rear panel of the 3730A. The serial number is of the form - - - U - - - - , the number preceding the letter is the serial prefix and the number after the letter is unique to the particular instrument.

1-8 In all communications regarding the instrument, please quote the *complete* serial number.

1-9 Instruments Covered by Manual

1-10 The contents of this manual apply directly to instruments having the same serial number prefix as listed after SERIAL NUMBERS on the title page (Page i).

1-11 Information for backdating the contents of this manual to make it apply to earlier instruments is given in the Manual Changes section. Information for correcting errors and for updating the contents to cover improvements to the instrument that occur after the printing of this manual is provided, if re-

quired, in a Manual Changes supplement supplied with this manual.

1-12 For information concerning instruments with serial number prefixes not listed on the title page or in a Manual Changes supplement, contact the nearest Hewlett-Packard office — addresses are given at the rear of this manual.

1-13 DESCRIPTION

1-14 The Model 3730A Down Converter, including an Oscillator plug-in, is designed to "down-convert" RF to IF.

1-15 This is done by mixing the RF input with a signal of almost the same frequency supplied by the plug-in Oscillator. The IF output frequency from the mixer is equal to the difference in frequency between the RF input and the Oscillator output and can be in the range 45 to 95MHz.

1-16 Normally the IF output is centred on 70MHz. An automatic frequency control (AFC) feature in the 3730A can be switched on to prevent the IF output centre frequency drifting from 70MHz. When the AFC is switched on a signal from the Down Converter tunes the Oscillator frequency to compensate for any drift changes in the RF input frequency.

1-17 The Down Converter may be used in the design, testing, commissioning, and maintenance of microwave links. It is a valuable extension to the *hp* Microwave Link Analyzer, extending its capabilities into the RF region.

1-18 OPTIONS

1-19 A list of available options for the Down Converter is given in Table 1-2. Note that the options can only be fitted at the factory.

Table 1-1 Down Converter Specifications

3730A DOWN CONVERTER SPECIFICATIONS

RF INPUT (1 to 12GHz)		IF OUTPUT	
FREQUENCY:	Determined by Oscillator Plug-in	METER ACCURACY:	$\pm 0.5\text{MHz}$ at 70MHz $\pm 2\text{MHz}$ over rest of scale
ABSOLUTE MAX POWER:	+20dBm, 100mW	AUTOMATIC FREQUENCY CONTROL (AFC) - ON	
NOM. OPERATING LEVEL:	0dBm	CENTRE FREQUENCY CAPTURE:	Will capture an IF centre frequency up to at least $\pm 20\text{MHz}$ from 50MHz
MIN INPUT LEVEL:	20dBm (4dB high-level for correct operation of MLA) Option 010 adds 25dB Amplifier and 25dB (1dB steps) Attenuator reducing min input level to -84dBm (-40dBm for correct operation of MLA)	IF OUTPUT:	70 $\pm 0.5\text{MHz}$ IF can be unswpt. or swept sinusoidally from 0 to $\pm 75\text{MHz}$ at 18 to 100Hz
IMPEDANCE:	50 ohm	AUTOMATIC FREQUENCY CONTROL (AFC) - OFF	
SWR:	< 1.4	IF OUTPUT:	Manually tuned for IF centre frequency in the range 45 to 95MHz IF can be unswpt or swept at 0 to 500Hz, but must be within the range 45 to 95MHz
CONNECTOR:	N Female (mates with MIL C 71 and MIL C 30012 connectors)	IMPEDANCE:	75 ohm
		RETURN LOSS:	28dB min
		CONNECTOR:	B7 C Female

SYSTEM SPECIFICATIONS (Down Converter in Conjunction with hp MLA)

GROUP DELAY RESPONSE		AMPLITUDE RESPONSE	
RESIDUAL:	< 1% over any 50MHz band	RESIDUAL:	< 0.5dB over any 50MHz band (< 0.75dB with Option 010)
RANGE:	200ns	RANGE:	Calibrated to 3dB

3736A-9A OSCILLATOR SPECIFICATIONS

	MODEL 3736A	MODEL 3737A	MODEL 3738A	MODEL 3739A
FREQUENCY RANGE (GHz)	1.7 to 3.0 2.9 to 4.2	2.3 to 5.0 4.8 to 8.5	6.3 to 7.4 7.4 to 8.5	10.7 to 11.7
SCALE ACCURACY	$\pm 20\text{MHz}$	$\pm 20\text{MHz}$	$\pm 20\text{MHz}$	$\pm 20\text{MHz}$

GENERAL

		3730A	3736A	3737A	3738A	3739A	37301
POWER SUPPLY	Voltage	115 or 230V $\pm 10\%$					
	Frequency	48 to 66Hz					
TEMPERATURE	Operating Storage	0° to 50°C (32° to 122°F) 40° to 65°C (100° to 149°F)					
WEIGHTS	Net	23lb (10.5kg)		31b (14kg)		11b (4.9kg)	
	Shipping	33lb (15kg)		61b (27kg)		41b (18kg)	
DIMENSIONS	Width	16.75in (425mm)			4.25in (108mm)		
	Height	5.531in (141mm)			4.813in (122mm)		
	Depth	18.375in (467mm)			7.5in (191mm)		

Table 1-2 Down Converter Options

Option	Description
002	Siemens 2.5mm IF OUTPUT connector
003	Siemens 1.6mm IF OUTPUT connector
004	WECO 477B (equivalent) IF OUTPUT connector
010	Additional 25dB amplifier and 25dB variable attenuator

1-20 ACCESSORIES SUPPLIED

1-21 The following standard accessories are supplied with the 3730A Down Converter:

- Power Cable
- Rack Mounting Kit
- Servicing Extender Board

1-22 Instructions for rack mounting the instrument are supplied with the kit.

1-23 UNPACKING AND INSPECTION

1-24 If the shipping carton is damaged in any way, ask the carrier's agent to be present when the instrument is unpacked. Inspect the instrument for mechanical damage (scratches, dents, broken knobs, etc.). If the instrument is damaged, or fails to meet its specifications as detailed in Table 1-1, notify the carrier and the nearest Hewlett-Packard Sales and Service Office — addresses are given at the rear of this manual. The electrical performance of the instrument can be checked using the Performance Check given in Section III of this manual. Retain the shipping carton and padding material for the carrier's inspection. The Sales and Service Office will arrange for repair of the instrument without waiting for any claim settlement.

1-25 STORAGE AND SHIPMENT

1-26 Environment

1-27 The temperature during storage and shipment should be limited as follows:

- Minimum temperature: -40°C (-40°F)
- Maximum temperature: $+75^{\circ}\text{C}$ ($+167^{\circ}\text{F}$)

1-28 Repacking

1-29 Use the original shipping carton and packing material if available. The nearest Hewlett-Packard Sales and Service Office will provide information and recommendations on other materials if the original material has been discarded or is not reusable. Material should include:

- a. A double-walled carton, $25\text{kg}/\text{cm}^2$ ($350\text{lb}/\text{in}^2$) bursting test.
- b. Heavy paper, polythene, or sheets of cardboard to protect all instrument surfaces. Use extra material around all projecting parts.
- c. At least 10cm (4in) thickness of tightly-packed shock absorbing material surrounding the instrument.

1-30 Close the carton securely with durable shipping tape. If the instrument is to be shipped to a Hewlett-Packard Sales and Service Office, attach a tag to the instrument showing owner's name and address, model number, serial number, trouble symptoms and/or repairs required.

1-31 RECOMMENDED TEST EQUIPMENT

1-32 Table 1-3 lists the recommended test equipment to carry out the performance checks of Section III, the adjustments of Section IV and the troubleshooting of Section VI.

Table 1-3 Recommended Test Equipment

Instrument Type	Critical Specifications	Recommended Models	Use*
Microwave Link Analyzer	Unique	hp 3702B + 3705A, 3710A + 3716A	P. A.
Sweep Oscillator	Frequency between 1.7 and 11.7GHz (depends on plug-in in 3730A). Maximum power >+10dBm. Flatness <0.1dB. FM input: 0 to 1MHz.	hp 8605A with 784A Directional Detector	P. A.
Test Oscillator	Frequency: 10Hz to 1MHz. Output: >5V pk-pk into 75 ohm	hp 661B Option 002	P. A.
Oscilloscope	dc to 50MHz	hp 180A + 1801A + 1821A	P. A. T.
Electronic Counter	dc to 500MHz	hp 5300A + 5303B	P. A.
Digital Voltmeter	0 to 500V Accuracy: ±0.1V on 0 to 10V range.	hp 3470A	A. T.
Power Meter	-20 to +10dBm Frequency Range: 50MHz to 12GHz	hp 432A	P. A. T.
Double Balanced Mixer	Unique	RHG Electronics DM1-12	P. A.
Matching Pad	75 to 50 ohm	Rohde & Schwarz DAF 18084	P. A. T.
MLA Accessory Kit	Unique	hp 15550A	P. A. T.
Attenuator	30dB, 1.7 to 11.7GHz	hp 8491A	P.
Connectors		Sealectro SG50-674-6701-89 SG50-673-6700-83 SC50-678-0000-31	P. A. P. A. P. A.
	Adaptor Jack/OSM plug	OSM 21190	P. A.

*P = Performance Tests A = Adjustments T = Troubleshooting

SECTION II

OPERATING INSTRUCTIONS

2-1 INTRODUCTION

2-2 This section gives details of the operation of the Down Converter. Included are descriptions of the front and rear panel features on the 3730A and the plug-in Oscillator. These, and the operating instructions are presented in the form of operating plates for easy reference. Also given in this section are details of all the currently available plug-in Oscillators for the 3730A.

2-3 PANEL FEATURES

2-4 Descriptions of the Down Converter and plug-in Oscillator front panel controls, connectors, and indicators are given in Figure 2-1. The Oscillator rear panel connectors are described in Figure 2-2, and the Down Converter rear panel connectors in Figure 2-3.

2-5 OPERATING INSTRUCTIONS

2-6 Detailed instructions for operating the Down Converter and plug-in Oscillator are given in Figure 2-4. These instructions assume that the correct line voltage and fuse have been selected for the Down Converter and that the Oscillator has been correctly installed, as detailed in the Preparation for the Use instructions in this section.

2-7 PLUG-IN SELECTION

2-8 Currently there are four plug-in Oscillators available, the 3736A, 3737A, 3738A and 3739A. The Oscillator selected depends on the RF band being measured and the Oscillators available cover the main RF bands in use.

2-9 For frequencies not covered by these Oscillators an External Local Oscillator plug-in, the 37301A, is available. This permits the use of a sweep oscillator to provide the appropriate RF signal.

2-10 The plug-ins and their frequency ranges are listed in Table 2-1.

Table 2-1 Plug-in Selection

Plug-in	Frequency Band(s)
3736A	1.7 to 3.0GHz; 2.9 to 4.2GHz
3737A	3.3 to 5.0GHz; 4.8 to 6.5GHz
3738A	6.3 to 7.4GHz; 7.4 to 8.5GHz
3739A	10.7 to 11.7GHz
37301A	1 to 12GHz — depends on sweep oscillator used.

2-11 OPERATOR'S MAINTENANCE

2-12 Fuse

2-13 To change, or renew, the line fuse first switch off the LINE switch and disconnect the cable from the rear panel power module. Slide the plastic power module cover to the left. Lift the FUSE PULL lever to remove the fuse. When renewing the fuse, check that it has the correct rating.

2-14 PREPARATION FOR USE

2-15 Power Requirements

2-16 The Down Converter requires an ac power source of 115 or 230V $\pm 10\%$, 48 to 66Hz, single phase. Power consumption is approximately 85W. The 3730A provides dc power supplies for the plug-in Oscillator.

2-17 Interconnections

2-18 A// signal and power supply connections between the 3730A and the plug-in are automatically completed when the Oscillator is properly seated in the mainframe.

2-19 RF input and IF output signals are connected via front panel connectors, as appropriate.

2-20 Warm up

2-21 The Down Converter is ready for use immediately after switch-on but for best performance allow 15 minutes warm-up time.

FRONT PANEL FEATURES

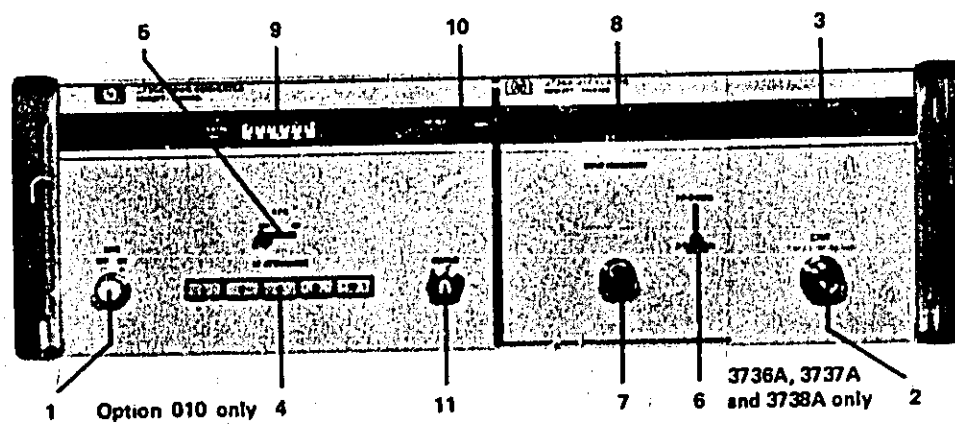

1. LINE pushbutton switch. Controls ac supply to the instrument.
2. INPUT coaxial connector. RF input connector.
3. EXCESS LEVEL lamp. Illuminates when the signal level at the IF OUTPUT 11 exceeds +12dBm.
4. ATTENUATOR five pushbutton switches. Fitted only to Option 010 Down Converter. 25dB attenuator, selectable in 1dB steps. Enables RF input to be attenuated if signal level is too great, as indicated by illuminated EXCESS LEVEL lamp 3.
5. AFC lever switch. Selects automatic frequency control. Set to OFF to set up Down Converter, then switch to ON to check that the frequency has locked at 70MHz, and leave set to ON.
6. FREQUENCY SELECTOR lever switch. Fitted only to 3736A, 3737A and 3738A Oscillators. Selects the frequency range of the Oscillator.
7. INPUT FREQUENCY potentiometer. Controls the output frequency of the Oscillator. Is used to set the frequency indicator 8 to the RF input frequency.
8. FREQUENCY INDICATOR. This is controlled by the INPUT FREQUENCY potentiometer 7 and it is used to set the Oscillator to the correct frequency, i.e. 70MHz less than the RF input centre frequency. By having the scale calibrated in terms of the RF input centre frequency rather than the oscillator output frequency, there is no need to remember if the Oscillator should be set 70MHz above or below the RF input centre frequency — just set the frequency so that the pointer indicates the RF input centre frequency.
9. IF CENTRE MHz meter. Indicates the IF output centre frequency. With the AFC switch 5 set to ON, the meter should normally indicate 70MHz.
10. SCALE UNCAL lamp. Illuminated when AFC switch 5 is set to ON to warn that the RF input centre frequency may not be that shown on the frequency indicator 8. The RF input centre frequency can drift. To overcome this, the Down Converter has an automatic frequency control feature that compensates for slow changes (but not sweep frequency changes) in the RF input frequency. Hence, the frequency indicator 8 may not show the correct RF input centre frequency when the AFC switch 5 is set to ON.
11. IF OUTPUT coaxial output connector. When AFC switch 5 is set to ON, output is 70 ± 0.5 MHz and can be swept sinusoidally from 0 to ± 25 MHz at 18 to 100Hz. When AFC switch 5 is set to OFF, output is manually tuned for IF centre frequency in the range 45 to 95MHz and can be swept from 0 to ± 25 MHz at 0 to 500Hz.

Figure 2-1 Down Converter & Oscillator Front Panel Controls, Connectors & Indicators

REAR PANEL FEATURES — OSCILLATOR

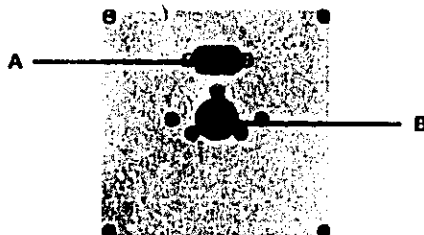

- A. INPUT 5-way connector. Provides automatic frequency control (AFC) input and power supplies from Down Converter.
- B. OUTPUT coaxial connector. Oscillator output to Down Converter.

Figure 2-2 Oscillator Rear Panel Connectors

REAR PANEL FEATURES — DOWN CONVERTER

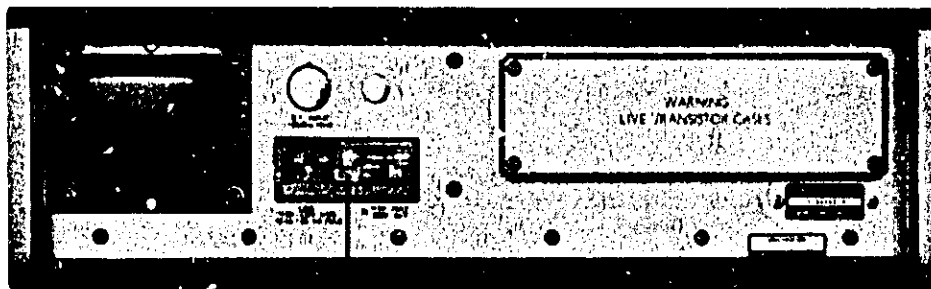

- 1. POWER MODULE contains ac line socket, fuse, and voltage selector.
AC LINE 115/230V, $\pm 10\%$, 48 to 66Hz.
FUSE 115V: 750mA, 230V: 400mA T clip-in fuse. Cannot be changed without first removing power cable.
SELECTOR lever switch, 115V or 230V line voltage selector. Cannot be changed without first removing power cable.

Figure 2-3 Down Converter Rear Panel Controls & Connectors

OPERATION

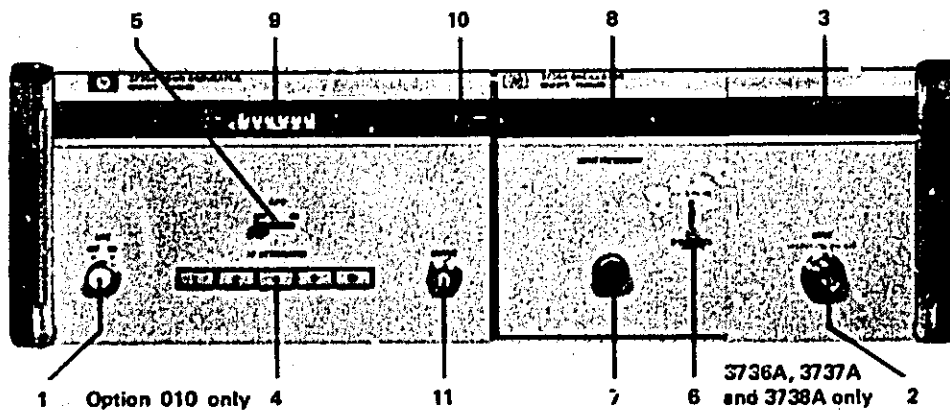

- a. Connect the Down Converter to the ac power supply.
- b. Set the LINE switch 1 to ON. Allow at least 15 minutes warm-up time.
- c. Set the range selector 6 and INPUT FREQUENCY control 7 to the RF input signal frequency on the indicator 8.
- d. Connect the RF signal to be measured to the INPUT connector 2. If the signal level is too great the EXCESS LEVEL lamp 3 will illuminate. Should this happen, reduce the signal level using an attenuator. Note that on Option 010 instruments an additional amplifier stage allows the 3730A to function with inputs down to -44dBm (-40dBm for correct operation of MLA). A 0 to 25dB attenuator is provided to prevent the additional amplifier saturating at inputs of above -18dBm .
- e. Set the AFC switch 5 to OFF.
- f. Fine tune the INPUT FREQUENCY control 7 to give an IF output centre frequency reading on the IF CENTRE MHz meter 9 of 70MHz.
- g. Set the AFC switch 5 to ON and verify that the IF CENTRE MHz meter is still reading 70MHz. If the needle has gone off-scale, set the AFC switch 5 to OFF, reduce the setting of the INPUT FREQUENCY control 7 until a second tuning point is found (ie the IF CENTRE MHz meter 9 again reads 70MHz), and return the AFC switch 5 to ON. Note that when the AFC switch 5 is ON the SCALE UNCAL lamp 10 is illuminated to inform the operator that the reading on the frequency indicator 8 may not be the true RF input frequency. The frequency indicator 8 is merely an aid to the initial setting up of the Down Converter.
- h. Connect the IF OUTPUT connector 11 as required.

Figure 2-4 Down Converter & Oscillator Operating Instructions

SECTION III

PERFORMANCE TESTS

3-1 INTRODUCTION

3-2 The procedures in this section test the instrument's electrical performance using the specifications of Table 1-1 as the performance standards.

3-3 In the following tests a 3736A plug-in Oscillator is used and the RF input frequency is set to 4GHz. Any other frequency in the range 1.7 to 11.7GHz may be chosen. The choice depends on the plug-in Oscillator selected and the sweep oscillator available.

3-4 PERFORMING THE TESTS

3-5 Carry out General Set-up 1 before doing the Amplitude Response, Sweep Range (AFC switch ON), Sweep Range (AFC switch OFF), and Minimum Input Level tests. The Group Delay Response test is complete in itself. Carry out General Set-up 2 before doing the Meter Accuracy and AFC Capture tests. The Return Loss test is also complete in itself.

3-6 EQUIPMENT REQUIRED

3-7 A full list of equipment required for all of the performance tests is given in the Recommended Test Equipment table in Section I of this manual. Any equipment that satisfies the critical specifications given in the table may be substituted for the recommended models.

3-8 GENERAL SET-UP 1

Procedure:

1. Set the test oscillator output to 70Hz, minimum amplitude, and connect its 75Ω output to the FM input of the sweep oscillator.
2. Set the INPUT FREQUENCY control on the 3736A plug-in Oscillator to 4GHz.
3. Set the sweep oscillator to 4GHz maximum

levelled power output. Connect the sweep oscillator output via a levelling detector to the RF INPUT of the 3730A. If the 3730A EXCESS LEVEL lamp illuminates, reduce the sweep oscillator power output level until the lamp extinguishes.

4. With the 3730A AFC switch OFF, fine tune the INPUT FREQUENCY control on the 3736A plug-in to give a 3730A IF CENTRE MHz meter reading of 70MHz. Set the 3730A AFC switch ON and check that the frequency locks on to 70MHz. (Note that there will be two possible 70MHz tuning points – at only one of these will the frequency lock to 70MHz when the AFC is switched ON.)
5. Connect the 3730A IF OUTPUT to the MLA receiver IF input. The equipment set-up should now be as shown in Figure 3-1 overleaf.

3-9 AMPLITUDE RESPONSE TEST

Specification: Residual Amplitude Response:
 <0.5dB over any 50MHz band
 (<0.75dB with Option 010)

Recommended Test Equipment:

MLA Receiverhp 3702B + 3705A
Sweep Oscillatorhp 8605A with 784A
	Directional Detector
Test Oscillatorhp 651B (Opt. 002)
ConnectorsSealectro SG 50-674-6701-89
	SG 50-673-6700-89
	SC 50-678-0000-31
	OSM 21190

Procedure:

1. Perform the procedure given in General Set-

3-13 GROUP DELAY RESPONSE TEST

Specification: Residual Group Delay Response:
<1ns over any 50MHz band.

Recommended Test Equipment:

MLA Transmitter *hp* 3710A + 3716A
MLA Receiver *hp* 3702B + 3705A
Sweep Oscillator *hp* 8605A with 784A
Directional Detector
Test Oscillator *hp* 651B (Opt. 002)
Double Balanced Mixer.. .RHG Electronics DM1-12
Connectors Sealectro SG 50-674-6701-89
SG 50-673-6700-89
SC 50-678-0000-31
OSM 21190

Procedure:

1. Set the test oscillator to give a 70Hz, 5V pk-pk amplitude output and connect its 75Ω output to the FM input of the sweep oscillator.
2. Set the sweep oscillator output to 4GHz, maximum levelled output. Connect the sweep oscillator output via a levelling detector to the RF input of the double balanced mixer.
3. Set the MLA transmitter to give a 90MHz unswept IF output with a 500kHz test tone and 500kHz deviation. The signal level from the transmitter should be approximately -7dBm. Connect this signal to the IF port of the double balanced mixer.
4. Set the INPUT FREQUENCY control on the 3736A plug-in Oscillator to 3.910GHz (ie 4GHz - 90MHz).
5. Connect the remaining port of the double balanced mixer to the 3730A RF INPUT. If the 3730A EXCESS LEVEL lamp illuminates, reduce the sweep oscillator power output level until the lamp extinguishes.
6. Disconnect the test oscillator output from the sweep oscillator.

7. Set the 3730A AFC switch OFF and fine tune the INPUT FREQUENCY control on the 3736A plug-in Oscillator to 3.910GHz to give a 3730A IF CENTRE MHz meter reading of 70MHz. Set the 3730A AFC switch ON and check that the frequency locks to 70MHz. Note that there will be two tuning points - one at 3.910GHz, the other at 4.090GHz. The lower frequency tuning point should be chosen.
8. Connect the 3730A IF OUTPUT port to the MLA receiver IF input.
9. Reconnect the test oscillator output to the sweep oscillator and adjust the test oscillator output amplitude until a swept IF display across ±25MHz is obtained. The equipment set-up should now be as shown in Figure 3-2.
10. Set the MLA receiver to display group delay. Calibrate the display for 1ns group delay over 3cm. The slope of the trace should be less than 3cm, ie the group delay response should be better than 1ns.

3-14 GENERAL SET-UP 2

Procedure:

1. Set the sweep oscillator output to 4GHz, maximum levelled output. Connect the sweep oscillator output via a levelling detector to the RF input of the double balanced mixer.
2. Connect the MLA transmitter auxiliary IF output to the electronic counter. Set the MLA transmitter to give a 70MHz unswept IF output. Using the electronic counter, check that the centre frequency is 70 ±0.1MHz.
3. With the signal level set to approximately -7dBm, connect the MLA transmitter IF output to the IF port of the double balanced mixer.
4. Set the INPUT FREQUENCY control on the 3736A plug-in Oscillator to 3.930GHz (ie 4GHz - 70MHz).

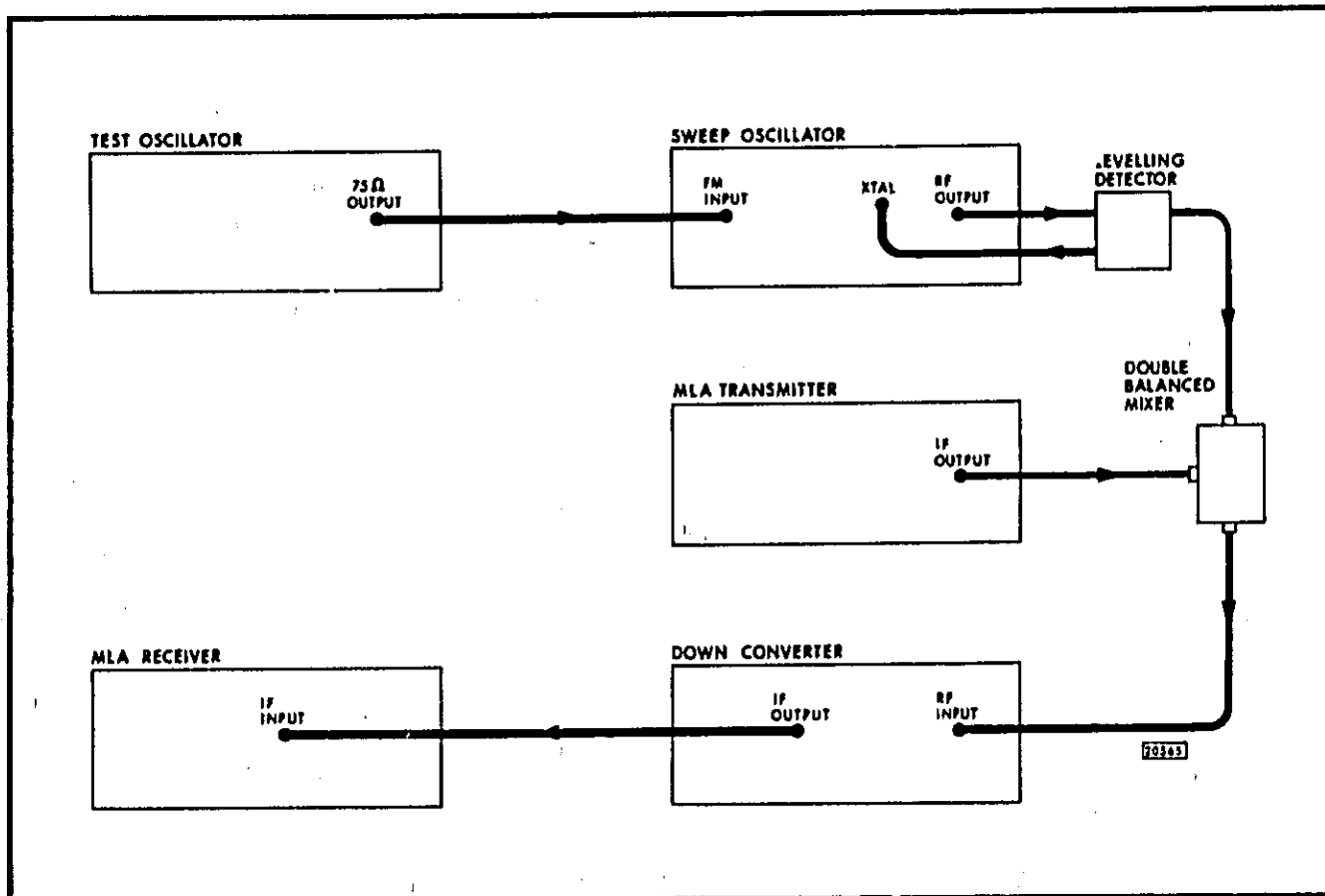

Figure 3-2 Equipment Set-up for Group Delay Response Test

5. Connect the remaining port of the double balanced mixer to the 3730A RF INPUT. If the 3730A EXCESS LEVEL lamp illuminates, reduce the sweep oscillator power output level until the lamp extinguishes.
6. Connect the 3730A IF OUTPUT to the MLA receiver IF input. The equipment set-up should now be as shown in Figure 3-3.
7. Set the 3730A AFC switch OFF and fine tune the INPUT FREQUENCY control on the 3736A plug-in Oscillator to 3.930GHz to give a 3730A IF CENTRE MHz meter reading of 70MHz. Set the 3730A AFC switch ON and check that the frequency locks to 70MHz. Note that there will be two tuning points – one at 3.930GHz, the other at 4.070GHz. The lower frequency tuning point should be chosen.
8. Set the 3730A AFC switch OFF.

3-15 METER ACCURACY TEST

Specification: Meter Accuracy:
 ± 0.5 MHz at 70 MHz
 ± 2 MHz over rest of scale

Recommended Test Equipment:

MLA Transmitter	hp 3710A
MLA Receiver	hp 3702B
Sweep Oscillator	hp 8605A with 784A
	Directional Detector
Electronic Counter	hp 5300A + 5303B
Double Balanced	
Mixer	RHG Electronics DM1-12
Connectors	Seaelectro SG 50-674-6701-89
	SG 50-673-6700-89
	SC 50-678-0000-31
	OSM 21190

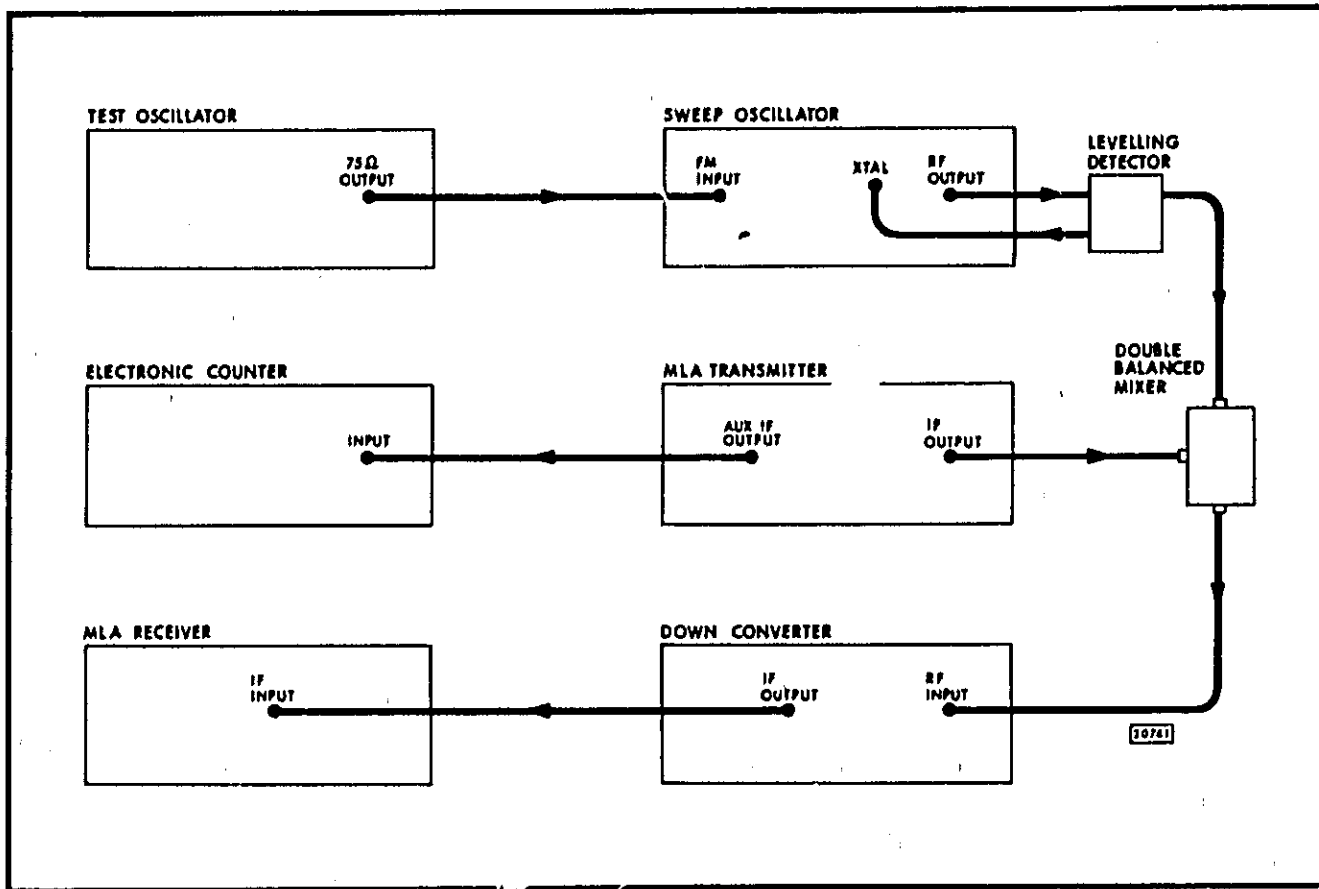

Figure 3-3 General Set-up 2

Procedure:

1. Perform the procedure given in General Set-up 2, Paragraph 3-14.
2. Set the MLA transmitter IF output centre frequency as detailed in Table 3-1. Check that the corresponding electronic counter readings and 3730A IF CENTRE MHz meter readings are correct

3-16 AFC CAPTURE TEST

Specification: Centre Frequency Capture:
Will capture an IF centre up to at least $\pm 20\text{MHz}$ from 70MHz.

Recommended Test Equipment:

MLA Transmitter hp 3710A
MLA Receiver hp 3702B

Table 3-1 Meter Accuracy Readings

Set MLA transmitter IF centre frequency to:	Check electronic counter reading is:	Check 3730A IF CENTRE MHz meter reading is:
50MHz	50MHz	90 \pm 2MHz
60MHz	60MHz	80 \pm 2MHz
70MHz	70MHz	70 \pm 0.5MHz
80MHz	80MHz	60 \pm 2MHz
90MHz	90MHz	50 \pm 2MHz

Sweep Oscillator *hp* 8605A with 784A
 Directional Detector
 Electronic Counter *hp* 5300A + 5303B
 Double Balanced
 Mixer RHF Electronics DM1-12
 Connectors Sealectro SG 50-674-6701-89
 SG 50-673-6700-89
 SC 50-678-0000-31
 OSM 21190

6. Set the 3730A AFC switch ON. Check that the IF CENTRE MHz meter reading returns to 70MHz.

3-17 RETURN LOSS TEST

Specification: Return Loss:
 28 dB minimum.

Procedure:

1. Perform the procedure given in General Set-up 2, Paragraph 3-14.
2. Set the MLA transmitter IF output centre frequency to 50MHz (ie, a 3730A IF CENTRE MHz meter reading of 90MHz).
3. Set the 3730A AFC switch ON. Check that the IF CENTRE MHz meter reading returns to 70MHz and the SCALE UNCAL lamp illuminates.
4. Set the 3730A AFC switch OFF.
5. Set the MLA transmitter IF output centre frequency to 90MHz (ie, a 3730A IF CENTRE MHz meter reading of 50MHz).

Recommended Test Equipment:

MLA Transmitter *hp* 3710A + 3716A
 MLA Receiver *hp* 3702B + 3705A
 MLA Accessory Kit *hp* 15550A

Procedure:

1. Connect the MLA transmitter and receiver to measure return loss using the mismatch technique.
2. Measure the return loss of the 3730A IF OUTPUT port. This should be not less than 28dB. The signal level into the hybrid should be -3dBm.

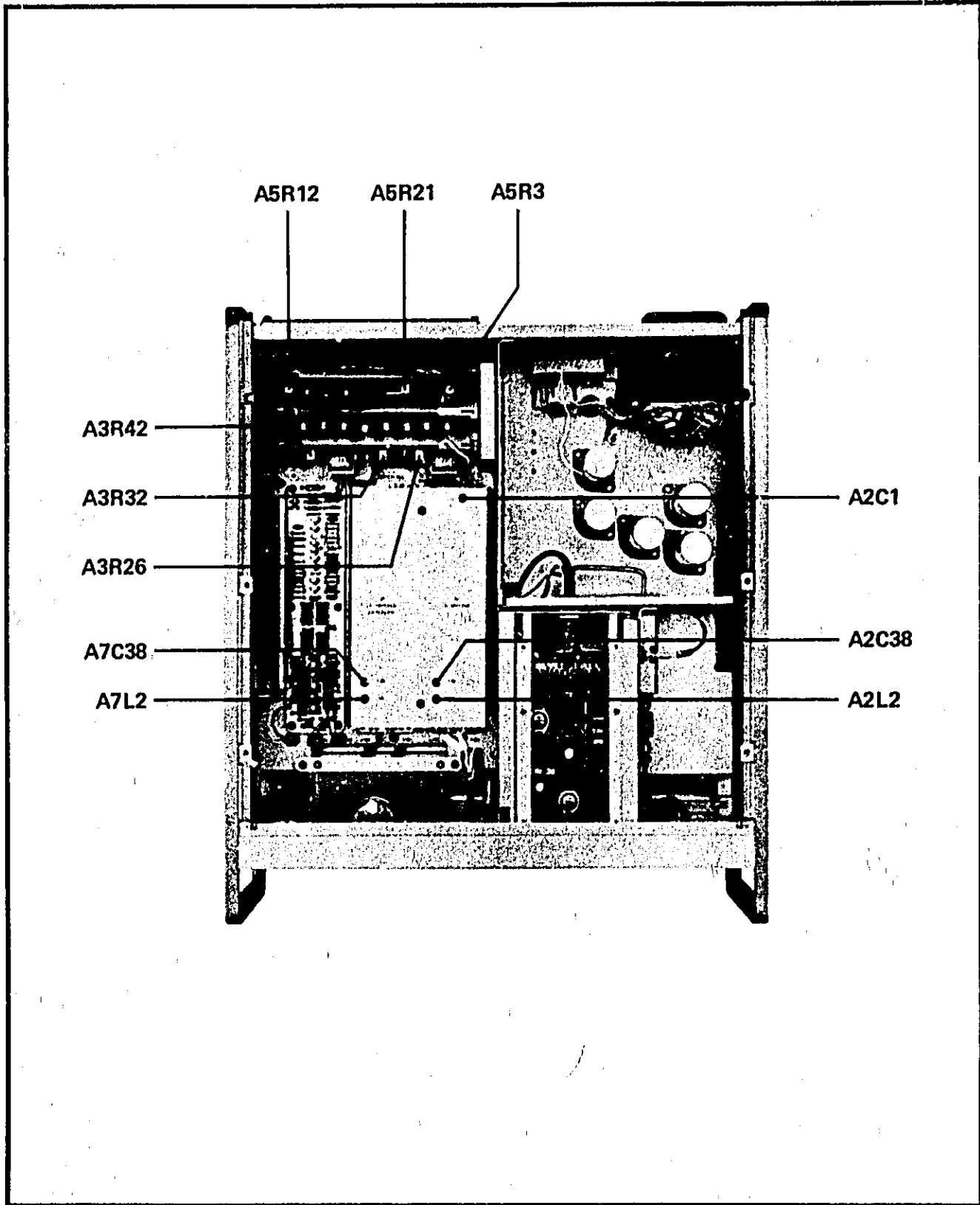

Figure 4-1 Location of Adjustments

SECTION IV ADJUSTMENTS

4-1 INTRODUCTION

4-2 This section details the procedure to be followed to set correctly the variable components in the Down Converter. When set correctly, the 3730A should meet its electrical specifications as detailed in Table 1-1 of this manual.

4-3 EQUIPMENT REQUIRED

4-4 A full list of equipment required for the adjustments procedures is given in the Recommended Test Equipment table in Section I of this manual. Any equipment that satisfies the critical specifications given in the table may be substituted for the recommended models.

4-5 ADJUSTMENT LOCATIONS

4-6 To gain access to the variable components, simply remove the top panel of the Down Converter. The locations of the adjustments are shown in Figure 4-1.

DANGER

115/230V AC WIRES ARE EXPOSED WHEN THE TOP PANEL OF THE DOWN CONVERTER IS REMOVED. USE EXTREME CAUTION DURING ADJUSTMENT PROCEDURES.

4-7 RELATED ADJUSTMENTS

4-8 Perform the adjustments in the order in which they are presented. The flatness, group delay, and return loss adjustments are interdependent and no attempt to adjust any or all of these parameters should be made unless absolutely necessary.

4-9 POWER SUPPLY ADJUSTMENTS

Recommended Test Equipment:

Digital Voltmeter *hp* 3470A
Oscilloscope *hp* 180A + 1801A + 1821A

Procedure:

1. Monitor the test points listed in Table 4-1 and measure the voltage and ripple on each. If necessary, adjust the appropriate component to set the voltage to the correct value. When adjusting the voltage, set the value to the tolerance quoted in brackets.

4-10 IF CENTRE MHZ METER CALIBRATION

Recommended Test Equipment:

MLA Transmitter *hp* 3710A
Electronic Counter *hp* 5300A + 5303B
Matching Pad 75/50Ω Rohde & Schwarz
DAF 18084

Table 4-1 Power Supply Adjustments

Test Point	Adjustment	Voltage	Ripple
A5(2)	A5R12	+15V ±30mV (±10mV)	<5mV
A5(14)	A5R21	-15V ±30mV (±10mV)	<5mV
Between A5(16) & A5(19) - floating supply	A5R30	20V ±30mV (±10mV)	<5mV
A5(8)	-	+100V ±5V	<50mV
A5(13)	-	+15V ±0.15V	<20mV

Procedure:

1. Set the MLA transmitter to give an unswept 70MHz, -10dBm IF Output. Monitor the auxiliary IF output using an electronic counter to check the frequency.
2. Disconnect the brown/red cable W912 from the A2J1 and connect the MLA transmitter IF output via a 75/50Ω matching pad to A2J1 on the 3730A.
3. Adjust A3R32 REF. ADJ. to set the IF CENTRE MHz meter to 70MHz.
4. Set the MLA transmitter output frequency to 50MHz and adjust A3R26 METER ADJ. to set the IF CENTRE MHz meter to 50MHz.
5. Set the MLA transmitter output frequency to 90MHz and check that the 3730A IF CENTRE MHz meter reads 90MHz. A slight readjustment of A3R26 METER ADJ. may be necessary.
6. Repeat steps 3, 4 and 5 of this procedure and, if necessary, slightly readjust A3R32 and A3R26 to give minimum error across the scale of the meter.
7. Disconnect the MLA transmitter and reconnect the brown/red cable W912 to A2J1.

4-11 EXCESS LEVEL ADJUSTMENT

Recommended Test Equipment:

Sweep Oscillator *hp* 8605A with 784A Directional Detector
 Power Meter *hp* 432A
 Matching Pad 75/50Ω Rohde & Schwarz DAF 18084 (or Greenpar 502-4718-708)

Procedure:

1. Set the INPUT FREQUENCY control on the 3736A plug-in Oscillator to 4GHz.
2. Set the sweep oscillator output to 4GHz. Set

the output level to approximately 0dBm.

3. Connect the sweep oscillator output via an external levelling detector to the RF INPUT of the 3730A.
4. With the 3730A AFC switch OFF, fine tune the INPUT FREQUENCY control on the 3736A plug-in Oscillator to give a 3730A IF CENTRE MHz meter reading of 70MHz. Set the AFC switch ON and check that the frequency locks onto 70MHz. (Note that there will be two possible 70MHz tuning points) at only one of these will the frequency lock to 70MHz when the AFC is switched ON).
5. Connect the 3730A IF OUTPUT port to the power meter via a 75/50Ω matching pad.
6. Adjust the sweep oscillator output level to set the power level at the 3730A IF OUTPUT port to +12dBm. Remember to allow for the power loss in the matching pad (Rohde & Schwarz matching pad power loss is 6dB; Greenpar matching pad power loss is 10dB).
7. Adjust A3R42 LEV. ADJ. potentiometer so that the EXCESS LEVEL lamp *just* illuminates.

4-12 FLATNESS, GROUP DELAY & RETURN LOSS ADJUSTMENTS

Note: The flatness, group delay, and return loss of the 3730A interact. Unless the 3730A is out of specification, do not attempt to adjust any of these parameters. When an adjustment may be necessary, first carry out the adjustments detailed in Assembly Service Sheet A2 (and Assembly Service Sheet A7 for Option 010 instruments) in Section VI, except for A2C38 (A7C38 Opt. 010).

Recommended Test Equipment:

MLA Transmitter *hp* 3710A + 3716A
 MLA Receiver *hp* 3702B + 3705A
 Sweep Oscillator *hp* 8605A with 784A Directional Detector
 Test Oscillator *hp* 651B (Opt. 002)
 Double Balanced Mixer. RHG Electronics DM1-12
 MLA Accessory Kit *hp* 15550A

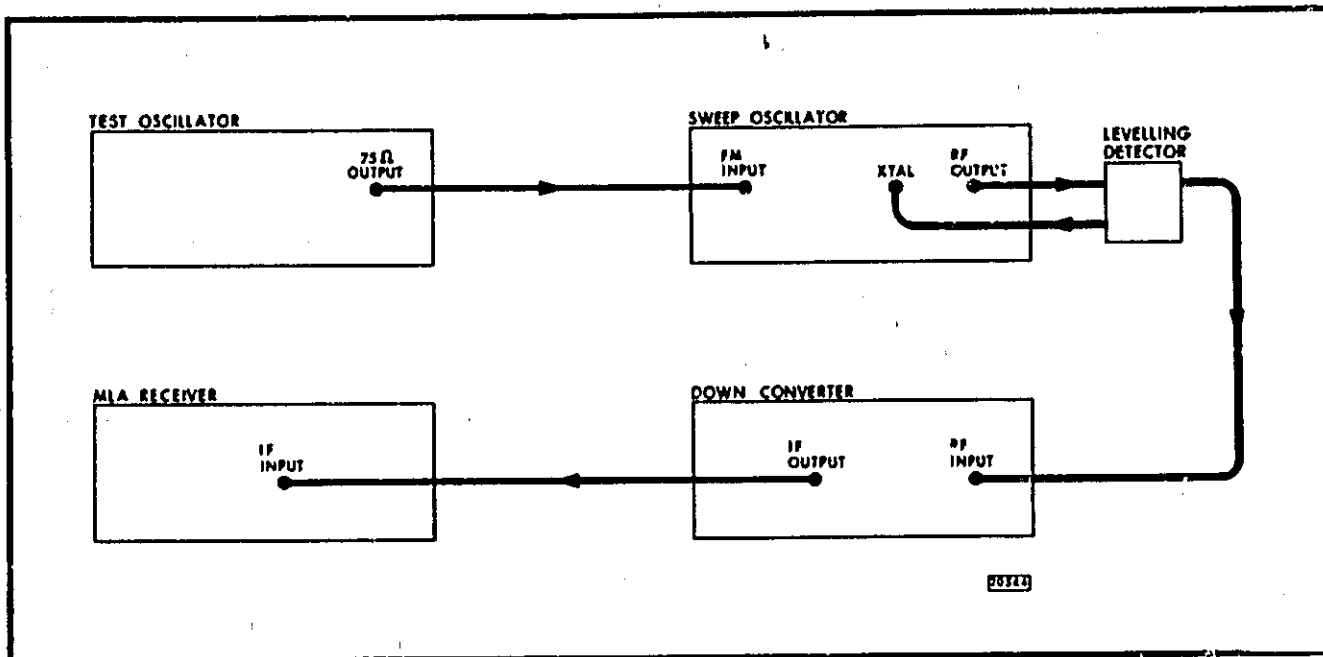

Figure 4-2 Equipment Set-up for Amplitude Response Adjustment

Flatness Procedure:

1. Set the test oscillator output to 70Hz minimum amplitude, and connect its 75Ω output to the FM input of the sweep oscillator.
2. Set the INPUT FREQUENCY control on the 3736A plug-in Oscillator to 4GHz.
3. Set the sweep oscillator to 4GHz maximum levelled power output. Connect the sweep oscillator output via a levelling detector to the RF INPUT of the 3730A. If the 3730A EXCESS LEVEL lamp illuminates, reduce the sweep oscillator power output level until the lamp extinguishes.
4. With the 3730A AFC switch OFF, fine tune the INPUT FREQUENCY control on the 3736A plug-in Oscillator to give a 3730A IF CENTRE MHz meter reading of 70MHz. Set the AFC switch ON and check that the frequency locks onto 70MHz. (Note that there will be two possible 70MHz tuning points — at only one of these will the frequency lock to 70MHz when the AFC is switched ON).
5. Connect the 3730A IF OUTPUT to the MLA receiver IF input. The equipment set-up should now be as shown in Figure 4-2.
6. Set the MLA receiver to display IF amplitude response and increase the test oscillator output amplitude until a swept IF display across ±25MHz is obtained.
7. Check that the IF amplitude response (or flatness) between 45 and 95MHz is better than 0.5dB (0.75dB for Option 010 instruments).
8. If the flatness is out of specification adjust A2C38 (and A7C38 for Option 010 instruments) for the optimum amplitude response.
9. If the flatness remains out of specification, refer to Assembly Service Sheet A2 (and Assembly Service Sheet A7 for Option 010 instruments).
10. Disconnect the amplitude response equipment set-up.

Return Loss Procedure:

11. Connect the MLA transmitter and receiver to

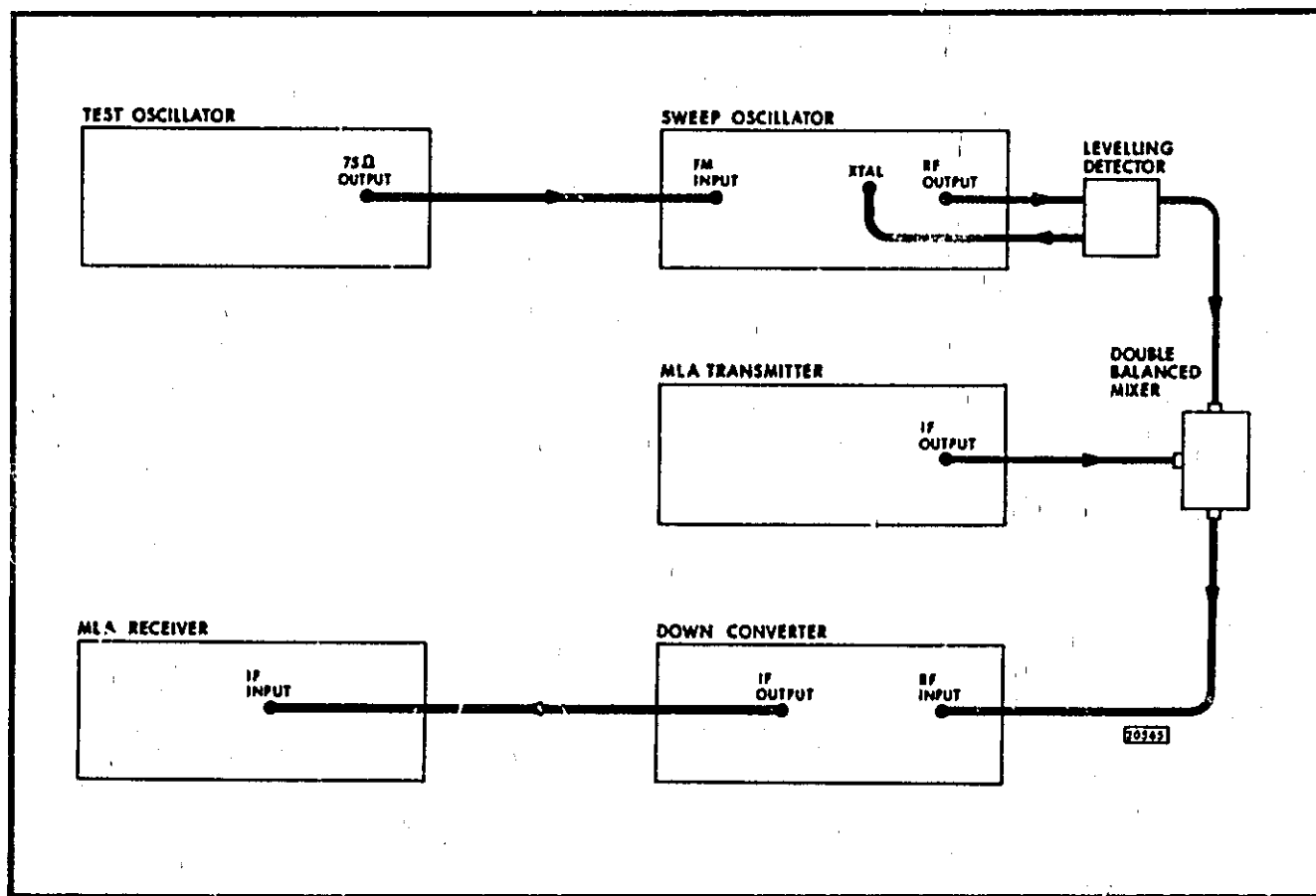

Figure 4-3 Equipment Set-up for Group Delay Response Adjustment

measure return loss using the mismatch technique.

12. Measure the return loss of the 3730A IF OUTPUT port. This should be not less than 28dB. The signal level into the hybrid should be -3dBm.
13. If the return loss is less than 28dB, check the return loss at A2J4 (A7J4 for Option 010 instruments). If the return loss is still out of specification refer to Assembly Service Sheet A2 (Assembly Service Sheet A7 for Option 010 instruments).
14. Disconnect the return loss equipment set-up.
15. Set the test oscillator to give a 70Hz, 5V pk-pk amplitude output and connect its 75Ω output to the FM input of the sweep oscillator.
16. Set the sweep oscillator output to 4GHz, maximum levelled output. Connect the sweep oscillator output via a levelling detector to the RF input of the double balanced mixer.
17. Set the MLA transmitter to give a 90MHz unswept IF output with a 500kHz test tone and 500kHz deviation. Set the signal level from the transmitter to -7dBm. Connect this signal to the IF port of the double balanced mixer.
18. Set the INPUT FREQUENCY control on the 3736A plug-in Oscillator to 3.910GHz (ie 4GHz - 90MHz).
19. Connect the remaining port of the double balanced mixer to the 3730A RF INPUT. If

Group Delay Response Procedure:

15. Set the test oscillator to give a 70Hz, 5V

the 3730A EXCESS LEVEL lamp illuminates, reduce the sweep oscillator power output level until the lamp extinguishes.

20. Disconnect the test oscillator output from the sweep oscillator.
21. Set the 3730A AFC switch OFF and fine tune the INPUT FREQUENCY control on the 3736A plug-in Oscillator to 3.910GHz to give a 3730A IF CENTRE MHz meter reading of 70MHz. Set the AFC switch ON and check that the frequency locks to 70MHz. Note that there will be two tuning points – one at 3.910GHz, the other at 4.090GHz. The lower frequency tuning point should be chosen.
22. Connect the 3730A IF OUTPUT port to the MLA receiver IF input.
23. Reconnect the test oscillator output to the sweep oscillator. The equipment set-up should now be as shown in Figure 4-3.
24. Set the MLA receiver to display group delay. Calibrate the display for 1ns group delay over 3cm. The slope of the trace should be less than 3cm, ie the group delay response should be better than 1ns.
25. If the instrument is out of specification, re-

peat the measurement with the IF amplifier in the MLA receiver by-passed. This will eliminate the possibility of the MLA receiver IF amplifier being the source of group delay error.

Note: To by-pass the IF amplifier in the 3702B, first remove the bottom panel. Disconnect the red/white lead from A22J2 and the brown/blue lead from A23J4. Connect the red/white lead to A23J4. Increase the input signal level to the 3702B by decreasing the 3710A IF attenuator setting by 12dB.

26. If the 3730A is still out of specification, adjust the variable components on the Group Delay Equaliser Assembly, A6. Note that adjustment of C1, T1, L1 and C3 on A6 will affect both the IF OUTPUT port return loss and the group delay response. Adjust these components to give the best compromise between the return loss and group delay response specifications.
27. Re-check the return loss and if necessary re-adjust the Group Delay Equalizer.
28. Repeat both checks as necessary until both return loss and group delay response specifications are met.

SECTION V REPLACEABLE PARTS

5-1 INTRODUCTION

5-2 This section contains information for ordering replacement parts. Table 5-1 lists parts in alphabetical order of their reference designators and gives the following information for each part:

- a. Hewlett-Packard part number.
- b. Description (abbreviations are listed later in this section).
- c. Total quantities of each part used in the instrument (TQ column).

5-3 ORDERING INFORMATION

5-4 To order a replacement part address the order or enquiry to your local Hewlett-Packard Service Office. These are listed at the rear of this manual.

5-5 Specify the following information for each part:

- a. Model and full serial number of instrument.
- b. Hewlett-Packard part number.
- c. Circuit reference designator.
- d. Description.

5-6 To order a part not listed in the tables, give a complete description of the part, including its function and location in the instrument.

5-7 REFERENCE DESIGNATORS

A	=	assembly
B	=	motor
C	=	capacitor
CR	=	diode
DL	=	delay line
DS	=	lamp

E	=	miscellaneous electrical part
F	=	fuse
IC	=	integrated circuit
J	=	connector
K	=	relay
L	=	inductor
M	=	meter
MC	=	micro circuit
MP	=	miscellaneous mechanical part
P	=	plug (male)
Q	=	transistor
R	=	resistor
S	=	switch
SR	=	shift register
T	=	transformer
TP	=	test point
V	=	vacuum tube
W	=	cable
XA	=	printed circuit board edge connector
XF	=	fuse holder
XV	=	CRT connector
Y	=	crystal
Z	=	attenuator
ZZ	=	packaging material

5-8 COLOUR ABBREVIATIONS

BLK	=	black (0)
BRN	=	brown (1)
RED	=	red (2)
ORN	=	orange (3)
YEL	=	yellow (4)
GRN	=	green (5)
BLU	=	blue (6)
VIO	=	violet (7)
GRY	=	grey (8)
WHT	=	white (9)
SILV	=	silver

5-9 STANDARD ABBREVIATIONS USED IN REPLACEABLE PARTS LIST

A	=	ampere	DPST	=	double pole, single throw
AC	=	alternating current	D/A	=	digital to analog
AFC	=	automatic frequency control	EHT	=	extra high tension
AL	=	aluminium	EXT	=	external
ALC	=	automatic level control	FET	=	field effect transistor
AM	=	amplitude modulation	FM	=	frequency modulation
AMPL	=	amplifier	FREQ	=	frequency
ATTEN	=	attenuator	FXD	=	fixed
ASSY	=	assembly	GD	=	group delay
AT	=	ampere (timed)	GE	=	germanium
			GHZ	=	gigahertz (10^9 Hz)
BAL	=	balanced	H	=	henry
BB	=	baseband	HEL	=	helical
BD	=	board	HORIZ	=	horizontal
BHD	=	bulkhead	HS	=	high speed
BKDN	=	breakdown	HV	=	high voltage
BKT	=	bracket	HZ	=	hertz
BNC	=	connector type	IC	=	integrated circuit
			IF	=	intermediate frequency
C	=	capacitor	INCD	=	incandescent
CAL	=	calibrated	IND	=	inductor
CBL	=	cable	INT	=	internal
COAX	=	coaxial	INV	=	inverter
COMP	=	compensated	I/P	=	input
CONCEN	=	concentric	J-K	=	flip-flop type
CONHEX	=	hexagonal connector	K	=	kilo (10^3)
CONN	=	connector	KHZ	=	kilohertz (10^3 Hz)
CONST	=	constant	LIN	=	linear
CONT	=	controlled	LOG	=	logarithmic
CONV	=	converter	LP	=	low pass
CRT	=	cathode ray tube	LPPM	=	low parts per million
DB	=	decibel			
DBM	=	decibel (ref. 1MW)			
DC	=	direct current			
DEG	=	degree			
DEV	=	deviation			
DIA	=	diameter			
DIFF	=	differential			
DIO	=	diode			
DLY	=	delay			
DPDT	=	double pole, double throw			

LVR	=	lever	RF	=	radio frequency
M	=	mega (10^6)	RLY	=	relay
MA	=	milliampere (10^{-3} A)	RMS	=	root mean square
MAT	=	milliampere (timed)	RND	=	round
MECH	=	mechanism	RTRY	=	rotary
MED	=	medium	RVT	=	rivet
MHZ	=	megahertz (10^6 Hz)	S	=	second (time)
MIN	=	miniature	SCR	=	screw
MOD	=	modulated	SI	=	silicon
MT	=	mount	SKT	=	socket
MTG	=	mounting	SMA	=	connector type
MTR	=	meter	SPDT	=	single pole, double throw
MW	=	milliwatt (10^{-3} W)	ST	=	selected on test
NAND	=	not and	SW	=	switch
NOM	=	nominal	S/R	=	semi-rigid
NSR	=	not separately replaceable	T	=	throw (position)
OBD	=	order by description	TEMP	=	temperature
OPER	=	operational	TERM	=	terminal
OSC	=	oscillator	TGL	=	toggle
O/P	=	output	TQ	=	total quantity
P	=	pole	TUN	=	tunnel (diode)
PB	=	pushbutton	TVSC	=	television sub-carrier (colour)
PC	=	printed circuit	UF	=	microfarad (10^{-6} F)
PF	=	pico farad (10^{-12} F)	UH	=	microhenry (10^{-6} H)
PIN	=	positive intrinsic- negative	UNBAL	=	unbalanced
PIV	=	peak inverse volts	V	=	volt
PM	=	phase modulation	VAL	=	value
PNL	=	panel	VAR	=	variable
PPM	=	parts per million	VERT	=	vertical
PPM/C	=	parts per million per degree celsius	W	=	watt
PWR	=	power	WVDC	=	working volts direct current
QUAD	=	quadruple	XFMR	=	transformer
R	=	resistor	XR	=	expander
REC	=	rectifier	XSTR	=	transistor
REF	=	reference	XTAL	=	crystal
			YIG	=	yttrium iron garnet

Table 5-1 Replaceable Parts

Ref Desig	HP Part No	TQ	Description
			ACCESSORIES
	03730-95004	1	MANUAL SERVICE 3730A
	5060-8740	1	KIT RACK MTC
	8120-1351	1	CBL PWR #ST0A
	8120-1348	1	CBL PWR #US & CANADA
	8120-1349	1	CBL PWR #SCANDINAVIAN
	03730-70035	1	BO EXTENDER SERVICING
C1	0180-0398	1	C FXD 350UF +50-10% 100MVDC
	1520-0002	5	MT C
C2	0180-1999	4	C FXD 700UF +100-10% 50MVDC
	1520-0002		MT C
C3	0180-1999		C FXD 700UF +100-10% 50MVDC
	1520-0002		MT C
C4	0180-1999		C FXD 700UF +100-10% 50MVDC
	1520-0002		MT C
C5	0180-1999		C FXD 700UF +100-10% 50MVDC
	1520-0002		MT C
C6	0160-2657	1	C FXD DUAL 1000PF 1000MVDC
C7			NOT ASSIGNED
C8			NOT ASSIGNED
C9			NOT ASSIGNED
C10	0160-0663	4	C FXD 1000PF (FEEDTHRU)
C11	0160-0663		C FXD 1000PF (FEEDTHRU)
C12	0160-0663		C FXD 1000PF (FEEDTHRU)
C13	0160-0663		C FXD 1000PF (FEEDTHRU)
C14	0160-0155	1	C FXD 3300PF 10% 200MVDC
C15	0150-0121	1	C FXD 0.1UF +80-20% 50MVDC
DS1	2140-0244	1	LAMP INCD 95V 1A (PART OF SLD)
DS2	2140-0092	2	LAMP INCD 5V 60MA #SCALE UNCALB
	1450-0371	2	LENS AMBER
	1450-0153	2	LAMPHOLDER
DS3	2140-0092		LAMP INCD 5V 60MA #EXCESS LEVELB
	1450-0371		LENS AMBER
	1450-0153		LAMPHOLDER
E1	5060-1189	1	MODULE PWR
E2	0460-0174	1	MIXER
E3	03730-70037	1	ASSY FILTER #RED
E4	03730-70038	1	ASSY FILTER #BLU
E5	03730-70039	1	ASSY FILTER #GRN
F1	2110-0340	1	FUSE SLOW BLOW 400MAT 250V#230V LINE#
	2110-0379	1	FUSE SLOW BLOW 750MAT 250V#115V LINE#
F2	2110-0011	1	FUSE 620MA 250V #100V#
F3	2110-0063	2	FUSE 750MA 250V #15V#
F4	2110-0065	1	FUSE 375MA 250V #15V#
F5	2110-0001	1	FUSE 1A 250V 1-15V#
F6	2110-0063		FUSE 750MA 250V #20V#
	2110-0288	1	FUSEHOLDER #F2-#8 #NSR#
J1			REFER TO W911
J2			REFER TO W910

Ref Desig	HP Part No	TQ	Description
J3			REFER TO W917
J4			REFER TO W913
M1	1120-1541	1	MTR 1PA CENTRE ZERO #IF CENTRE #M2#
NP1	03730-10001	1	PNL FRONT LT
	03730-10002	1	PNL SUB LT
	03702-336	1	1IN DOWEL #TC2#
	03730-10101	1	EXTRUSION PNL FRONT LT
	03730-10003	1	INSERT PNL FRONT LT
	03730-10018	1	BKT MTR
	7120-1254	1	PLATE TRADEMARK
NP2	03730-10010	1	PNL FRONT RT
	03730-10011	1	PNL SUB RT
	03730-10104	1	EXTRUSION PNL FRONT RT
	03730-10012	1	INSERT PNL FRONT RT
NP3	5020-4135	1	PNL TRIM TOP
	5000-0910	1	CLAMP TRIM PNL #TC 2#
NP4	5020-4136	1	PNL TRIM BOTTOM
NP5	5040-8732	2	FRAME SIDE LT
	5000-8713	2	PNL SIDE FRONT LT
	5000-8769	2	PNL SIDE REAR LT
	5040-0722	2	ASSY HANDLE SIDE LT
	5040-8137	2	RETAINER HANDLE LT
	5000-0051	2	PLATE FLUTED AL LT
	03730-10013	2	BKT SUPPORT PC BO LT
	0403-0141	1	GUIDE PC BO - BLK
	0403-0141	1	GUIDE PC BO - BLK
	0403-0141	1	GUIDE PC BO - BLK
	03730-10017	1	BKT MTC EXTENDER
NP6	5040-8732		FRAME SIDE RT
	5000-8711		PNL SIDE FRONT RT
	5000-8769		PNL SIDE REAR RT
	5040-0722		ASSY HANDLE SIDE RT
	5040-8737		RETAINER HANDLE RT
	5000-0051		PLATE FLUTED AL RT
NP7	5040-8589	1	PNL TOP
NP8	03730-10046	1	PNL BOTTOM
	5040-8767	1	ASSY FOOT #TQ5#
	1490-0030	1	STAND FILL
NP9	03730-10006	1	PNL REAR
	03730-10009	1	COVER #STR
	7120-0608	1	PLATE SERIAL
NP10	03730-10004	1	DECK MAIN
NP11	03730-10015	1	DECK SIDE
	03730-10014	1	BOX EQUALISER
NP12	03730-10007	1	HOUSING PLUG-IN
	03730-10013	1	BKT SUPPORT PC BO RT
	0403-0144	1	GUIDE PC BO-GRN
	0403-0145	1	GUIDE PC BO-YEL
	0403-0146	1	GUIDE PC BO-BRN
NP14	03730-10008	1	WALL REAR
	03730-10102	1	PIN LOCATION #TQ2#
NP15	03730-10005	1	DECK PWR
NP16	03730-10028	1	COVER SCREENING #AT#
	03730-10015	1	SUPPORT SCREENING

Abbreviations are listed in the introduction to this section

Table 5-1 Replaceable Parts (continued)

Ref Desig	HP Part No	TQ	Description
Q1	1854-0072	2	XSTR SI NPN
	1200-016A	2	BASE MTG XSTR #010
	0340-0162	2	INSULATOR XSTR #010
Q2	1854-0063	3	XSTR SI NPN
	1200-0041	3	BASE MTG XSTR #020
Q3	1200-0043	3	INSULATOR XSTR #020
	1854-0072		XSTR SI NPN
	1200-016A		BASE MTG XSTR #010
	0340-0162		INSULATOR XSTR #010
Q4	1854-0063		XSTR SI NPN
	1200-0041		BASE MTG XSTR #040
Q5	1200-0043		INSULATOR XSTR #040
	1854-0063		XSTR SI NPN
	1200-0041		BASE MTG XSTR #050
R1	1200-0043		INSULATOR XSTR #050
	0698-4736	1	P FXD 34.8K OHM 1% 1/4W
S1	3101-1248	1	SM PB SPOT LIGHTED LENS WHT ALINE OFF/ON#
S2	3100-0666	1	SM LVR ACTUATED RTAY OPDT/AFIC OFF/ON#
	0370-0929	1	KNOB LVR #520
T1	9100-0630	1	XFMR LINE
W100	03730-700C9	1	ASSY CBL MAIN HARNESS
	03730-7001C	1	ASSY COAX CBL BRN/BLK
W910	1250-1281	2	CONN COAX CBL MTG 3/16 DIA 5 OHM #21J10
	08699-20039	1	BODY CONN RF TYPE 4 #2.0
W911	1250-1120	1	INSULATOR CONN RF #J20
	1250-1121	1	NUT CONN RF #J20
W912	1250-1122	1	CONTACT CONN RF #J20
	08731-210	1	NUT LOCK CONN RF #J20
W913	03730-70011	1	ASSY COAX CBL BRN/BRN
	1250-0610	1	CONN COAX SHD MTG TNC 75 OHM #J10
W914	1250-0931	6	CONN COAX CBL MTG CONNEX #A2J20
	03730-70012	1	ASSY COAX CBL BRN/RED
W915	1250-1301	1	CONN COAX CBL 4T 50 OHM RT ANGLE #E2J20
	1250-1354	1	CONN COAX CBL MTG CONNEX 50 OHM #A2J10
W916	03730-70013	1	ASSY COAX CBL BRN/ORN
	1250-1318	1	CONN COAX S/R RF SHD MTG CONNEX #J40
W917	1250-1281	1	CONN COAX CBL MTG SMA 50 OHM #E2J10
	03730-70014	1	ASSY COAX CBL BRN/YEL
W918	1250-0931	1	CONN COAX CBL MTG CONNEX #A2J40
	1250-0931	1	CONN COAX CBL MTG CONNEX #A6J10
W919	03730-70015	1	ASSY COAX CBL BRN/GRN
	1250-0931	1	CONN COAX CBL MTG CONNEX #A2J30
W920	1250-0931	1	CONN COAX CBL MTG CONNEX #A1J10
	03730-70016	1	ASSY COAX CBL BRN/BLU
W921	1250-0931	1	CONN COAX CBL MTG CONNEX #A2J20
	03730-70017	1	ASSY COAX CBL BRN/VIO
W922	1251-3040	1	CONN MULTIE CANNON #FLOA/TING# #J30
	1251-2457	1	CONN COAX CBL MTG CANNON #P/D J30
W923	03730-70018	1	ASSY COAX CBL BRN/GRY
	1251-0931	1	CONN COAX CBL MTG CONNEX #A1J30
W924	03730-70024	1	ASSY CBL #510

Ref Desig	HP Part No	TQ	Description
X43	1251-0172	3	CONN MULTIE SHD MTG 22-WAY
	1251-0172		CONN MULTIE SHD MTG 22-WAY
	1251-0172		CONN MULTIE SHD MTG 22-WAY
Z1	8453A-010	1	ATTEN 100%
ZZ1	9211-0249	1	CARTON CORRUGATED
	9223-0043	1	POST POLYETHYLENE #1040
A1	03730-70001	1	ASSY DISCRIMINATOR
	03730-30001	1	PC BD BLANK
A1C1	0150-0050	37	C FXD 1000PF +90-20% 1000WVDC
	0150-0050		C FXD 1000PF +90-20% 1000WVDC
			NOT ASSIGNED
			NOT ASSIGNED
			NOT ASSIGNED
A1C4	0150-0050		C FXD 1000PF +90-20% 1000WVDC
			NOT ASSIGNED
A1C7	0150-0050		C FXD 1000PF +90-20% 1000WVDC
			NOT ASSIGNED
	0150-0050		C FXD 1000PF +90-20% 1000WVDC
	0150-0050		C FXD 1000PF +90-20% 1000WVDC
	0150-0050		C FXD 1000PF +90-20% 1000WVDC
A1C11	0150-0050		C FXD 1000PF +90-20% 1000WVDC
	0150-0050		C FXD 1000PF +90-20% 1000WVDC
	0150-0050		C FXD 1000PF +90-20% 1000WVDC
	0150-0050		C FXD 1000PF +90-20% 1000WVDC
	0150-0050		C FXD 1000PF +90-20% 1000WVDC
A1C14	0150-0050		C FXD 1000PF +90-20% 1000WVDC
	0150-0050		C FXD 1000PF +90-20% 1000WVDC
	0150-0050		C FXD 1000PF +90-20% 1000WVDC
	0150-0050		C FXD 1000PF +90-20% 1000WVDC
	0150-0050		C FXD 1000PF +90-20% 1000WVDC
A1C16	0150-0050		C FXD 1000PF +90-20% 1000WVDC
	0140-2498	1	C FXD 100PF 0.25PF 500WVDC
	0150-0050		C FXD 1000PF +90-20% 1000WVDC
			NOT ASSIGNED
			C FXD 50PF 5% 500WVDC
A1C21	0160-3834	1	C FXD 50PF 5% 500WVDC
	0160-2257	1	C FXD 10PF 5% 500WVDC
	0150-0050		C FXD 1000PF +90-20% 1000WVDC
	0160-0155	15	C FXD 2.2UF 20% 200WVDC
	0150-0050		C FXD 1000PF +90-20% 1000WVDC
A1C25	0160-0301	1	C FXD 0.012UF 10% 200WVDC
	0160-2230	1	C FXD 3300PF 5% 300WVDC
A1C27	0150-0050		C FXD 1000PF +90-20% 1000WVDC
	0150-0050		C FXD 1000PF +90-20% 1000WVDC
	0150-0050		C FXD 1000PF +90-20% 1000WVDC
	0150-0050		C FXD 1000PF +90-20% 1000WVDC
	0150-0050		C FXD 1000PF +90-20% 1000WVDC
A1C41	1401-0442	1	DIO 51
	1402-0793	2	DIO BRDM 11.7V 500M
	1401-0518	1	DIO NOT CARRIER
	1402-0793		DIO BRDM 11.7V 500M
A1J1	1250-0932	7	CONN COAX PC BD MTG CONNEX
	1250-0932		CONN COAX PC BD MTG CONNEX
A1L1	9140-0105	2	IND FXD 6.2UM 10%
	9100-1624	1	IND FXD 50UM 5%
	9100-1632	1	IND FXD 62UM 5%
	9140-0105		IND FXD 6.2UM 10%
	9100-1629	1	IND FXD 33UM 5%
A1M1	1820-0143	1	IC FLIP-FLCP JK
	1820-0102	3	IC FLIP-FLCP JK
	1820-0102		IC FLIP-FLCP JK
	1820-0102		IC FLIP-FLCP JK

Abbreviations are listed in the introduction to this section

Table 5-1 Replaceable Parts (continued)

Ref Desig	HP Part No	TQ	Description
A1C1	1854-0048	4	XSTR 51 NPN
A1C2	1854-0048		XSTR 51 NPN
A1C3	1854-0048		XSTR 51 NPN
A1C4	1854-0048		XSTR 51 NPN
A1C5	1854-0019	8	XSTR 51 NPN
A1C6	1854-0019		XSTR 51 NPN
A1C7	1854-0019		XSTR 51 NPN
A1C8	1854-0019		XSTR 51 NPN
A1C9	1854-0019		XSTR 51 NPN
A1C10	1854-0019		XSTR 51 NPN
A1C11	1853-0034	1	XSTR 51 PNP
A1C12	1854-0019		XSTR 51 NPN
A1C13	1854-0035		XSTR 51 NPN
A1R1	0757-0276	1	R FXD 61.8 OHM 1% 1/8W
A1R2	0757-0461	12	R FXD 100 OHM 1% 1/8W
A1R3	0757-0274	1	R FXD 1.21K OHM 1% 1/8W
A1R4	0698-3447	1	R FXD 422 OHM 1% 1/8W
A1R5	0757-0416	5	R FXD 511 OHM 1% 1/8W
A1R6	0757-0428	4	R FXD 1.62K OHM 1% 1/8W
A1R7			NOT ASSIGNED
A1R8			NOT ASSIGNED
A1R9			NOT ASSIGNED
A1R1C	0757-0284	5	R FXD 150 OHM 1% 1/8W
A1R11	0757-0401		R FXD 100 OHM 1% 1/8W
A1R12	0757-0427	1	R FXD 1.5K OHM 1% 1/8W
A1R13	0757-0401		R FXD 100 OHM 1% 1/8W
A1R14	0757-0284		R FXD 150 OHM 1% 1/8W
A1R15	0757-0284		R FXD 150 OHM 1% 1/8W
A1R16	0757-0471		R FXD 100 OHM 1% 1/8W
A1R17	0757-0338	2	R FXD 1K OHM 1% 1/8W
A1R18	0757-0401		R FXD 100 OHM 1% 1/8W
A1R19	0698-3132	1	R FXD 261 OHM 1% 1/8W
A1R2C	0757-0401		R FXD 100 OHM 1% 1/8W
A1R21	0757-0317	1	R FXD 1.33K OHM 1% 1/8W
A1R22	0757-0401		R FXD 100 OHM 1% 1/8W
A1R23	0757-0401		R FXD 100 OHM 1% 1/8W
A1R24	0757-0416		R FXD 511 OHM 1% 1/8W
A1R25	0698-3132	2	R FXD 261 OHM 1% 1/8W
A1R26	0698-5490	2	R FXD 2K OHM 1% 1/8W
A1R27	0757-0401		R FXD 100 OHM 1% 1/8W
A1R28	0757-0416		R FXD 511 OHM 1% 1/8W
A1R29			NOT ASSIGNED
A1R30	0757-0442	7	R FXD 10K OHM 1% 1/8W
A1R31	0757-0442		R FXD 10K OHM 1% 1/8W
A1R32	0757-0279	3	R FXD 3.16K OHM 1% 1/8W
A1R33	0757-0401		R FXD 100 OHM 1% 1/8W
A1R34	0757-0416	1	R FXD 619 OHM 1% 1/8W
A1R35	0698-3437	2	R FXD 133 OHM 1% 1/8W
A1R36	0757-0401		R FXD 100 OHM 1% 1/8W
A1R37	0757-0338		R FXD 1K OHM 1% 1/8W
A1R38	0757-0401		R FXD 100 OHM 1% 1/8W
A1R39	0698-3444	1	R FXD 316 OHM 1% 1/8W
A2	03130-700C2	1	ASSY IF AMPLIFIER
	03130-300C2	1	PC BD BLANK

Ref Desig	HP Part No	TQ	Description
A2C1	0121-0081	1	C VAR 5.5-18PF 30WVDC
A2C2	0150-0093	3	C FXD 0.01UF +80-10% 100WVDC
A2C3	0180-0155		C FXD 2.2UF 20% 20WVDC
A2C4	0180-0155		C FXD 2.2UF 20% 20WVDC
A2C5	0180-0155		C FXD 2.2UF 20% 20WVDC
A2C6	0180-0155		C FXD 2.2UF 20% 20WVDC
A2C7	0180-0155		C FXD 2.2UF 20% 20WVDC
A2C8	0180-0155		C FXD 2.2UF 20% 20WVDC
A2C9	0150-0050		C FXD 1000PF +80-20% 1000WVDC
A2C10	0150-0050		C FXD 1000PF +80-20% 1000WVDC
A2C11	0150-0050		C FXD 1000PF +80-20% 1000WVDC
A2C12	0180-0429	1	C FXD 6.8PF 5% 30WVDC
A2C13	0150-0050		C FXD 1000PF +80-20% 1000WVDC
A2C14	0150-0050		C FXD 1000PF +80-20% 1000WVDC
A2C15	0150-0093		C FXD 0.01UF +80-10% 100WVDC
A2C16	0180-0155		C FXD 2.2UF 20% 20WVDC
A2C17	0180-0155		C FXD 2.2UF 20% 20WVDC
A2C18	0180-0155		C FXD 2.2UF 20% 20WVDC
A2C19	0180-0155		C FXD 2.2UF 20% 20WVDC
A2C20	0150-0050		C FXD 1000PF +80-20% 1000WVDC
A2C21	0150-0050		C FXD 1000PF +80-20% 1000WVDC
A2C22	0150-0050		C FXD 1000PF +80-20% 1000WVDC
A2C23	0150-0050		C FXD 1000PF +80-20% 1000WVDC
A2C24	0150-0050		C FXD 1000PF +80-20% 1000WVDC
A2C25	0150-0050		C FXD 1000PF +80-20% 1000WVDC
A2C26	0150-0050		C FXD 1000PF +80-20% 1000WVDC
A2C27	0180-0155		C FXD 2.2UF 20% 20WVDC
A2C28	0180-0155		C FXD 2.2UF 20% 20WVDC
A2C29	0180-0155		C FXD 2.2UF 20% 20WVDC
A2C30	0180-0155		C FXD 2.2UF 20% 20WVDC
A2C31	0150-0050		C FXD 1000PF +80-20% 1000WVDC
A2C32	0150-0050		C FXD 1000PF +80-20% 1000WVDC
A2C33	0150-0050		C FXD 1000PF +80-20% 1000WVDC
A2C34	0150-0050		C FXD 1000PF +80-20% 1000WVDC
A2C35	0150-0050		C FXD 1000PF +80-20% 1000WVDC
A2C36	0150-0050		C FXD 1000PF +80-20% 1000WVDC
A2C37	0150-0050		C FXD 1000PF +80-20% 1000WVDC
A2C38	0121-0402	1	C VAR 1.4-9PF 50WVDC
A2J1	1250-1255	1	CONN COAR PC BD PTC CONNER 50 OHM
A2J2	1250-0932		CONN COAR PC BD PTC CONNER
A2J3	1250-0932		CONN COAR PC BD PTC CONNER
A2J4	1250-0932		CONN COAR PC BD PTC CONNER
A2L1	9140-0144	1	INC FXD 4.7UH 10%
A2L2	03701-739	1	IND VAR
A2Q1	1854-0325	1	XSTR 51 NPN
A2Q2	1854-0323	2	XSTR 51 NPN
A2Q3	1854-0323		XSTR 51 NPN
A2Q4	1854-0233	3	XSTR 51 NPN
A2Q5	1854-0233		XSTR 51 NPN
A2Q6	1854-0233		XSTR 51 NPN
A2Q7	1854-0378	1	XSTR 51 NPN
A2Q8	1854-0092	1	XSTR 51 NPN
A2P1	0698-3435	1	R FXD 36.3 OHM 1% 1/8W

Abbreviations are listed in the introduction to this section

Table 5-1 Replaceable Parts (continued)

Ref Desig	HP Part No	TQ	Description
A2R2	0757-0280	6	R FXD 1K OHM 1% 1/8W
A2R3	0698-0082	1	R FXD 484 OHM 1% 1/8W
A2R4	0757-0280	1	R FXD 1K OHM 1% 1/8W
A2R5	0757-0417	5	R FXD 562 OHM 1% 1/8W
A2R6	0757-0280		R FXD 1K OHM 1% 1/8W
A2R7	0757-0417		R FXD 562 OHM 1% 1/8W
A2R8	0757-0280		R FXD 1K OHM 1% 1/8W
A2R9	0757-0403	1	R FXD 121 OHM 1% 1/8W
A2R10	0757-0417		R FXD 562 OHM 1% 1/8W
A2R11	0757-0284		R FXD 5% NOM VAL 150 OHM 1% 1/8W
A2R12	0698-3315	1	R FXD 330 OHM 5% 1W
A2R13			R FXD 5% FROM 0498-8399 120 OHM 0498-8400 150 OHM 0498-8401 140 OHM 0498-8402 150 OHM 0498-8403 160 OHM
A2R14	0757-0398	1	R FXD 75 OHM 1% 1/4W
A2R15	0698-2215	1	R FXD 220 OHM 5% 1W
A2R16	0757-0710	1	R FXD 75 OHM 1% 1/4W
A2R17	0698-3430	9	R FXD 21.5 OHM 1% 1/8W
A2R18	0757-0280		R FXD 1K OHM 1% 1/8W
A2R19	0757-0199	1	R FXD 21.5K OHM 1% 1/8W
A2R20	0698-3441	2	R FXD 215 OHM 1% 1/8W
A2R21	0757-0397	1	R FXD 68.1 OHM 1% 1/8W
A2R22	0757-0346	7	R FXD 10 OHM 1% 1/8W
A2R23	0757-0346		R FXD 10 OHM 1% 1/8W
A2R24	0757-0346		R FXD 10 OHM 1% 1/8W
A2R25	0698-3430		R FXD 21.5 OHM 1% 1/8W
A2R26	0698-3430		R FXD 21.5 OHM 1% 1/8W
A2R27	0698-3430		R FXD 21.5 OHM 1% 1/8W
A2R28	0698-3430		R FXD 21.5 OHM 1% 1/8W
A2R29	0698-3132		R FXD 243 OHM 1% 1/8W
A2R30	0698-3204	1	R FXD 178 OHM 1% 1/4W
A2R31	0757-0316	1	R FXD 42.2 OHM 1% 1/8W
A2R32	0757-0346		R FXD 10 OHM 1% 1/8W
A2R33	0757-0346		R FXD 10 OHM 1% 1/8W
A2R34	0757-0346		R FXD 10 OHM 1% 1/8W
A2R35	0698-0084	3	R FXD 2.15K OHM 1% 1/8W
A2R36	0698-3430		R FXD 21.5 OHM 1% 1/8W
A2R37	0698-3430		R FXD 21.5 OHM 1% 1/8W
A2R38	0698-3430		R FXD 21.5 OHM 1% 1/8W
A2R39	0698-3441		R FXD 215 OHM 1% 1/8W
A2R40	0698-3430		R FXD 21.5 OHM 1% 1/8W
A2R41	0757-0346		R FXD 10 OHM 1% 1/8W
A2T1	03701-735	6	XFMR
A2T2	03701-735		XFMR
A2T3	03701-735		XFMR
A2T4	03701-735		XFMR
A2T5	03701-735		XFMR
A2T6	03701-735	2	XFMR
A2T7	03701-738		XFMR
A2T8	03701-738		XFMR
A3	03730-700C3	1	ASSY LOOP AMPLIFIER
	03730-30CC3	1	PC BD BLANK
	4C40-0748	3	EXTRACTOR PC BD BLK

Ref Desig	HP Part No	TQ	Description
	4C40-0751	1	EXTRACTOR PC BD CM
A3C1	0160-3886	2	C FIC 2.2UF 1% 63VDC
A3C2	0160-3885	2	C FXD 10UF 1% 63VDC
A3C3	0160-0174	1	C FXD 0.47UF +80-20% 250VDC
A3C4	0160-3885		C FXD 10UF 1% 63VDC
A3C5	0160-3886		C FXD 2.2UF 1% 63VDC
A3C6	0180-0374	1	C FXD 10UF 1% 20VDC
A3C7	0150-0093		C FXD 0.01UF +80-10% 100VDC
A3C8	0150-0093		C FXD 0.01UF +80-10% 100VDC
A3C9	0150-0093		C FXD 0.01UF +80-10% 100VDC
A3C11	1902-3059	1	DIO BRDM 3.63V 5% 400mW
A3C12	1902-0680	3	DIO BRDM 6.2V 5% 400mW
A3C1	1854-0221	7	XSTR 5% NPA DUAL
A3C2	1854-0071	7	XSTR 5% NPA
A3C3	1854-0221		XSTR 5% NPA DUAL
A3C4	1854-0071		XSTR 5% NPA
A3C5	1853-0050	2	XSTR 5% PNP
A3C6	1853-0050		XSTR 5% PNP
A3C7	1854-0071		XSTR 5% NPA
A3C8	1854-0221		XSTR 5% NPA DUAL
A3C9			NOT ASSIGNED
A3C10	1854-0221		XSTR 5% NPA DUAL
A3C11	1853-0036	2	XSTR 5% PNP
A3C12	1854-0071		XSTR 5% NPA
A3C13	1853-0036		XSTR 5% PNP
A3R1	0757-0444	9	R FXD 12.1K OHM 1% 1/8W
A3R2	0698-3450	4	R FXD 42.2K OHM 1% 1/8W
A3R3	0757-0279		R FXD 3.16K OHM 1% 1/8W
A3R4	0757-0444	3	R FXD 7.9K OHM 1% 1/8W
A3R5	0698-3450		R FXD 42.2K OHM 1% 1/8W
A3R6	0757-0279		R FXD 3.16K OHM 1% 1/8W
A3R7	0757-0444		R FXD 12.1K OHM 1% 1/8W
A3R8	0698-0083	1	R FXD 1.96K OHM 1% 1/8W
A3R9	0698-3450		R FXD 42.2K OHM 1% 1/8W
A3R10	0757-0290	3	R FXD 6.19K OHM 1% 1/8W
A3R11	0757-0444		R FXD 12.1K OHM 1% 1/8W
A3R12	0698-3450		R FXD 42.2K OHM 1% 1/8W
A3R13	0757-0290		R FXD 6.19K OHM 1% 1/8W
A3R14	0757-0443	1	R FXD 11K OHM 1% 1/8W
A3R15	0757-0470		R FXD 1.62K OHM 1% 1/8W
A3R16	0757-0444		R FXD 12.1K OHM 1% 1/8W
A3R17	0757-0278	1	R FXD 1.78K OHM 1% 1/8W
A3R18	0757-0428		R FXD 1.62K OHM 1% 1/8W
A3R19	0757-0444		R FXD 12.1K OHM 1% 1/8W
A3R20	0757-0442		R FXD 10K OHM 1% 1/8W
A3R21	0757-0433	1	R FXD 3.32K OHM 1% 1/8W
A3R22	0757-0438	7	R FXD 5.11K OHM 1% 1/8W
A3R23	0757-0444		R FXD 12.1K OHM 1% 1/8W
A3R24	0757-0424	4	R FXD 1.1K OHM 1% 1/8W
A3R25	0757-0416		R FXD 511 OHM 1% 1/8W
A3R26	2100-2652	1	R VAR 100 OHM 10% 1/2W
A3R27	0757-0290		R FXD 6.19K OHM 1% 1/8W
A3R28	0757-0424		R FXD 1.1K OHM 1% 1/8W
A3R29	0757-0416		R FXD 511 OHM 1% 1/8W

Abbreviations are listed in the introduction to this section

Table 5-1 Replaceable Parts (continued)

Ref Desig	HP Part No	TQ	Description
A3R30	0757-0444		R FXD 12.1K OHM 1% 1/8W
A3R31			NOT ASSIGNED
A3R32	2100-2413	1	R VAR 200 OHM 10% 1/2W
A3R33	C498-3437		R FXD 133 OHM 1% 1/8W
A3R34	0757-0428		R FXD 1.62K OHM 1% 1/8W
A3R35	0757-0417		R FXD 562 OHM 1% 1/8W
A3R36	0698-5490		R FXD 2K OHM 1% 1/8W
A3R37	C498-3159	1	R FXD 26.1K OHM 1% 1/8W
A3R38	0757-0438		R FXD 5.11K OHM 1% 1/8W
A3R39	0757-0439	3	R FXD 6.81K OHM 1% 1/8W
A3R40	0757-0442		R FXD 10K OHM 1% 1/8W
A3R41	0698-3155	1	R FXD 4.44K OHM 1% 1/8W
A3R42	2100-2574	1	R VAR 500 OHM 10% 1/2W
A3R43			NOT ASSIGNED
A3R44	0757-0438		R FXD 5.11K OHM 1% 1/8W
A3R45	0757-0449	1	R FXD 20K OHM 1% 1/8W
A3R46	0757-0442		R FXD 10K OHM 1% 1/8W
A3R47	0757-0280		R FXD 1K OHM 1% 1/8W
A3R48	0757-0438		R FXD 5.11K OHM 1% 1/8W
A4	03730-70004	1	ASSY RECTIFIER
	C3730-30004	1	PC BD BLANK
	4C40-0748		EXTRACTOR PC BD BLK
	4C40-0752	1	EXTRACTOR PC BD YEL
A4CR1	1901-0416	1	DIC SI
A4CR2	1901-0416	1A	DIO SI 200PIV 3A
A4CR3	1901-0416		DIO SI 200PIV 3A
A4CR4	1901-0416		DIO SI 200PIV 3A
A4CR5	1901-0416		DIO SI 200PIV 3A
A4CR6	1901-0416		DIO SI 200PIV 3A
A4CR7	1901-0416		DIO SI 200PIV 3A
A4CR8	1901-0416		DIO SI 200PIV 3A
A4CR9	1901-0416		DIO SI 200PIV 3A
A4CR10	1901-0416		DIO SI 200PIV 3A
A4CR11	1901-0416		DIO SI 200PIV 3A
A4CR12	1901-0416		DIO SI 200PIV 3A
A4CR13	1901-0416		DIO SI 200PIV 3A
A4CR14	1901-0416		DIO SI 200PIV 3A
A4CR15	1901-0416		DIO SI 200PIV 3A
A4CR16	1901-0416		DIO SI 200PIV 3A
A4CR17	1901-0416		DIO SI 200PIV 3A
A4R1	0757-0853	1	R FXD 51.1K OHM 1% 1/2W
A4R2	0757-0446	4	R FXD 15K OHM 1% 1/8W
A4R3	0757-0446		R FXD 15K OHM 1% 1/8W
A4R4	0757-0446		R FXD 15K OHM 1% 1/8W
A4R5	0757-0446		R FXD 15K OHM 1% 1/8W
A5	03730-70005	1	ASSY REGULATOR
	C3730-30005	1	PC BD BLANK
	4C40-0748		EXTRACTOR PC BD BLK
	4C40-0753	1	EXTRACTOR PC BD GRN
ASC1	0180-0089	2	C FXD 10UF +50-10% 150WVDC
ASC2	0180-2225	2	C FXD 2000PF 5% 300WVDC
ASC3	0180-0228	3	C FXD 22UF 10% 15WVDC
ASC4	0180-0097	3	C FXD 47UF 10% 35WVDC
ASC5	0180-0089		C FXD 10UF +50-10% 150WVDC

Ref Desig	HP Part No	TQ	Description
ASC6	0169-2225		C FXD 2000PF 5% 300WVDC
ASC7	0180-0228		C FXD 22UF 10% 15WVDC
ASC8	0180-0097		C FXD 47UF 10% 35WVDC
ASC9	0180-0228		C FXD 22UF 10% 15WVDC
ASC10			NOT ASSIGNED
ASC11	0180-0097		C FXD 47UF 10% 35WVDC
ASC12	1902-0175	1	DIC BRDN 100V 5% 1W
ASC13	1902-0680		DIC BRDN 6.2V 5% 400mW
ASC14	1902-3104	1	DIO BRDN 5.62V 5% 400mW
ASC15	1902-0680		DIC BRDN 6.2V 5% 400mW
ASC16	1902-0784	1	DIO BRDN 9V 5% 400mW
ASC17			
ASC18	1910-0003	1	DIC GE
ASQ1	1854-CC39	3	XSTR SI NPN
ASQ2	1705-0011	3	HEAT DISSIPATOR XSTR
ASQ3	1854-CC71		XSTR SI NPN
ASQ4	1854-0221		XSTR SI NPN DUAL
ASQ5	1854-0039		XSTR SI NPN
ASQ6	1205-0011		HEAT DISSIPATOR XSTR
ASQ7	1854-CC71		XSTR SI NPN
ASQ8	1854-0221		XSTR SI NPN DUAL
ASQ9	1854-0039		XSTR SI NPN
ASQ10	1205-0011		HEAT DISSIPATOR XSTR
ASQ11	1854-CC71		XSTR SI NPN
ASQ12	1854-0221		XSTR SI NPN DUAL
ASQ13	1854-0039		XSTR SI NPN
ASQ14	1205-0011		HEAT DISSIPATOR XSTR
ASQ15	1854-CC71		XSTR SI NPN
ASQ16	1854-0221		XSTR SI NPN DUAL
ASQ17	1854-0039		XSTR SI NPN
ASQ18	1205-0011		HEAT DISSIPATOR XSTR
ASQ19	1854-CC71		XSTR SI NPN
ASQ20	1854-0221		XSTR SI NPN DUAL
ASQ21	1854-0039		XSTR SI NPN
ASQ22	1205-0011		HEAT DISSIPATOR XSTR
ASQ23	1854-CC71		XSTR SI NPN
ASQ24	1854-0221		XSTR SI NPN DUAL
ASQ25	1854-0039		XSTR SI NPN
ASQ26	1205-0011		HEAT DISSIPATOR XSTR
ASQ27	1854-CC71		XSTR SI NPN
ASQ28	1854-0221		XSTR SI NPN DUAL
ASQ29	1854-0039		XSTR SI NPN
ASQ30	1205-0011		HEAT DISSIPATOR XSTR
ASQ31	1854-CC71		XSTR SI NPN
ASQ32	1854-0221		XSTR SI NPN DUAL
ASQ33	1854-0039		XSTR SI NPN
ASQ34	1205-0011		HEAT DISSIPATOR XSTR
ASQ35	1854-CC71		XSTR SI NPN
ASQ36	1854-0221		XSTR SI NPN DUAL
ASQ37	1854-0039		XSTR SI NPN
ASQ38	1205-0011		HEAT DISSIPATOR XSTR
ASQ39	1854-CC71		XSTR SI NPN
ASQ40	1854-0221		XSTR SI NPN DUAL
ASQ41	1854-0039		XSTR SI NPN
ASQ42	1205-0011		HEAT DISSIPATOR XSTR
ASQ43	1854-CC71		XSTR SI NPN
ASQ44	1854-0221		XSTR SI NPN DUAL
ASQ45	1854-0039		XSTR SI NPN
ASQ46	1205-0011		HEAT DISSIPATOR XSTR
ASQ47	1854-CC71		XSTR SI NPN
ASQ48	1854-0221		XSTR SI NPN DUAL
ASQ49	1854-0039		XSTR SI NPN
ASQ50	1205-0011		HEAT DISSIPATOR XSTR
ASQ51	1854-CC71		XSTR SI NPN
ASQ52	1854-0221		XSTR SI NPN DUAL
ASQ53	1854-0039		XSTR SI NPN
ASQ54	1205-0011		HEAT DISSIPATOR XSTR
ASQ55	1854-CC71		XSTR SI NPN
ASQ56	1854-0221		XSTR SI NPN DUAL
ASQ57	1854-0039		XSTR SI NPN
ASQ58	1205-0011		HEAT DISSIPATOR XSTR
ASQ59	1854-CC71		XSTR SI NPN
ASQ60	1854-0221		XSTR SI NPN DUAL
ASQ61	1854-0039		XSTR SI NPN
ASQ62	1205-0011		HEAT DISSIPATOR XSTR
ASQ63	1854-CC71		XSTR SI NPN
ASQ64	1854-0221		XSTR SI NPN DUAL
ASQ65	1854-0039		XSTR SI NPN
ASQ66	1205-0011		HEAT DISSIPATOR XSTR
ASQ67	1854-CC71		XSTR SI NPN
ASQ68	1854-0221		XSTR SI NPN DUAL
ASQ69	1854-0039		XSTR SI NPN
ASQ70	1205-0011		HEAT DISSIPATOR XSTR
ASQ71	1854-CC71		XSTR SI NPN
ASQ72	1854-0221		XSTR SI NPN DUAL
ASQ73	1854-0039		XSTR SI NPN
ASQ74	1205-0011		HEAT DISSIPATOR XSTR
ASQ75	1854-CC71		XSTR SI NPN
ASQ76	1854-0221		XSTR SI NPN DUAL
ASQ77	1854-0039		XSTR SI NPN
ASQ78	1205-0011		HEAT DISSIPATOR XSTR
ASQ79	1854-CC71		XSTR SI NPN
ASQ80	1854-0221		XSTR SI NPN DUAL
ASQ81	1854-0039		XSTR SI NPN
ASQ82	1205-0011		HEAT DISSIPATOR XSTR
ASQ83	1854-CC71		XSTR SI NPN
ASQ84	1854-0221		XSTR SI NPN DUAL
ASQ85	1854-0039		XSTR SI NPN
ASQ86	1205-0011		HEAT DISSIPATOR XSTR
ASQ87	1854-CC71		XSTR SI NPN
ASQ88	1854-0221		XSTR SI NPN DUAL
ASQ89	1854-0039		XSTR SI NPN
ASQ90	1205-0011		HEAT DISSIPATOR XSTR
ASQ91	1854-CC71		XSTR SI NPN
ASQ92	1854-0221		XSTR SI NPN DUAL
ASQ93	1854-0039		XSTR SI NPN
ASQ94	1205-0011		HEAT DISSIPATOR XSTR
ASQ95	1854-CC71		XSTR SI NPN
ASQ96	1854-0221		XSTR SI NPN DUAL
ASQ97	1854-0039		XSTR SI NPN
ASQ98	1205-0011		HEAT DISSIPATOR XSTR
ASQ99	1854-CC71		XSTR SI NPN
ASQ100	1854-0221		XSTR SI NPN DUAL

Abbreviations are listed in the introduction to this section

Table 5-1 Replaceable Parts (continued)

Ref Desig	HP Part No	TQ	Description
ASR2C	2100-2633		R VAR 1K 10E 1/2W LIN
ASR21	0757-0200	1	R FXD 5.62K OHM 1% 1/8W
ASR22	0698-0088	1	R FXD 215 OHM 1% 1/4W
ASR23	0757-0482	2	R FXD 75K OHM 1% 1/8W
ASR24	0757-0482		R FXD 75K OHM 1% 1/8W
AB	C373C-70016	1	ASSY GROUP DELAY EQUALISER
	03730-30036	1	PC BD BLANK
ABC1	0121-0060	1	C VAR 2-8PF 300VDC
ABC2	0180-0699	1	C FXD 30PF 5% 350VDC
ABC3	0121-0046	1	C VAR 9-35PF
ABJ1	1250-0932		CONN COAX PC BD PTG CONNEX
ABJ2	1250-0932		CONN COAX PC BC PTG CONNEX
ABL1	C3701-730	1	IND VAR
ABL2	C3702-725	1	IND VAR

Ref Desig	HP Part No	TQ	Description
			OPTICH 002 SIEMENS 2.5MM IF O/P CONN
			USE STANDARD REPLACEABLE PARTS LIST WITH THE FOLLOWING REPLACEMENTS
MP1	03730-10027	1	PAL FRONT LT REPLACES 03730-100010
W011	03730-70042	1	ASSY COAX CAB BRN/BRN REPLACES 03730-700110
	1250-1083	1	CONN SIEMENS 2.5MM #J10 REPLACES 1250-06104
			OPTICH 003 SIEMENS 1.6MM IF O/P CONN
			USE STANDARD REPLACEABLE PARTS LIST WITH THE FOLLOWING REPLACEMENTS
MP1	03730-10029	1	PAL FRONT LT REPLACES 03730-100010
W011	03730-70043	1	ASSY COAX CAB BRN/BRN REPLACES 03730-700110
	1250-1077	1	CONN SIEMENS 1.6MM #J10 REPLACES 1250-06104
			OPTICH 004 NECO IF O/P CONN
			USE STANDARD REPLACEABLE PARTS LIST WITH THE FOLLOWING REPLACEMENTS AND ADDITIONS
MP1	03730-10031	1	PAL FRONT LT REPLACES 03730-100010
	03730-10033	1	PAL SLB LT REPLACES 03730-100020
	01730-30016	1	AKT CONN BECC
W011	03730-70045	1	ASSY COAX CAB BRN/BRN REPLACES 03730-700110
	1250-0652	1	CONN NECO #J10 REPLACES 1250-06104

Abbreviations are listed in the introduction to this section

Table 5-1 Replaceable Parts (continued)

Ref Desig	HP Part No	TQ	Description
			OPTIC 010 250B AMPLIFIER AND 250B ATTENUATOR
			USE STANDARD REPLACEABLE PARTS LIST WITH THE FOLLOWING REPLACEMENTS AND ADDITIONS
HP1	03730-10021	1	PNL FRONT LF *REPLACES 03150-10001F
	03730-10020	1	BRT ATTEN COVER DUST-UNUSEC CONN #102B
W920	03730-70020	1	ASSY COAR CBL RED/BLK *REPLACES 03730-70015B
	1250-0931	4	CONN COAR CBL MTC CONNEX #A7J3B
	1250-0931	4	CONN COAR CBL MTC CONNEX #A1J1B
W922	03730-70022	1	ASSY COAR CBL REC/RED
	1250-0931	4	CONN COAR CBL MTC CONNEX #A2J4B
	03702-348	2	CONN COAR CBL MTC #A8A1J1B
W923	03730-70023	1	ASSY COAR CBL RED/ORN
	03702-348	2	CONN COAR CBL MTC #A8A1J2B
	1250-0931	4	CONN COAR CBL MTC CO-CONN #A7J1B
AT	03730-70007	1	ASSY IF AMPLIFIER
	03730-10007	1	PC BO BLANK
ATC1	0150-0050	1	C FXD 3.3PF 0.25PF 500WVDC
ATC2	0150-0093	2	C FXD 0.01UF +80-20R 1000WVDC
ATC3	0180-0155	14	C FXD 2.2UF 20R 20WVDC
ATC4	0180-0155	14	C FXD 2.2UF 20R 20WVDC
ATC5	0180-0155	14	C FXD 2.2UF 20R 20WVDC
ATC6	0180-0155	14	C FXD 2.2UF 20R 20WVDC
ATC7	0180-0155	14	C FXD 2.2UF 20R 20WVDC
ATC8	0180-0155	14	C FXD 2.2UF 20R 20WVDC
ATC9	0150-0050	10	C FXD 1000PF +80-20R 1000WVDC
ATC10	0150-0050	10	C FXD 1000PF +80-20R 1000WVDC
ATC11	0150-0050	1	C FXD 1000PF +80-20R 1000WVDC
ATC12	0180-0629	1	C FXD 6.8PF 5R 30WVDC
ATC13	0150-0050	1	C FXD 1000PF +80-20R 1000WVDC
ATC14	0150-0050	1	C FXD 1000PF +80-20R 1000WVDC
ATC15	0150-0093	1	C FXD 0.01UF +80-10R 1000WVDC
ATC16	0180-0155	14	C FXD 2.2UF 20R 20WVDC
ATC17	0180-0155	14	C FXD 2.2UF 20R 20WVDC
ATC18	0180-0155	14	C FXD 2.2UF 20R 20WVDC
ATC19	0180-0155	14	C FXD 2.2UF 20R 20WVDC
ATC20	0150-0050	10	C FXD 1000PF +80-20R 1000WVDC
ATC21	0150-0050	10	C FXD 1000PF +80-20R 1000WVDC
ATC22	0150-0050	10	C FXD 1000PF +80-20R 1000WVDC
ATC23	0150-0050	10	C FXD 1000PF +80-20R 1000WVDC
ATC24	0150-0050	10	C FXD 1000PF +80-20R 1000WVDC
ATC25	0150-0050	10	C FXD 1000PF +80-20R 1000WVDC
ATC26	0150-0050	10	C FXD 1000PF +80-20R 1000WVDC
ATC27	0180-0155	14	C FXD 2.2UF 20R 20WVDC
ATC28	0180-0155	14	C FXD 2.2UF 20R 20WVDC
ATC29	0180-0155	14	C FXD 2.2UF 20R 20WVDC
ATC30	0180-0155	14	C FXD 2.2UF 20R 20WVDC

Ref Desig	HP Part No	TQ	Description
ATC31	0150-0050	10	C FXD 1000PF +80-20R 1000WVDC
ATC32	0150-0050	10	C FXD 1000PF +80-20R 1000WVDC
ATC33	0150-0050	10	C FXD 1000PF +80-20R 1000WVDC
ATC34	0150-0050	10	C FXD 1000PF +80-20R 1000WVDC
ATC35	0150-0050	10	C FXD 1000PF +80-20R 1000WVDC
ATC36	0150-0050	10	C FXD 1000PF +80-20R 1000WVDC
ATC37	0150-0050	10	C FXD 1000PF +80-20R 1000WVDC
ATC38	0121-0402	1	C VAR 1.4-9PF 50WVDC
ATJ1	1250-0932	4	CONN COAR PC BC MTC CONNEX
ATJ2	1250-0932	4	CONN COAR PC BC MTC CONNEX
ATJ3	1250-0932	4	CONN COAR PC BC MTC CONNEX
ATJ4	1250-0932	4	CONN COAR PC BC MTC CONNEX
ATL1	9140-0144	1	INC FXD 4.7UH 10R
ATL2	03701-759	1	IND VAR
ATC1	1854-0225	1	RSTR 5R 1/4W
ATC2	1854-0225	2	RSTR 5R 1/4W
ATC3	1854-0225	1	RSTR 5R 1/4W
ATC4	1854-0233	3	RSTR 5R 1/4W
ATC5	1854-0233	3	RSTR 5R 1/4W
ATC6	1854-0578	1	RSTR 5R 1/4W
ATC7	1854-0233	3	RSTR 5R 1/4W
ATC8	1854-0052	1	RSTR 5R 1/4W
ATR1	0757-0397	2	R FXD 68.1 OHM 1R 1/4W
ATR2	0757-0240	5	R FXD 1K OHM 1R 1/4W
ATR3	0698-0082	1	R FXD 44K OHM 1R 1/4W
ATR4	0757-0280	1	R FXD 1K OHM 1R 1/4W
ATR5	0757-0417	3	R FXD 562 OHM 1R 1/4W
ATR6	0757-0280	1	R FXD 1K OHM 1R 1/4W
ATR7	0757-0417	3	R FXD 562 OHM 1R 1/4W
ATR8	0757-0280	1	R FXD 1K OHM 1R 1/4W
ATR9	0757-0403	1	R FXD 12R OHM 1R 1/4W
ATR10	0757-0417	3	R FXD 562 OHM 1R 1/4W
ATR11	0757-0280	1	R FXD 1K OHM 1R 1/4W
ATR12	0689-3315	1	R FXD 330 OHM 5R 1W
ATR13	0689-3315	1	R FXD 330 OHM 5R 1W
			R FXD ST FROM C698-3399 120 OHM
			R FXD ST FROM C698-3400 130 OHM
			R FXD ST FROM C698-3401 140 OHM
			R FXD ST FROM C698-3402 150 OHM
			R FXD ST FROM C698-3403 160 OHM
ATR14	0757-0398	1	R FXD 75 OHM 1R 1/4W
ATR15	0689-2215	1	R FXD 220 OHM 5R 1W
ATR16	0757-0710	1	R FXD 75 OHM 1R 1/4W
ATR17	0698-3430	9	R FXD 21.5 OHM 1R 1/4W
ATR18	0757-0280	1	R FXD 1K OHM 1R 1/4W
ATR19	0757-0199	1	R FXD 21.5K OHM 1R 1/4W
ATR20	0698-3441	2	R FXD 21.5 OHM 1R 1/4W
ATR21	0757-0397	2	R FXD 68.1 OHM 1R 1/4W
ATR22	0757-0346	7	R FXD 10 OHM 1R 1/4W
ATR23	0757-0346	7	R FXD 10 OHM 1R 1/4W
ATR24	0757-0346	7	R FXD 10 OHM 1R 1/4W
ATR25	0698-3430	9	R FXD 21.5 OHM 1R 1/4W
ATR26	0698-3430	9	R FXD 21.5 OHM 1R 1/4W
ATR27	0698-3430	9	R FXD 21.5 OHM 1R 1/4W
ATR28	0698-3430	9	R FXD 21.5 OHM 1R 1/4W
ATR29	0698-3132	1	R FXD 241 OHM 1R 1/4W

Abbreviations are listed in the introduction to this section

Table 5-1 Replaceable Parts (continued)

Ref Desig	HP Part No	TQ	Description
ATR3C	0698-3204	1	R FXD 178 OHM 1% 1/4W
ATR33	0757-0316	1	R FXD 42.2 OHM 1% 1/8W
ATR32	0757-0346		R FXD 10 OHM 1% 1/8W
ATR32	0757-0346		R FXD 10 OHM 1% 1/8W
ATR34	0757-0346		R FXD 10 OHM 1% 1/8W
ATR3C	0698-0084	1	R FXD 2.15K OHM 1% 1/4W
ATR3C	0698-3430		R FXD 21.5 OHM 1% 1/4W
ATR37	0698-3430		R FXD 21.5 OHM 1% 1/4W
ATR38	0698-3430		R FXD 21.5 OHM 1% 1/4W
ATR39	0698-3441		R FXD 215 OHM 1% 1/8W
ATPAC	0698-3430		R FXD 21.5 OHM 1% 1/4W
ATRA1	0757-0346		R FXD 10 OHM 1% 1/8W
AT71	03701-735	4	XFMR
AT72	03701-735		XFMR
AT72	03701-735		XFMR
AT74	03701-735		XFMR
AT75	03701-735		XFMR
AT76	03701-735		XFMR
AT77	03701-738	2	XFMR
AT78	03701-738		XFMR
AB	03730-7003C	1	ASSY IF ATTENUATOR
ARMP1	03730-70031	1	ASSY SCREENED BOX
	03702-1201	1	BOX SCREENING
	03702-329	1	SPACER CAPTIVE #7020
ARA1	03730-70008	1	ASSY PC BO IF ATTENUATOR
	03730-30008	1	PC BO BLANK
ARA1R1	0698-7017	2	R FXD 1.305K OHM 0.5% 1/4W
ARA1R2	0698-7020	1	R FXD 0.6 OHM 0.5% 1/4W
ARA1R3	0698-7017	1	R FXD 1.305K OHM 0.5% 1/4W
ARA1R4	0698-7015	2	R FXD 654 OHM 0.5% 1/4W
ARA1R5	0698-7002	1	R FXD 17.4 OHM 0.5% 1/4W
ARA1R6	0698-7015		R FXD 654 OHM 0.5% 1/4W
ARA1R7	0698-7445	2	R FXD 332 OHM 0.5% 1/4W
ARA1R8	0698-7434	1	R FXD 36 OHM 0.5% 1/4W
ARA1R9	0698-7445		R FXD 332 OHM 0.5% 1/4W
ARA1R10	0698-7441	2	R FXD 174 OHM 0.5% 1/4W
ARA1R11	0698-7438	1	R FXD 79.5 OHM 0.5% 1/4W
ARA1R12	0698-7441		R FXD 174 OHM 0.5% 1/4W
ARA1R13	0698-7009	2	R FXD 144.2 OHM 0.5% 1/4W
ARA1R14	0698-7008	1	R FXD 106.8 OHM 0.5% 1/4W
ARA1R15	0698-7009		R FXD 144.2 OHM 0.5% 1/4W
ARA111	3101-0409	1	ASSY SW 5 PR
	5040-3008	1	KNOB PUSH JADE GRAY NUMERAL 1
	5040-3009	1	KNOB PUSH JADE GRAY NUMERAL 2
	5040-3011	1	KNOB PUSH JADE GRAY NUMERAL 4
	5040-3013	1	KNOB PUSH JADE GRAY NUMERAL 8
	5040-3014	1	KNOB PUSH JADE GRAY NUMERAL 10

Ref Desig	HP Part No	TQ	Description
			WHEN OPTION C02 IS SUPPLIED WITH OPTION 010 USE OPTION 010 REPLACEABLE PARTS LIST WITH THE FOLLOWING CHANGES
MP1	03730-1002A	1	PAL FRONT LT #REPLACES 03730-100210
MP11	03730-70042	1	ASSY COAX CBL BRN/BRN #REPLACES 03730-700110
	1250-1083	1	CONN SIEMENS 2.5MM #310 #REPLACES 1250-06100
			WHEN OPTION 003 IS SUPPLIED WITH OPTION 010 USE OPTION 010 REPLACEABLE PARTS LIST WITH THE FOLLOWING CHANGES
MP1	03730-1003C	1	PAL FRONT LT #REPLACES 03730-100210
MP11	03730-70043	1	ASSY COAX CBL BRN/BRN #REPLACES 03730-700110
	1250-1077	1	CONN SIEMENS 1.6MM #310 #REPLACES 1250-06100
			WHEN OPTION 004 IS SUPPLIED WITH OPTION 010 USE OPTION 010 REPLACEABLE PARTS LIST WITH THE FOLLOWING REPLACEMENTS AND ADDITIONS
MP1	03730-10032	1	PAL FRONT LT #REPLACES 03730-100210
	03730-10033	1	PAL SUB LT #REPLACES 03730-100020
	03730-10034	1	BKT ATTEM #REPLACES 03730-100200
	03730-30016	1	BKT COAX NECC
MP11	03730-70045	1	ASSY COAX CBL BRN/BRN #REPLACES 03730-700110
	1250-0852	1	CONN NECC #310 #REPLACES 1250-06100

Abbreviations are listed in the introduction to this section

SECTION VI SERVICE

6-1 INTRODUCTION

6-2 This section contains sufficient information to enable the user or service engineer to diagnose and repair any faults that may occur in the 3730A.

6-3 Included are details of the theory of operation, troubleshooting, schematics, circuit descriptions, and component and assembly location diagrams. The theory of operation, troubleshooting and

assembly location diagrams are presented in the form of General Service Sheets. Sheet G1 applies to the standard 3730A; Sheet G2 applies to the Option 010 version. Schematics, circuit descriptions, and component location diagrams for the assemblies are presented on Assembly Service Sheets. Except for Assemblies A7 and A8, the circuit descriptions and interconnection information given apply to the standard version of the 3730A.

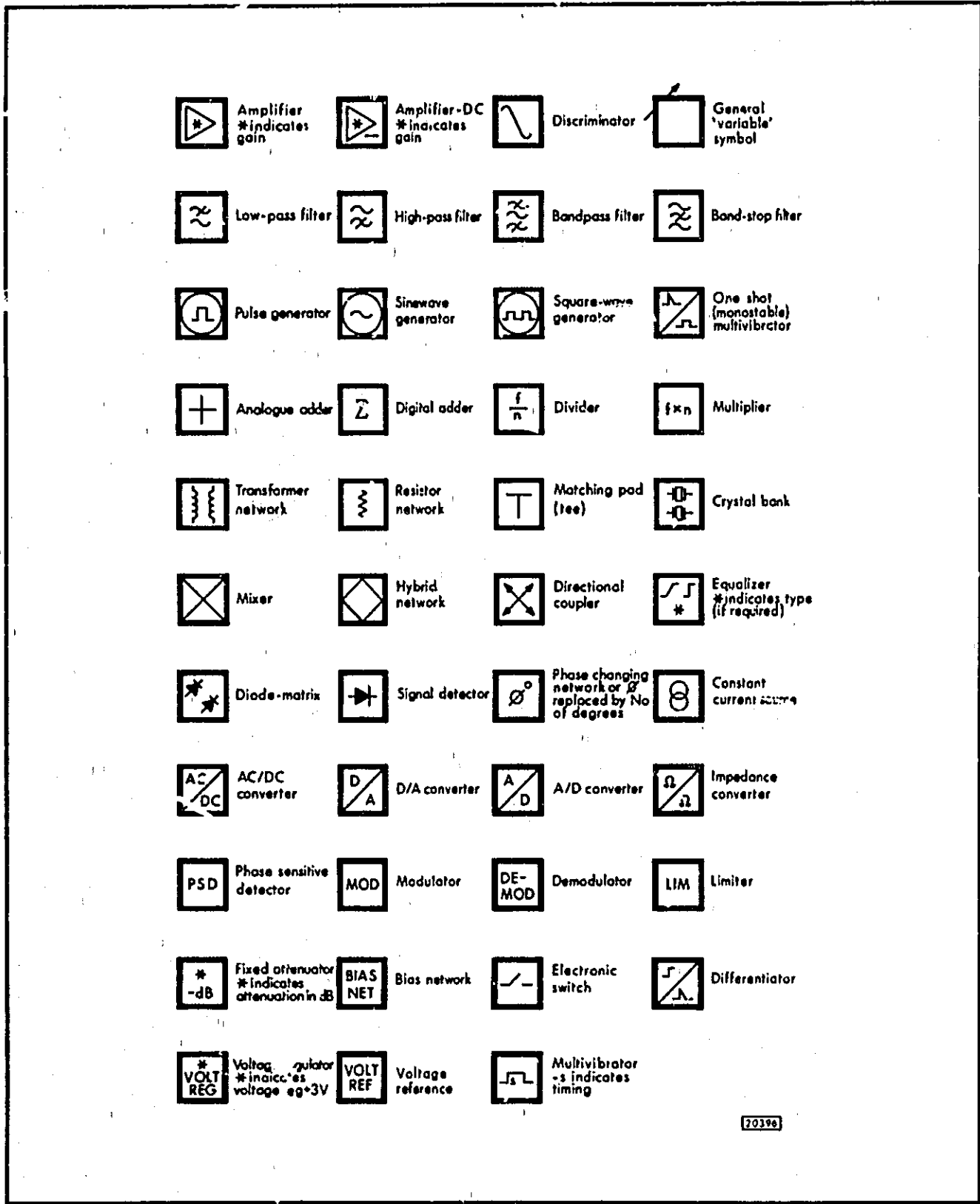

20396

Figure 6-1 Block Diagram Notes

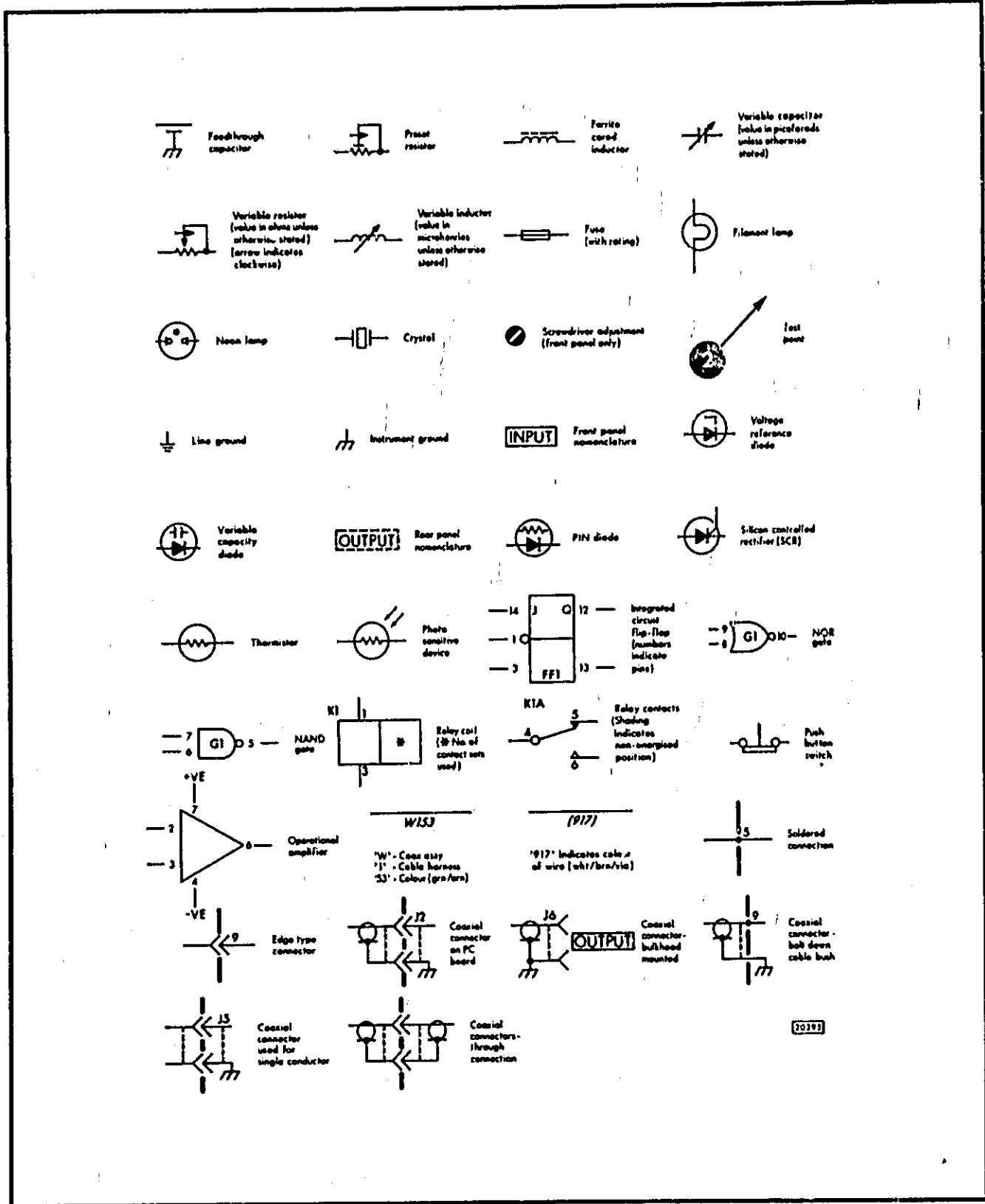

Figure 6-2 Schematic Notes

GENERAL SERVICE SHEET G1

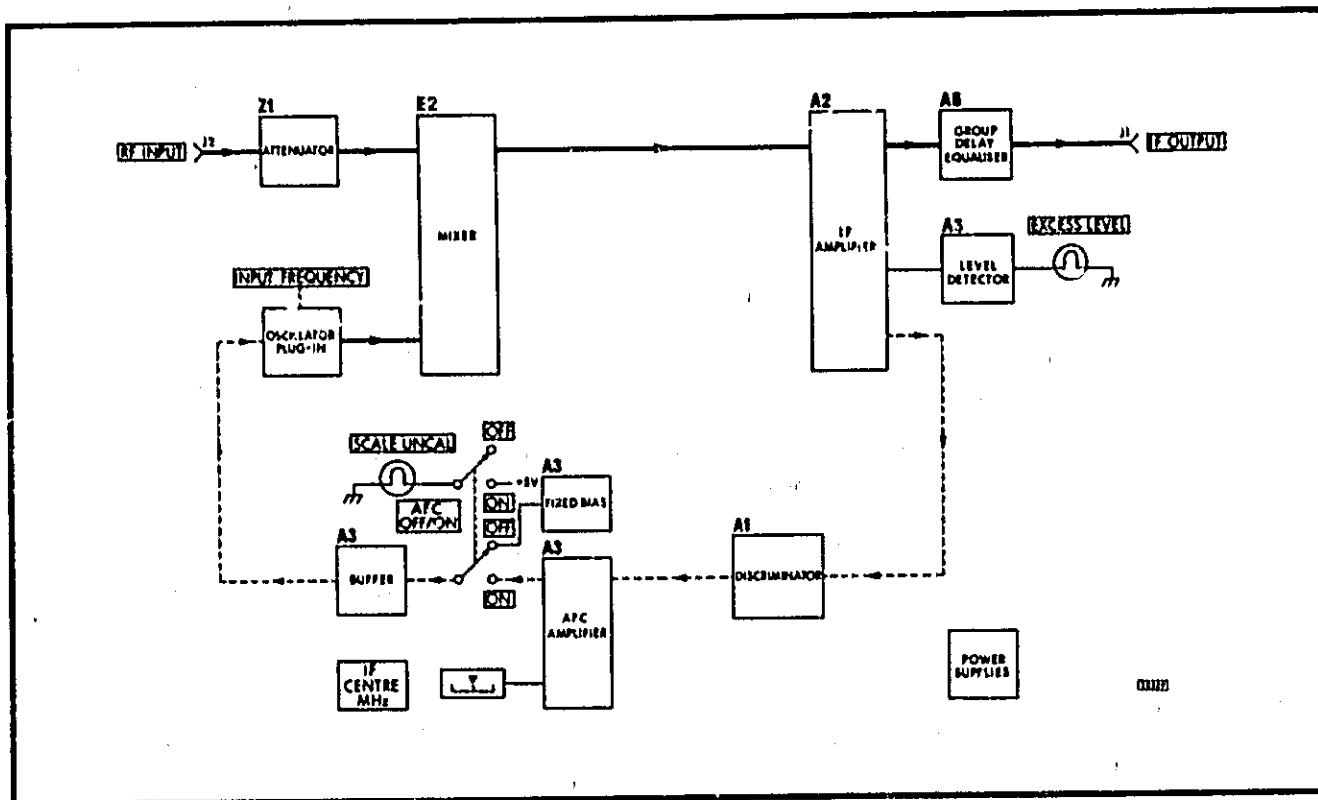

Figure G1-1 Simplified Block Diagram

G1-1 THEORY OF OPERATION

G1-2 The 3730A converts an RF signal input to an IF signal suitable for driving an *hp* Microwave Link Analyzer (MLA). The RF input signal can be in the range 1.7 to 11.7GHz, depending on the plug-in Oscillator selected, and have a typical input level of 0dBm. The IF output is at 70MHz and contains the frequency modulation and sweep components present on the RF input signal. An automatic frequency control (AFC) feature in the 3730A holds the IF output at 70MHz for RF carrier frequency drifts of up to ± 20 MHz. The AFC facility can be switched off to simplify setting up the Down Converter.

G1-3 The RF input signal to the Down Converter is fed via a 10dB attenuator and then mixed with the output from a plug-in Oscillator. The mixer output frequency is equal to the difference between the frequencies of the RF input and the

plug-in Oscillator output. The IF output signal from the mixer is amplified by an IF amplifier and then passed through a group delay equaliser to produce a signal capable of driving an *hp* MLA or other equipment.

G1-4 A second output from the IF amplifier is fed to a discriminator which supplies the loop amplifier with a dc signal proportional to the frequency of the IF. With the AFC switch ON, the output from the loop amplifier is fed via a buffer to the plug-in Oscillator to control the output frequency of the Oscillator such that the IF output from the Down Converter is maintained at 70MHz. The frequency response of the loop amplifier (>35 dB down at 18Hz) ensures that the AFC compensates for slow variations (eg, drift) in the input frequency but will not be affected by sweep frequencies. Thus, if the input is swept ± 25 MHz about the RF carrier, then the IF output will be swept ± 25 MHz about the 70MHz centre frequency.

G1-5 Note that when the AFC switch is ON, the SCALE UNCAL lamp is illuminated. This indicates that because the AFC is operative the RF input centre frequency may have drifted up to 20MHz from the original setting and the frequency indicated on the Oscillator RF input scale may be incorrect.

G1-6 With the AFC switch OFF, a fixed dc bias is applied to the Oscillator plug-in where it is summed with a control voltage to set the Oscillator frequency.

G1-7 A secondary output from the IF amplifier is used to monitor the IF signal amplitude and is applied to the input level detector. If the RF input level, and consequently the IF level, is too high the level detector operates the EXCESS LEVEL lamp, indicating that the RF input level should be reduced.

G1-8 TROUBLESHOOTING

G1-9 The troubleshooting is based on power level and voltage measurements made at various points in the instrument. The monitoring points are shown in the Functional Block Diagram, Figure G1-5. Information on each of these monitoring points is given in Table G1-1. The figures quoted in the table relate specifically to a 0dBm RF signal

input level.

G1-10 When using the troubleshooting information, it should be remembered that the power levels quoted can only be used as a guide to correct functioning of the 3730A. Also, the information is best used by starting at the RF INPUT and checking the individual power loss or gain of each section.

G1-11 If a fault is isolated to a particular assembly, the relevant assembly service sheet should be consulted. Each service sheet contains a schematic, circuit description, component location, and, where appropriate, an adjustment procedure. The schematics contain waveform and voltage information at test points and other appropriate locations, such as transistors, to assist in troubleshooting down to component level.

G1-12 Where there is no indication of wrong power levels or voltages, it may be helpful to carry out the adjustment procedure detailed in Section IV.

G1-13 Equipment Required

G1-14 Equipment required for troubleshooting is listed in the Recommended Test Equipment table in Section I of this manual. Any equipment that satisfies the critical specifications given in the table may be substituted for the recommended models.

Table G1-1 Test Point Information

Monitor Point	Location	Remarks	Typical Output (0dBm at RF INPUT)
1	Z1 O/P	10dB down relative to the input.	-10dBm
2	J4	Depends on Oscillator plug-in used.	Between +5 and +13dBm
3	E2J2	Mixer loss depends on the frequency and the mixer tolerance but should be between 6 and 9dB. Note that measurements on the power meter will include harmonic components and local oscillator breakthrough.	Between -16 and -10dBm
4	A2J4	IF amplifier gain should be 26 to 28dB.	Between +7 and +12dBm
5	A6J2	Group delay equaliser loss is typically 1dB.	Between +6 and +11dBm
6	A2J2	Increase input level to 3730A until EXCESS LEVEL lamp just lights.	0.4 ± 0.5V
7	A2J3	10 to 12dB down relative to A2J4.	Between -6 and +1dBm
8	A1J2	Measured at spot frequencies with no sweep. The voltages are typical. With sweep, the waveform should be a replica of the sweep waveform and proportional to the sweep range. E.g. a sinewave sweep of 40MHz width should produce a recovered sweep of 2.7V pk-pk.	6.9V at 90MHz 6.2V at 80MHz 5.6V at 70MHz 4.9V at 60MHz 4.2V at 50MHz
9	A3(H)	The voltage decreases as the frequency at the mixer output increases from 65 to 75MHz.	+0.6V at 65MHz -15V at 75MHz
10	A3(K)	AFC switch OFF	-3.7 ± 0.2V
11	A3(J)	AFC switch OFF	-4.4 ± 0.2V
12	A3(19), A3(20)	Voltage measured between A3(19) and A3(20).	+13.3V (approx).

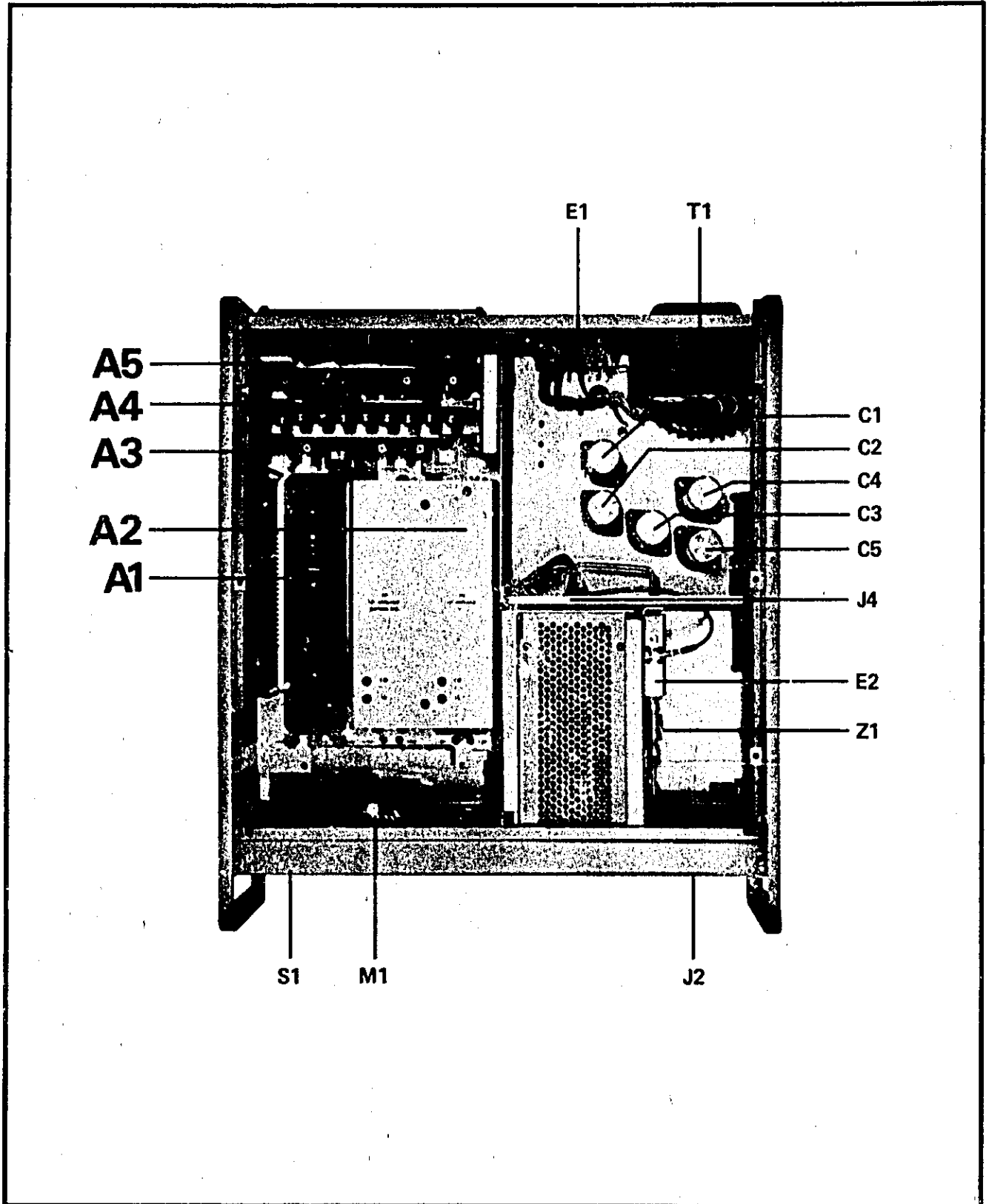

Figure G1-2 3730A Assembly Locations (Top View)

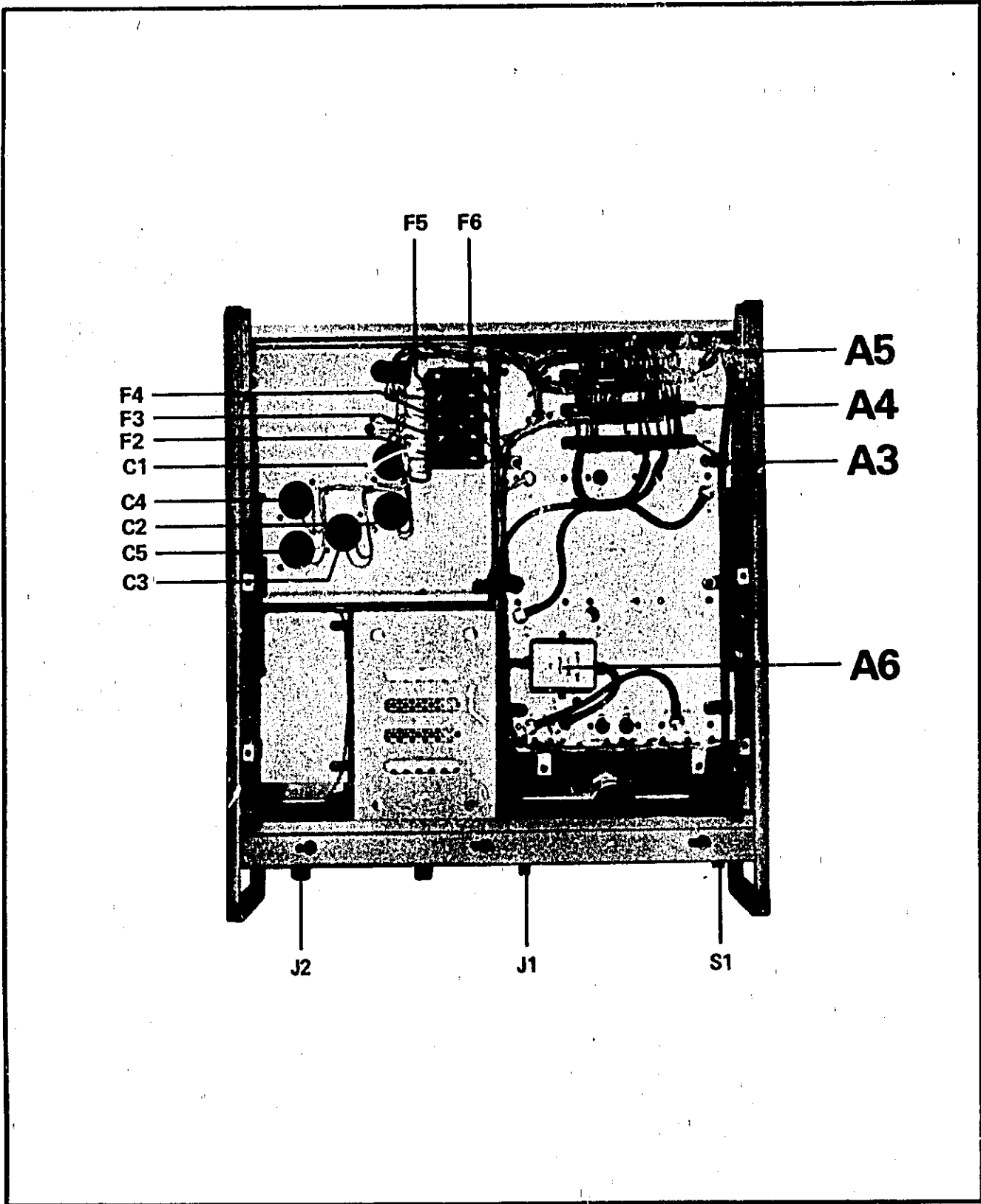

Figure G1-3 3730A Assembly Locations (Bottom View)

GENERAL SERVICE SHEET G2

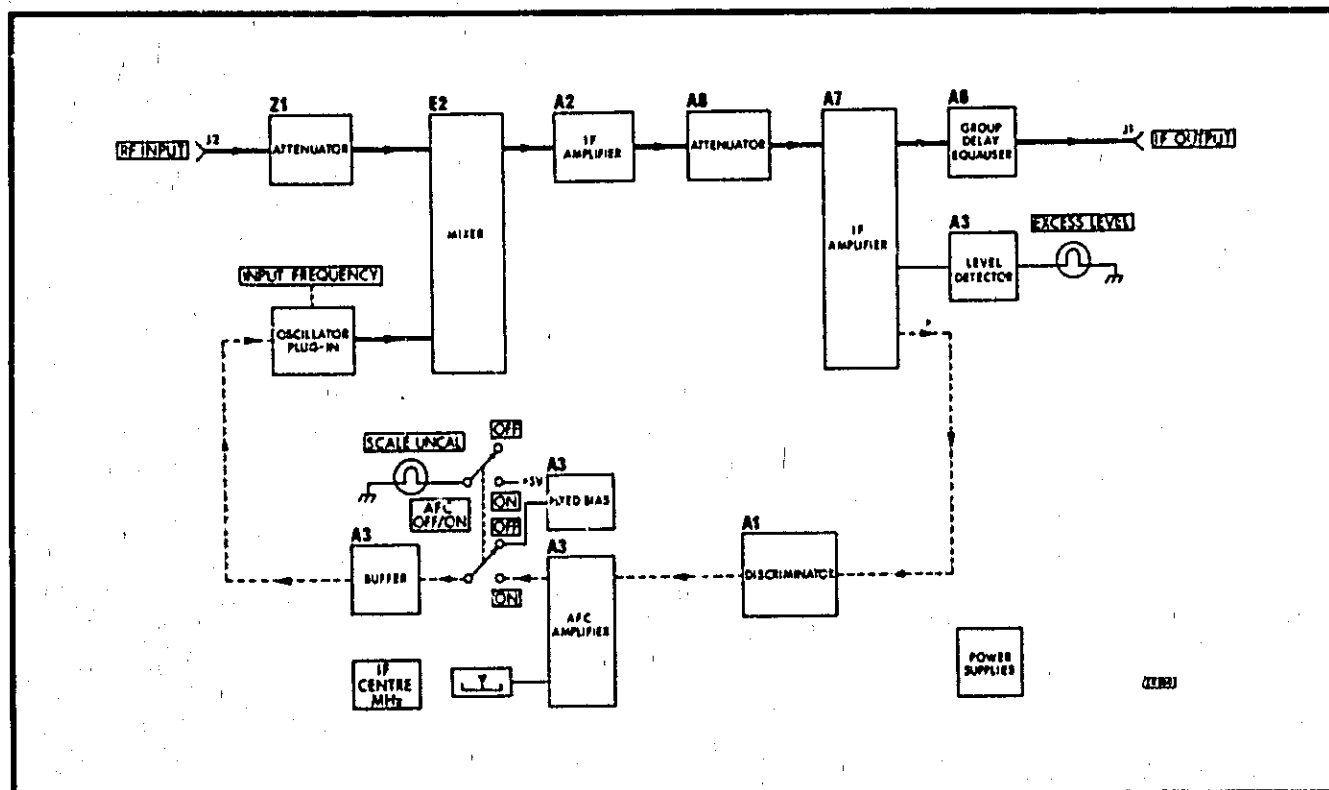

Figure G2-1 Simplified Block Diagram

G2-1 GENERAL

G2-2 This Service Sheet applies only to Option 010 versions of the 3730A.

G2-3 Option 010 adds to the basic Down Converter a 25dB amplifier (A7) and a five-section pushbutton attenuator (A8), adjustable in 1dB steps from 0 to 25dB.

G2-4 Note that Option 010 is a factory only conversion.

G2-5 THEORY OF OPERATION

G2-6 The theory of operation for the Option 010 Down Converter is very similar to that given in General Service Sheet G1. However, for convenience, the complete theory of operation is given here. The additional amplifier and attenuator between the

mixer output and IF amplifier input enable the minimum input level required to operate an *hp* Microwave Link Analyzer (MLA) to be reduced to -40dBm.

G2-7 The 3730A converts an RF signal input to an IF signal suitable for driving an *hp* MLA. The RF input signal can be in the range 1.7 to 11.7GHz, depending on the plug-in Oscillator selected, and have a typical input level of 0dBm. The IF output is at 70MHz and contains the frequency modulation and sweep components present on the RF input signal. An automatic frequency control (AFC) feature in the 3730A holds the IF output at 70MHz for RF carrier frequency drifts of up to ± 20 MHz. The AFC facility can be switched off to simplify setting up the Down Converter.

G2-8 The RF input signal to the Down Converter is fed via a 10dB attenuator and then mixed with the output from the plug-in Oscillator. The mixer

output frequency is equal to the difference between the frequencies of the RF input and the plug-in Oscillator output. The IF output signal from the mixer is fed via an IF amplifier and attenuator to a second IF amplifier. The output from the second IF amplifier is passed through a group delay equaliser to produce a signal capable of driving an *hp* MLA or other equipment.

G2-9 Another output from the second IF amplifier is fed to a discriminator which supplies the loop amplifier with a dc signal proportional to the frequency of the IF. With the AFC switch ON, the output from the loop amplifier is fed via a buffer to the plug-in Oscillator to control the output frequency of the Oscillator such that the IF output from the Down Converter is maintained at 70MHz. The frequency response of the loop amplifier ($>35\text{dB}$ down at 18Hz) ensures that the AFC compensates for slow variations (eg, drift) in the input frequency but will not be affected by sweep frequencies. Thus, if the input is swept $\pm 25\text{MHz}$ about the RF carrier, then the IF output will be swept $\pm 25\text{MHz}$ about the 70MHz centre frequency.

G2-10 Note that when the AFC switch is ON, the SCALE UNCAL lamp is illuminated. This indicates that because the AFC is operative, the RF input centre frequency may have drifted up to 20MHz from the original setting and the frequency indicated on the Oscillator RF input scale may be incorrect.

G2-11 With the AFC switch OFF, a fixed dc bias is applied to the plug-in Oscillator where it is summed with a control voltage to set the Oscillator frequency.

G2-12 A third output from the second IF amplifier is used to monitor the IF signal amplitude and is applied to the input level detector. If the RF input level, and consequently the IF level, is too

high the level detector operates the EXCESS LEVEL lamp indicating that the RF input level should be reduced.

G2-13 TROUBLESHOOTING

G2-14 The troubleshooting is based on power level and voltage measurements made at various points in the instrument. The monitoring points are shown in the Functional Block Diagram, Figure G2-5. Information on each of these monitoring points is given in Table G2-1. The figures quoted in the table relate specifically to a 0dBm RF signal input level.

G2-15 When using the troubleshooting information, it should be remembered that the power levels quoted can only be used as a guide to correct functioning of the 3730A. Also, the information is best used by starting at the RF INPUT and checking the individual power loss or gain of each section.

G2-16 If a fault is isolated to a particular assembly, the relevant assembly service sheet should be consulted. Each service sheet contains a schematic, circuit description, component location, and, where appropriate, an adjustment procedure. The schematics contain waveform and voltage information at test points and other appropriate locations, such as transistors, to assist in troubleshooting down to component level.

G2-17 Where there is no indication of wrong power levels or voltages, it may be helpful to carry out the adjustment procedure detailed in Section IV.

G2-18 Equipment Required

G2-19 Equipment required for troubleshooting is listed in the Recommended Test Equipment table in Section I of this manual. Any equipment that satisfies the critical specifications given in the table may be substituted for the recommended models.

Table G2-1 Test Point Information

Monitor Point	Location	Remarks	Typical Output (0dBm at RF INPUT)
1	Z1 O/P	10dB down relative to the input.	-10dBm
2	J4	Depends on Oscillator plug-in used.	Between +5 and +13dBm.
3	E2J2	Mixer loss depends on the frequency and the mixer tolerance but should be between 6 and 9dB. Note that measurements on the power meter will include harmonic components and local oscillator breakthrough.	Between -16 and -19dBm.
4	A2J4	IF amplifier gain should be 26 to 28dB.	Between +7 and +12dBm.
5	ABJ2	Attenuator insertion loss (ie, no attenuation inserted) should be less than 0.5dB. With 25dB inserted, total loss should not exceed 25.5dB, and typically will be 25.1dB.	Between -18.5 and -13.1dBm.
6	A7J4	IF amplifier gain should be 26 to 28dB.	Between +7.5 and +14.9dBm.
7	A6J2	Group delay equaliser loss is typically 1dB.	Between +6.5 and +13.9dBm.
8	A7J2	Increase input level to 3730A until EXCESS LEVEL lamp just lights.	0.4 ± 0.5V
9	A7J3	10 to 12dB down relative to A7J4.	Between -4.9 and 14.0dBm.
10	A1J2	Measured at spot frequencies with no sweep. The voltages are typical. With sweep, the waveform should be a replica of the sweep waveform and be proportional to the sweep range. E.g. a sinewave sweep of 40MHz width should produce a recovered sweep of 2.7V pk-pk.	6.9V at 80MHz 6.2V at 80MHz 5.6V at 70MHz 4.9V at 60MHz 4.2V at 50MHz
11	A3(H)	The voltage decreases as the frequency at the mixer output increases from 65 to 75MHz.	+0.6V at 65MHz -15V at 75MHz
12	A3(K)	AFC switch OFF	-3.7 ± 0.2V
13	A3(J)	AFC switch OFF	4.4 ± 0.2V
14	A3(19), A3(20)	Voltage measured between A3(19) and A3(20)	+13.3V (approx).

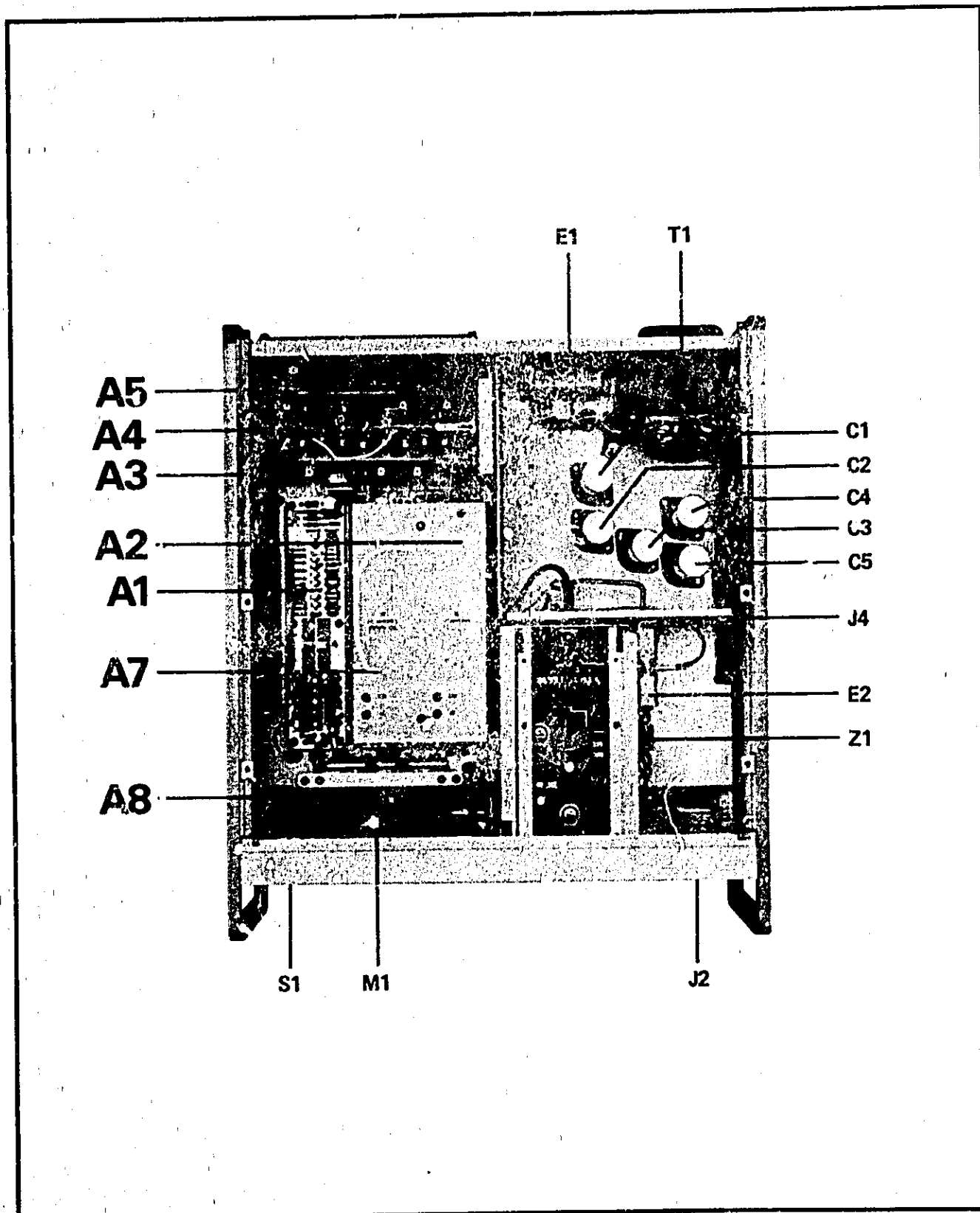

Figure G2-2 3730A Option 010 Assembly Locations (Top View)

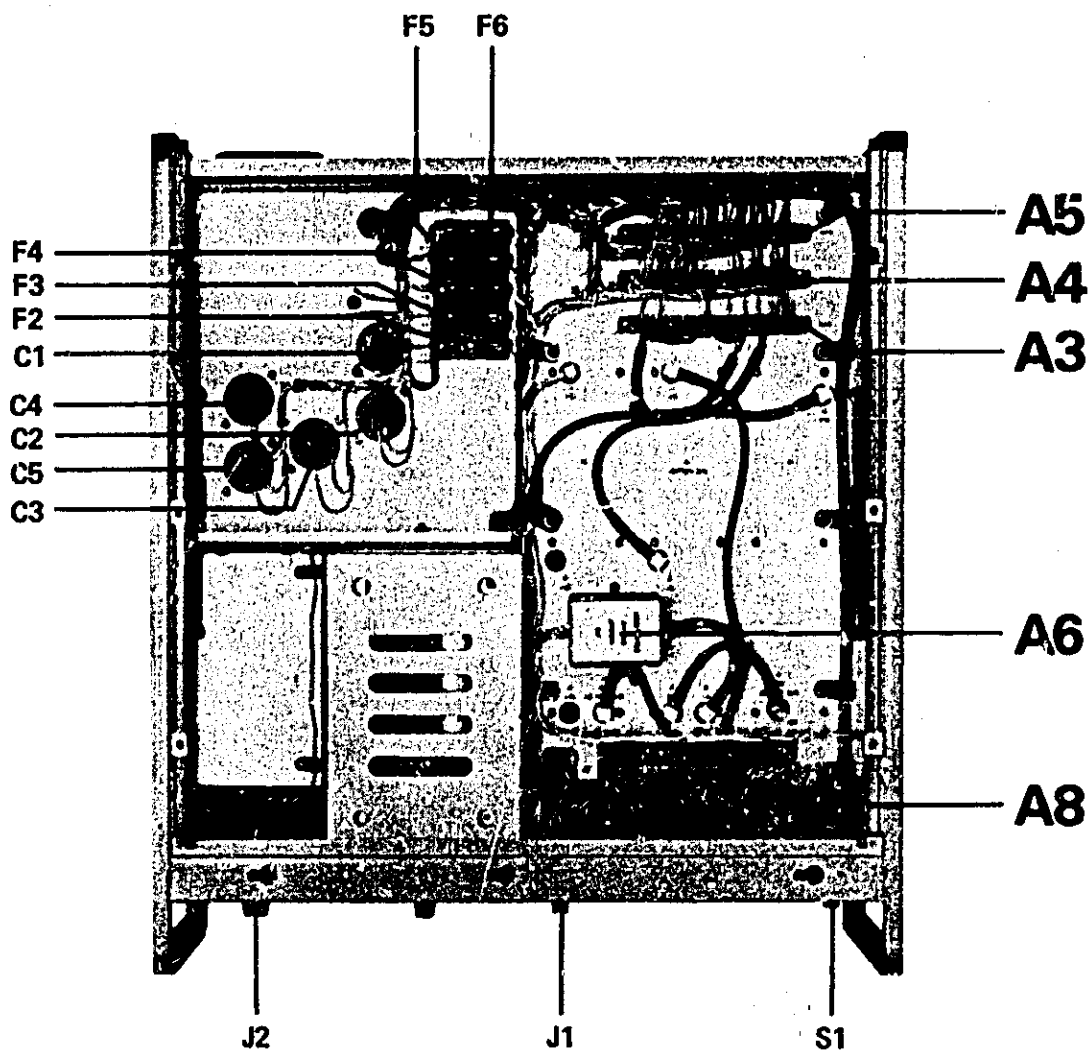

Figure G2-3 3730A Option 010 Assembly Locations (Bottom View)

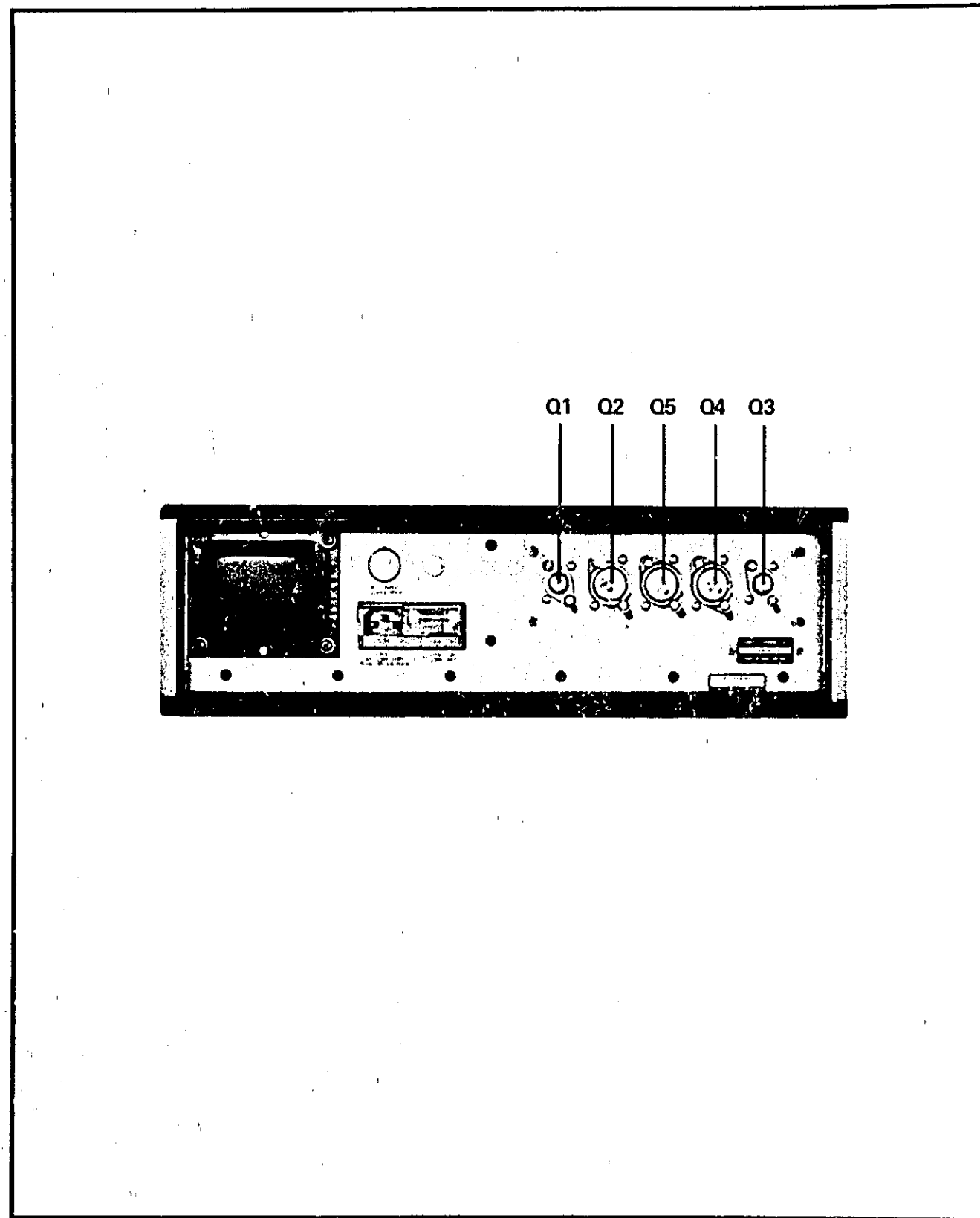

Figure G2-4 Rear Panel Transistors

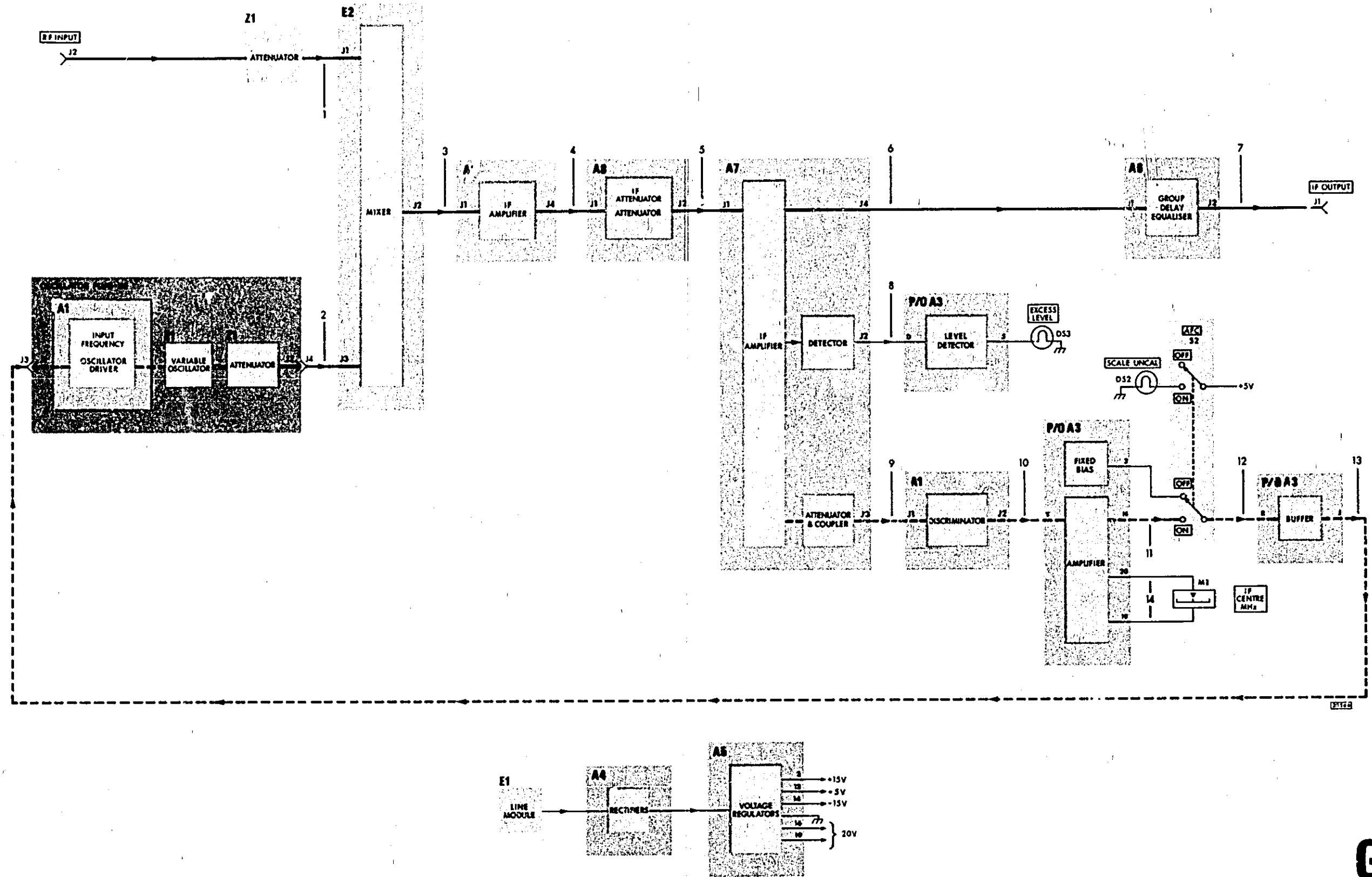

Figure G2-5 Functional Block Diagram

G2

ASSEMBLY SERVICE SHEET A1 – Discriminator

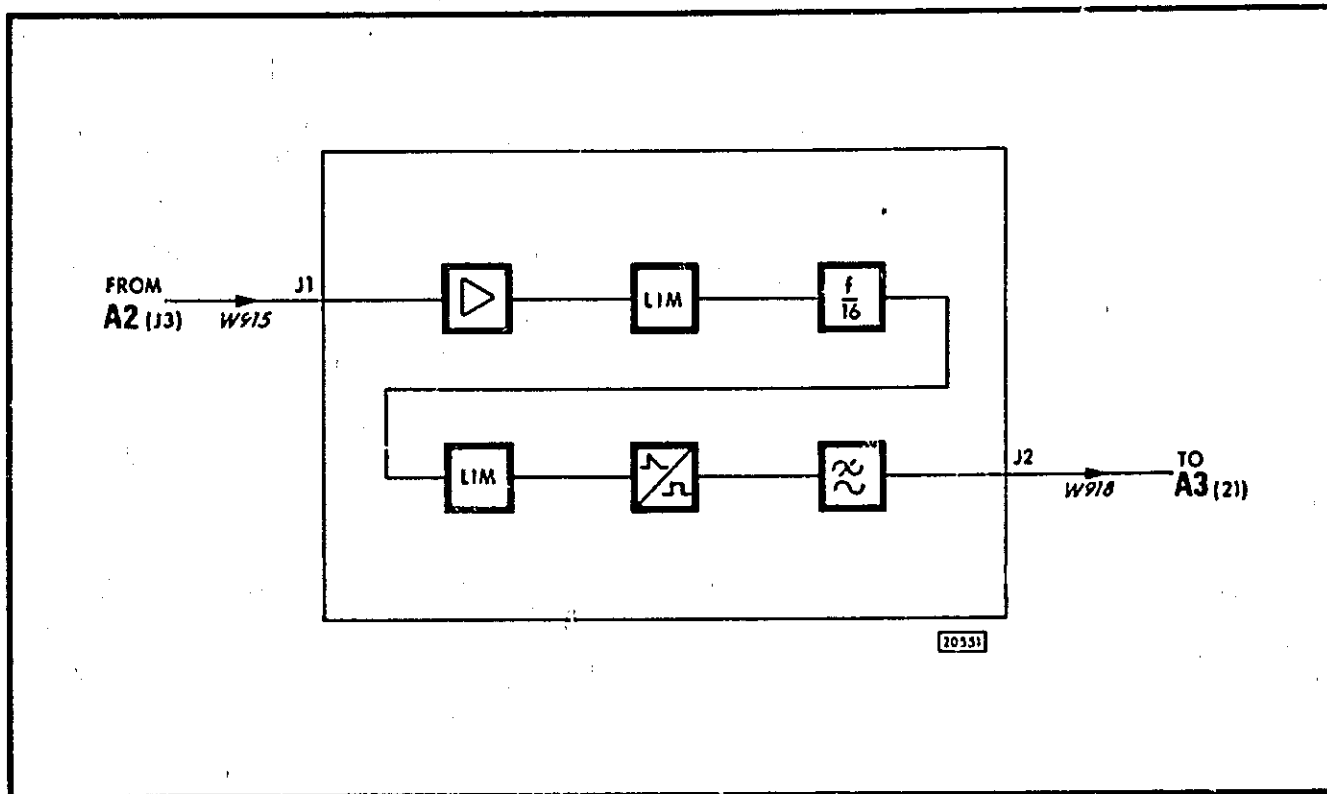

Figure A1-1 Simplified Block Diagram – Assembly A1

A1-1 CIRCUIT DESCRIPTION

A1-2 This assembly produces an AFC control signal for the A3 assembly. The IF input at J1 is fed to a wideband amplifier Q1 and Q2. Transistors Q3 and Q4 amplify and limit the IF signal to approximately 1V. Transistor Q5 acts as a buffer and provides the required drive for the divider circuitry. The signal is then divided by 16 in a ripple-through counter, comprising MC1 through MC4, to produce a more convenient pulse repetition frequency. The divider output, at an amplitude of 1V, is amplified and limited by Q6 and Q7 to produce a 5V pulse train suitable, after differentiation by C17 and R26, for triggering the monostable. The limiting action of Q6 and Q7 removes any residual IF remaining on the divider output. The monostable in conjunction with the low-pass filter provides a dc output proportional to the input frequency. When the input frequency is swept sinusoidally, the

monostable and filter provide a sinusoidally varying dc output.

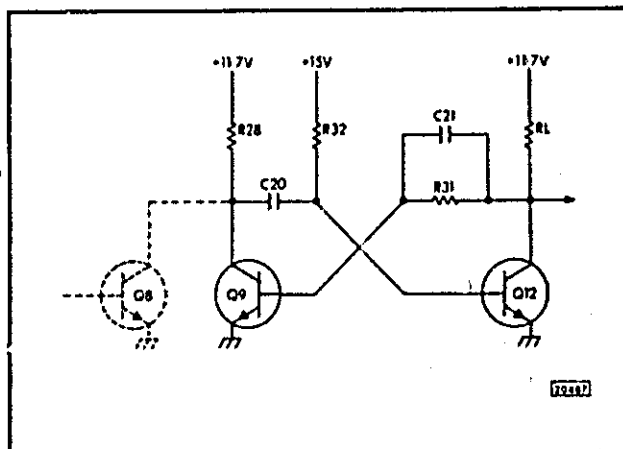

Figure A1-2 Simplified Monostable

A1-3 The circuit shown in Figure A1-2 is a simplified version of the monostable on the A1

Discriminator Assembly. The timing components C20 and R32 determine the pulse width and C21 is a speed-up capacitor to preserve the pulse shape.

A1-4 In the quiescent condition, ie, no signal, Q12 is saturated and Q9 cut off. When Q8 is switched on, the voltage at Q8 and Q9 collectors will fall towards 0V. Simultaneously this negative change in voltage will be applied to the base of Q12 (since the charge on C20 cannot be changed instantaneously) causing it to cut off. The voltage at Q12 collector will rise to 11.7V and Q9 will saturate. This condition will be maintained until C20 reaches the aiming potential and Q12 is turned on at approximately 0.7V, returning Q9 to the cut-off state.

A1-5 When the input pulse ends and Q8 is cut off, the positive change of voltage will not affect Q12 since it is already saturated. Should the input pulse end before C20 charges to the potential required to turn on Q12, the output will be unaffected

since Q9 is still saturated. The output pulse width is thus constant.

A1-6 When the input frequency changes, the output pulse width will remain the same but the period between the pulses will change, hence the average dc level will change (refer to Figure A1-3).

A1-7 The monostable on the Discriminator Assembly has the following additional components. Q10 and Q11 provide the fast current drive to C20 to restore the circuit to its quiescent state when Q9 and Q8 are returned to the cut off state. Hot carrier diode CR3 is added to prevent Q12 becoming heavily saturated and thus reduce the effect of carrier storage and to preserve the rising edge of the output pulse. CR1 prevents damage to the Q12 base-emitter junction and also alters the turn-on point of Q12 to approximately 1.2V. Q13 is a switched emitter follower and provides drive to the low-pass filter. Diodes CR2 and CR4 accurately reference the upper voltage level of the pulse.

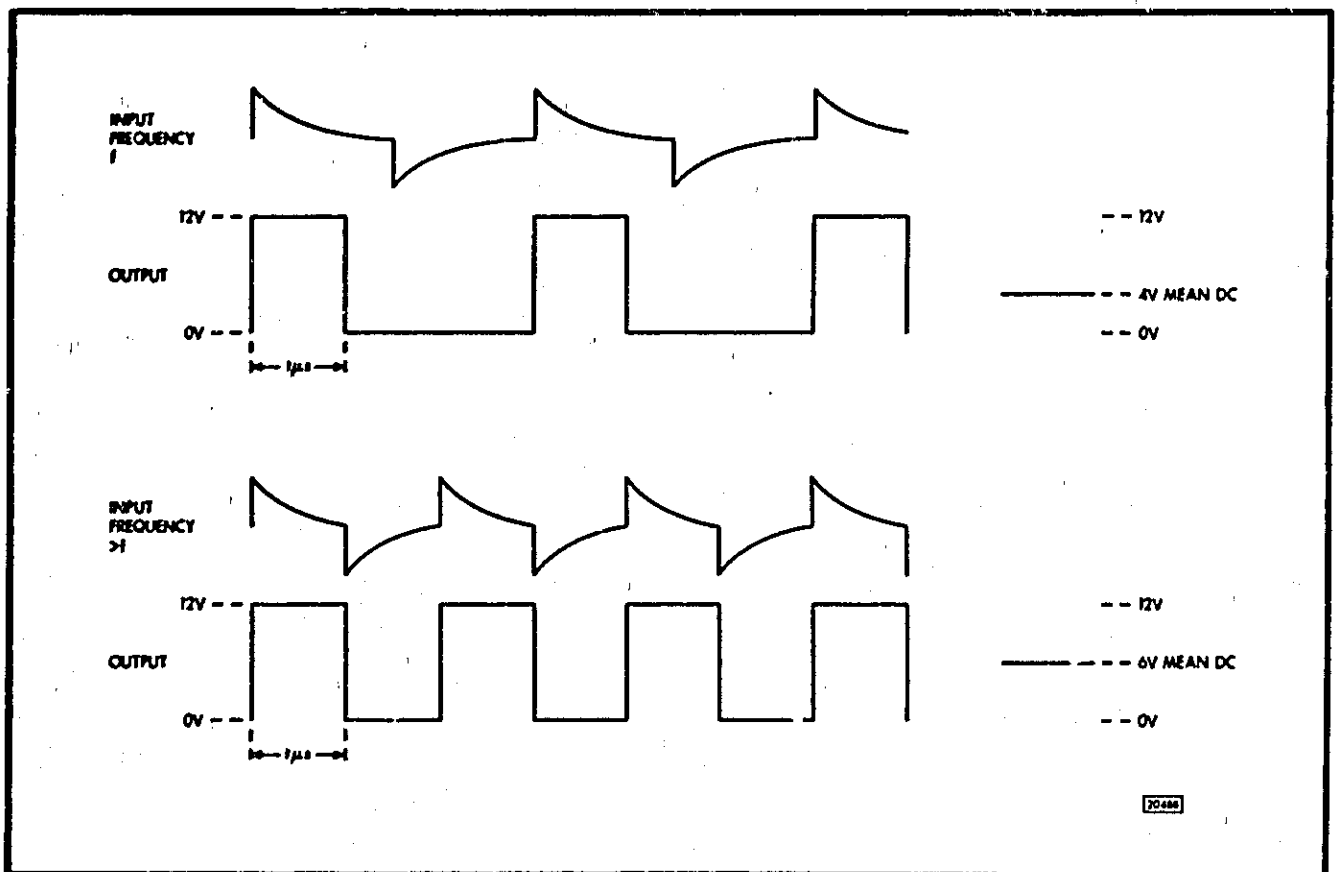

Figure A1-3 Monostable Waveforms

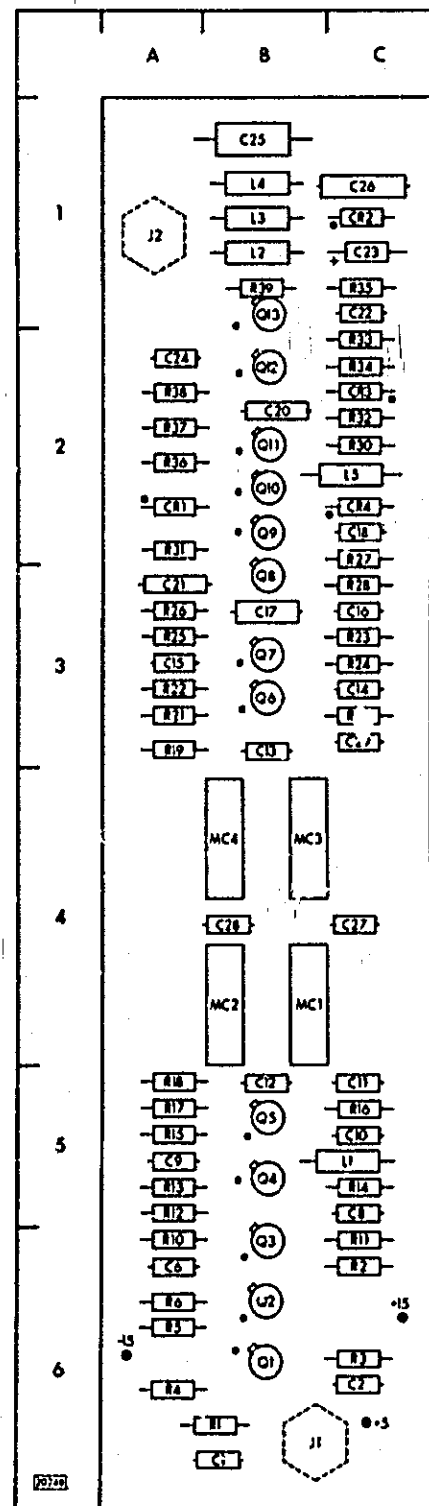

Figure A1-4 Component Location and Grid Reference - A1

C		L		R	
REF DESIG	GRID LOC	REF DESIG	GRID LOC	REF DESIG	GRID LOC
C1	B-6	L1	C-5	R1	A-6
C2	C-6	L2	B-1	R2	C-6
C6	A-6	L3	B-1	R3	C-6
C8	C-5	L4	B-1	R4	A-6
C9	A-5	L5	C-2	R5	A-6
C10	C-5			R6	A-6
C11	C-5			R10	A-6
C12	B-5			R11	C-6
C13	B-3			R12	A-5
C14	C-3			R13	A-5
C15	A-3			R14	C-5
C16	C-3			R15	A-5
C17	B-3			R16	C-5
C18	C-2			R17	A-5
C20	B-2			R18	A-5
C21	A-3			R19	A-3
C22	C-1			R20	C-3
C23	C-1			R21	A-3
C24	A-2			R22	A-3
C25	B-1			R24	C-3
C26	C-1			R25	A-3
C27	C-4			R26	A-3
C28	B-4			R27	C-2
C29	C-3			R28	C-3
				R30	C-2
				R31	A-2
				R32	C-2
				R33	C-2
				R34	C-2
				R35	C-1
				R36	A-2
				R37	A-2
				R38	A-2
				R39	B-1

MC		Q	
REF DESIG	GRID LOC	REF DESIG	GRID LOC
MC1	B-4	Q1	B-6
MC2	B-4	Q2	B-6
MC3	B-4	Q3	B-6
MC4	B-4	Q4	B-5
		Q5	B-5
		Q6	B-3
		Q7	B-3
		Q8	B-3
		Q9	B-2
		Q10	B-2
		Q11	B-2
		Q12	B-2
		Q13	B-1

CR		J	
REF DESIG	GRID LOC	REF DESIG	GRID LOC
CR1	A-2	J1	B-6
CR2	C-1	J2	A-1
CR3	C-2		
CR4	C-2		

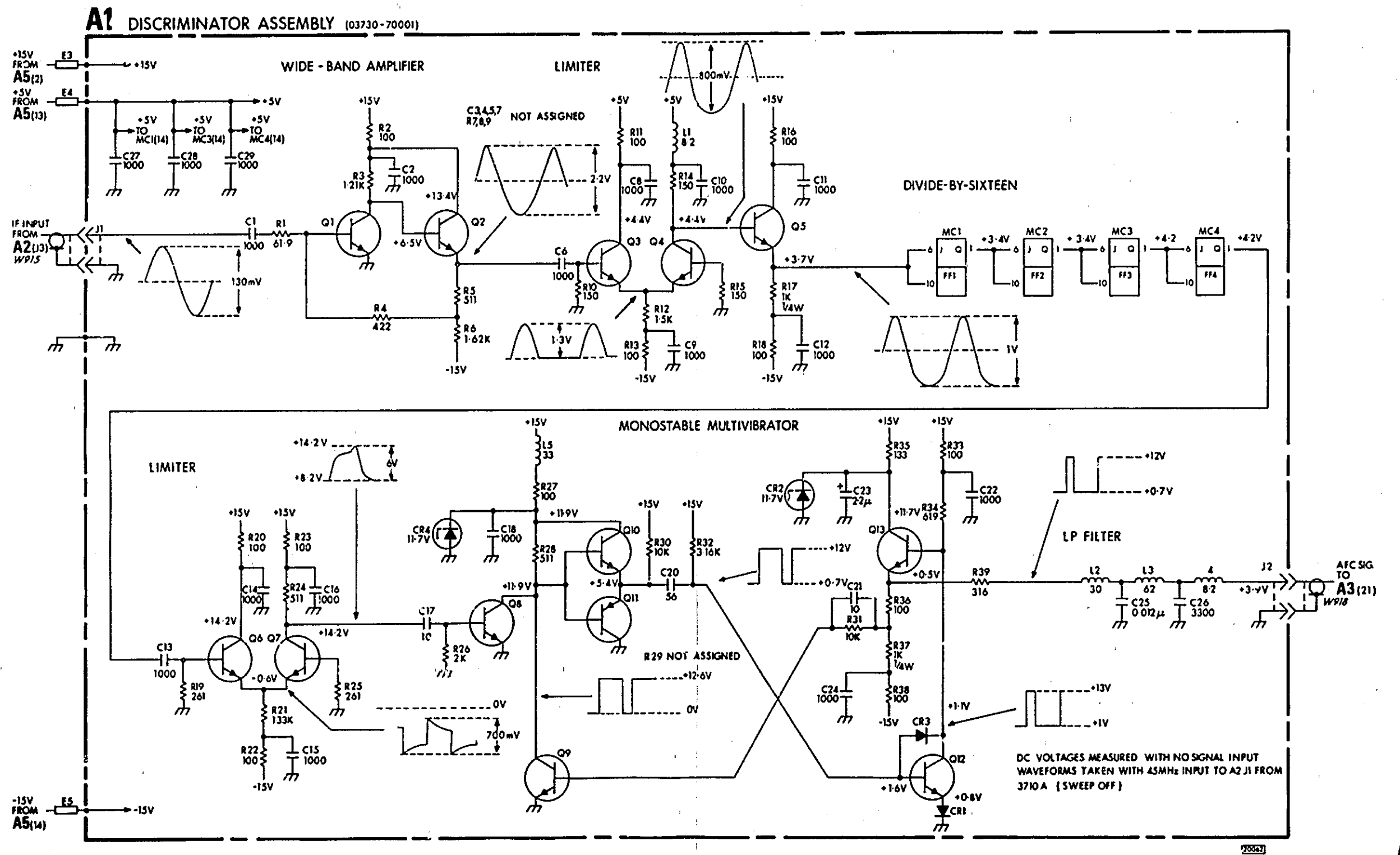

Figure A1-5 Schematic - Assembly A1

A1

ASSEMBLY SERVICE SHEET A2 – IF Amplifier

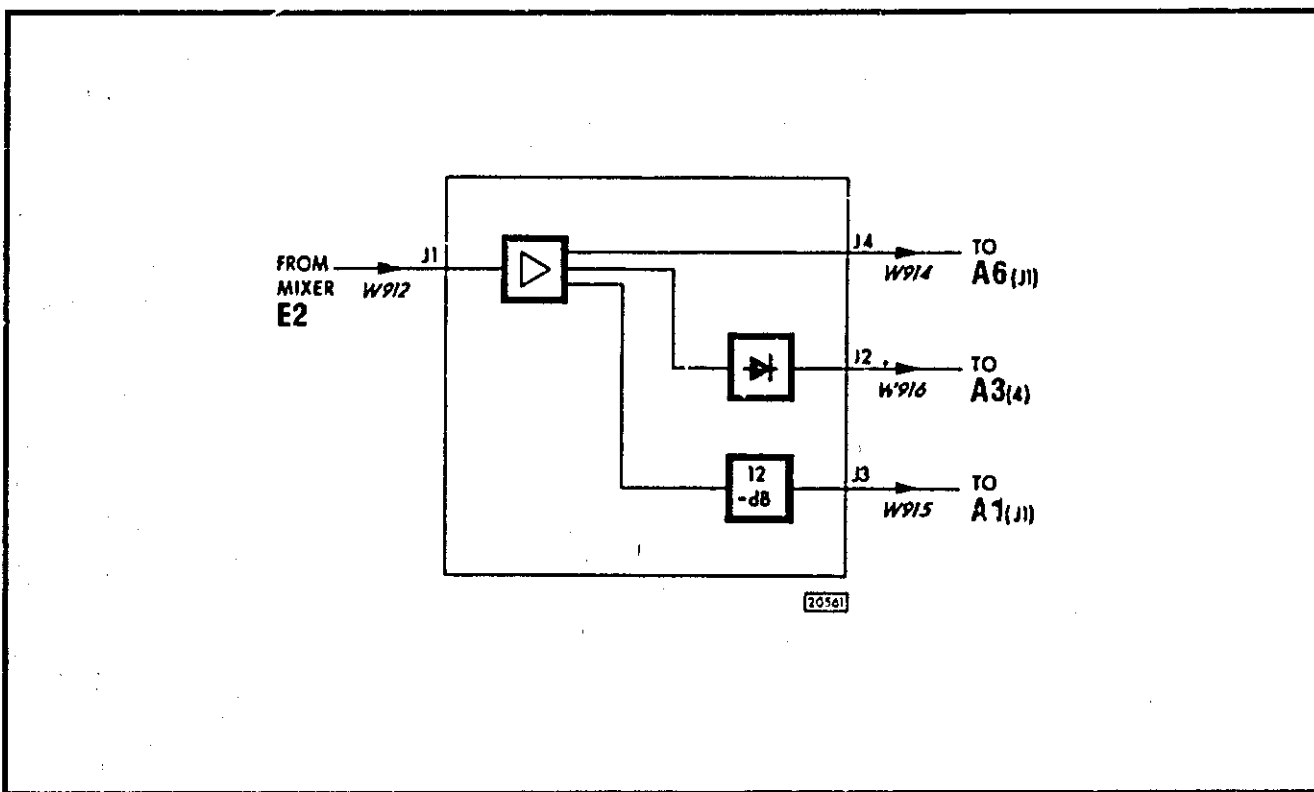

Figure A2-1 Simplified Block Diagram – Assembly A2

A2-1 CIRCUIT DESCRIPTION

A2-2 The IF output from the mixer is fed via the IF amplifier input socket J1 to a wideband amplifier. The seven stage amplifier has an overall gain of $26 \pm 1\text{dB}$, giving sufficient output to operate an *hp* MLA for a RF input signal in the range +5 to -17dBm.

A2-3 The amplifier, comprising grounded base transistors Q1 to Q7, has a flat frequency response. Amplitude flatness over the band 45 to 95MHz is adjusted by test select resistors R11 and R13, and by variable capacitor C38.

A2-4 The main IF output from Q7 collector is taken via the output socket J4, to the group delay equaliser. A second output from Q7 is fed through a 12dB coupler formed by T8 and associated components and then, via the output socket J3, to the discriminator for use in the AFC circuitry. The

coupler ensures that the main IF output is not loaded by the discriminator.

A2-5 A secondary output from the IF amplifier is derived from the collector of Q6 and is coupled by T7 to a high impedance detector Q8. The detector provides a voltage in proportion to the IF level at Q6 collector and is used to drive the level detector circuit on assembly A3.

A2-6 Resistors R22 to R41, and capacitors C16 to C37 are filter components for the +15V and -15V supplies.

A2-7 ADJUSTMENT PROCEDURE

A2-8 This procedure should be carried out after the board has been repaired or if the group delay or flatness are out of specification. Note that considerable changes in flatness will occur as the

temperature changes. Therefore, the final flatness should be checked after 20 minutes warm-up, and with the instrument as near as possible in the normal operating condition, ie, with all the covers fitted.

A2-9 Set up an MLA to measure simultaneously back-to-back IF amplitude response and group delay. With 10dB attenuation in both the MLA transmitter and MLA receiver IF attenuators, calibrate the IF amplitude response display for 0.1dB/cm and the group delay display for 1ns/cm. Record the displays (take a polaroid photograph or trace the waveform) for future reference.

A2-10 Connect the MLA transmitter IF output via a 75/50Ω matching pad to A2J1 on the 3730A. Connect A2J4 to the MLA receiver IF input. Insert extra attenuation in the MLA transmitter IF attenuator until an on-scale reading is obtained on the IF level meter on the MLA receiver. The A2 IF amplifier gain is the sum of the extra attenuation inserted and the power loss in the 75/50Ω matching pad. This should be 27dB.

A2-11 Adjust A2C38 for the best displayed flat-

ness. Compare the display with that of the back-to-back measurement to get the true response of the A2 IF amplifier. The IF amplitude response should be better than 0.15dB, and the group delay better than 1ns. A2R11 and A2R13 may be selected from values between 120 and 160Ω to achieve this flatness. Note that A2R13 is a special temperature coefficient resistor.

A2-12 Now connect A2J3 to the MLA receiver IF input and adjust the MLA transmitter IF attenuator until an on-scale reading is obtained on the MLA receiver. The difference between this setting on the IF attenuator and that of the back-to-back measurement plus the power loss in the 75/50Ω matching pad gives the gain at the auxiliary output A2J3. This should be 14 ±2dB.

A2-13 Measure the return loss at A2J4 using an MLA and a 75Ω hybrid. If necessary adjust A2L2 to achieve a return loss of better than 29dB.

A2-14 Measure the return loss at A2J1 using an MLA and a 50Ω hybrid. If necessary, adjust A2C1 to achieve a return loss of better than 23dB.

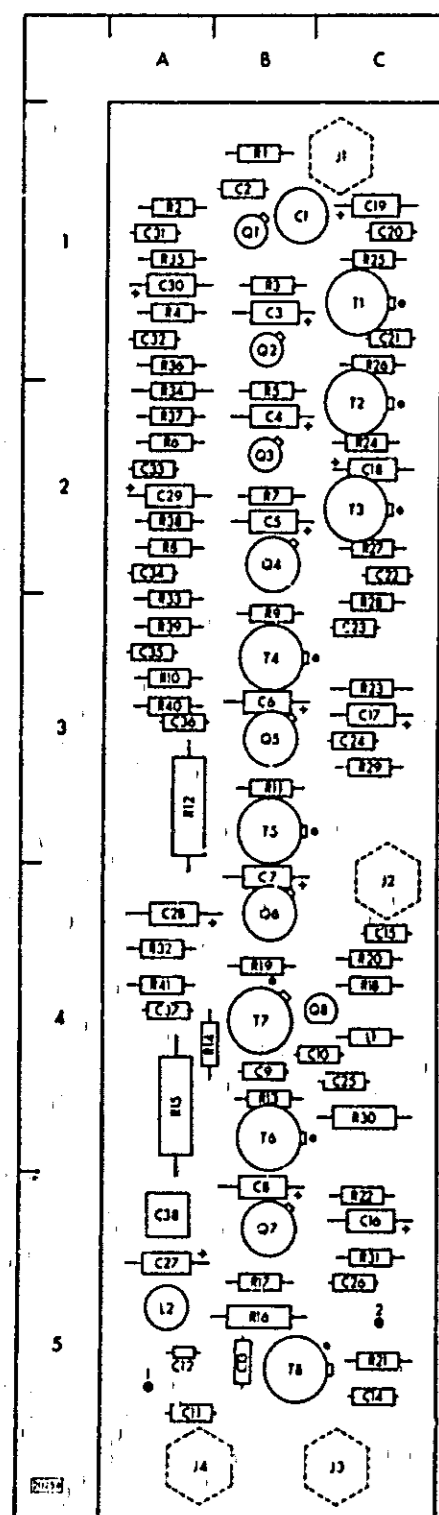

Figure A2-2 Component Location and Grid Reference - A2

REF DESIG	GRID LOC	REF DESIG	GRID LOC	REF DESIG	GRID LOC	REF DESIG	GRID LOC				
C1	B-1	J1	C-1	R10	A-3	C2	B-1	J2	C-4	R11	B-3
C3	B-1	J3	C-5	R12	A-3	C3	B-1	J3	C-5	R12	A-3
C4	B-2	J4	A-5	R13	B-4	C4	B-2	J4	A-5	R13	B-4
C5	B-2			R14	B-4	C5	B-2			R14	B-4
C6	B-3			R15	A-4	C6	B-3			R15	A-4
C7	B-4			R16	B-5	C7	B-4			R16	B-5
C8	B-5			R17	B-5	C8	B-5			R17	B-5
C9	B-4			R18	C-4	C9	B-4			R18	C-4
C10	B-4			R19	B-4	C10	B-4			R19	B-4
C11	A-5			R20	C-4	C11	A-5			R20	C-4
C12	A-5			R21	C-5	C12	A-5			R21	C-5
C13	B-5			R22	C-5	C13	B-5			R22	C-5
C14	C-5			R23	C-3	C14	C-5			R23	C-3
C15	C-4			R24	C-2	C15	C-4			R24	C-2
C16	C-5			R25	C-1	C16	C-5			R25	C-1
C17	C-3			R26	C-1	C17	C-3			R26	C-1
C18	C-2			R27	C-2	C18	C-2			R27	C-2
C19	C-1			R28	C-3	C19	C-1			R28	C-3
C20	C-1			R29	C-3	C20	C-1			R29	C-3
C21	C-1			R30	C-4	C21	C-1			R30	C-4
C22	C-2			R31	C-5	C22	C-2			R31	C-5
C23	C-3			R32	A-4	C23	C-3			R32	A-4
C24	C-3			R33	A-3	C24	C-3			R33	A-3
C25	C-4			R34	A-2	C25	C-4			R34	A-2
C26	C-5			R35	A-1	C26	C-5			R35	A-1
C27	A-5			R36	A-1	C27	A-5			R36	A-1
C28	A-4			R37	A-2	C28	A-4			R37	A-2
C29	A-2			R38	A-2	C29	A-2			R38	A-2
C30	A-1			R39	A-3	C30	A-1			R39	A-3
C31	A-1			R40	A-3	C31	A-1			R40	A-3
C32	A-2					C32	A-2				
C33	A-2					C33	A-2				
C34	A-2					C34	A-2				
C35	A-3					C35	A-3				
C36	A-3					C36	A-3				
C37	A-4					C37	A-4				
C38	A-5					C38	A-5				

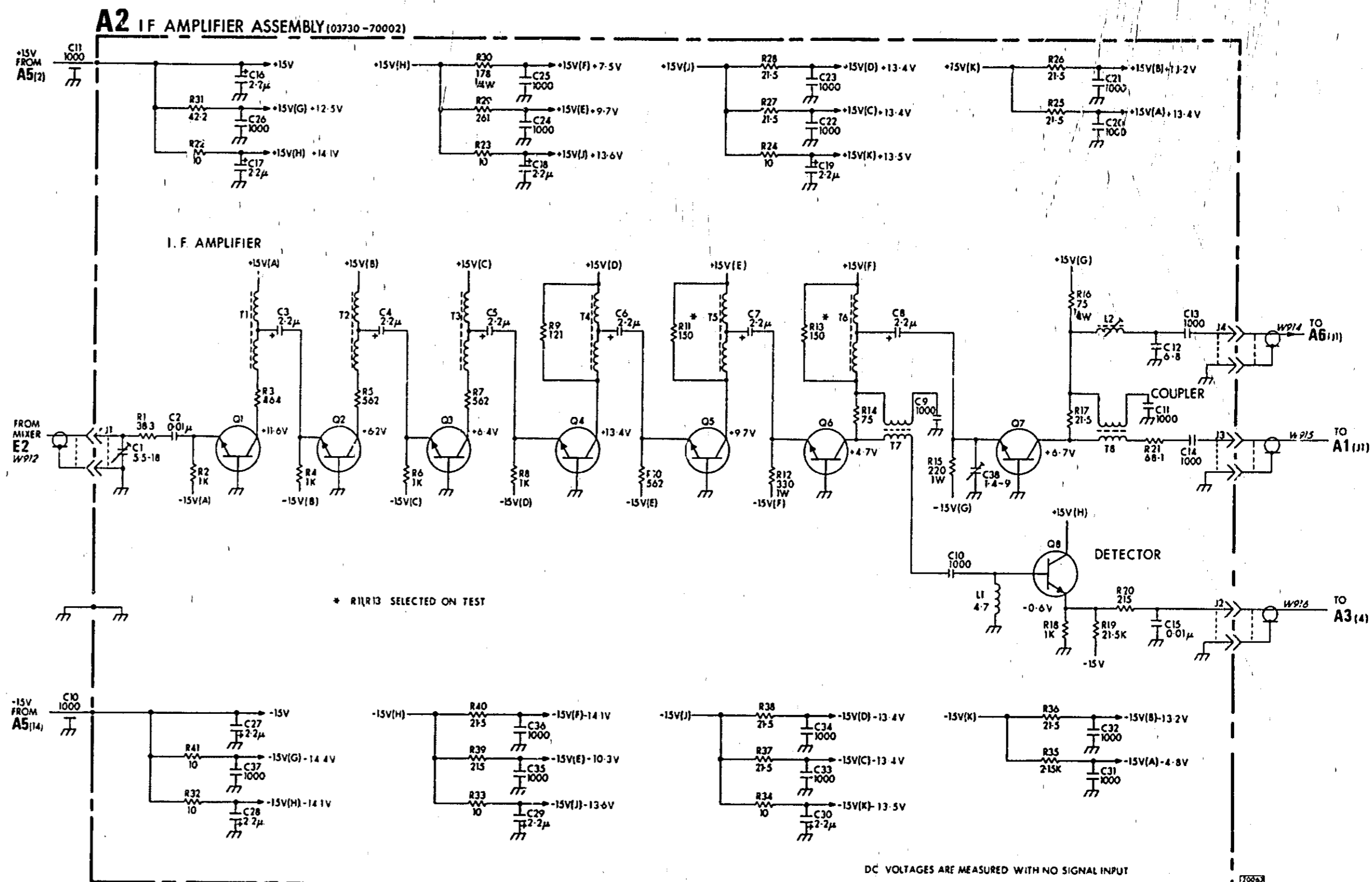

Figure A2-3 Schematic - Assembly A2

A2

ASSEMBLY SERVICE SHEET A3 – Loop Amplifier

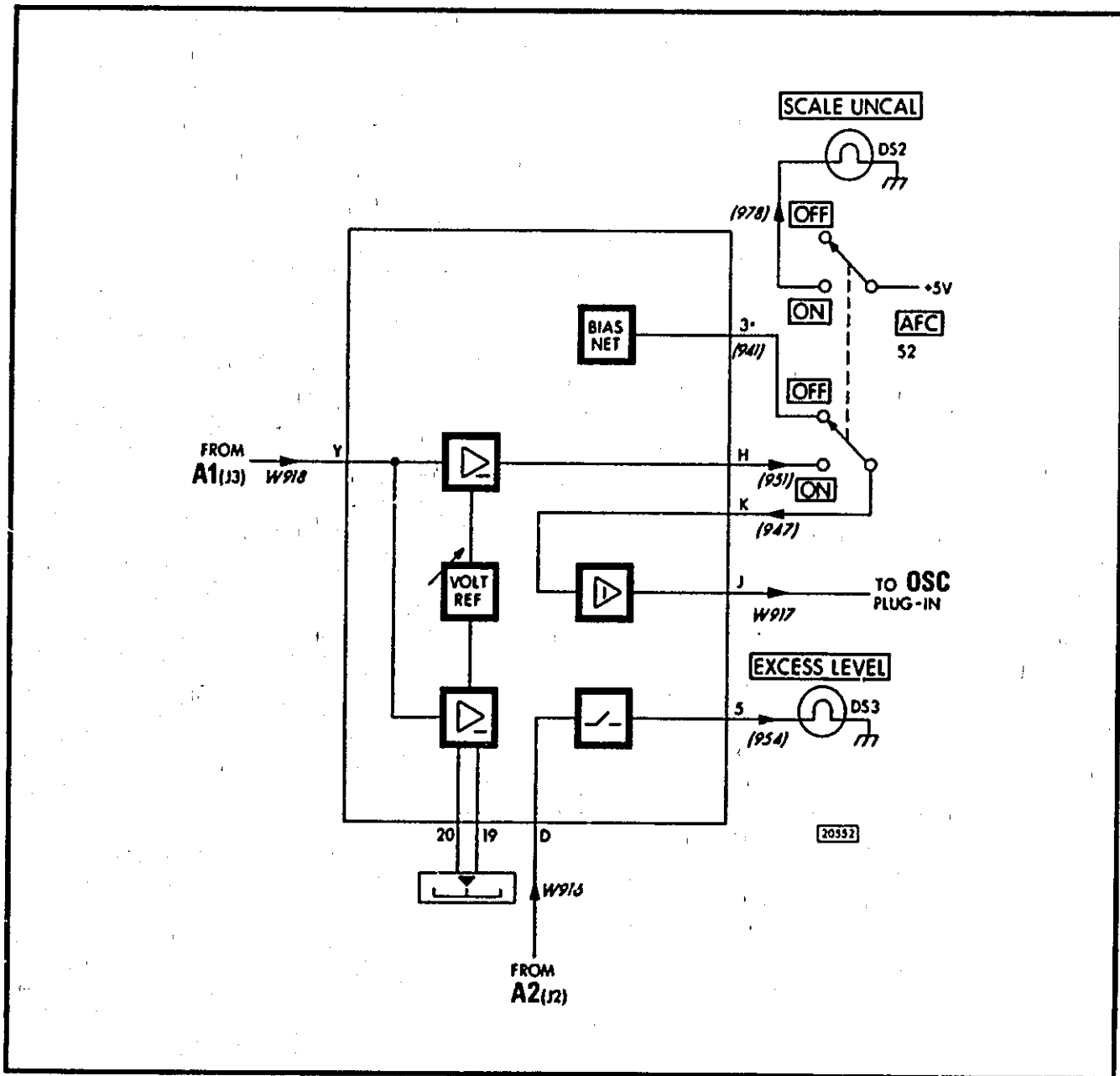

Figure A3-1 Simplified Block Diagram – Assembly A3

A3-1 CIRCUIT DESCRIPTION

A3-2 The dc output from the discriminator assembly is amplified by the loop amplifier and is used to control the frequency of the plug-in Oscillator. If the IF into the discriminator is swept then the discriminator output consists of the sweep fre-

quency superimposed on a fixed dc level. The frequency response of the amplifier (output level >35dB down on an input level at 18Hz) is such that sweep frequencies as low as 18Hz are rejected and only the dc component is amplified. Only if there is a change in the IF centre frequency into the discriminator, resulting in a change in the dc

component level, will there be any change in the amplifier output.

A3-3 The loop amplifier consists of three differential pairs Q1A and B, Q3A and B, and Q5 and Q6. Constant current generators Q2 and Q4 supply bias current to Q1A and B, and Q3A and B, respectively. The emitter voltages of Q2 and Q4 are fixed by CR1 and R8 and thus the current supplied to Q1A and B, and Q3A and B is determined by R4 and R14, respectively.

A3-4 A reference circuit supplies a dc bias, set by R32, to the base of Q1B equal to that obtained at J1 from the discriminator output when the IF output is at 70MHz.

A3-5 The loop amplifier is thus in balance at an IF of 70MHz and the resulting -4.5V dc output from Q7 fixes the frequency of the plug-in Oscillator at the centre of its tuning range. Any variation in the IF from 70MHz results in a change in output from Q7 and, therefore, a corresponding change in the plug-in Oscillator frequency to bring the IF back to 70MHz. With the AFC switch S2 in the

OFF position, the loop amplifier is disconnected and the plug-in Oscillator AFC input is biased by R20 and R21. The Oscillator frequency can then be manually adjusted to give an IF output in the range 45 to 95MHz.

A3-6 The amplifier Q8A and B drives the IF CENTRE meter M1. At 70MHz the voltages on Q8A base (discriminator output) and Q8B base (reference voltage) are equal and the amplifier is balanced, resulting in no current through the centre zero meter. At other IF frequencies the amplifier is unbalanced, giving a meter deflection. Capacitor C6 provides meter damping to prevent needle tremour due to sweep frequencies. Meter sensitivity can be adjusted by R26.

A3-7 The signal from A2Q8 is applied to the level detector Q10 to Q13. When the IF OUTPUT level is greater than +12dBm the signal on Q10A base will be greater than the voltage set on Q10B base by R42. Transistor Q10A will conduct, driving the very high gain stage Q11, Q12 and Q13 into saturation, ie, hard on, illuminating the EXCESS LEVEL lamp DS3.

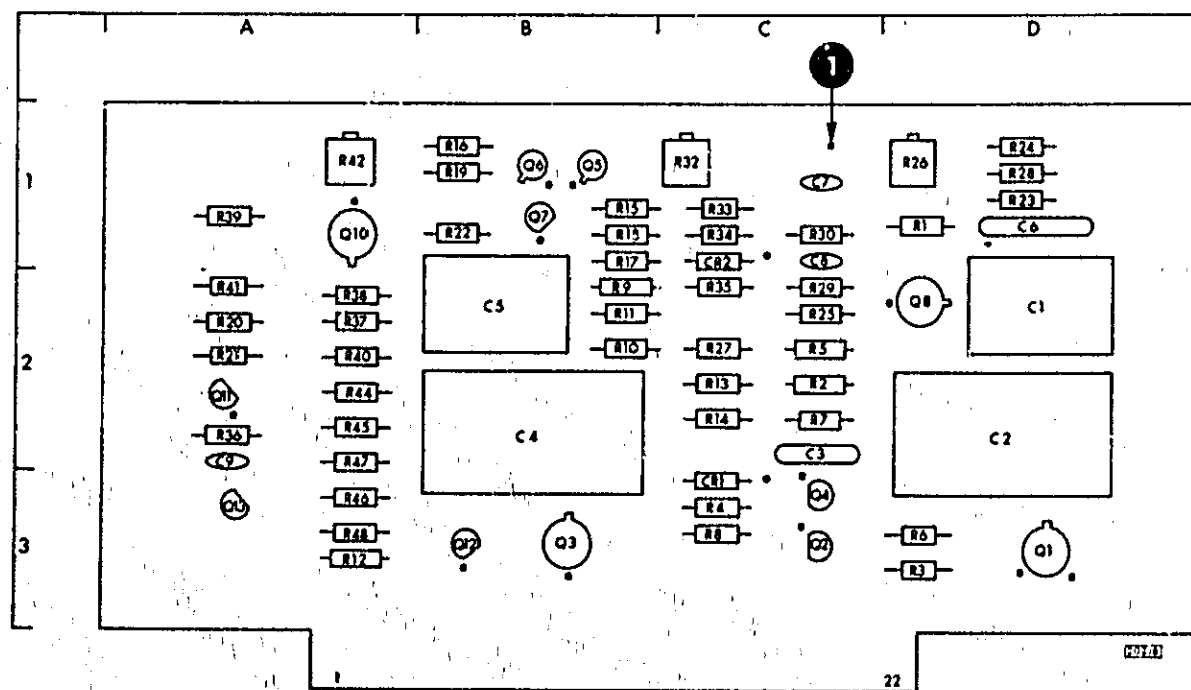

C		Q		R		C		Q		R	
REF DESIG	GRID LOC	REF DESIG	GRID LOC	REF DESIG	GRID LOC	REF DESIG	GRID LOC	REF DESIG	GRID LOC	REF DESIG	GRID LOC
C1	D-2	Q1	D-3	R4	C-3	R31	C-1	C1	D-2	Q1	D-3
C2	D-2	Q2	C-3	R5	C-2	R32	C-1	C2	D-2	Q2	C-3
C3	C-2	Q3	B-3	R6	D-3	R33	C-1	C3	C-2	Q3	B-3
C4	F-2	Q4	C-3	R7	C-2	R34	C-1	C4	F-2	Q4	C-3
C5	B-2	Q5	B-1	R8	C-3	R35	C-2	C5	B-2	Q5	B-1
C6	D-1	Q6	B-1	R9	B-2	R36	A-2	C6	D-1	Q6	B-1
C7	C-1	Q7	B-1	R10	B-2	R37	A-2	C7	C-1	Q7	B-1
C8	C-1	Q8	D-2	R11	B-2	R38	A-2	C8	C-1	Q8	D-2
C9	A-2	Q9	C-1	R12	A-3	R39	A-1	C9	A-2	Q9	C-1
		Q10	A-1	R13	C-2	R40	A-2			Q10	A-1
		Q11	A-2	R14	C-2	R41	A-2			Q11	A-2
		Q12	B-3	R15	B-1	R42	A-1			Q12	B-3
		Q13	A-3	R16	B-1	R43	A-2			Q13	A-3
				R17	B-1	R44	A-2				
				R18	B-1	R45	A-2				
				R19	B-1	R46	A-3				
				R20	A-2	R47	A-2				
				R21	A-2	R48	A-3				
				R22	B-1						
				R23	D-1						
				R24	D-1						
				R25	C-2						
				R26	D-1						
				R27	C-2						
				R28	D-1						
				R29	C-2						
				R30	C-1						

Figure A3-2 Component Location and Grid Reference - A3

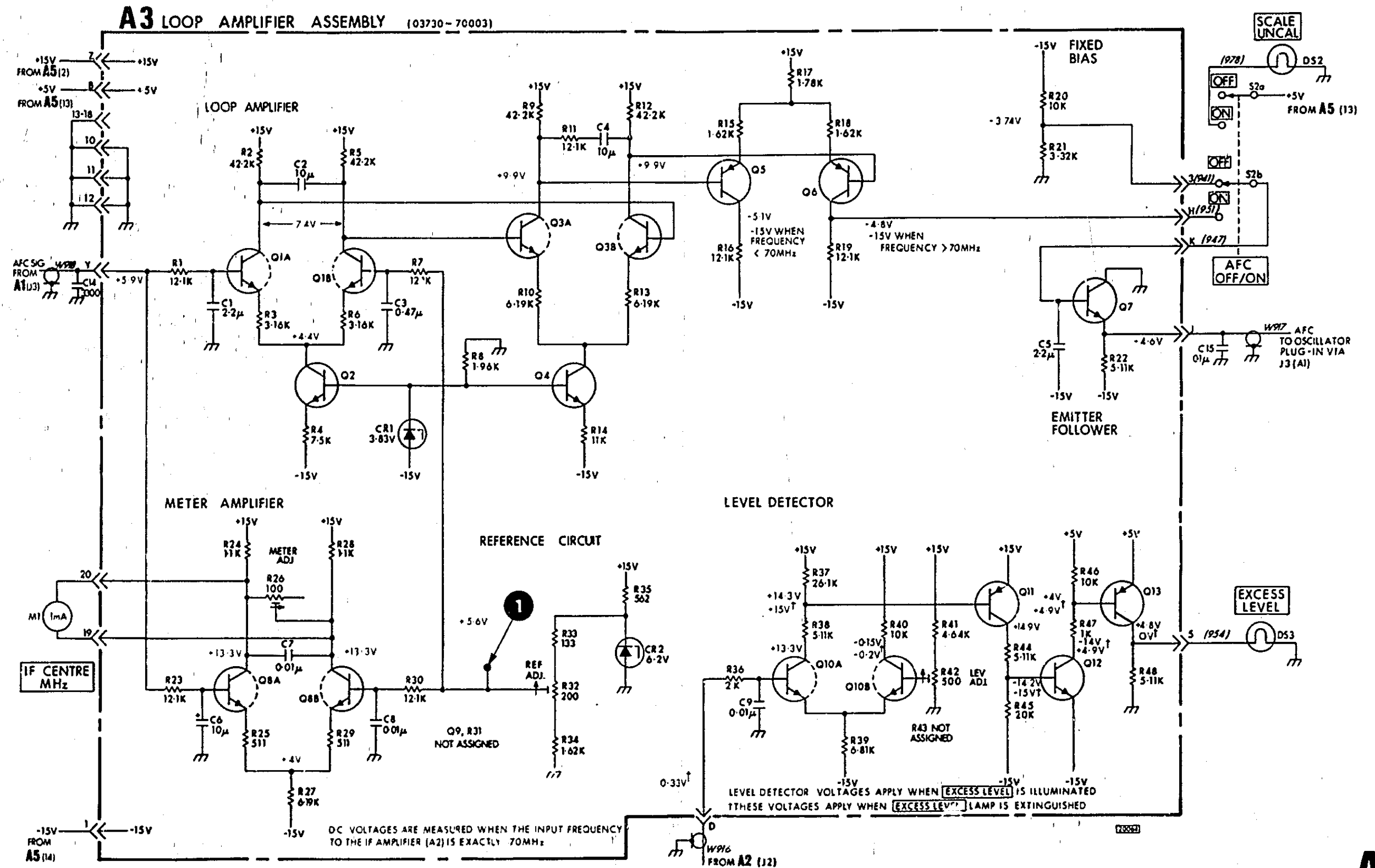

Figure A3-3 Schematic - Assembly A3

A3

ASSEMBLY SERVICE SHEET A4/A5 -- Rectifier and Regulator

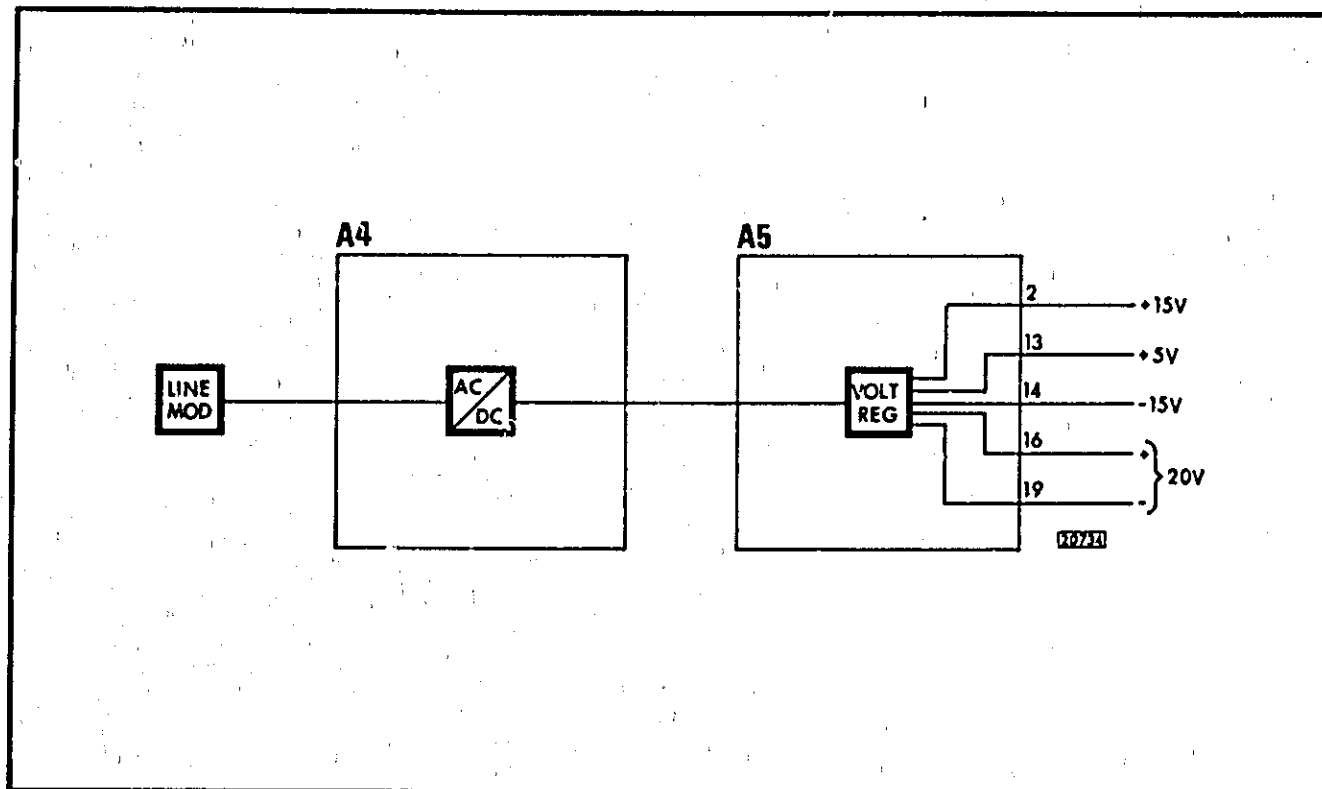

Figure A4-1 Simplified Block Diagram — Assemblies A4/A5

A4-1 CIRCUIT DESCRIPTION

A4-2 Power supplies for the operation of the Down Converter, and the plug-in Oscillator, are derived from the local ac supply. A 230V/115V voltage selector and line fuse are included in the line module E1 beside the input connector.

A4-3 Consider each supply separately.

A4-4 +100V supply

A4-5 A reference voltage from breakdown diode A5CR1 is applied to the base of the series regulator Q1. The +100V supply is thus regulated by Q1 sensing voltage changes between its base and emitter and adjusting the current available from the half wave rectifier A4CR1.

A4-6 +15V Supply

A4-7 The differential amplifier A5Q3 compares a

voltage proportional to the +15V output, set by A5R12 (+15V adjust), with the reference voltage of breakdown diode A5CR2. Any voltage change sensed is amplified by A5Q2 and A5Q1 to control the current made available by the +15V series regulator, Q2, from the full wave bridge rectifier A4CR2 – A4CR5. Note that the circuit operation is dependent on the +100V supply.

A4-8 +5V Supply

A4-9 A reference voltage from breakdown diode A5CR3 is applied to the base of the +5V series regulator Q3. The +5V supply is thus regulated by Q3 sensing voltage changes between its base and emitter, and adjusting the current available from the full wave bridge rectifier A4CR6 – A4CR9.

A4-10 -15V Supply

A4-11 The differential amplifier A5Q6 compares

a voltage proportional to the -15V output, set by A5R21 (-15V adjust) with the reference voltage of breakdown diode A5CR4. Any voltage change sensed is amplified by A5Q5 and A5Q4 to control the current made available by the -15V series regulator, Q4, from the full wave bridge rectifier A4CR10 – A4CR13. Note that the circuit operation is dependent on the +100V supply.

A4-12 20V Floating Supply

A4-13 The differential amplifier A5Q9 compares a voltage proportional to the 20V output, set by A5R30 (20V adjust), with the reference voltage of breakdown diode A5CR5. Any voltage change sensed is amplified by A5Q8 and A5Q7 to control the current made available by the 20V series regulator, Q5, from the full wave bridge rectifier A4CR14 – A4CR17. Note that the circuit operation is dependent on the +100V supply.

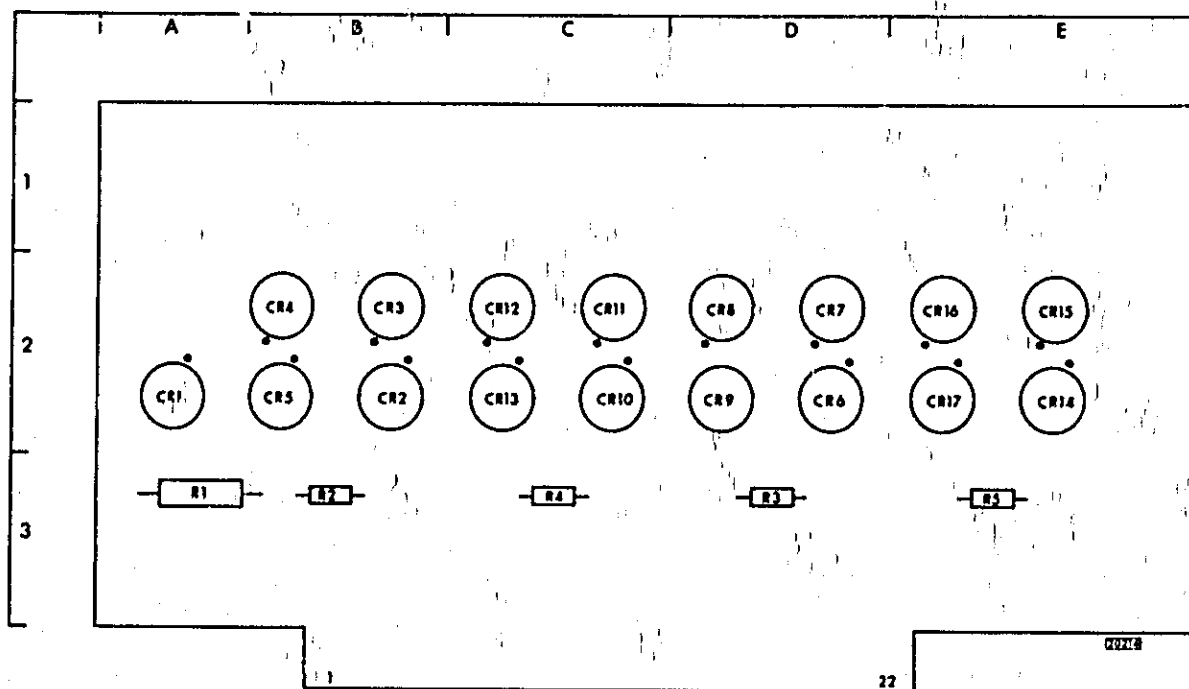

CR		CR18	E-2
REF	GRID	CR17	E-2
DESIG	LOC	R	
		REF	GRID
		DESIG	LOC
CR1	A-2	R1	A-3
CR2	B-2	R2	B-3
CR3	B-2	R3	D-3
CR4	B-2	R4	C-3
CR5	B-2	R5	E-3
CR6	D-2		
CR7	D-2		
CR8	D-2		
CR9	D-2		
CR10	C-2		
CR11	C-2		
CR12	C-2		
CR13	C-2		
CR14	E-2		
CR15	E-2		

Figure A4-2 Component Location and Grid Reference — A4

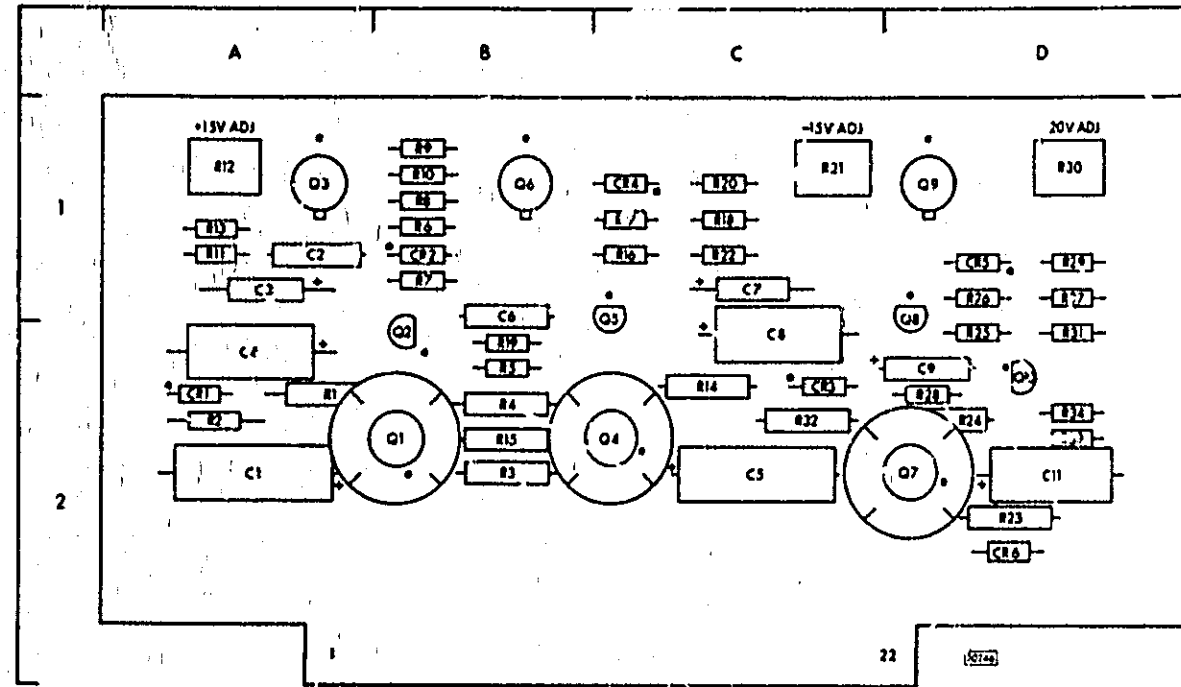

C		Q		R	
REF DESIG	GRID LCC	REF DESIG	GRID LOC	REF DESIG	GRID LOC
C1	A-2	Q1	B-2	R7	B-1
C2	A-1	Q2	B-2	R8	B-1
C3	A-1	Q3	A-1	R9	B-1
C4	A-2	Q4	C-2	R10	B-1
C5	C-2	Q5	C-1	R11	A-1
C6	B-1	Q6	B-1	R12	A-1
C7	C-1	Q7	D-2	R13	A-1
C8	C-2	Q8	D-1	R14	C-1
C9	D-2	Q9	D-1	R15	B-2
C10	D-2	Q10	D-2	R16	C-1
C11	D-2			R17	C-1
CR		R		R18	C-1
REF DESIG	GRID LOC	REF DESIG	GRID LOC	R19	B-2
CR1	A-2	R1	A-2	R20	C-1
CR2	B-1	R2	A-2	R21	C-1
CR3	C-2	R3	B-2	R22	C-1
CR4	C-1	R4	B-2	R23	D-2
CR5	D-1	R5	B-2	R24	D-2
		R6	B-1	R25	D-2
				R26	D-1
				R27	D-1
				R28	D-2
				R29	D-1
				R30	D-1
				R31	D-2
				R32	C-2
				R33	D-2
				R34	D-2

Figure A4-3 Component Location and Grid Reference - A5

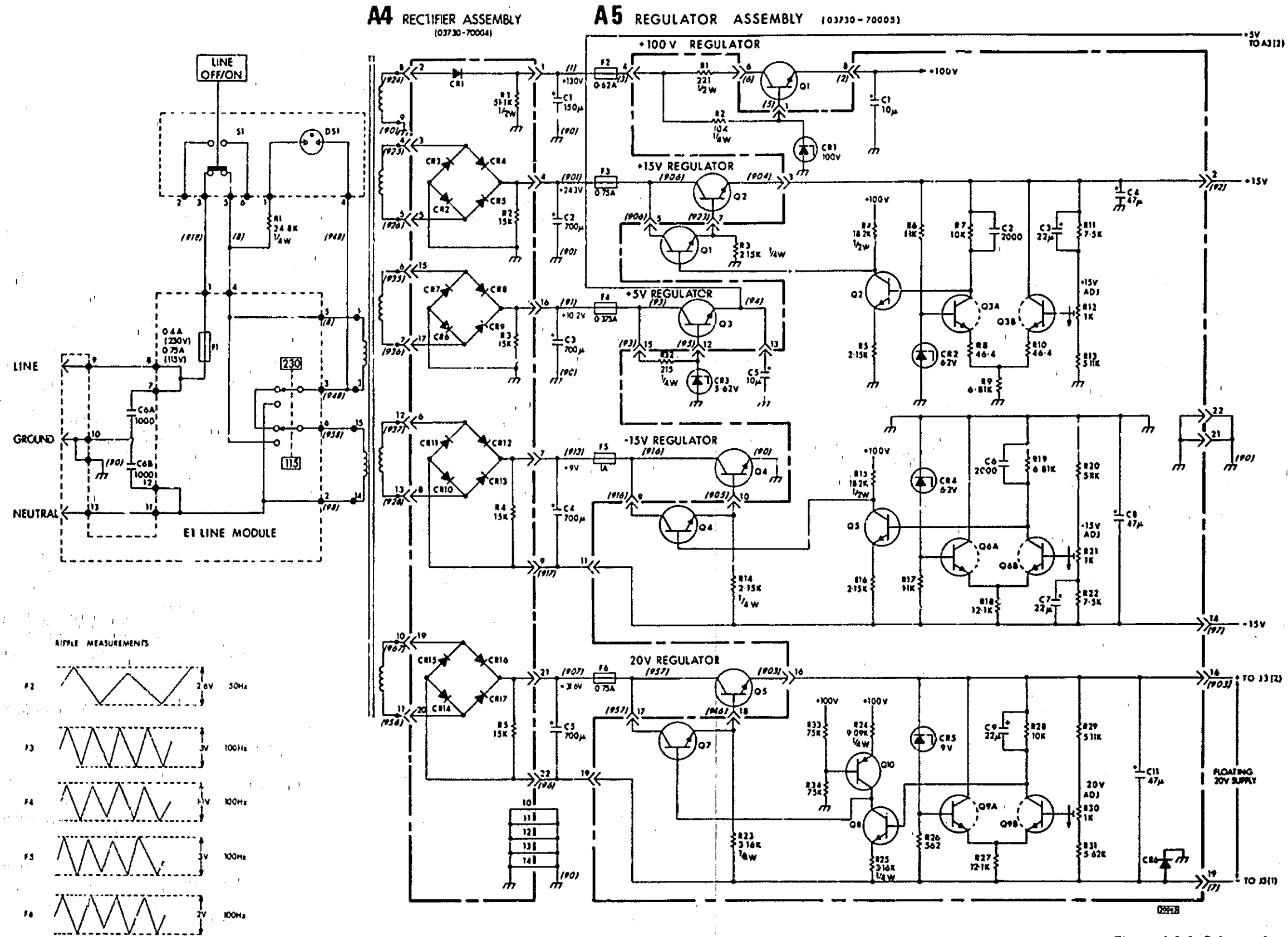

Figure A4-4 Schematic - Assemblies A4 and A5

A4/A5

ASSEMBLY SERVICE SHEET A6 – Group Delay Equaliser

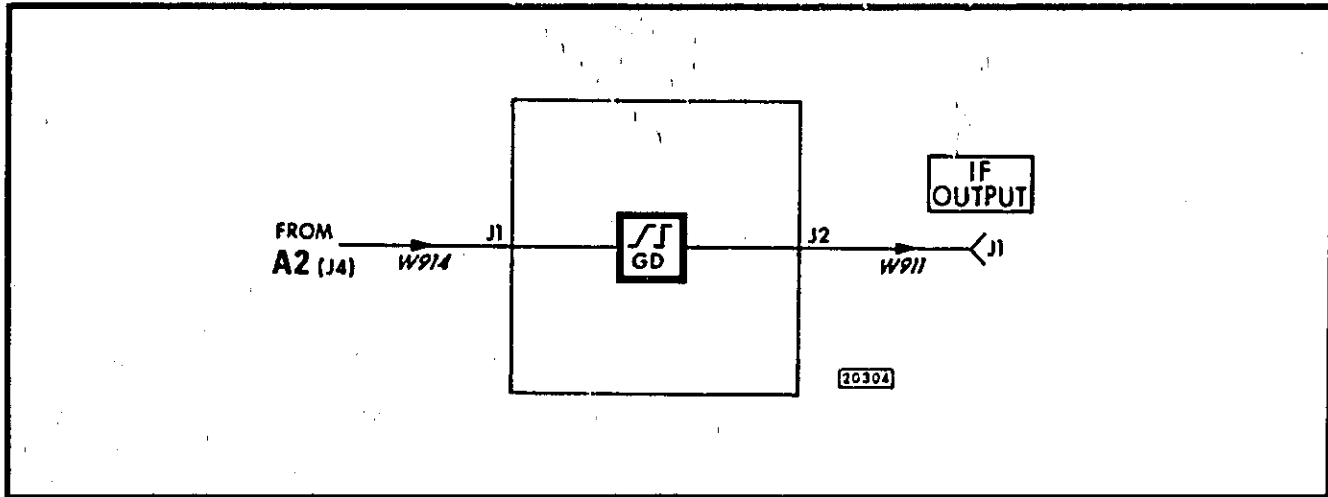

Figure A6-1 Simplified Block Diagram – Assembly A6

A6-1 CIRCUIT DESCRIPTION

A6-2 The A6 assembly is an all-pass network which equalises the Converter group delay characteristic. Group delay non-linearities are introduced mainly by the IF amplifier A2 in the standard instrument and both the A2 and A7 IF amplifiers in the Option 010 instrument.

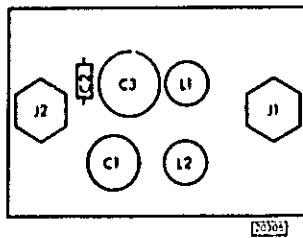
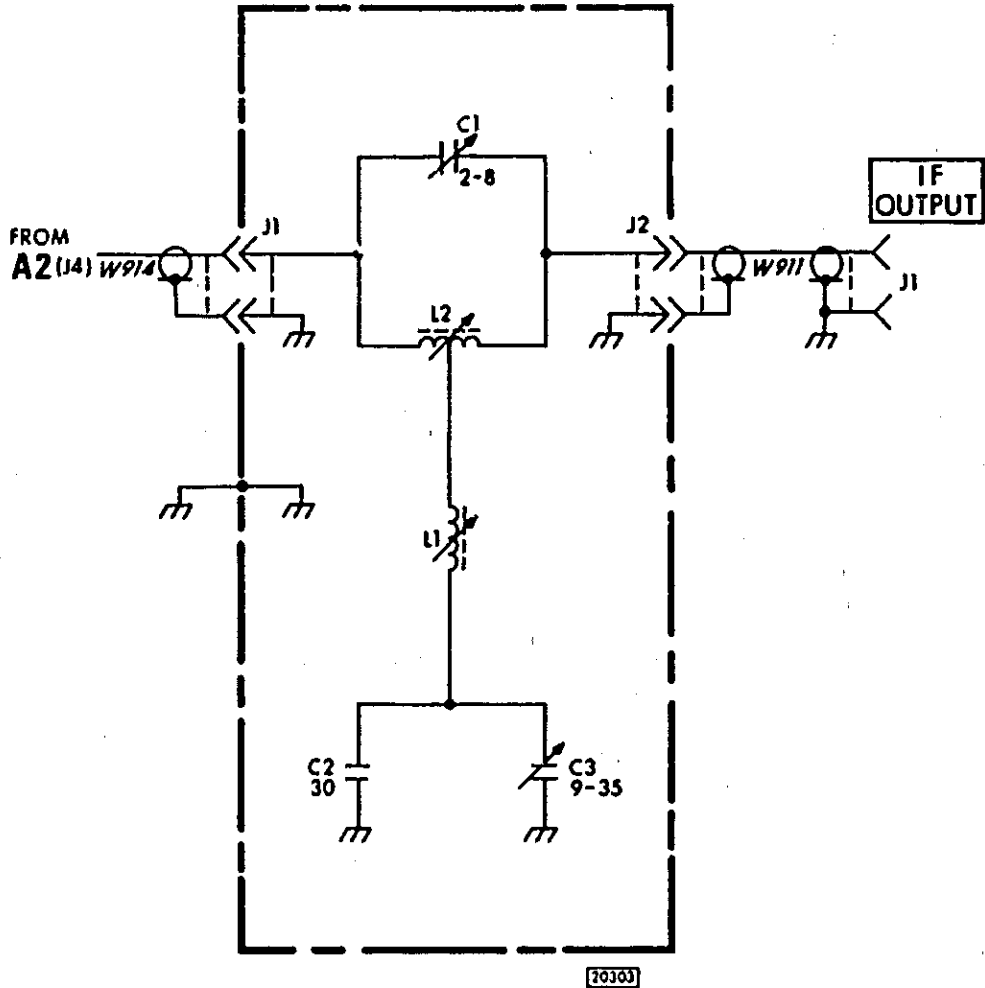

Figure A6-2 Component Location — A6

A6 GROUP DELAY EQUALISER (03730-70036)



A6

Figure A6-3 Schematic - Assembly A6

ASSEMBLY SERVICE SHEET A7 – IF Amplifier (Option 010)

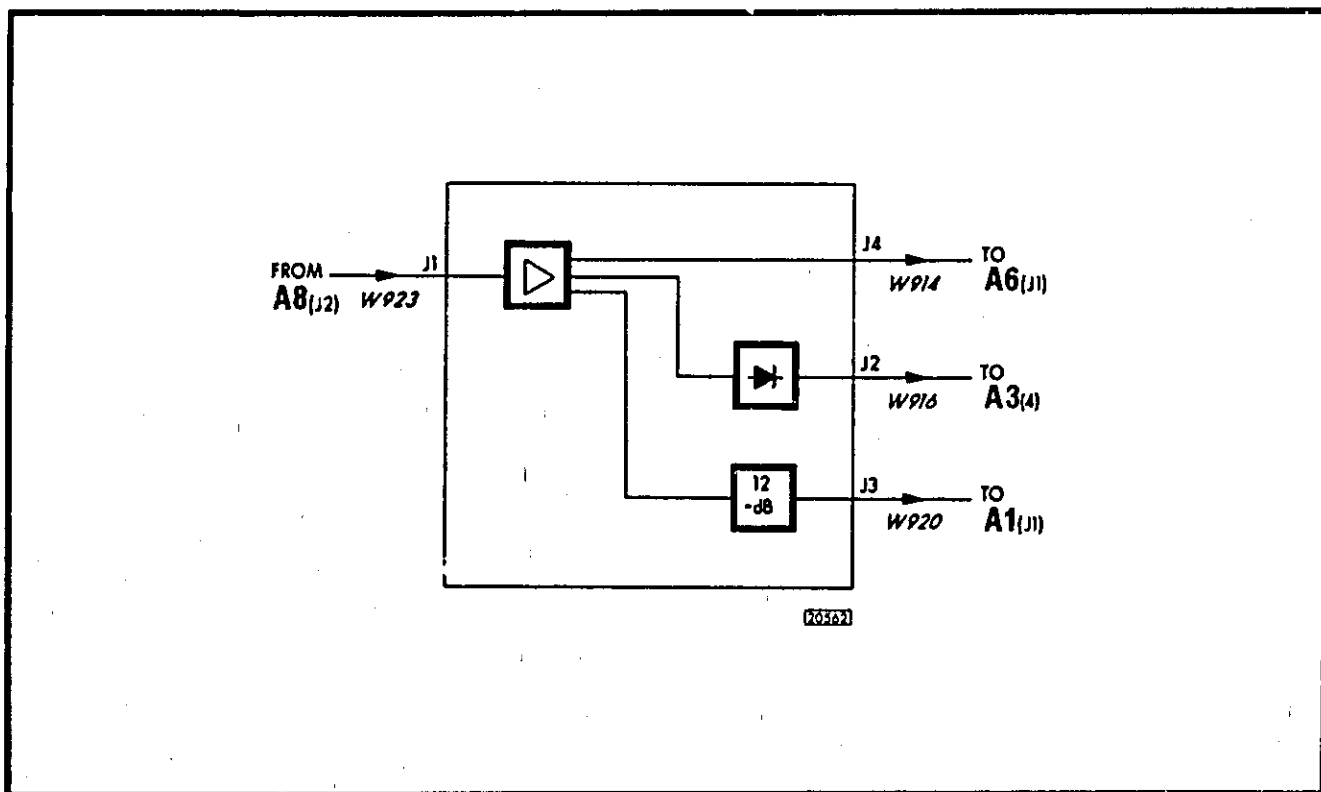

Figure A7-1 Simplified Block Diagram – Assembly A7

A7-1 CIRCUIT DESCRIPTION

A7-2 The optional IF amplifier reduces the minimum RF input level required to give an IF output level sufficient to operate an *hp* MLA to -40dBm.

A7-3 The IF input to the amplifier is taken from the J2 socket on the attenuator, assembly A8. The amplifier, comprising grounded base transistors Q1 to Q7, has a flat frequency response. Amplitude flatness over the band 45 to 95MHz is adjusted by test select resistors R11 and R13, and by variable capacitor C38.

A7-4 The main IF output from Q7 collector is taken via the output socket J4 to the group delay equaliser. A second output from Q7 is fed through a 12dB coupler formed by T8 and associated components and then, via the output socket J3, to the discriminator for use in the AFC circuitry.

The coupler ensures that the main IF output is not loaded by the discriminator.

A7-5 A secondary output from the IF amplifier is derived from the collector of Q6 and is coupled by T7 to a high impedance detector Q8. The detector provides a voltage in proportion to the IF level at Q6 collector and is used to drive the level detector circuit on assembly A3.

A7-6 Resistors R22 to R41, and capacitors C16 to C37 are filter components for the +15V and -15V supplies.

A7-7 ADJUSTMENT PROCEDURE

A7-8 This procedure should be carried out after the board has been repaired or if the group delay or flatness are out of specification. Note that considerable changes in flatness will occur as the

temperature changes. Therefore, the final flatness should be checked after 20 minutes warm-up, and with the instrument as near as possible in the normal operating condition, ie, with all the covers fitted.

A7-9 Set up an MLA to measure simultaneously back-to-back IF amplitude response and group delay. With 10dB attenuation in each of the MLA transmitter and receiver IF attenuators, calibrate the IF amplitude response display for 0.1dB/cm and the group delay display for 1ns/cm. Record the displays (take a polaroid photograph or trace the waveforms) for future reference.

A7-10 Connect the MLA transmitter IF output to A7J1 on the 3730A. Connect A7J4 to the MLA receiver IF input. Insert extra attenuation in the MLA transmitter IF attenuator until an on-scale reading is obtained on the IF level meter on the MLA receiver. The A7 IF amplifier gain is equal to the extra attenuation inserted. This should be 27dB.

A7-11 Adjust A7C38 for the best displayed flatness.

Compare the display with that of the back-to-back measurement to get the true response of the A7 amplifier. The IF amplitude response should be better than 0.15dB, and the group delay better than 1ns. A7R11 and A7R13 may be selected from values between 120 and 160 Ω to achieve this flatness. Note that A7R13 is a special temperature coefficient resistor.

A7-12 Now connect A7J3 to the MLA receiver IF input and adjust the MLA transmitter IF attenuator until an on-scale reading is obtained on the MLA receiver. The difference between this setting on the IF attenuator and that on the back-to-back measurement gives the gain at the auxiliary output A7J3. This should be 14 \pm 2dB.

A7-13 Measure the return loss at A7J4 using an MLA and a 75 Ω hybrid. If necessary adjust A7L2 to achieve a return loss of better than 29dB.

A7-14 Measure the return loss at A7J1 using an MLA and a 75 Ω hybrid. This should be better than 23dB.

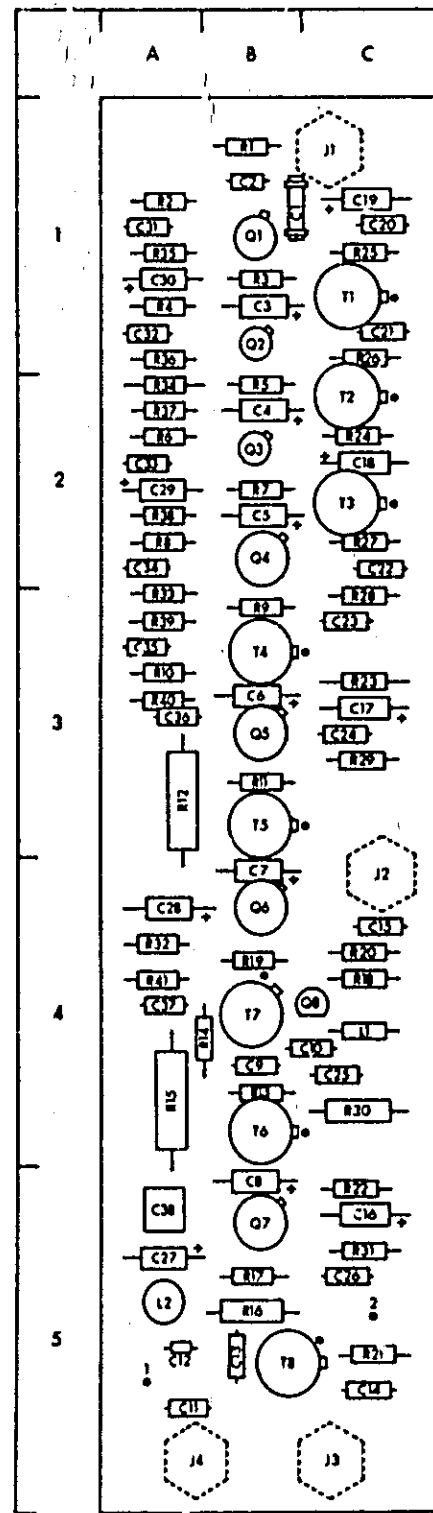

Figure A7-2 Component Location and Grid Reference - A7

REF DESIG	GRID LOC	REF DESIG	GRID LOC		
C1	B-1	J1	C-1		
C2	B-1	J2	C-4		
C3	B-1	J3	C-5		
C4	B-2	J4	A-5		
C5	B-2	L			
C6	B-3				
C7	C-4				
C8	B-5				
C9	B-4				
C10	C-4				
C11	A-5				
C12	A-5				
C13	B-5				
C14	C-5				
C15	C-4	O			
C16	C-5				
C17	C-3				
C18	C-2				
C19	C-1				
C20	C-1				
C21	C-1				
C22	C-2				
C23	C-3	Q			
C24	C-3				
C25	C-4				
C26	C-5				
C27	A-5				
C28	A-4				
C29	A-2				
C30	A-1				
C31	A-1				
C32	A-1			R	
C33	A-2				
C34	A-2				
C35	A-3				
C36	A-3				
C37	A-4				
C38	A-5				
R1	B-1	T			
R2	A-1				
R3	B-1				
R4	A-1				
R5	B-2				
R6	A-2				
R7	B-2				
R8	A-2				
R9	B-3				
R10	A-3				
R11	B-3	T1	C-1		
R12	A-3	T2	C-2		
R13	B-4	T3	C-3		
R14	B-4	T4	B-3		
R15	A-4	T5	B-3		
R16	B-5	T6	B-4		
R17	B-5	T7	B-4		
R18	C-4	T8	9-5		
R19	B-4				
R20	C-4				
R21	C-5				
R22	C-5				
R23	C-3				
R24	C-2				
R25	C-1				
R26	C-1				
R27	C-2				
R28	C-3				
R29	C-3				
R30	C-4				
R31	C-5				
R32	A-4				
R33	A-3				
R34	A-2				
R35	A-1				
R36	A-1				
R37	A-2				
R38	A-2				
R39	A-3				
R40	A-3				
R41	A-4				

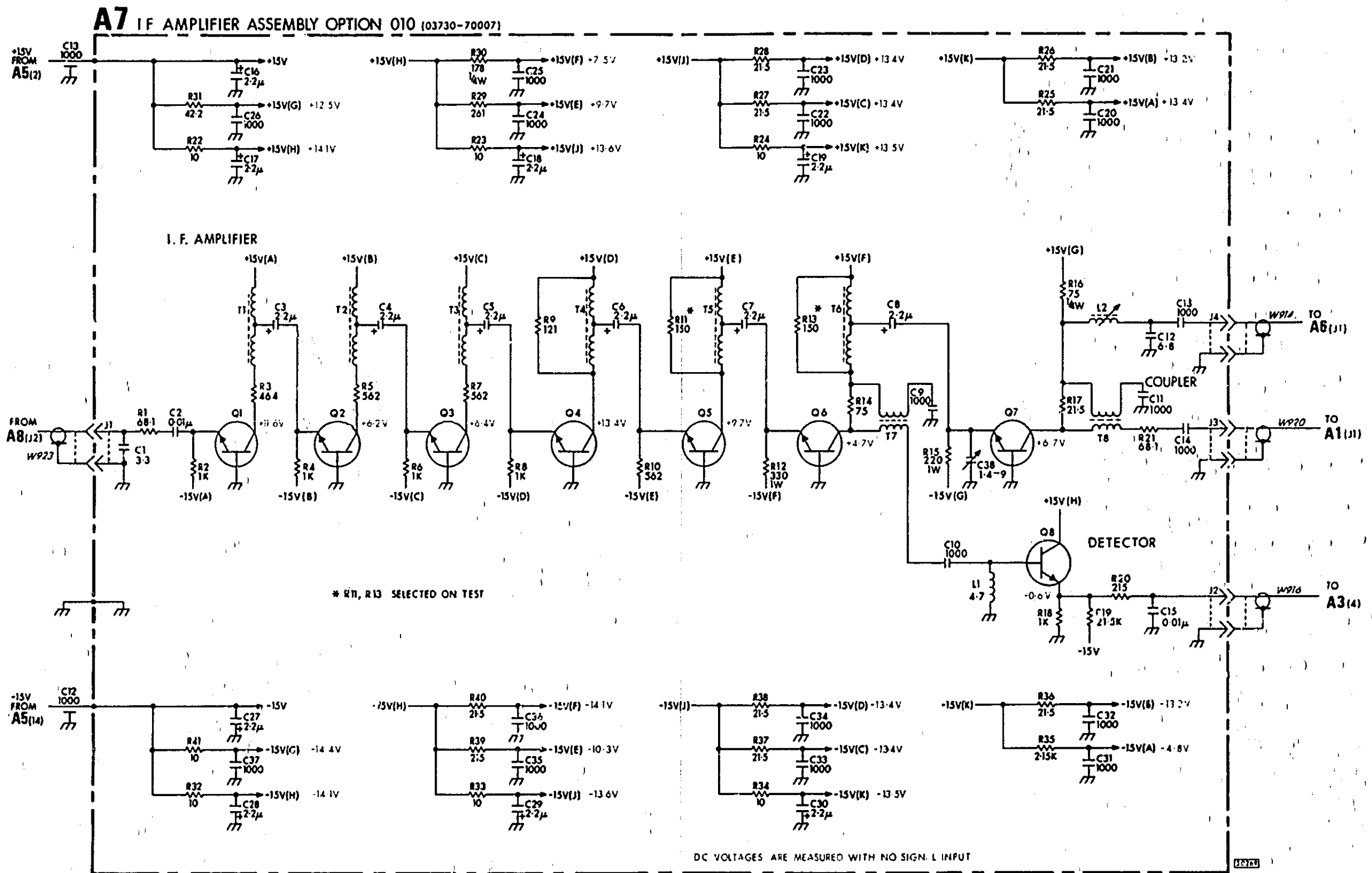

Figure A7-3 Schematic - Assembly A7

A7

ASSEMBLY SERVICE SHEET A8 – IF Attenuator (Option 010)

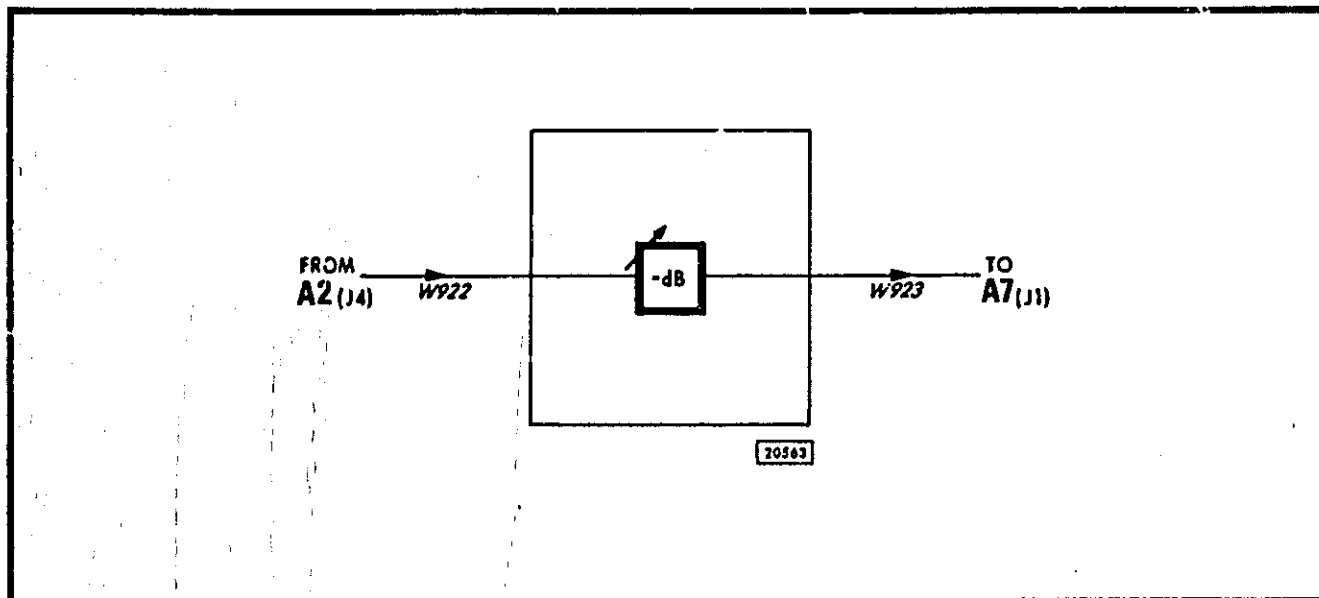

Figure A8-1 Simplified Block Diagram – Assembly A8

A8-1 CIRCUIT DESCRIPTION

A8-2 This assembly is fitted to Option 010 Down Converters only and is a five-section pushbutton attenuator, adjustable in 1dB steps from 0 to 25dB.

A8-3 Attenuation is provided by a configuration of resistors, eg, R1, R2 and R3, being connected in or out of the circuit by means of front-panel pushbutton switches.

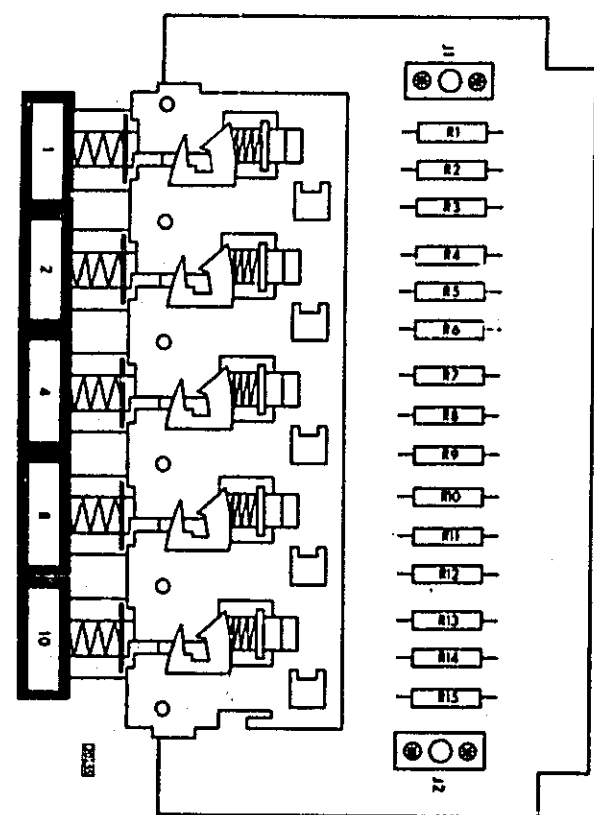

Figure A8-2 Component Location - A8

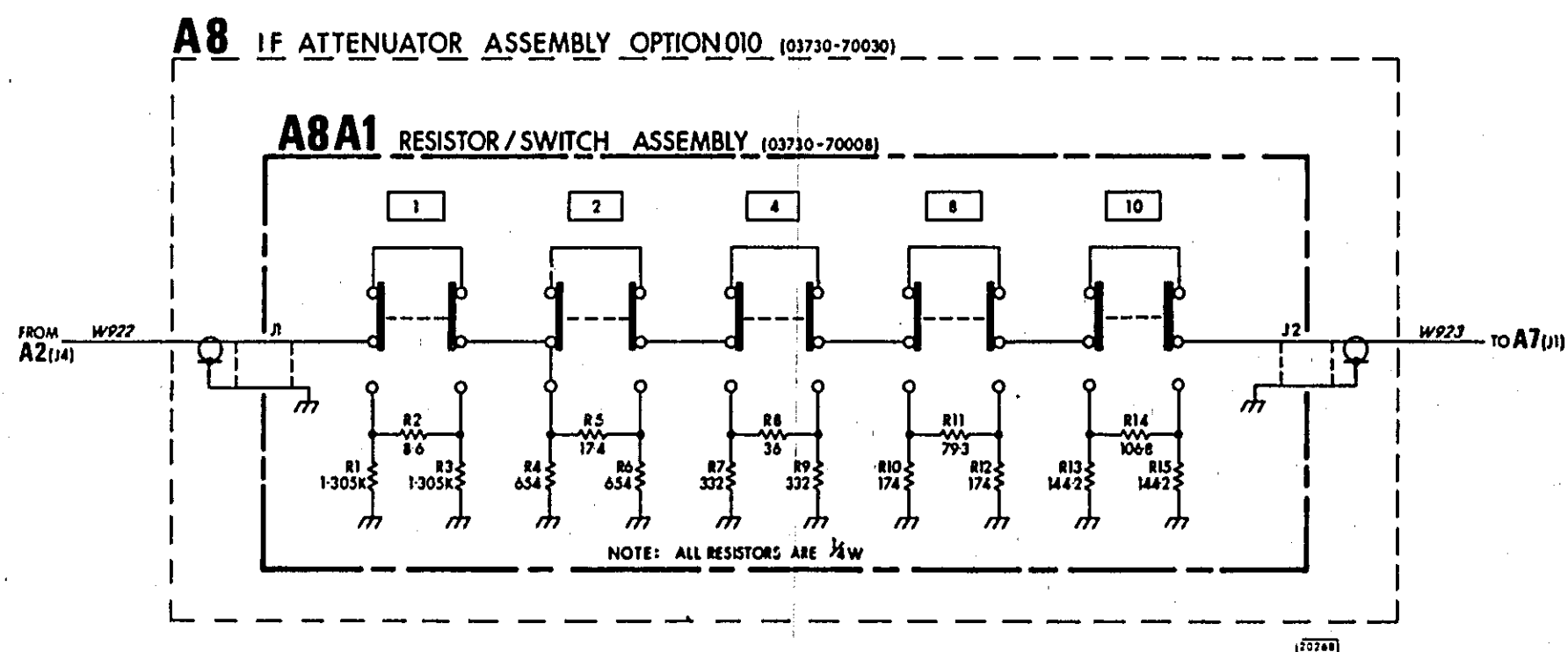

Figure A8-3 Schematic - Assembly A8

A8

SECTION VII MANUAL CHANGES

7-1 INTRODUCTION

7-2 This manual applies directly to instruments having serial numbers between 1316U-00261 and 1316U-00270. For instruments with serial numbers between 1144U and 1316U-00260, refer to the manual backdating information given in this section. For instruments with serial numbers higher than 1316U-00270, refer to the manual updating information given in the Manual Changes supplement supplied, if required, with this manual.

7-3 MANUAL BACKDATING

Serial Prefix or Number	Make Manual Changes
1316U 00201 to 1316U 00260	1
1231U 00161 to 1316U 00200	1, 2
1231U 00151 to 1231U 00160	1, 2, 3
1228U	1, 2, 3, 4
1222U	1, 2, 4, 5
1210U	1, 2, 4, 5, 6
1144U	1, 2, 4, 5, 6, 7

CHANGE 1

Table 5-1 Replaceable Parts

Change: A2R9 to 0757-0339 R. FXD 82.5 OHM 1% 1/8W
 A5C9 to 0160-2225 C. FXD 2000 pF 5% 300WVDC
 A5C10 to 0180-0228 C. FXD 22UF 10% 15WVDC
 A7R9 to 0757-0399 R. FXD 82.5 OHM 1% 1/8W

Figure A2-3, Schematic Diagram — Assembly A2

Change: A2R9 to 82.5 OHM

Figure A4-3, Component Location, A5

Add: A5C10 as shown in Figure 7-1.

Figure A4-3, Grid Reference, A5

Add: C10 D-2

Figure A4-4 Schematic Diagram — Assembly A4/A5

Add: A5C10 to Floating 20V Supply as shown in Figure 7-2.

Change: A5C9 to 2000PF

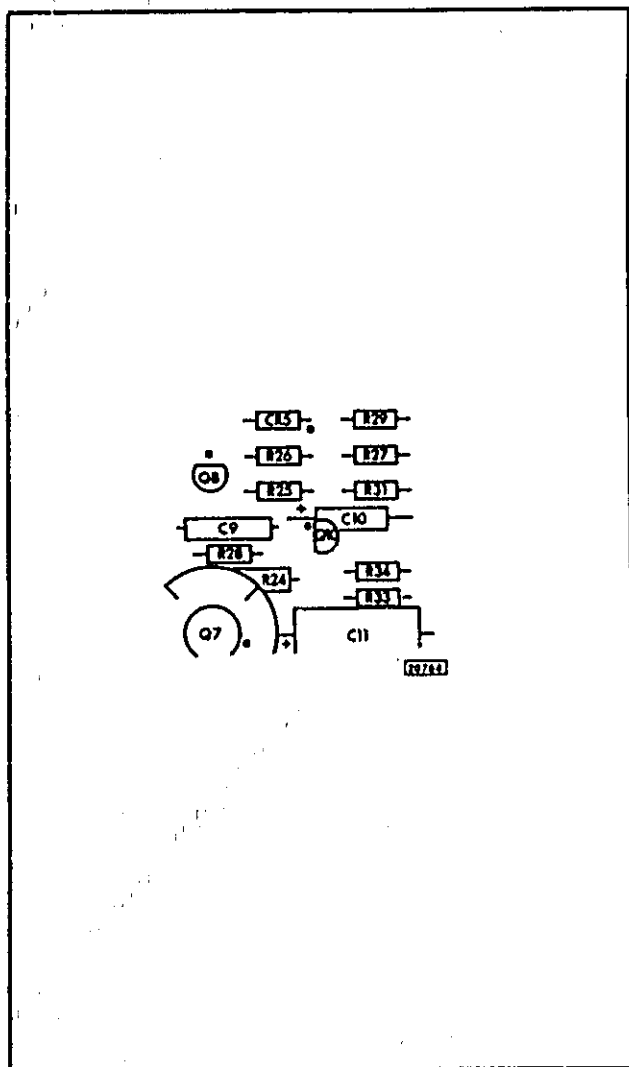

Figure 7-1 Part of Component Location, A5

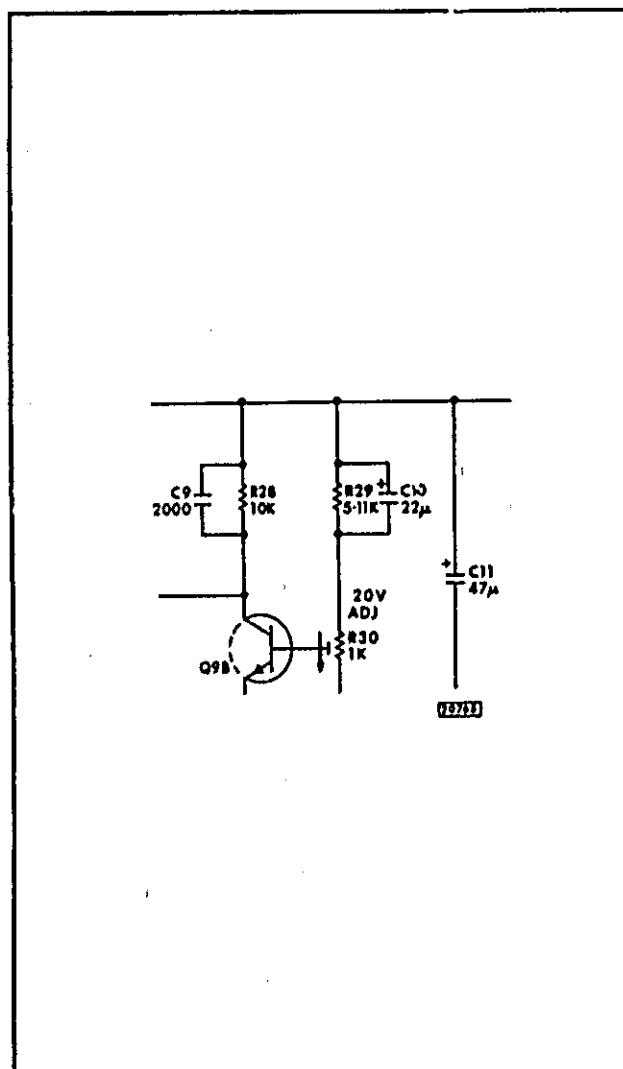

Figure 7-2 Part of Schematic Diagram
- Assembly A4/A5

Figure A7-3, Schematic Diagram - Assembly A7
Change: A7R9 to 82.5 OHM

CHANGE 2 Table 5-1 Replaceable Parts
Change: A7Q2 to 1854-0073 XSTR SI NPN
A7Q3 to 1854-0073 XSTR SI NPN

CHANGE 3 Table 5-1 Replaceable Parts
Change: A3R24 to 0757-0279 R FXD 3.16K OHM 1% 1/8W
A3R28 to 0757-0279 R FXD 3.16K OHM 1% 1/8W

Figure A3-3 Schematic Diagram — Assembly A3

Change: A3R24 to 3.16K OHM
A3R28 to 3.16K OHM

CHANGE 4 Table 5-1 Replaceable Parts
Add: CR1 1901-0003 DIO GE
Delete: A5CR6 1901-0003 DIO GE

Figure G1-3 Assembly and Test Point Locations (Bottom View)

Add: CR1 between XA5(20) and XA5(22)

Figure G2-3 Assembly and Test Point Locations (Bottom View)

Add: CR1 between XA5(20) and XA5(22)

Figure A4-3 Component Location and Grid Reference, A5

Delete: CR6

Figure A4-4 Schematic Diagram — Assemblies A4/A5

Delete: A5CR6

Add: CR1 between XA5(20) and 0V, anode to XA5(20)

CHANGE 5 Table 5-1 Replaceable Parts

Change: A2R13 to 0757-0284 R FXD 150 OHM 1% 1/8W
A3R21 to 0698-4266 R FXD 3.3K OHM 5% 1/8W
A3R24 to 0698-3154 R FXD 4.22K OHM 1% 1/8W
A3R27 to 0757-0441 R FXD 8.25K OHM 1% 1/8W
A3R28 to 0698-3154 R FXD 4.22K OHM 1% 1/8W
A7R13 to 0757-0284 R FXD 150 OHM 1% 1/8W

Figure A2-3 Schematic Diagram — Assembly A2

Change: A2R13 to 150 OHM

Figure A3-3 Schematic Diagram — Assembly A3

Change: A3R21 to 3.3K OHM
A3R24 to 4.22K OHM
A3R27 to 8.25K OHM
A3R28 to 4.22K OHM

Figure A7-3 Schematic Diagram — Assembly A7

Change: A7R13 to 150 OHM

CHANGE 6 Table 5-1 Replaceable Parts

Change: A1R17 to 0757-0280 R FXD 1K OHM 1% 1/8W
A1R37 to 0757-0280 R FXD 1K OHM 1% 1/8W
A2Q2 to 1854-0073 XSTR SI NPN

A2Q3 to 1854-0073 XSTR SI NPN
A5CR2 to 1902-3097 DIO BKDN 5.23V 2% 400MW
A5CR3 to 1902-3097 DIO BKDN 5.23V 2% 400MW
A5R6 to 0757-0421 R FXD 825 OHM 1% 1/8W
A5R13 to 0698-3153 R FXD 3.83K OHM 1% 1/8W
A5R17 to 0757-0421 R FXD 825 OHM 1% 1/8W
A5R20 to 0698-3153 R FXD 3.83K OHM 1% 1/8W

Figure A1-3 Schematic Diagram – Assembly A1

Change: A1R17 to 1K OHM
A1R37 to 1K OHM

Figure A4-4 Schematic Diagram – Assemblies A4/A5

Change: A5CR2 to 5.23V
A5CR3 to 5.23V
A5R6 to 825 OHM
A5R13 to 3.83K OHM
A5R17 to 825 OHM
A5R20 to 3.83K OHM

CHANGE 7 Table 5-1 Replaceable Parts

Change: A1R35 to 0698-3132 R FXD 261 OHM 1% 1/8W
A3CR2 to 1902-0786 DIO BKDN 9V 5% 500MW

Add: A3CR3 1901-0040 DIO Si
A3Q9 1854-0071 XSTR SI NPN
A3R31 0757-0290 R FXD 6.19K OHM 1% 1/8W

Change: A3R32 to 2100-2489 R VAR 5K OHM 10% 1/2W
A3R33 to 0698-3157 R FXD 19.6K OHM 1% 1/8W
A3R34 to 0757-0452 R FXD 27.4K OHM 1% 1/8W
A3R35 to 0757-0419 R FXD 681 OHM 1% 1/8W

Figure A1-3 Schematic Diagram – Assembly A1

Change: A1R35 to 261 OHM

Figure A3-2 Component Location, A3

Add: CR3, Q9 and R31 as shown in Figure 7-3.

Figure A3-2 Grid Reference, A3

Add: CR3 C-2
Q9 C-1
R31 C-1

Figure A3-3 Schematic Diagram – Assembly A3

Change: Reference Circuit as shown in Figure 7-4.

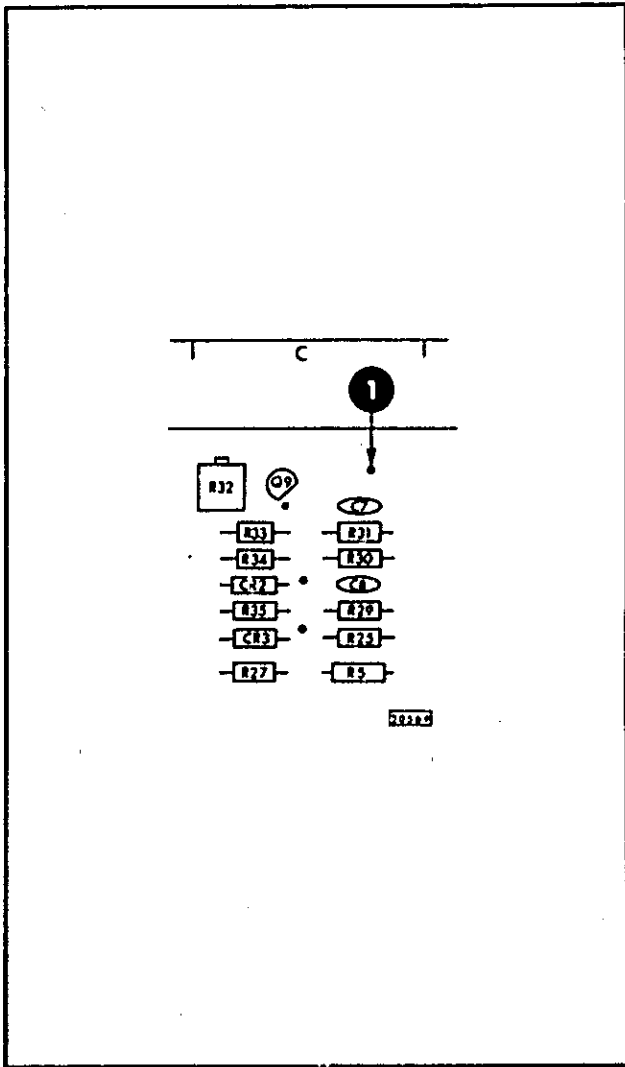

Figure 7-3 Part of Component Location, A3

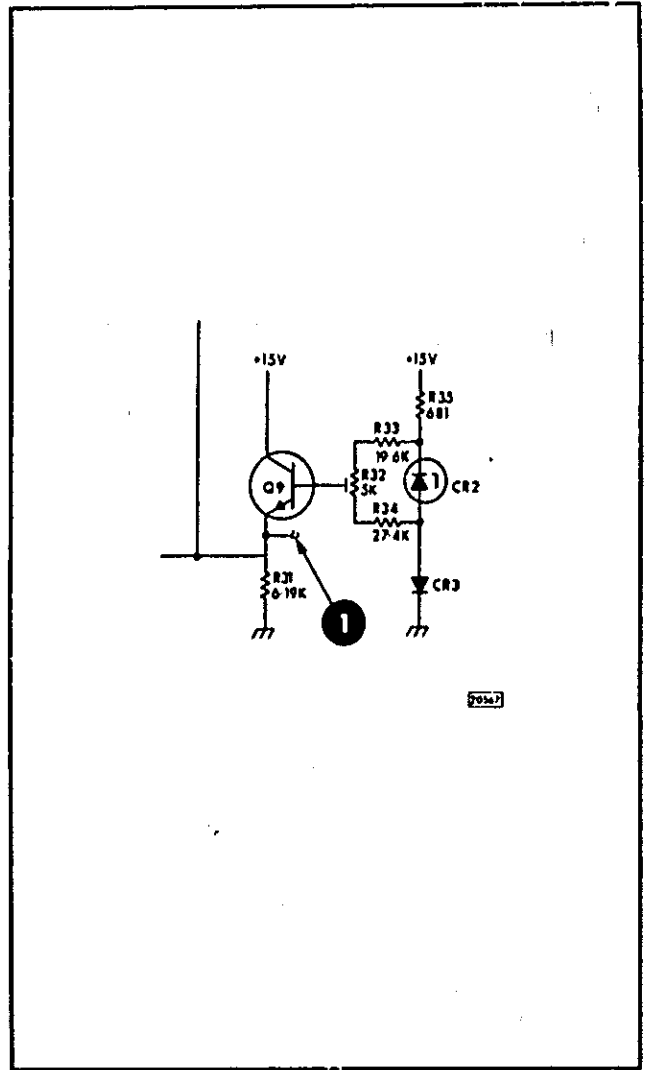

Figure 7-4 Part of Schematic Diagram
- Assembly A3

MANUAL CHANGES

MANUAL IDENTIFICATION

Model Number: 3730A 0&S
Date Printed: June 1974
Part Number: 03730-95004

This supplement contains important information for correcting manual errors and for adapting the manual to instruments containing improvements made after the printing of the manual.

To use this supplement

Make all ERRATA corrections

Make all appropriate serial number related changes indicated in the tables below.

Serial Prefix or Number	Make Manual Changes
1439U-00341	1
1439U-00361	1-2
1505U-00381	1-3
1505U-00401	1-4
1505U-00411	1-5
1541U-00441	1-6

Serial Prefix or Number	Make Manual Changes
1602U-00480	1-7
1626U-00506	1-8
1626U-00536	1-9
1647U-00561	1-10
1831U-00811	1-11

• NEW ITEM

ERRATA

Page 1-3, Paragraph 1-20:
Delete Rack Mounting Kit.

Page 4-1, Table 4-1, Power Supply Adjustments:
Test Point A5(13) voltage should be $+5V \pm 0.15V$.

Table 5-1:
Change R2 to 62rA Part Number 2110-0011.

Page 5-4, Table 5-1:
Change MP10 to Part Number 03730-70048 Assembly Deck L.H.
Change MP14 to Part Number 03730-70049 Assembly REAR WALL.
Change MP15 to Part Number 03730-70050 Assembly Lower Deck.
Change C1 C. FXD 150 μ F 200V to C. FXD 40 μ F 450WVDC Part Number 0180-0024.

NOTE

Manual change supplements are revised as often as necessary to keep manuals as current and accurate as possible. Hewlett-Packard recommends that you periodically request the latest edition of the supplement. Free copies are available from all HP offices. When requesting copies quote the manual identification information from your supplement or the model number and print date from the title page of the manual.

28th Jan 80

Page 1 of 6

HEWLETT  PACKARD

ERRATA (Cont'd):

Page 5-5, Table 5-1:

Change A5C20 to C. FXD 56pF Part Number 0160-4527.

Page 5-6, Table 5-1:

Change A2C38, 0121-0451 to C. VAR Part Number 0121-0602.

* Page 5-7, Table 5-1:

Change A3Q2, A3Q4, A3Q7, A3Q12 to Part Number 1854-0870.

Page 5-10, Table 5-1:

Change A7C38, 0121-0451 to C. VAR Part Number 0121-0602.

Page 6-7:

Add Note below Table G1-1:

NOTE: *A 75/50Ω Matching Pad should be used with the HP 432A Power Meter when measuring power levels at monitor points 4 and 5.*

Page 6-12:

Add Note below Table G2-1.

NOTE: *A 75/50Ω Matching Pad should be used with the HP 432A Power Meter when measuring power levels at monitor points 4, 5, 6 and 7.*

Page 6-31, Figure A4-3:

Change + SIGN to opposite end of A5C9.

Page 6-31, Figure A4-4:

Change F2 to 0.062A.

CHANGE 1

Page 5-9, Table 5-1:

Change A5R32 R. FXD 215 Ω to R. FXD 470 Ω 5% $\frac{1}{2}$ W Part Number 0683-4715.

CHANGE 2

Table 5-1:

Change A5C9 C. FXD 22 μ F to C. FXD 2.2 μ F Part Number 0180-0197.

CHANGE 3

Page 5-4, Table 5-1:

Change MP10 ASSY DECK L.H. to Part Number 03730-70051.

Change MP11 DECK SIDE to Part Number 03730-10040.

Change MP12 HOUSING PLUG-IN to Part Number 03730-10038.

CHANGE 4

Page 5-9, Table 5-1:

Change A5R30 R. VAR 1K Ω to R. VAR 2K Ω Part Number 2100-2521.

Page 6-31, Figure A4-4:

Change A5R30 to 2K Ω .

CHANGE 5

Page 5-7, Table 5-1:

Change A3R22 to R. FXD 2.15K 1% $\frac{1}{2}$ W Part Number 0698-0084.

Page 6-27, Figure A3-3:

Change R22 to 2.15K Ω .

CHANGE 6

Page 5-4, Table 5-1:

Change C6 C. FXD DUAL 1000pF 1000 WVDC Part Number 0160-2657 to

C. FXD DUAL 1000pF 250WVAC Part Number 0160-3561.

Change E? MIXER Part Number 0960-0174 to Part Number 0960-0451.

Page 5-5, Table 5-1:

Change W910 Part Number 03730-70010 to Part Number 03730-70052.

Change W913 Part Number 03730-70013 to Part Number 03730-70053.

CHANGE 7

Page 5-4, Table 5-1:

Delete E1 MODULE PWR	Part Number 5060-1196.
Add J5 CONNECTOR AC	Part Number 1251-2357.
F1 FUSEHOLDER	Part Number 2110-0464.
F1 FUSE CAP	Part Number 2110-0465.
F1 LOCKWASHER	Part Number 2190-0054.
F1 NUT	Part Number 2950-0054.

Page 6-31, Figure A4-4:

Delete ALL REFERENCE to E1 and remove dotted line from around what was E1.

CHANGE 8

Page 5-4, Table 4-1:

Change MP9 to Part Number 03730-70056.

Page 5-5, Table 5-1:

Delete S1 SW P.B. SPDT LIGHTED LENS WHITE	Part Number 3101-1248.
Delete W924 ASSY CBL	Part Number 03730-70024.
Add W200 ASSY CBL POWER	Part Number 03730-70054.
SW. PB. DPDT	Part Number 3101-1395 (S1).
R. FXD 34.8K 1% $\frac{1}{2}$ W	Part Number 0698-4736 (R1).
CBL SHIELDED	Part Number 8120-1593.

Page 6-31, Figure A4-4:

Change as per Figure A4-4a provided.

CHANGE 9

Page 5-8, Table 5-1:

Change A3R32 R. VAR 200 Ω to R. VAR 500 Ω 10% $\frac{1}{2}$ W Part Number 2100-2574.

Page 6-27, Figure A3-3:

Change A3R32 to 500 Ω .

CHANGE 10

Page 5-6, Table 5-1:

Delete A1R15.

Page 6-19, Figure A1-5:

Replace A1R15 by wire link showing Q4 base connected to ground.

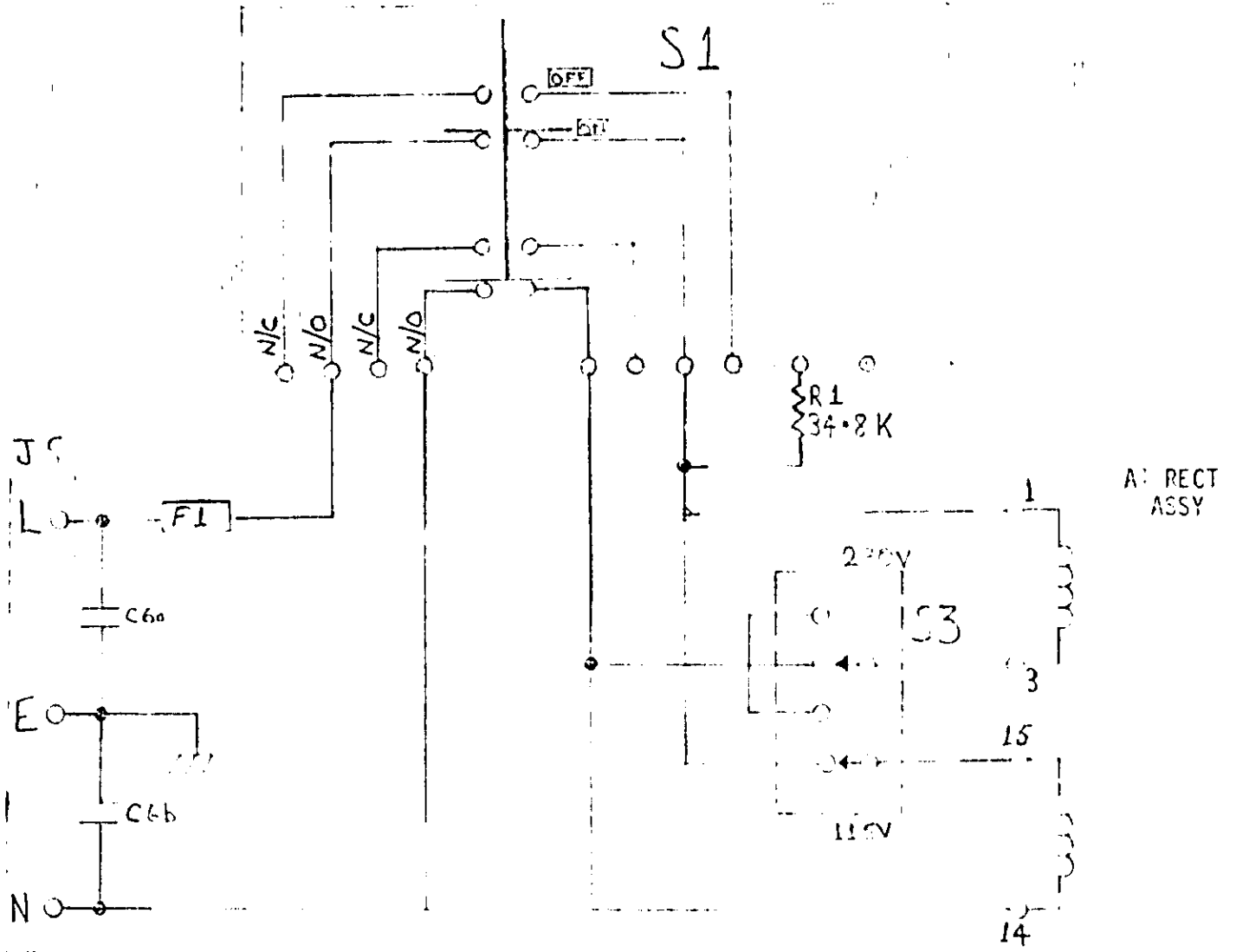

Model No. 3730A

03730-95004

CHANGE 11

Page 5-5, Table 5-1:

Change A1C17 to C. FXD 10pF 500WVDC Part Number 0160-2257.