

Errata

Title & Document Type: 3480C / 3480D Digital Voltmeter Operating and Service Manual

Manual Part Number: 03480-90006

Revision Date: July 1975

About this Manual

We've added this manual to the Agilent website in an effort to help you support your product. This manual provides the best information we could find. It may be incomplete or contain dated information, and the scan quality may not be ideal. If we find a better copy in the future, we will add it to the Agilent website.

HP References in this Manual

This manual may contain references to HP or Hewlett-Packard. Please note that Hewlett-Packard's former test and measurement, life sciences, and chemical analysis businesses are now part of Agilent Technologies. The HP XXXX referred to in this document is now the Agilent XXXX. For example, model number HP8648A is now model number Agilent 8648A. We have made no changes to this manual copy.

Support for Your Product

Agilent no longer sells or supports this product. You will find any other available product information on the Agilent Test & Measurement website:

www.agilent.com

Search for the model number of this product, and the resulting product page will guide you to any available information. Our service centers may be able to perform calibration if no repair parts are needed, but no other support from Agilent is available.



Agilent Technologies



OPERATING AND SERVICE MANUAL

Manual Part No. 03480-90006
(Complete manual including binder)

Binder Part No. 03480-90005
(Includes Cover Inserts)

3480C/D Manual Loose Leaf Pages Only Part No. 03480-90004

Microfiche Part No. 03480-90054

MODEL 3480C/D DIGITAL VOLTMETER

Copyright Hewlett-Packard Company 1973
P.O. Box 301, Loveland, Colorado, 80537 U.S.A.

HEWLETT  PACKARD

CERTIFICATION

Hewlett-Packard Company certifies that this instrument met its published specifications at the time of shipment from the factory. Hewlett-Packard Company further certifies that its calibration measurements are traceable to the U.S. National Bureau of Standards, to the extent allowed by the Bureau's calibration facility.

WARRANTY AND ASSISTANCE

All Hewlett-Packard products are warranted against defects in materials and workmanship. This warranty applies for one year from the date of delivery, or, in the case of certain major components listed in the operating manual, for the specified period. We will repair or replace products which prove to be defective during the warranty period provided they are returned to Hewlett-Packard. No other warranty is expressed or implied. We are not liable for consequential damages.

If this product is sold as part of a Hewlett-Packard configured instrument system, the system warranty then applies to this product in lieu of the standard product warranty.

Service contracts or customer assistance agreements are available for Hewlett-Packard products that require maintenance and repair on-site.

For any assistance, contact your nearest Hewlett-Packard Sales and Service Office.

TABLE OF CONTENTS

Section	Page	Section	Page
I. GENERAL INFORMATION	1-1	3-36. Sample/hold Operating Characteristics ..	3-1
1-1. Introduction	1-1	3-43. Isolated BCD Output Option 004	3-5
1-4. Specifications	1-1	3-50. 2070A Data Logger	3-6
1-6. Options	1-1		
1-7. Sample/hold Option 001	1-1	Section	Page
1-9. Isolated BCD Output, Option 004	1-1	IV. THEORY OF OPERATION	4-1
1-11. Accessories Supplied	1-1	4-1. Introduction	4-1
1-13. Accessories Available	1-1	4-3. Plug-in	4-1
1-17. Instrument and Manual Identification	1-1	4-5. Polarity Amplifiers	4-1
		4-9. Polarity Indicator Circuits	4-2
Section	Page	4-14. Comparator Amplifier	4-2
II. INSTALLATION AND INTERFACING	2-1	4-17. Sample Generator, with Single Channel Plug-ins	4-3
2-1. Introduction	2-1	4-19. Sample Oscillator and Reset Amplifier ..	4-3
2-3. Initial Inspection	2-1	4-22. Hold and Trigger Amplifiers	4-3
2-5. Power Requirements	2-1	4-25. Timing Sequence Logic	4-3
2-7. Power Cords and Receptacles	2-1	4-27. Clock Circuits	4-4
2-9. Grounding Requirements	2-1	4-30. 18-Pulse Counter	4-4
2-11. Installation	2-1	4-32. Counter Decoding Logic	4-5
2-13. Bench Use	2-1	4-34. Digital-to-Analog Memory Logic	4-5
2-15. Rack Mounting	2-1	4-40. Digital-to-Analog Switches	4-7
2-17. Interface Connections	2-1	4-42. Series D/A Switches	4-7
2-18. Sample/hold Option 001	2-1	4-45. Shunt D/A Switches	4-7
2-20. Isolated BCD Output Option 004	2-1	4-48. Comparison Sequence	4-8
2-22. Remote Control	2-2	4-50. Display	4-8
2-24. Installation of Options	2-2	4-52. Overrange	4-8
2-26. Option 001, Sample/hold	2-2	4-54. Overload	4-8
2-28. S/H Installation, 3480C	2-2	4-56. Power Supplies	4-9
2-29. S/H Installation, 3480D	2-4	4-58. Range and Function Display	4-9
2-30. Option 004, Isolated BCD Output	2-5	4-60. Sample/hold Option 001	4-9
2-32. Repackaging for Shipment	2-6	4-62. Sample/hold Amplifier	4-9
		4-65. Polarity Amplifiers	4-9
Section	Page	4-68. Sample/hold Enable	4-9
III. OPERATING INSTRUCTIONS	3-1	4-70. Automatic Sampling	4-11
3-1. Introduction	3-1	4-72. External Trigger (Non-Delayed Mode) ..	4-11
3-3. Plug-in Unit Installation	3-1	4-74. External Trigger (Delayed Mode)	4-12
3-5. General Operating Conditions	3-1	4-76. Interface Circuits	4-12
3-6. Turn-on and Warm-up	3-1	4-78. Isolated BCD Output Option 004	4-12
3-8. Maximum Input Voltage	3-1		
3-10. Maximum Step Change in Input Voltage	3-1	Section	Page
3-15. Floating Measurements	3-2	V. MAINTENANCE	5-1
3-17. Overrange Measurements	5-3	5-1. Introduction	5-1
3-19. Overload Indication	3-3	5-3. Test Equipment Required	5-1
3-21. Sample Control (3482A, 3484A)	3-3	PERFORMANCE CHECKS	5-1
3-25. Sample/hold Operation (Option 001)	3-3	5-5. Scope of Checks	5-1
3-26. Sample/hold Interface Signals	3-3	5-7. Sample/hold Check (Option 001)	5-1
3-28. Sample/hold Selection	3-3	5-9. BCD Output Check (Option 004)	5-2
3-30. Sample/hold Off	3-3	5-11. Preliminary Information	5-3
3-32. Sample/hold O.A. Delay Off, External S/H Trigger	3-3	5-13. Power Supply Adjustment	5-3
3-34. Sample/hold On, Delay On, Any Trigger Source	3-4	5-15. Calibration Input	5-3
		5-18. Amplifier Zero Adj (All Except Option 001)	5-3

TABLE OF CONTENTS (Cont'd)

Section	Page	Section	Page
5-20. D/A Current Adjustments (All Except Option 001)	5-1	5-58. Sample/hold Amplifier Checks (Option 001)	5-9
5-22. Inverting Amp Gain Adj (All Except Option 001)	5-1	5-60. Sample/hold Polarity Amp Checks (Option 001)	5-9
5-24. Amplifier Zero Adjustment (Option 001)	5-5	5-62. Sample/hold Logic Checks (Option 001)	5-9
5-26. D/A Current Adjustments (Option 001)	5-6	5-64. Isolated BCD Output (Option 004)	5-9
5-28. Inverting Amp Gain Adj (Option 001)	5-6	5-67. Factory Selected Components	5-9
5-30. Sample/hold Delay Adjustment (Option 001)	5-6	5-69. A1R68	5-10
5-32. Troubleshooting	5-6	5-71. A3R2 and A3R3	5-10
5-34. Display Led Replacement	5-6	5-73. A3P17 and A3R19	5-10
5-35. Annunciator Led Replacement	5-6	5-75. A4R4 and A4R6	5-10
5-36. Access to Bottom of Master Board Ad	5-7		
5-37. Troubleshooting Trees	5-7	Section	Page
5-39. Power Supply Checks	5-7	VI. REPLACEABLE PARTS	6-1
5-41. Ground Circuits	5-7	5-1. Introduction	6-1
5-44. Amplifier Troubleshooting	5-7	5-4. Ordering Information	6-1
5-47. Non-Inverting Polarity Amplifier Gain Check	5-7	5-6. Non-Lated Parts	6-1
5-48. Inverting Polarity Amplifier Gain Check	5-7		
5-49. Comparator Amplifier Gain Check	5-8	Section	Page
5-50. +10 V Regulator Gain Check	5-8	VII. CIRCUIT DIAGRAMS	7-1
5-51. Memory Logic and D/A Switch Check	5-8	7-1. Introduction	7-1
5-54. Memory Logic Circuit Check	5-8	7-3. Notes	7-1
5-56. D/A Switch Check	5-9		

- APPENDICES
A. CODE LIST OF MANUFACTURERS
B. SALES AND SERVICE OFFICES
C. MANUAL BACKDATING CHANGES

LIST OF TABLES

Table	Page	Table	Page
1-1. Specifications	1-2	5-3. Numerical Information Printout	5-2
1-2. Typical Operating Characteristics	1-3	5-4. Range Printout	5-2
2-1. Format for Option 004	2-3	5-5. Function Printout	5-2
3-1. Modes of Sample/hold Operation	3-4	5-6. Polarity and Overload Printout	5-2
3-2. Minimum Bandwidth	3-4	5-7. Power Supply Voltages	5-3
3-3. Acquisition Time	3-4	5-8. D/A Current Adjustments	5-4
3-4. Ramp and Sine Wave Digitization	3-4		
3-5. Peak-to-Peak Noise	3-5	5-9. Calibration Check	5-5
3-6. Printer Information for BCD Output Option 004	3-6	5-10. D/A Current Adjustments (Option 001)	5-6
3-7. BCD Output	3-6	5-11. Power Supply Voltages	5-7
5-1. Required Test Equipment	5-1	5-12. Memory Logic and D/A Switch Check	5-9
5-2. Information Printed, Option 004	5-2	5-13. D/A Switch Voltages	5-9
		6-1. Replaceable Parts	6-2

LIST OF ILLUSTRATIONS

Figure	Page	Figure	Page
2-1. Power Cord Receptacles	2-1	5-4a. Waveforms	5-11
2-2. Sample/Hold Connections	2-2	5-4b. Waveforms	5-12
2-3. BCD Connections, J13	2-3	5-4c. Waveforms	5-13
2-4. Sample/Hold Board Connections, 3480C	2-4	5-5. Troubleshooting Tree A	5-15/5-16
2-5. Sample/Hold Board Connections, 3480D	2-5	5-6. Troubleshooting Tree B	5-17/5-18
2-6. Location of BCD Output Assembly	2-5	5-7. Troubleshooting Tree C	5-19/5-20
2-7. A9 Installation for BCD Option 001	2-6	6-1. Location of Miscellaneous Parts	6-14
3-1. Plug-in Drawer Installation and Removal	3-2	6-2. Location of Cabinet Parts, 3480C	6-15
3-2. Connecting the Guard	3-3	6-3. Location of Cabinet Parts, 3480D	6-16
3-3. Sample/Hold Measurement of Full Range Step Input	3-5		
3-4. Sample/Hold Analog Output	3-5	7-1. Location of Assemblies	7-2
4-1. Simplified Block Diagram	4-1	7-2. Block Diagram	7-3/7-4
4-2. Successive Approximation Comparison Sequence	4-1	7-3. Schematic Diagram, Polarity Amplifier Assembly A3 or A8; D/A and Comparator Assembly, A4	7-5
4-3. Polarity Indicator Circuit	4-2	7-4. Waveforms	7-6
4-4. Comparator Amplifier	4-3	7-5. Schematic Diagram, Clock and D/A Logic Assembly, A2	7-7/7-8
4-5. Sample Oscillator and Reset Amplifier	4-4	7-6. Schematic Diagram, Decoding and Annunciator Assembly, A6 and A7	7-9/7-10
4-6. Hold and Trigger Circuits	4-4	7-7. Schematic Diagram, Sample Generator Circuits, A1	7-11/7-12
4-7. Clock Circuits	4-5	7-8. Schematic Diagram, Power Supplies, A1 and A6	7-13/7-14
4-8. 18-Pulse Counter	4-5	7-9. Schematic Diagram, Sample/Hold Option 001, A12, A13	7-15/7-16
4-9. Typical Counter Decoding Logic Gate	4-5	7-10. Units Shift Register Input	7-17/7-18
4-10. Clock and Counter Timing Sequence	4-6	7-11. Schematic Diagram, Isolated BCD Output Assembly A11	7-19/7-20
4-11. Typical D/A Memory Logic Circuit	4-7	7-12. Schematic Diagram, Isolated Power Supply Assembly, A9	7-21/7-22
4-12. Series D/A Switch	4-8	7-13. Connector Wiring	7-23/7-24
4-13. Shunt D/A Switches	4-9	7-14. Ground Connections	7-25/7-26
4-14. Logic Waveform Sequence	4-10		
4-15. Comparison Sequence Example	4-11		
4-16. Power Supply Block Diagram	4-11		
4-17. Sample/Hold Timing	4-12		
4-18. Isolated BCD Output Circuit	4-13		
5-1. Location of Adjustments, All Instruments Except Option 001	5-3		
5-2. Suggested Test Fixture Schematic	5-4		
5-3. Location of Adjustments, Option 001 Instruments	5-5		

SECTION I GENERAL INFORMATION

1-1. INTRODUCTION.

1-2. The -hp- Model 3480C or 3480D Digital Voltmeter in combination with one of the plug-in units available makes measurements with four-digit resolution, and up to 50% overrange capability on most ranges and functions. The display includes a fifth digit "1" for overrange measurements. Polarity selection and display are automatic. Most controls, such as range, function, filter and sample rate selection, are contained in the plug-in unit. The following functions and ranges are available in the various plug-in units:

Plug-In Unit	Function and Range
Model 3482A DC Range Unit	DC Volts 100 mV thru 1000 V ranges
Model 3484A Multifunction Unit	DC Volts 100 mV thru 1000 V ranges AC Volts (optional) 1 V thru 1000 V ranges Ohms (optional) 100 Ω thru 10 M Ω ranges
Model 3485A Scanning Unit (10, 20, 30, 40 or 50 channels)	DC Volts 100 mV thru 10 V ranges

1-3. The Model 3480C is a bench model instrument, while the Model 3480D is designed to facilitate rack mounting. The electrical performance of the two models is identical. Throughout this manual, the term 3480C/D will be used when no distinction between instruments is made. Any information that applies to one instrument only will be clearly indicated.

1-4. SPECIFICATIONS.

1-5. Complete specifications for the Model 3480C/D Digital Voltmeter in combination with the various plug-in units are given in Table 1-1.

1-6. OPTIONS.

1-7. Sample/Hold Option 001.

1-8. The Sample/Hold option for the 3480C/D permits accurate scanning of changing input voltage. In addition, the Sample/Hold feature may be used for digitizing

low-frequency waveforms, for peak readings, response time measurements, or transient analysis. Any of the available 3480 series plug-in units may be used in an instrument equipped with this option.

1-9. Isolated BCD Output, Option 004.

1-10. Option 004 provides eight columns of BCD output information, print command signal, a printer hold off line, and positive and negative voltage references. An external input trigger connection is also available through the rear panel BCD output connector. The Option 004 input and output signals are referenced to chassis (power line) ground, which is isolated from the LO input terminal and the 3480C/D circuit common. Option 004 can be installed either at the factory or in the field as an accessory 11187C (see Paragraph 2-30).

1-11. ACCESSORIES SUPPLIED.

1-12. Accessories supplied with the 3480C/D include two printed circuit extender boards, -hp- Part No. 5060-6033, and a rack mount kit (3480D only). A 50-pin mating connector for the BCD output, -hp- Part No. 1251-0086, is supplied with Option 004. A remote control connector for the Sample/Hold option, -hp- Part No. 1251-1757, is supplied with Option 001.

1-13. ACCESSORIES AVAILABLE.

1-14. A Plug-in Extender Cable, -hp- 11148A, is available for servicing plug-in units with the 3480C (not required for 3480D). This cable permits operation of the plug-in unit outside the instrument.

1-15. The -hp- 11146A Interface Kit is available to link the 3480C/D with the -hp- 2114/2115/2116 Computer. The 3480C/D must be equipped with Option 004 Isolated BCD for use with this interface kit. In addition, if remote control of range and function is desired, the plug-in unit must have Isolated Remote Control.

1-16. The -hp- Model 2070A Data Logger combines a Model 3480C (using any of the plug-in units) and a Model 5055A Digital Recorder in one unit for convenient operation and installation.

1-17. INSTRUMENT AND MANUAL IDENTIFICATION.

1-18. Instrument identification by serial number is located on the rear panel. Hewlett-Packard uses a two-section serial number consisting of a four-digit prefix and a five-digit suffix. Some instruments have a letter separating the two sections of the serial number, indicating the country in which the instrument was manufactured.

1-19. No change sheet supplement will be supplied for this manual. Any change information has already been integrated into the manual by page revisions. Revised pages are so

designated in the lower corner of the page. You may obtain subsequent revisions by returning the questionnaire in the front of this manual.

Table 1-1. Specifications.

DC VOLTAGE		Normal-Mode Rejection: (NMR is the ratio of the peak normal-mode signal to the resultant error in reading).		
Range:	3482A and 3484A	3485A	Filter Position	50 Hz and 60 Hz
	100 mV 1000 mV 10 V 100 V 1000 V	100 mV 1000 mV 10 V	3482A and 3484A: Out A B 3485A: Out In	0 dB > 27 dB > 77 dB 0 dB > 27 dB 0 dB > 30 dB
<p>Overrange: 50% on all ranges, ± 1200 V max input (peak), (± 50 V peak for 3485A).</p> <p>Range Selection: manual, automatic or remote.</p> <p>Automatic Ranging: upranges at 140% of range; downranges at 10% of range.</p> <p>Accuracy (90 days, 25°C ± 5°C, < 85% relative humidity):</p> <p>3482A and 3484A: 100 mV range: ± (0.01% of reading + 0.02% of range). All other ranges: ± (0.01% of reading + 0.01% of range).</p> <p>3485A: 100 mV range: ± (0.01% of reading + 0.04% of range). 1000 mV and 10 V ranges: ± (0.01% of reading + 0.01% of range).</p> <p>Sample/Hold Option 001: Delay off: ± 0.03% of range to 100 mV range for any plug-in. Delay on: no specification implied if delay is used on 100 mV range.</p> <p>Temperature Coefficient (0°C to 55°C):</p> <p>3482A, 3484A and 3485A: 100 mV range, Filter Out: ± (0.001% of reading + 0.0005% of range)/°C. 100 mV range, Filter A or B: ± (0.001% of reading + 0.0015% of range)/°C. All other ranges, with or without filter: ± (0.001% of reading + 0.0005% of range)/°C.</p> <p>Input Resistance: 3482A and 3484A: 100 mV, 1000 mV and 10 V ranges: > 10¹⁰ Ω. 10 V and 1000 V ranges: 10 MΩ ± 0.1%.</p> <p>3485A (25°C, < 85% RH): > 10⁷ Ω.</p> <p>Effective Common-Mode Rejection: (ECMR is the ratio of the peak common-mode voltage to the resultant error in reading with 1 kΩ unbalance in either lead). 3482A and 3484A: > 80 dB, dc to 60 Hz. 3485A: DC: > 80 dB. AC (50 - 60 Hz): Filter Out: > 70 dB. Filter In: > 105 dB.</p>		<p>OHMS 3484A only, Option 042</p> <p>Range:</p> <p>100 Ω 1000 Ω 10 kΩ 100 kΩ 1000 kΩ 10 MΩ</p> <p>Overrange: 50% on all ranges. Range Selection: manual, automatic or remote. Automatic Ranging: upranges at 140% of range; downranges at 10% of range. Accuracy (90 days, 25°C ± 5°C, < 85% relative humidity):</p> <p>100 Ω range: ± (0.02% of reading + 0.05% of range). 1000 Ω through 1000 kΩ ranges: ± (0.01% of reading + 0.01% of range). 10 MΩ range: ± (0.1% of reading + 0.01% of range).</p> <p>Temperature Coefficient (0°C to 55°C):</p> <p>100 Ω through 100 kΩ ranges: ± (0.0015% of reading + 0.0005% of range)/°C. 1000 kΩ and 10 MΩ ranges: ± (0.0035% of reading + 0.0005% of range)/°C.</p> <p>TRUE RMS AC VOLTAGE 3484A only, Option 043</p> <p>Range:</p> <p>100 mV 1000 mV 10 V 100 V 1000 V</p> <p>Overrange: 50% on all ranges, 1500 V peak input. Range Selection: manual, automatic or remote.</p> <p>Automatic Ranging: upranges at 140% of range; downranges at 10% of range.</p> <p>Accuracy (90 days, 25°C ± 5°C, < 85% relative humidity): as specified by graphs A through E.</p>		

Table 1-1. Specifications (Cont'd).

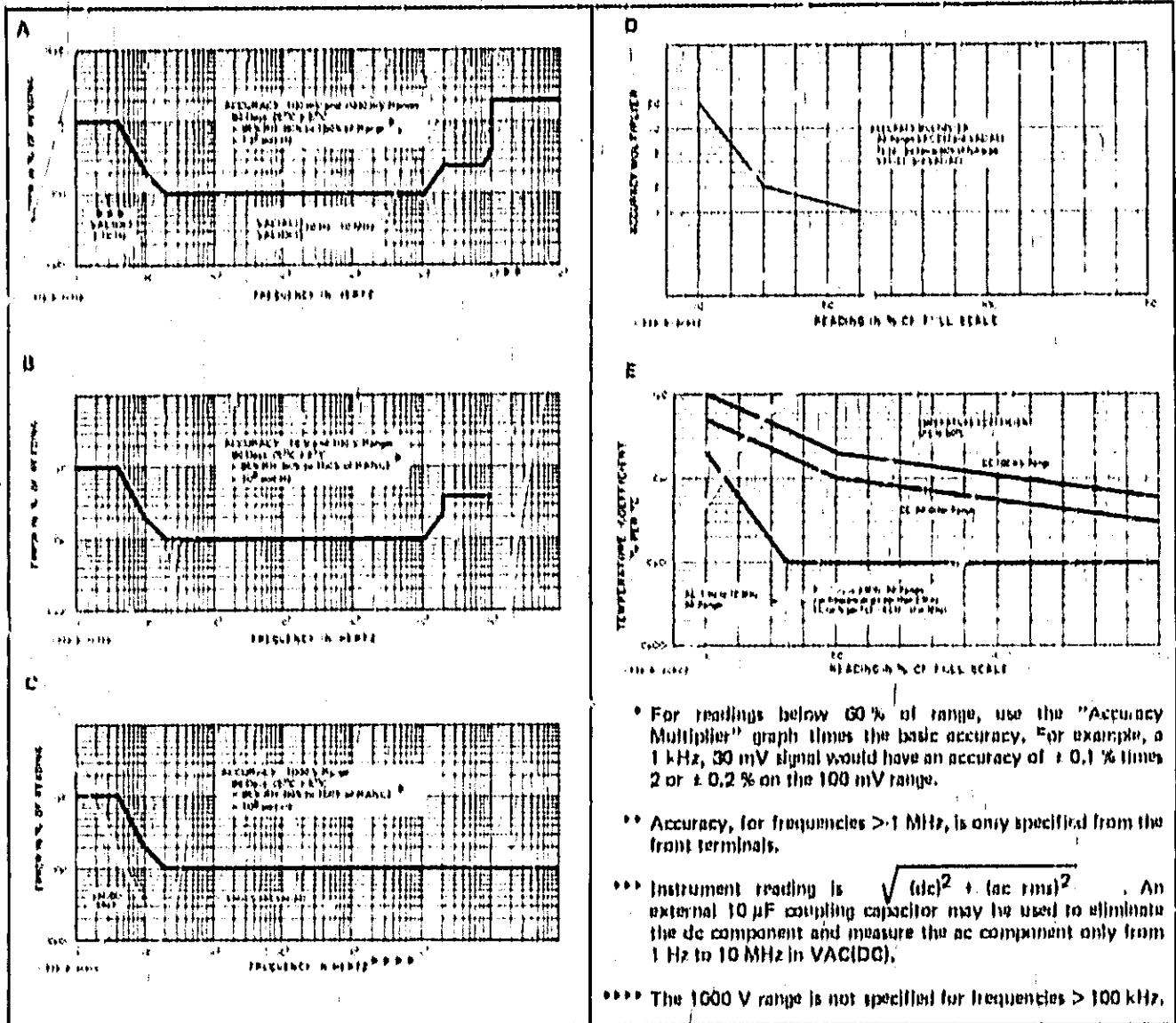

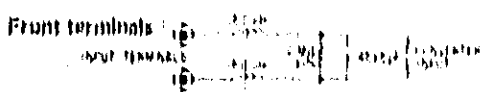

Table 1-2. Typical Operating Characteristics.

DC VOLTAGE	(Internal: 1 to ≥ 25 per second with front panel control. External: 0 to 1000 per second with external trigger.)
Response Time: (Time required to read within 1 count of final reading when triggered coincident with application of a step input voltage.)	3485A scanning and reading rate: Manual: readings may be initiated manually on any one channel with front panel self-latching Monitor pushbutton at a fixed 3 readings per second. Internal: readings may be automatically initiated in the Single Scan or Continuous Scan modes at any one of six Channel Delays. Speed ranges from 1 channel per second to 1000 channels per second. With Filter In, a minimum delay of 250 ms is used. External: 0 to 1000 channels per second with external trigger.
3482A and 3484A: Filter Out: 1 ms. Filter A: 200 ms. Filter B: 1 s.	3485A Channel Delay: Six delays; 1 s, 500 ms, 250 ms, 125 ms, 62 ms and None. The reading is taken after the selected Channel Delay. In None, the speed is limited mainly by the reading period (1 ms).
3485A: Filter Out: 1 ms. Filter In: 250 ms.	
Filter Selection: manual or remote.	
Reading Period: 0.50 μ s.	
Reading Rate (without range change):	
3482A and 3484A: Manual: reading may be initiated manually with front panel pushbutton.	

Table 1-2. Typical Operating Characteristics (Cont'd).

<p>Maximum Input Voltages: 3482A and 3484A: Between High and Low terminals: ± 1200 V peak, Between Low and Guard terminals: ± 200 V peak, Between Guard and Chassis: ± 500 V peak.</p> <p>3485A: High to Low: ± 50 V peak, Low to Guard: ± 50 V peak, Guard to Chassis: ± 50 V peak.</p> <p>Maximum Step Change in Input Voltage: (Exceeding these limits can result in error, false triggering, and an incorrect flag.)</p> <p>3482A and 3484A Between HIGH and LO terminals: < 300 V peak Between LO and GUARD terminals: < 20 V peak Between GUARD and chassis: < 100 V peak</p> <p>Maximum 3485A Operating Voltage (for rated accuracy): High to Low: ± 15 V dc, Low to Guard: ± 10 V peak, Guard to Chassis: ± 50 V peak.</p> <p>The algebraic sum of all voltages in a path between any Low and any High must not exceed ± 15 V peak, The maximum algebraic voltage difference between any Low and any other Low must not exceed ± 15 V peak.</p> <p>Zero Offset (3482A and 3484A): Voltage stability (at constant temperature): < 10 μV/week, Voltage temperature coefficient (0° C to 55° C): $< \pm 1$ μV/$^\circ$ C, Current (25° C $\pm 5^\circ$ C): $< \pm 10$ pA, Current temperature coefficient (0° C to 55° C): $< \pm 1$ pA/$^\circ$ C.</p> <p>Noise: < 40 μV peak to peak (unfiltered). Peak to peak noise is less than 40 μV 85% of the time since the noise amplitude approximates a Gaussian distribution where the standard deviation (which is also the rms value) = 10 μV.</p> <p style="text-align: center;">OHMS 3484A Option 042</p> <p>Response Time: (Time required to read within 1 count of final reading when triggered coincident with application of input.) 100 Ω through 100 kΩ ranges (no filtering): 1 ms. 1000 kΩ range (Filter A): 200 ms. 10 MΩ range (Filter A): 2 s.</p> <p>NOTE: Due to noise generated in the unknown resistance, filtering may be required for quiet readings with inputs > 100 kΩ. Response times with filtering are proportionally less than those shown for inputs below full scale.</p> <p>Reading Period: 850 μs.</p> <p>Reading Rate (without range change): Manual: reading may be initiated manually with front panel pushbutton.</p>	<p>Internal: 1 to ≥ 25 per second with front panel control. External: 0 to 1000 per second with external trigger.</p> <p>Autorange Time per Range Change: Filter Out: 4 ms, Filter A: 200 ms, Filter B: 1 s.</p> <p>Voltage across Unknown Input: 1 V at full scale, all ranges.</p> <p>Current through Unknown Input: 100 Ω range: 10 mA, 1000 Ω range: 1 mA, 10 kΩ range: 100 μA, 100 kΩ range: 10 μA, 1000 kΩ range: 1 μA, 10 MΩ range: 100 nA.</p> <p>Overload Protection: ± 75 V peak maximum input, all ranges.</p> <p style="text-align: center;">TRUE RMS AC VOLTAGE 3484A Option 043</p> <p>Response: VAC(AC) function: responds to true rms value of ac coupled input signal. VAC(DC) function: responds to true rms value of dc and ac input signal. Reading is $\sqrt{(dc)^2 + (ac rms)^2}$. An external 10 μF coupling capacitor may be used to eliminate the dc component and measure ac component only from 1 Hz to 10 MHz.</p> <p>Function selection: manual or remote.</p> <p>Response Time (without range change): VAC(AC): 1 second to within 10 counts of final reading (input change from 10% to 100% of range) or 20 counts of final reading (input change from 100% to 10% of range). VAC(DC): 15 seconds to within 10 counts of final reading.</p> <p>Reading Rate: Manual: reading may be initiated manually with front panel pushbutton. Internal: 1 to ≥ 25 per second with front panel control. External: 0 to 1000 per second with external trigger.</p> <p>Autorange Time per Range Change: VAC(AC): 1 second. VAC(DC): 3 seconds.</p>
---	--

Table 1-2. Typical Operating Characteristics (Cont'd).

<p>Input Impedance:</p> <p>Front terminals: </p> <p>Rear terminals: </p> <p>Crest Factor: 7:1 at full scale, derated linearly from 35 Hz to 2.2:1 at 5 Hz.</p> <p>Maximum Input Voltage:</p> <p>VAC(AC): 1500 V peak ac, 100 V dc (10 V dc max on 100 mV range); dc + ac = 1500 V max.</p> <p>VAC(DC): 1000 V rms; dc + ac = 1500 V max</p> <p style="text-align: center;">SAMPLE/HOLD 3480C/D Option 001</p> <p>Acquisition Time: (Time to respond to a plus or minus full-range step input to within ± 0.01 % of final value.)</p> <table border="1" data-bbox="338 963 772 1145"> <thead> <tr> <th>Range</th> <th>3482A, 3484A</th> <th>3485A</th> </tr> </thead> <tbody> <tr> <td>100 mV</td> <td>100 μs</td> <td>100 μs</td> </tr> <tr> <td>1000 mV</td> <td>70 μs</td> <td>70 μs</td> </tr> <tr> <td>10 V</td> <td>70 μs</td> <td>60 μs</td> </tr> <tr> <td>100 V</td> <td>70 μs</td> <td></td> </tr> <tr> <td>1000 V</td> <td>70 μs</td> <td></td> </tr> </tbody> </table> <p>Maximum ΔV/ΔT: 8 % of range per μs, Sample/Hold enabled.</p>	Range	3482A, 3484A	3485A	100 mV	100 μs	100 μs	1000 mV	70 μs	70 μs	10 V	70 μs	60 μs	100 V	70 μs		1000 V	70 μs		<p>Aperture Time: (Time from command to the Sample/Hold option to take a reading to when the signal is actually held.)</p> <p>100 ns ± 20 ns.</p> <p>NOTE: A delay of 105 μs ± 20 μs may be added to aperture time by using Delay On or by triggering through External Trigger (normal trigger).</p> <p>Modes of Operation: (Selected manually on rear panel, or remotely.)</p> <p>Sample-and-Hold: On: Sample/Hold enabled, Off: Normal 3480 operation, Remote, Remote control.</p> <p>Delay: On: 105 μs delay added before Hold, Off: No delay, Remote: Remote control of delay.</p> <p>Measuring Speeds: Same as DC voltage measuring speed.</p> <p>Analog Output: Sample/Hold output for use with an oscilloscope for the measurement and display of repetitive waveforms. Output is 1 V ± 2 % for full-range input; source resistance 1 kΩ ± 2 %.</p> <p style="text-align: center;">GENERAL</p> <p>Power: 115 V or 230 V ± 10 %, 40 Hz to 440 Hz, 60 VA max including any plug-in or options.</p> <p>Operating Temperature: 0 °C to 65 °C.</p> <p>Storage Temperature: -40 °C to +75 °C.</p>
Range	3482A, 3484A	3485A																	
100 mV	100 μs	100 μs																	
1000 mV	70 μs	70 μs																	
10 V	70 μs	60 μs																	
100 V	70 μs																		
1000 V	70 μs																		

INSTALLATION

SECTION II

INSTALLATION and INTERFACING

2-1. INTRODUCTION.

2-2. This section contains instructions for installing the Model 3480C/D and for interfacing with peripheral equipment. Also included are instructions for repackaging and shipping.

2-3. INITIAL INSPECTION.

2-4. This instrument was carefully inspected both mechanically and electrically before shipment. It should be free from marks and scratches and in perfect electrical order. The instrument should be inspected upon receipt for damage that might have occurred in transit. If there is damage due to shipping, notify the carrier. The electrical performance should be tested using the procedure outlined in Section V of the Operating and Service Manual. If there is electrical deficiency, refer to the Warranty in the front of the manual.

2-5. POWER REQUIREMENTS.

2-6. The Model 3480C/D can be operated from any source of 115 V or 230 V ($\pm 10\%$) at 48 to 440 Hz. Power dissipation is a maximum of 60 VA, depending upon the plug-in options included.

2-7. POWER CORDS AND RECEPTACLES.

2-8. Figure 2-1 illustrates the standard power receptacle (wall outlet) configurations that are used throughout the United States and in other countries. The -hp- part number shown directly above each receptacle drawing is the part number for a 3480C/D power cord equipped with the appropriate mating plug for that receptacle. If the appropriate power cord is not included with the instrument, notify the nearest -hp- Sales and Service Office and a replacement cord will be provided.

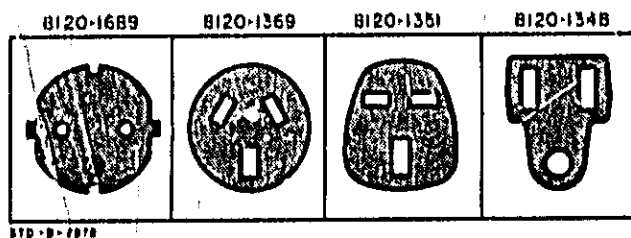

Figure 2-1. Power Cord Receptacles.

2-9. GROUNDING REQUIREMENTS.

2-10. To protect operating personnel, the National Electrical Manufacturers' Association (NEMA) recommends

that the instrument panel and cabinet be grounded. The offset pin of the power cable grounds the instrument when connected to an appropriate three-contact receptacle. If only a two-contact receptacle is available, use a three-contact to two-contact adapter and connect the green wire on the adapter to power line (earth) ground.

2-11. INSTALLATION.

2-12. The Model 3480C/D is fully transistorized, therefore, no special cooling equipment is required. However, the instrument should not be mounted in a manner that would obstruct the free flow of air through the perforated covers. It should not be operated where the ambient temperature exceeds 55^o C (131^o F) or the relative humidity exceeds 95 %. Power dissipation is 60 VA maximum.

2-13. Bench Use.

2-14. The Model 3480C is shipped with plastic feet and tilt stand in place, ready for use as a bench instrument. The Model 3480D is also equipped with plastic feet and tilt stand and may be used as a bench instrument.

2-15. Rack Mounting.

2-15. The Model 3480D may be rack mounted by using the 3" rack mount kit supplied with the instrument. Instructions are included with the kit. The rack mount for the 3480D is an EIA standard width of 19 inches. When mounted in a rack using the rack mount kit, additional support should be provided at the rear of the instrument. For additional information, address inquiries to your nearest -hp- Sales and Service Office.

2-17. INTERFACE CONNECTIONS.

2-18. Sample/Hold Option 001.

2-19. Figure 2-2 shows the connections and logic levels for interfacing the Sample/Hold lines. The mating connector for Sample/Hold is -hp- Part No. 1251-1757 (Amphenol 126-220).

2-20. Isolated BCD Output Option 004.

2-21. Input and Output connections for Option 004 are shown in Figure 2-3. This figure also lists the logic levels and signal requirements for Option 004. The Option 004 input and output signals are referenced to chassis (power line) ground, which is isolated from the LO input terminal and the 3480C/D circuit common. A straight through

output cable, -hp- 562-16C, is available for connecting the BCD output to a digital recorder such as the -hp- Model 5055A. The mating connector for the 3480 C/D BCD output connector is -hp- part number 1251-0086 (Amphenol 57-30500-375).

2-22. Remote Control.

2-23. Remote control is a feature of the individual plug-in unit, and interface information will be found in the appropriate plug-in unit manual.

2-24. INSTALLATION OF OPTIONS.

2-25. Certain options for the 3480C/D may be purchased separately and installed at some time after receipt of the instrument. The following paragraphs outline installation procedures for these options.

2-26. Option 001, Sample/Hold.

2-27. The Option 001 may be purchased separately and installed in any existing 3480C or 3480D. This Field Installation Kit is -hp- 11186A for the 3480C and 11186B for the 3480D. Use the procedure in Paragraph 2-28 for installation in a Model 3480C and Paragraph 2-29 for the 3480D.

2-28. S/H Installation, 3480C.

a. Remove 3480C top and bottom covers. Remove plug-in drawer. If instrument has the Isolated BCD Option 004, proceed to step h. If not, continue with step b.

b. Remove all plug-in printed circuit boards.

c. Loosen printed circuit board support shield (supports rear of printed circuit boards) so that it can be moved away from rear panel to permit access to the bracket attached to the rear panel.

d. Remove bracket from rear panel.

e. Locate two unattached violet wires from power transformer in wire bundle below bracket location. Cut cable tie if necessary and withdraw ends of wires from bundle. Keep wires twisted together.

f. Connect the two violet wires to pins on bottom side of the A9 assembly supplied (Part No. 03480-66509).

g. Attach A9 assembly to rear panel in place of bracket removed in step d. Replace and secure printed circuit board support bracket.

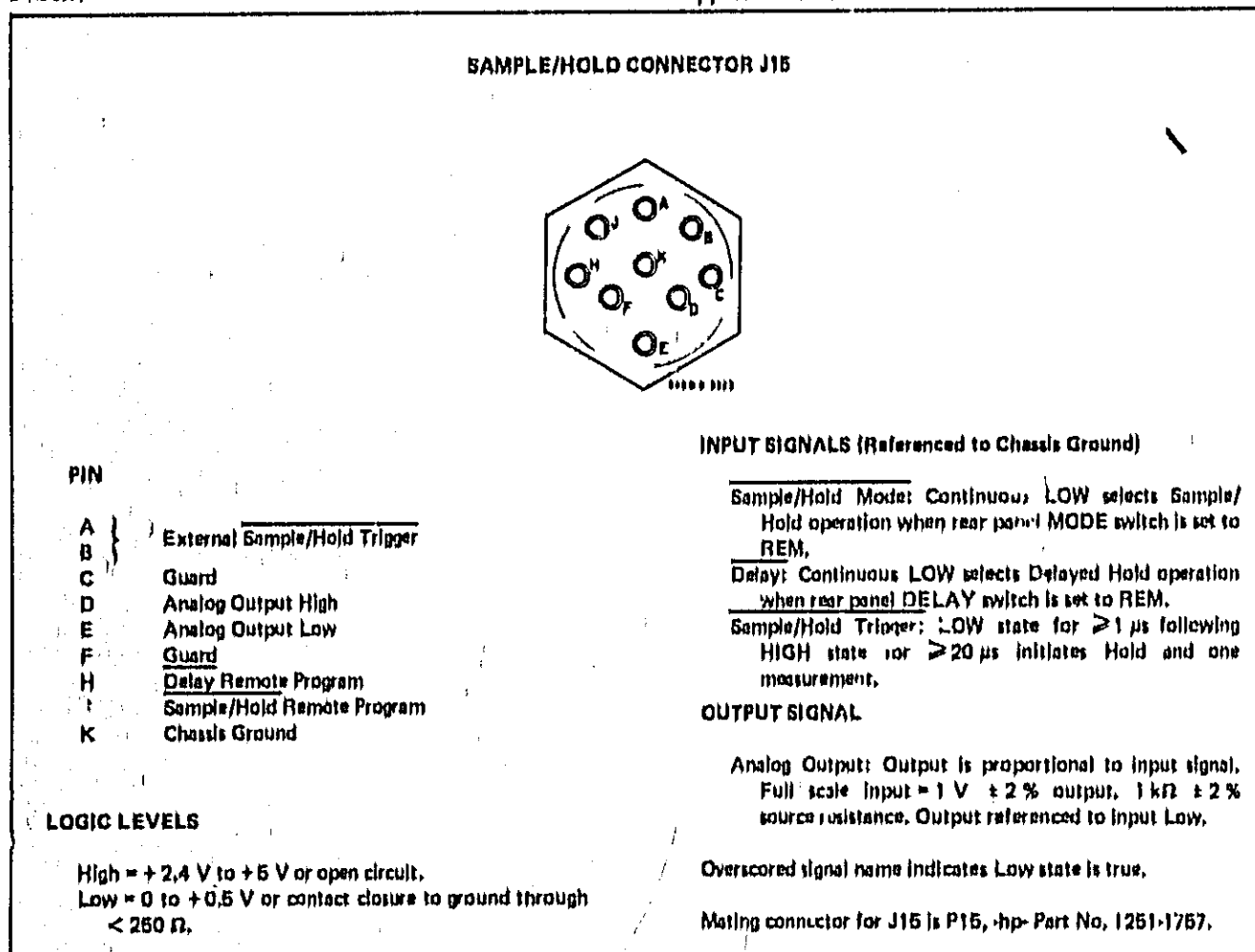

Figure 2-2. Sample/Hold Connections.

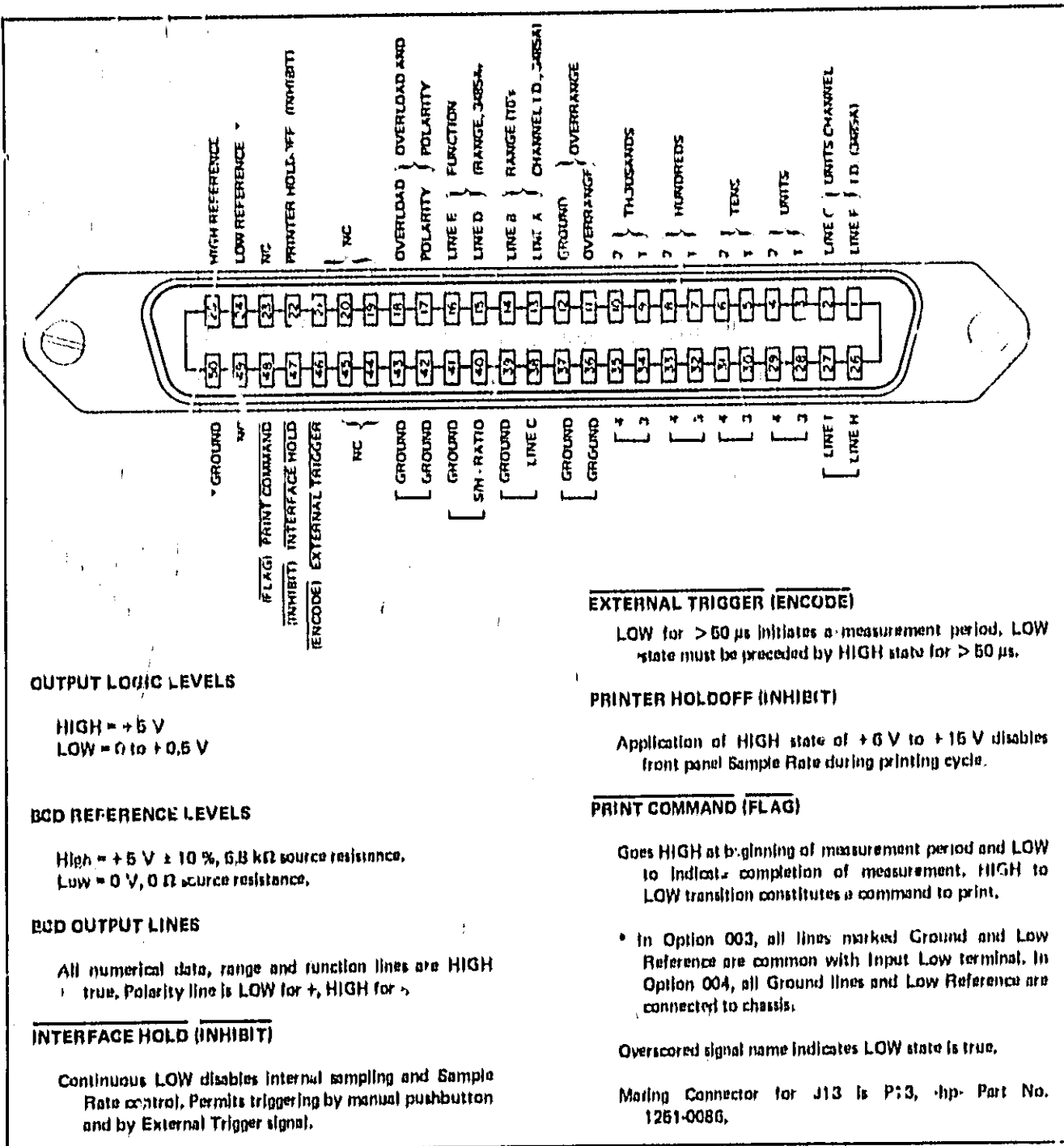

Figure 2-3. BCD Connections, J13.

Table 2-1. Format for Option 004.

Plug-In Unit	10	9	8	7	6	Column				
						5	4	3	2	1
3482A or 3404A		Polarity and Overload	Function	Range	Data Overrange	Data Thousands	Data Hundreds	Data Tens	Data Units	...
3485A		Polarity and Overload	Range	Scanner Channel Tens	Data Overrange	Data Thousands	Data Hundreds	Data Tens	Data Units	Storage Channel Units

h. Remove the dummy panel (angle channel) along bottom edge of rear panel.

i. Remove screw at each side of upper rear panel. Slide entire Master Board assembly toward rear of the instrument so that it extends about 5 inches beyond frame.

j. Locate bundle of short wires attached to rear panel by cable clamp. Detach cable clamp from rear panel and cut from wire bundle.

k. Cut off excess sleeving that protrudes beyond ends of connectors on these wires.

l. Mount A12 Sample/Hold Interface Assembly (Part No. 11186-66502) to rear panel with wires underneath the assembly. The transformer, T1, should be at lower edge. Make sure wires are not pinched between spacers and rear panel.

m. Insert rubber grommet (on wires from rear panel S/H connector) in slot at bottom of rear panel. Run black cable below plug-in connector and along large wire bundle into printed circuit compartment (upper section of 3480C).

n. Tie black cable (and white/green wire if used) to large wire bundle near end of plug-in connector.

o. Connect wires (step h) to A12 assembly as indicated in Figure 2-4.

p. Slide Master Board assembly into instrument and secure upper and lower rear panel sections to frame. Make sure no wires are pinched between rear panel and frame.

q. If Option 004 was not previously installed, locate unattached black wire and white wire in wire bundle along side of printed circuit compartment. Cut cable tie if necessary and withdraw ends of these wires. Connect to pins on A9 assembly as indicated in Figure 2-8.

r. If printed circuit boards were removed in step b, replace all boards except A3 Polarity Amplifier Assembly (03480-66503).

s. Route black cable from S/H circuits under A4 assembly (and any board installed in J5A, B) next to rear of printed circuit connector. Connect black wire to TP7 and white wire to TP6 on the Sample/Hold Analog Assembly (Part No. 11186-66501).

t. Insert Sample/Hold Analog Assembly in J3 (position formerly occupied by A3).

u. Replace 3480C top and bottom covers.

2-29. S/H Installation, 3480D.

a. Remove 3480D top and bottom covers. Remove plug-in drawer. If instrument has the Isolated BCD Option 004, proceed to step f. If not, continue with step b.

2-4. Rev. A

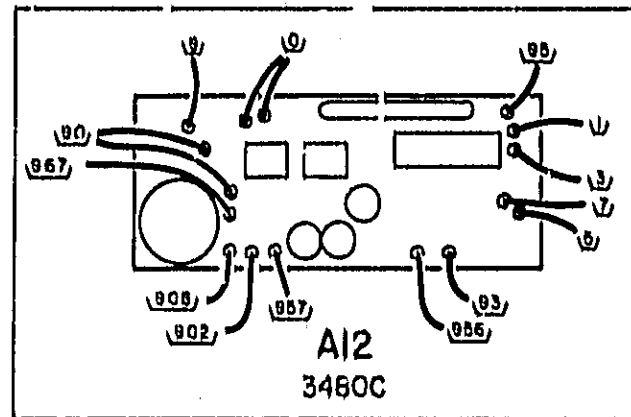

Figure 2-4. Sample/Hold Board Connections, 3480C.

b. Remove bracket from inside rear panel next to power transformer.

c. Locate two unattached violet wires from power transformer in wire bundle below bracket location. Cut cable tie if necessary and withdraw ends of wires from bundle. Keep wires twisted together.

d. Connect the two violet wires to pins on bottom side of the A9 assembly supplied (Part No. 03490-66509).

e. Attach A9 assembly to rear panel in place of bracket removed in step b.

f. Remove cover plate near center of rear panel.

g. Locate several unattached wires in bundle near plug-in connector. Cut cable ties as necessary to release these wires. Cut off excess sleeving that protrudes beyond ends of connectors on these wires.

h. Mount A12 Sample/Hold Interface Assembly in rear panel opening. This is printed circuit board Part No. 11186-66503 attached to a metal plate along with Sample/Hold connector.

i. Connect wires located in step g to pins on A12 assembly as indicated in Figure 2-5.

j. Route black cable along large wire bundle into printed circuit board compartment of 3480D.

k. Remove A3, Polarity Amplifier Assembly.

l. Route black Sample/Hold cable under A4 (and any board installed in J5A, B) next to rear of printed circuit connector. Connect black wire to TP7 and white wire to TP6 on the Sample/Hold Analog Assembly (Part No. 11186-66501).

m. Insert Sample/Hold Analog Assembly in J3 (position formerly occupied by A3).

n. Replace 3480D top and bottom covers.

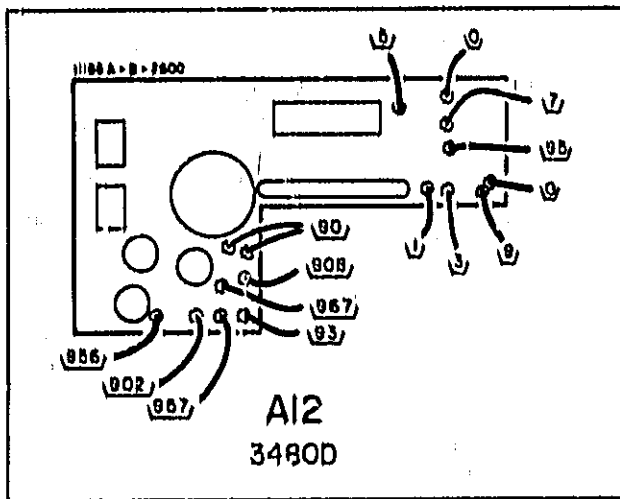

Figure 2-5. Sample/Hold Board Connections, 3480D.

2-30. Option 004, Isolated BCD Output.

2-31. The Isolated BCD Output Assembly, Option 004, may be purchased as an accessory number 11187C and installed in existing instruments.

a. Remove 3480C/D top and bottom covers. If the instrument is Model 3480D, proceed to step d. If it is Model 3480C, continue with step b.

b. Remove all plug-in printed circuit boards and remove plug-in drawer.

c. Loosen printed circuit board support shield (supports rear of printed circuit boards) so that it can be moved away from rear panel to permit access to the bracket attached to rear panel.

d. Remove bracket from inside rear panel.

e. Locate two unattached blue wires from power transformer in wire bundle below bracket location. Cut cable tie if necessary and withdraw ends of wires from bundle. Keep wires twisted together.

f. Connect two blue wires to pins on bottom side of the new A9 assembly supplied (Part No. 03480-66509).

g. Attach A9 assembly to rear panel in place of bracket removed in step d.

h. Locate unattached black wire and white wire in bundle along side of printed circuit compartment. Withdraw ends of these wires from bundle and connect to pins c and b on top side of A9 as shown in Figure 2-7.

i. Replace board support shield loosened in step c and replace printed circuit boards (3480C).

j. Connect power cord and turn 3480C/D on. Check for +5 V \pm 5% at point indicated in Figure 2-7. Ground for this supply is chassis ground. If voltage is correct, turn power off and disconnect power cord. If not, troubleshoot A9 assembly and input from power transformer.

k. Remove filter plate from rear panel. Insert BCD connector through rear panel opening and secure to outside of rear panel.

l. Install A11 BCD Assembly in J5A and J5B. Connect single white wire (guard) from cable to pin on master board (A6) near end of board support shield.

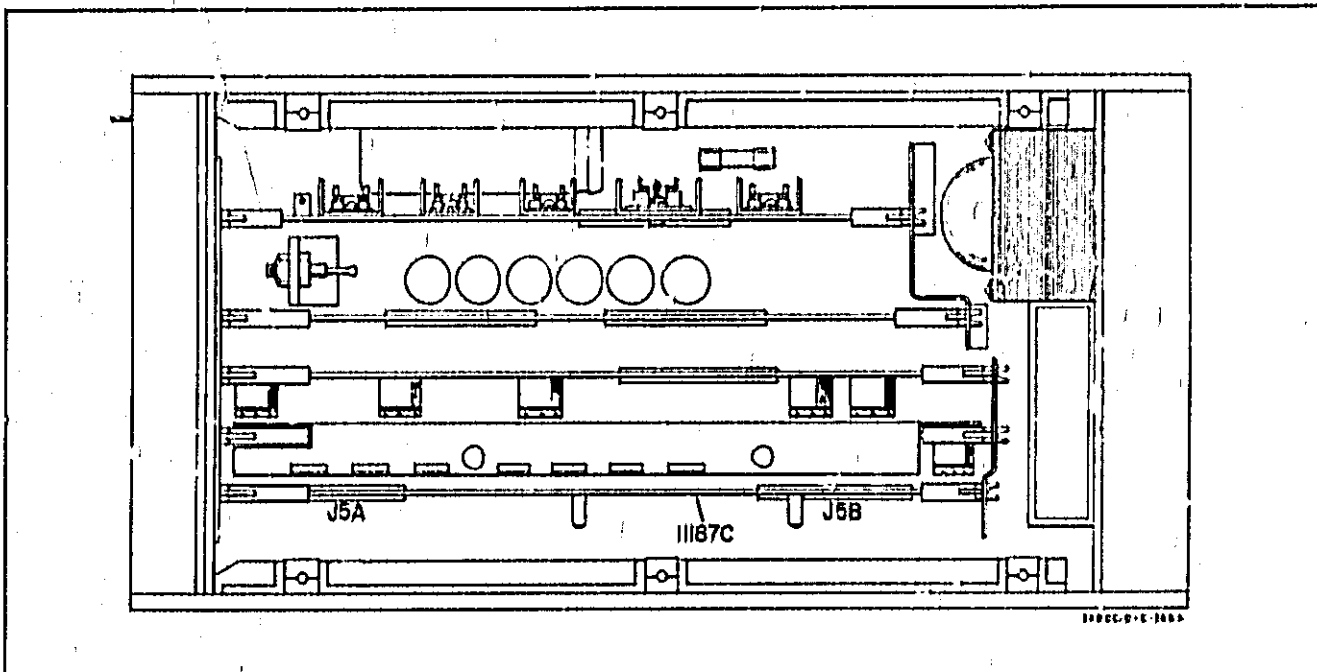

Figure 2-6. Location of BCD Output Assembly.

m. Connect black (ground) and red (+5 V) wires from cable to A9 pins D and E as indicated in Figure 2-7.

n. Replace 3480C/D top and bottom covers. Affix Option 004 label to rear panel.

o. Check performance of the Isolated BCD Output circuits using the procedure given in Paragraph 5-7.

2-32. REPACKAGING AND SHIPMENT.

2-33. The following paragraphs contain a general guide for repackaging the instrument for shipment. Refer to Paragraph 2-34 if the original container is to be used; 2-35 if it is not. If you have any questions, contact your nearest hp-Sales and Service Office.

NOTE:

If the instrument is to be shipped to Hewlett-Packard for service or repair, attach a tag to the instrument identifying the owner and indicating the service or repair to be accomplished. Include the model number and full serial number of the instrument. In any correspondence, identify the instrument by model number and full serial number.

2-34. Place instrument in original container with appropriate packing material and seal well with strong tape or metal bands. If original container is not available, one can be purchased from your nearest hp-Sales and Service Office.

CAUTION

DO NOT SHIP 3480C/D WITH PLUG-IN UNIT INSTALLED OR DAMAGE MAY OCCUR DURING SHIPMENT.

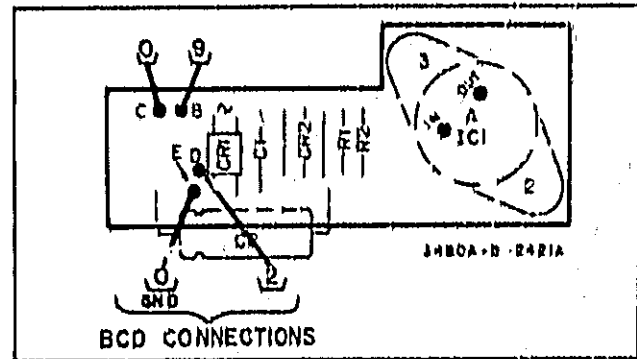

Figure 2-7. A9 Installation for BCD Option 004.

2-35. If original container is not to be used, proceed as follows:

- Wrap instrument in heavy paper or plastic before placing in an inner container.
- Place packing material around all sides of instrument and protect panel face with cardboard strips.
- Place instrument and inner container in a heavy carton and seal with strong tape or metal bands.
- Mark shipping container "DELICATE INSTRUMENT", "FRAGILE", etc.

OPERATION

SECTION III OPERATING INSTRUCTIONS

3-1. INTRODUCTION.

3-2. The Model 3480C/D Digital Voltmeter, in combination with one of the plug-in units available makes dc voltage, ac voltage, or resistance measurements with 4-digit resolution and up to 50% overrange capability on all except the 1000 V ranges. Measurement function and range depend upon the capability of the particular plug-in unit selected. Refer to the plug-in Operating and Service Manual for specific operating instructions. Polarity selection and display are automatic for dc voltage measurements. The following paragraphs give general operating conditions and requirements for the Model 3480C/D, including available options.

3-3. PLUG-IN UNIT INSTALLATION.

3-4. Figure 3-1 illustrates the proper method of inserting and removing the plug-in drawer. The latch is a convenient handle for removing the drawer, but should not be used as a carrying handle. The Model 3480C/D will not operate without a plug-in unit.

3-5. GENERAL OPERATING CONDITIONS.

3-6. Turn-on and Warm-up.

3-7. Make sure the rear panel 115/230 switch is set to the correct line voltage before connecting the 3480C/D power cord. Turn the line switch on and allow the instrument to warm up for at least one hour.

3-8. Maximum Input Voltage.

3-9.



INPUT VOLTAGES MUST NOT EXCEED THE FOLLOWING MAXIMUM VOLTAGES, OR DAMAGE TO THE INSTRUMENT MAY RESULT:

3482A OR 3484A:

1200 V PEAK BETWEEN HIGH AND LOW INPUT TERMINALS.

200 V PEAK BETWEEN LOW AND GUARD TERMINALS.

500 V PEAK BETWEEN GUARD TERMINAL AND CHASSIS.

3485A:

50 V PEAK BETWEEN HIGH AND LOW INPUT TERMINALS.

50 V PEAK BETWEEN LOW AND GUARD TERMINALS.

50 V PEAK BETWEEN GUARD TERMINAL AND CHASSIS.

3-10. Maximum Step Change in Input Voltage.

3-11. When the 3482A and 3484A are used to take readings from changing voltage sources, consideration must be given to the internal capacitance. As the input voltage is changed, the HIGH to LO, LO to GUARD, and GUARD to Chassis capacitance is charged or discharged to a new voltage level. A surge current will occur at the instant the voltage is applied. This surge current flows inside the instrument and can cause errors, false triggering, and an incorrect flag. The amount of surge current is dependent on the change between the previously applied voltage and the newly applied voltage. A 56 Ω 2 watt metal oxide resistor (hp Part Number 0784-0013) placed near the voltage source and in series with the HIGH input terminal will increase the allowable change between the HIGH and LO terminal from 300 V peak to 900 V peak.

NOTE

The use of a resistor in the LO or GUARD lead will effect the Common-Mode rejection.

3-12. **Common-Mode Voltages.** Common-mode voltages are those existing between the power line ground point of the source circuitry and that of the 3480C/D, and between the Low measurement point and power line ground of the source circuit. When current due to these voltages flows into the 3480C/D input terminals, some error in measurement results, because of the voltage drop in the measuring circuit. In systems measurements, the resistance of long input leads may become significant. Wide separation between the 3480C/D power line ground point and the ground point of the source circuit may result in high common-mode voltage.

3-13. **Guard Connection.** Figure 3-2 illustrates three ways of connecting the 3480C/D guard terminal to reduce errors caused by common-mode voltages. In example A, Guard is at practically the same potential as the Low measurement point, so any common-mode current flows through Guard and not through the measurement circuit. In example B, the 3480C/D Guard is connected to the Low terminal,

placing both at the same potential. This allows common-mode current to flow through the input lead resistance R_{in} , causing some measurement error. This connection may be used if common-mode voltages are not expected to be a problem. Example C is similar to A, except that connecting Guard in this manner allows any common-mode current generated between the Low measurement point and power line ground of the source circuit to flow in the measurement circuit. Guard should always be connected, either to the Low terminal or to a point in the source circuit as indicated. If the guard terminal is left open, common-mode

voltages may exceed the Low-to-Guard breakdown rating and damage the 3480C/D.

3-14. Guarding Information. More detailed information on purpose and methods of guarding may be found in Ship Application Note No. 123, "Floating Measurements and Guarding". This application note is available through your nearest Ship Sales and Service Office.

3-15. Floating Measurements.

3-16. The Model 3480C/D is capable of making floating measurements. That is, the input Low terminal is not

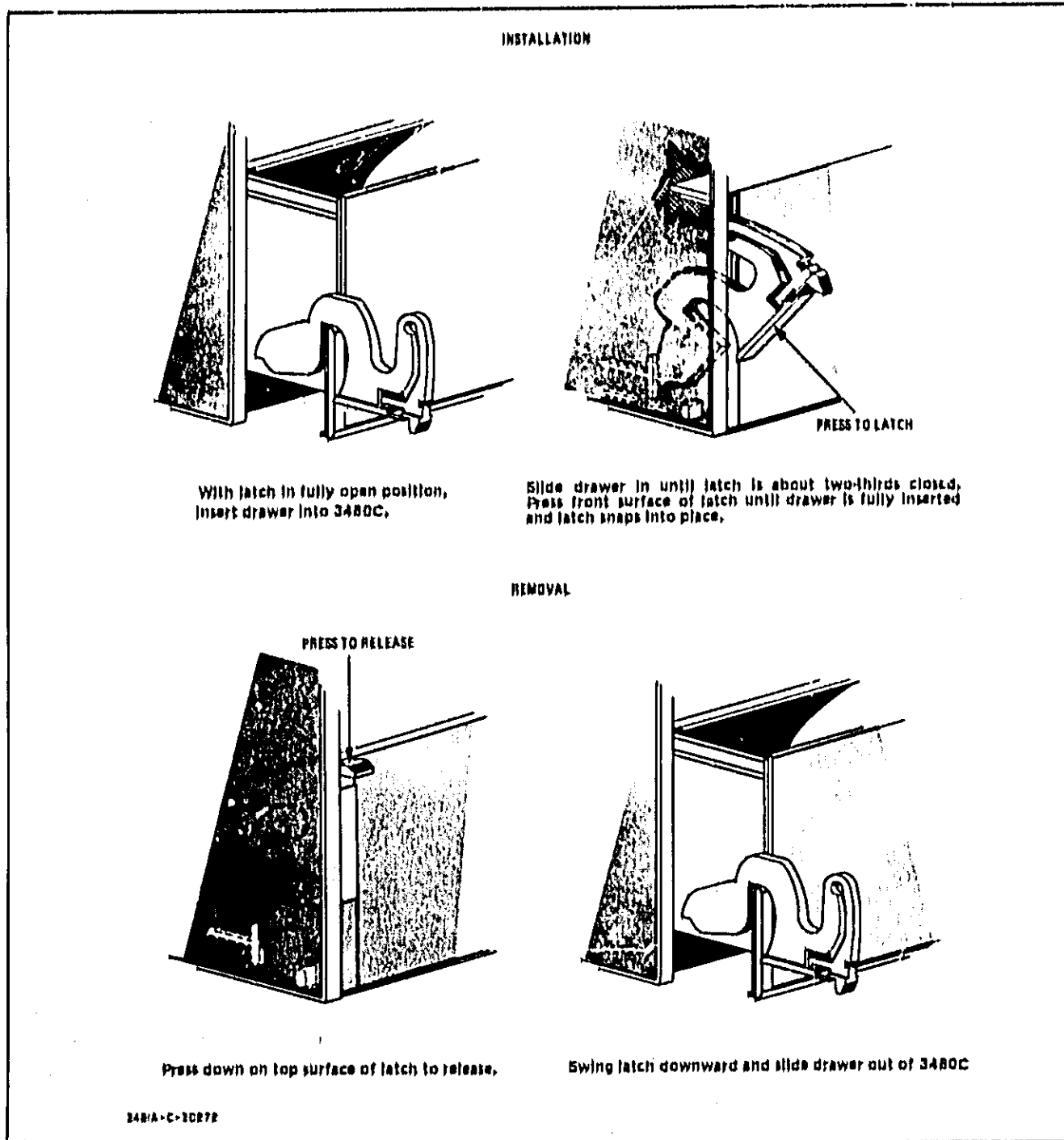

Figure 3-1. Plug-In Drawer Installation and Removal.

connected to chassis (power line) ground. The voltage between the guard terminal and chassis must not be greater than 500 V peak (50 V peak for 3485A). Floating measurements cannot be made with BCD Output Option 003 unless the printer or other connecting equipment can be floated.

3-17. Overrange Measurements.

3-18. Measurements within rated accuracy are possible up to 150 % of range on all except the 1000 V ac or dc ranges. Overage inputs on these ranges would exceed the maximum allowable input voltage. The display includes the overrange "1" as the fifth digit.

3-19. Overload Indication.

3-20. If the measurement is greater than 14999 on any range, the OVERLOAD indicator will be on, and the reading will not necessarily be correct.

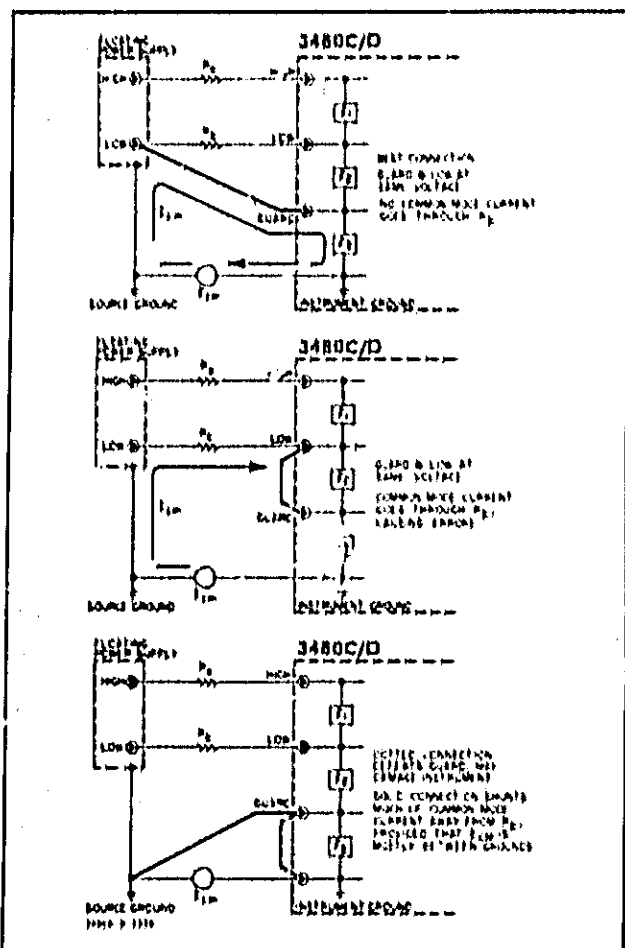

Figure 3-2. Connecting the Guard.

3-21. Sample Control (3482A, 3484A).

3-22. Automatic Sampling. The automatic sampling rate is variable from one sample per second to at least 25 samples per second by means of the SAMPLE RATE control on the front of the plug-in unit.

3-23. Manual Sample Control. When the SAMPLE RATE control is set to HOLD or the Interface Hold connection is grounded, a measurement may be initiated manually by pressing and releasing the TRIG pushbutton on the front of the plug-in unit.

3-24. Remote Triggering. When the SAMPLE RATE control is set to HOLD or the Interface Hold connection is grounded, the instrument may be triggered at rates up to 1000 per second by an external triggering circuit. Interface Hold and External Trigger input connections may be made through the Remote Input connector, or through the Output connector if the 3480C/D has Option 004. The optimum sample rate for a given measurement situation depends upon the function and degree of filtering selected. Refer to the Operating and Service Manual of the plug-in unit in use to determine optimum remote triggering rate. For Sample/Hold measurements, refer to Paragraph 2-23.

3-25. SAMPLE/HOLD OPERATION (Option 001).

3-26. Sample/Hold Interface Signals.

3-27. Sample/Hold interface signal connections and requirements are shown in Figure 2-2.

3-28. Sample/Hold Selection.

3-29. Selection of Sample/Hold and Delay may be made by means of the rear panel MODE and DELAY switches, or by remote programming through the rear panel Sample/Hold connector when the switches are set to REM. A continuous LOW connection is required to program. Table 3-1 lists the various modes of Sample/Hold operation.

3-30. Sample/Hold Off.

3-31. Operation with Sample/Hold OFF is identical to standard Model 3480C/D operation. An external trigger signal may be applied through either pin A or B of the Sample/Hold connector, or through the BCD or plug-in Remote connectors. Sample/Hold external trigger signal requirements are given in Figure 2-2.

3-32. Sample/Hold On, Delay Off, External S/H Trigger.

NOTE

When operating the instrument with Sample/Hold ON, the front panel SAMPLE RATE control must be fully counter-clockwise to the HOLD position, and FILTER must be OUT.

3-33. In this mode of operation, the aperture time (see Paragraph 3-38) between application of an external Sample/Hold trigger command and the resulting Hold command is 110 ns ± 20 ns. Therefore, a trigger command may not be applied simultaneously with a large step input voltage. (Do not use Ext. Trig. or delay results.) Maximum ΔV/ΔT for tracking is 8% of range per microsecond. Maximum

Table 3-1. Modes of Sample/Hold Operation.

Mode of Operation	Trigger Source	External Trigger Input Connection	Trigger Rate	
			3482/4A	3485A
Sample/Hold OFF	Internal		Up to 40/s	Six selectable rates from 1 chan/s to 1000 chan/s
	External	Remote, BCD, or Sample/Hold Connector	Up to 1000/s	Up to 1000 chan/s
Sample/Hold ON Delay OFF	External	Sample/Hold Connector	Up to 1000/s	Usage not recommended.
Sample/Hold ON Delay ON	Internal		Up to 40/s	Six selectable rates from 1 chan/s to 1000 chan/s
	External	Remote, BCD, or Sample/Hold Connector	Up to 1000/s	Up to 1000/s

response time to within 0.01 % of final reading for a full-range step input voltage of either polarity is given in Table 3-3. Minimum input amplifier bandwidth is shown in Table 3-2. External Sample/Hold Trigger signal requirements are in Figure 2-2.

Table 3-2. Minimum Bandwidth.

Range	3482A	3484A
100 mV	15 kHz	12 kHz
1000 mV	40 kHz	35 kHz
10 V	40 kHz	35 kHz
100 V	500 kHz	500 kHz
1000 V	500 kHz	500 kHz

3-34. Sample/Hold On, Delay On, Any Trigger Source.

NOTE

When operating the instrument with Sample/Hold ON, the front panel SAMPLE RATE control must be fully counterclockwise to the HOLD position, and FILTER must be OUT.

3-35. In this mode of operation, the time between application of a trigger command and the resulting Hold command is $105 \mu\text{s} \pm 10 \mu\text{s}$. This is true whether triggering is internal or external through the Sample/Hold, Remote or BCD connectors. Maximum response time to within 0.01 % of final reading for a full-range step input voltage of either polarity is given in Table 3-3, and minimum input amplifier bandwidth in Table 3-2. External Sample/Hold trigger signal requirements are given in Figure 2-2. Requirements for external trigger applied through the BCD or plug-in Remote connector are given on Page 2-3 and in the plug-in Operating and Service Manual.

Table 3-3. Acquisition Time.

Range	3482A	3484A	3485A
100 mV	100 μs	70 μs	100 μs
1000 mV	70 μs	70 μs	70 μs
10 V	70 μs	70 μs	50 μs
100 V	70 μs	70 μs	—
1000 V	70 μs	70 μs	—

3-36. Sample/Hold Operating Characteristics.

3-37. Acquisition Time. Acquisition time is defined as the time required for the input amplifier to respond to a positive or negative full-range step input to within 0.01 % of final reading. Acquisition time varies with range and plug-in unit as shown in Table 3-3.

3-38. Aperture Time. Aperture time is defined as the time between application of a "hold" command in the Sample/Hold logic circuits and the actual "holding" of the signal for measurement. Aperture time is $110 \text{ ns} \pm 20 \text{ ns}$ for any method of triggering, and is independent of range or plug-in selection.

3-39. Measurement of a Step Input. Accurate Sample/Hold measurement of a full-range step input voltage (with Delay off) requires observance of the acquisition times shown in Table 3-3. A Sample/Hold trigger command may be applied at the end of the required acquisition time. Figure 3-3 illustrates measurement of a full-range step input both with Delay off and with Delay on. When operating with Delay on, a trigger command may be applied simultaneously with a step input voltage.

3-40. Ramp or Sine Wave Digitization. The Sample/Hold mode of operation may be used for digitization of a ramp or low-frequency sine wave input. The maximum $\Delta V/\Delta T$ for tracking is 10 % of range/ μs . Table 3-4 shows the ability to digitize a ramp or sine wave to the accuracy given.

Table 3-4. Ramp and Sine Wave Digitization.

Accuracy	Plug-in Unit and Range				
	3482 and 3484				
	100 mV	1000 mV	10 V	100 V	1000 V
$\pm 0.01 \%$	15 V/ μs 15 Hz	40 V/ μs 41 Hz	400 V/ μs 41 Hz	50 V/ μs 0.5 Hz	500 V/ μs 0.5 Hz
$\pm 0.1 \%$	15 V/ μs 15 Hz	400 V/ μs 41 Hz	4 kV/ μs 41 Hz	500 V/ μs 5 Hz	5 kV/ μs 5 Hz
$\pm 1 \%$	150 V/ μs 150 Hz	4 kV/ μs 410 Hz	40 kV/ μs 410 Hz	50 V/ μs 50 Hz	50 kV/ μs 50 Hz

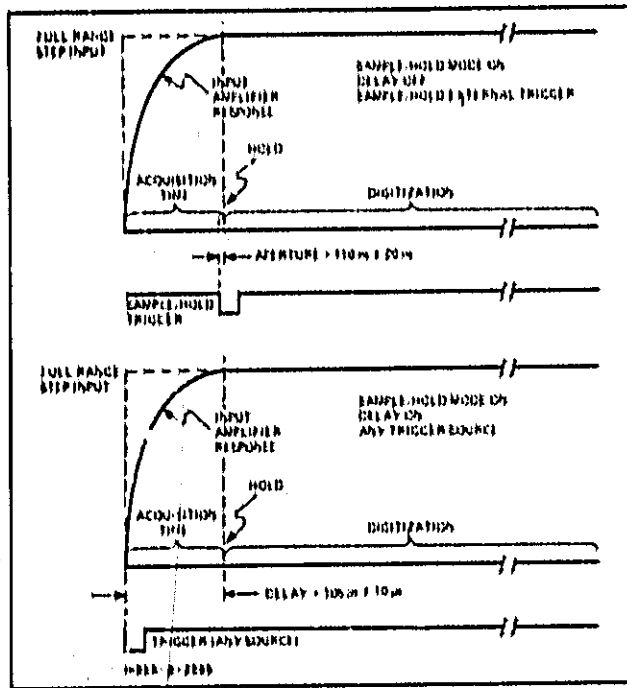

Figure 3-3. Sample/Hold Measurement of Full Range Step Input.

3-41. Noise Peak-to-peak noise, referred to the input, with Filter out (95 % of the time) is shown in Table 3-5.

Table 3-5. Peak-to-Peak Noise,

Range	3482A	3484A	3485A
100 mV	40 μV	40 μV	40 μV
1000 mV	0.4 mV	0.4 mV	0.4 mV
10 V	0.5 mV	0.5 mV	0.5 mV
100 V	30 mV	30 mV	---
1000 V	100 mV	100 mV	---

3-42. Analog Output. The Sample/Hold option provides an analog output which may be used with an oscilloscope to monitor such operations as ramp or sine wave digitization, peak measurements, or response time measurements. Figure 3-4 gives an example of the analog output waveform when monitoring sine wave digitization, using the "Sample/Hold ON, Delay OFF" mode.

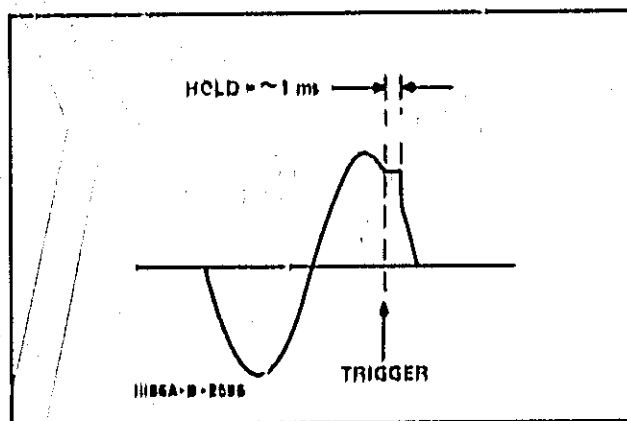

Figure 3-4. Sample/Hold Analog Output.

CAUTION

ANALOG OUTPUT LOW TERMINAL IS CONNECTED INTERNALLY TO INPUT LOW AND CIRCUIT GROUND. IF THE ANALOG OUTPUT IS USED, FLOATING MEASUREMENTS CANNOT BE MADE UNLESS THE INSTRUMENT CONNECTED TO ANALOG OUTPUT IS FLOATING.

3-43. Isolated BCD Output Option 004.

3-44. Option 004 provides eight columns of 1-2-4-8 coded BCD information. The Option 004 input and output signals are referenced to chassis (power line) ground, which is isolated from the LO input terminals and the 3480C/D circuit common. The Option 004 also provides five columns of numerical measurement information, range, function and polarity, and overload information. True state for all output signals is HIGH = 5 V, False, or LO = 0 to +0.5 V. Positive reference is +5 V and negative reference is 0 V (chassis ground). Interface connections and requirements are shown in Figure 2-3 (Section II).

3-45. In addition to the coded information, a Print Command output signal is provided at J13 pin 48. This signal goes positive at the beginning of the sample period and remains positive until approximately 50 microseconds after the end of the sample period. The negative-going transition of this signal is the Print Command. The voltage level of the positive portion of the signal may be either +5 V or +10 V, selected by means of a slide switch located on the BCD printed circuit board A5.

3-46. The Printer Holdoff connection (J13 pin 22) requires a voltage level of +5 V to +15 V to prevent the 3480C/D from sampling. A voltage level of 0 V to +0.5 V, or an open circuit, constitutes a free-run condition.

3-47. At the Interface Hold (Inhibit) connection (J13 pin 47), a ground connection (to J13 pin 50) or a level of 0 V to +0.5 V produces a HOLD condition. An open circuit or a voltage level of +2.4 V to +5 V allows the 3480C/D to free-run.

3-48. When the instrument is placed in the HOLD condition, either by an external signal or the front panel control, sampling may be initiated by an External Trigger (Encode) signal applied to J13 pin 46. Refer to Paragraph 3-24 and Figure 2-3 for remote trigger information.

3-49. A Digital recorder such as the Hip-Model 5055A may be used with the 3480C/D. The printer columns are numbered from right to left. Table 3-6 lists the information printed in each column for Option 004, both with a straight-through cable such as the Hip-562-16C, and with the 3480C installed in a Model 2070A Data Logger. Table 3-7 shows the numbers printed by a standard Hip-print wheel (+8421) in the Range, Function, and Polarity and

Table 3-6. Printer Information for BCD Output Option 004.

		Printer Column									
		10	9	8	7	6	5	4	3	2	1
3480C/D with straight-thru output cable.	3482A or 3484A	-	Polarity and Overload	Function	Range	Data Overrange	Data Thousands	Data Hundreds	Data Tens	Data Units	-
	3485A *	-	Polarity and Overload	Range	Scanner Channel Tens	Data Overrange	Data Thousands	Data Hundreds	Data Tens	Data Units	Scanner Channel Units
2070A	3482A or 3484A	-	Range	Zero	Polarity and Overload	Function	Data Overrange	Data Thousands	Data Hundreds	Data Tens	Data Units
	3485A *	-	Scanner Channel Tens	Scanner Channel Units	Polarity and Overload	Range	Data Overrange	Data Thousands	Data Hundreds	Data Tens	Data Units

Overload columns. In overload condition, the numbers printed in the numerical data columns will not necessarily correspond to the value of the input.

3-50. 2070A DATA LOGGER.

3-51. The Model 2070A Data Logger combines a Model

3480C Digital Voltmeter and a Model 5055A Digital Recorder in one convenient unit for ease of mounting and operation. Any of the 3480 series plug-in units may be used in the 2070A. Specific operating instructions are contained in the plug-in Operating and Service Manuals and the 2070A Operating Note.

Table 3-7. BCD Output.

BCD Code	Number Printed on 5055A	Polarity and O/L	Function	Range 3482A, 3484A		Range 3485A
				Volts	Ohms	
000	0	+	DC Volts		10 MΩ	100 mV
001	1	-	AC (AC) Volts	1000 V	1000 kΩ	1000 mV
010	2	+ and O/L	Ohms	100 V	100 kΩ	10 V
011	3	- and O/L	AC (DC) Volts	10 V	10 kΩ	
100	4		DC S/H or Ratio	1000 mV	1000 Ω	*100 mV
101	5		AC (AC) S/H or Ratio	100 mV	100 Ω	*1000 mV
110	6		Ohms S/H or Ratio			*10 V
111	7		AC (DC) S/H or Ratio			

* Range will appear in these positions for instruments with Sample/Hold if this operation is selected.

THEORY

SECTION IV THEORY OF OPERATION

4-1. INTRODUCTION.

4-2. This section describes operation of the circuits used in the Model 3480C/D mainframe. A separate Operating and Service Manual section for each plug-in drawer describes the plug-in circuits. The Model 3480C/D Digital Voltmeter employs the successive approximation method of determining the value of the input voltage as supplied to the mainframe by the plug-in. This voltage is compared to a succession of BCD weighted pulses developed from a reference voltage. The comparison sequence for the first two digits is illustrated in Figure 4-2. Any pulse resulting in a D/A level greater than the input level is rejected, but pulses which do not exceed the input level are retained. At the completion of the sample period, the combined value of all the retained pulses is displayed in the front panel readout. Reading from right to left in the display, the digits are referred to as the Units, Tens, Hundreds, Thousands and Overrange digits. The following paragraphs refer to the simplified block diagram shown in Figure 4-1.

4-3. PLUG-IN.

4-4. The primary function of the plug-in drawer is to provide a de voltage at its output that is proportional to the

de voltage, ac voltage, or resistance applied to the input terminals. This involves range and function selection, attenuator circuits, amplifiers and converters as necessary to accomplish the purpose of the particular plug-in drawer. Sample control circuits and filtering circuits are also contained in the plug-in. A rear panel connector is provided for remote control of range, function, sampling, filtering or other operations as required. Detailed information for each plug-in drawer is contained in a separate Operating and Service Manual section.

4-5. POLARITY AMPLIFIERS.

4-6. The output of the plug-in is 0 to ± 15 V (10 V full range), and is proportional to the de voltage, ac voltage or resistance applied to the input. The plug-in output voltage is applied to two unity-gain amplifiers. If the input voltage is positive, the output of the Non-Inverting Amplifier will be positive, causing the diode at its output to be reverse biased. The Inverting Amplifier, however, will have a negative output and the diode at its output will be forward biased. Consequently, the output to the Comparator Summing Junction will be negative. If the input voltage is negative, the situation is reversed and the output of the Non-Inverting Amplifier is now negative, again resulting in a negative output to the Comparator.

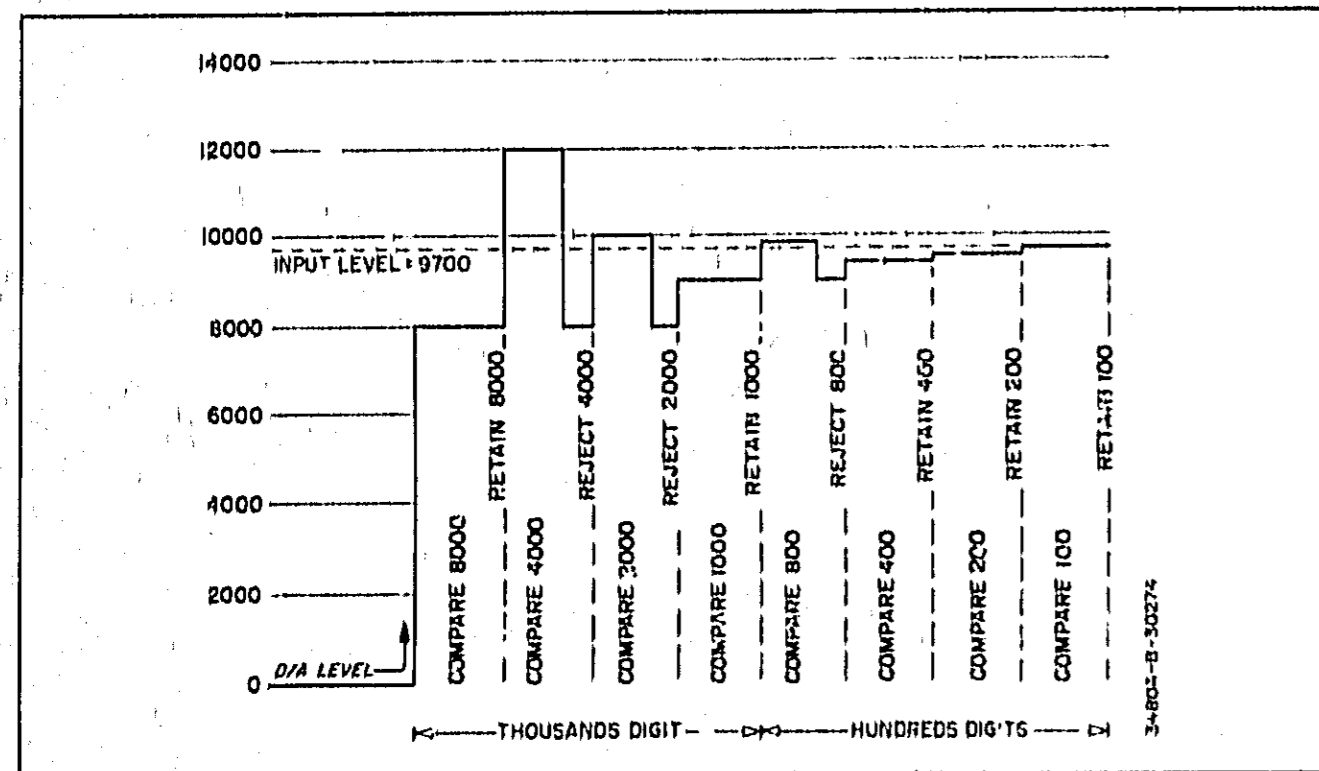

Figure 4-2. Successive Approximation Comparison Sequence

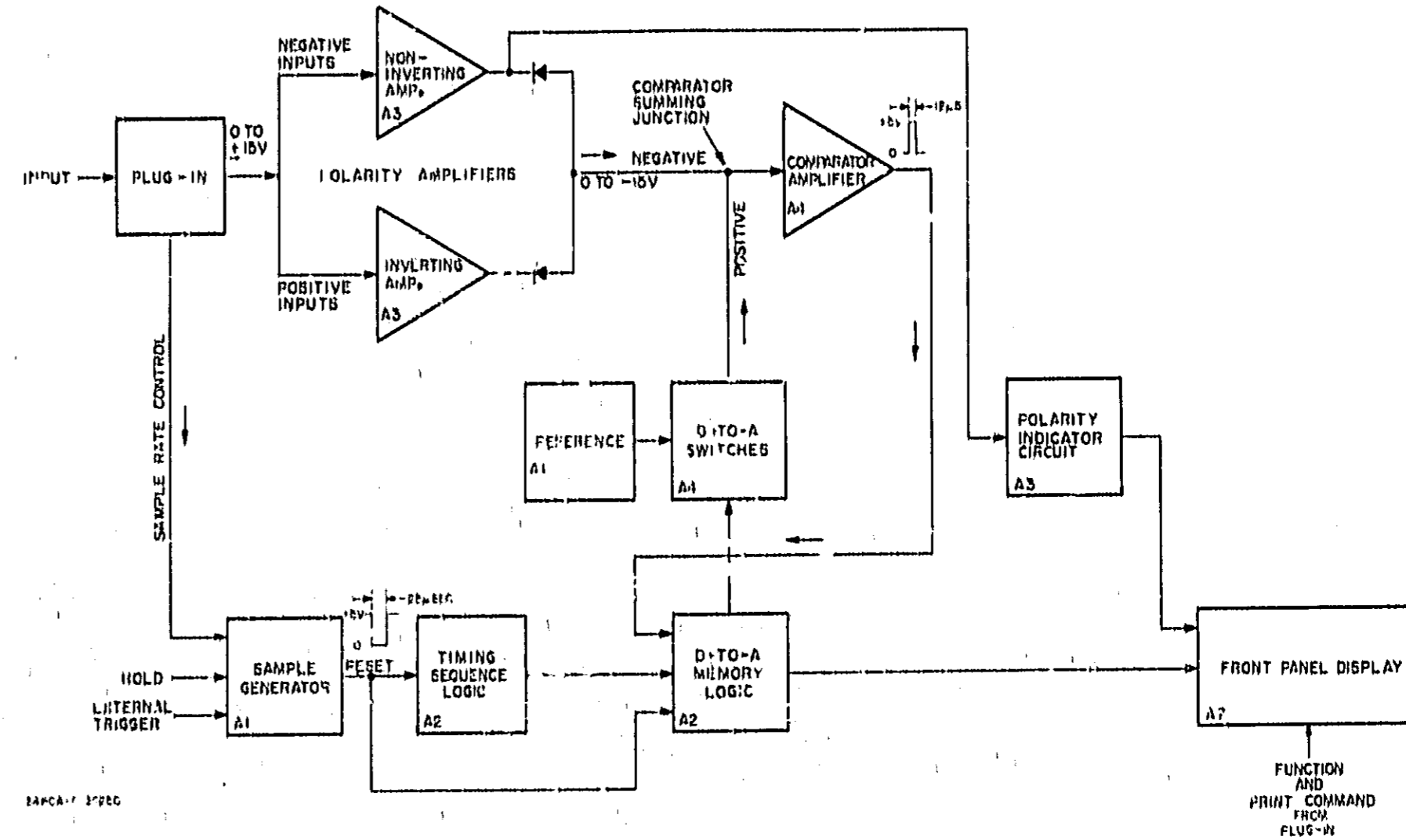

Figure 4-1. Simplified Block Diagram.

4-7. Both amplifiers are unity-gain operational amplifiers consisting of a differential stage, followed by a modified emitter follower and an output amplifier. The negative feedback from the emitter follower to the constant current source of the differential stage improves the common-mode rejection characteristic of the amplifier. Using both outputs of the differential stage to drive the base and emitter of the first transistor of the output amplifier makes use of the full voltage gain of the differential stage. This configuration also improves the common-mode rejection characteristic. The use of a constant current source in the final stage allows the output voltage to approach ± 20 V. The diode in the amplifier output is included in the feedback path to reduce the effect of the offset voltage of the diode.

4-8. A separate output from the Non-Inverting Amplifier is used to drive the polarity display circuits, and to provide BCD polarity information in instruments incorporating optional BCD output.

4-9. POLARITY INDICATOR CIRCUITS.

4-10. A separate output from the Non-Inverting Amplifier from a point ahead of the output diode, is used to determine the polarity shown in the front panel display. This signal is inverted and applied to a gating circuit which controls a pair of NAND gates operating as a flip-flop. The output of this flip-flop determines the polarity at the front panel.

4-11. If the output of the Non-Inverting Amplifier is positive, this signal is inverted to approximately 0 V, or "LOW", and applied to one input of NAND Gate 1 (see Figure 4-3). Because a LOW at either input of Gate 1 causes the output to be HIGH (+5 V), the resulting HIGH output is applied to one input of Gate 2. When the Clock Control signal goes HIGH during the sample period, Gate 1 output

remains HIGH because one input is still LOW. Both inputs to Gate 2 are now HIGH; consequently, its output goes LOW, causing the flip-flop output to be HIGH. A HIGH output from the flip-flop results in a positive indication in the display.

4-12. When the Non-Inverting Amplifier output is negative, this causes one input of Gate 1 to be HIGH. Since the Clock Control signal is LOW between sample periods, Gate 1 output will remain HIGH until the start of the next sample period, at which time it changes to LOW, causing Gate 2 output to be HIGH. At the same time, the LOW output of Gate 1 and the HIGH output of Gate 2 change the state of the flip-flop so that its output is now LOW. This results in a negative front panel display. Thus it can be seen that the state of the flip-flop, and consequently the front panel polarity, can be changed only during a sample period.

4-13. The emitters of the polarity indicator driver are grounded through the plug-in drawer. In the 3452A Multi-Function plug-in, this emitter grounding circuit is switched so that the polarity indicators are enabled only during dc voltage measurements.

4-14. COMPARATOR AMPLIFIER.

4-15. The input to the Comparator Amplifier is the algebraic sum of the two current inputs to the Summing Junction. The input current from the Polarity Amplifiers is a negative current equal to the input voltage divided by the Summing Junction input resistance. This may be expressed:

$$I_{in} = \frac{-|E_{in}|}{10^4 k}$$

The D/A current is a positive current equal to the reference

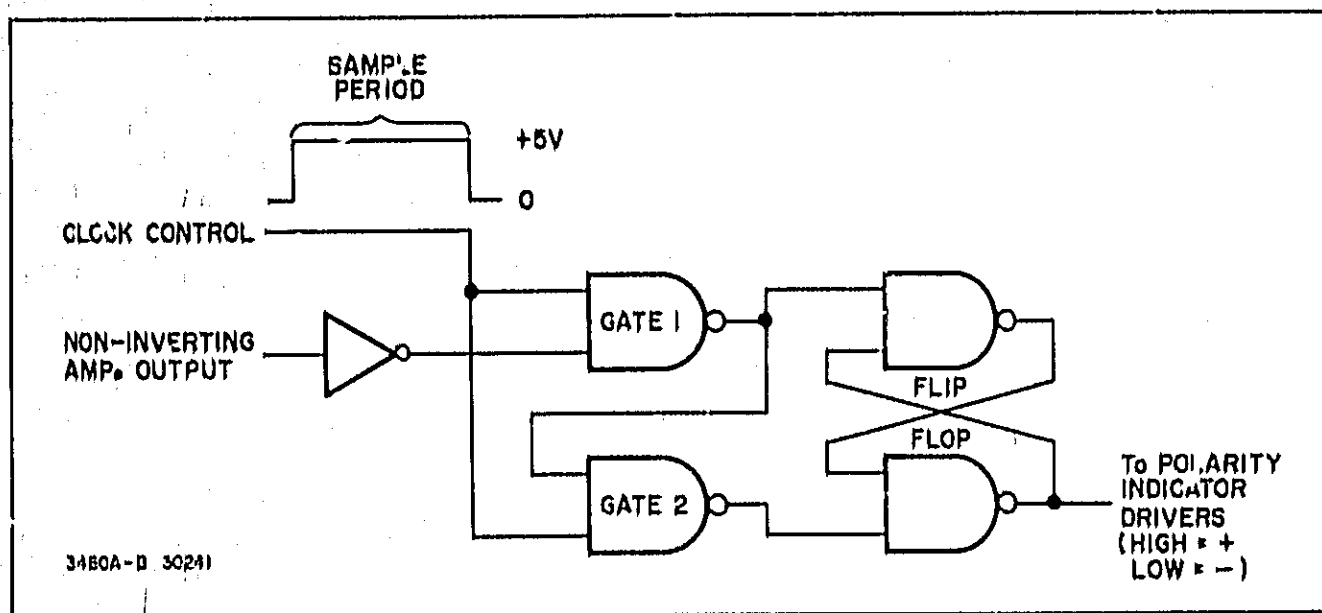

Figure 4-3. Polarity Indicator Circuit.

voltage divided by the parallel resistance of the D/A Switch circuits active at a given time.

4-16. The Comparator Amplifier is a high-gain inverting amplifier consisting of a differential stage, a modified emitter follower, and an output amplifier. The output is gated by the Comparator Enable signal from the Clock Multivibrator, as illustrated in Figure 4-4. If the value of $I_{D/A}$ exceeds I_{in} , the Comparator Amplifier output will be negative, or LOW. Then when the Comparator Enable signal goes LOW (true), the Gate output goes HIGH. This HIGH signal resets the D/A Memory Flip-Flop, rejecting that particular bit of information. The diode pair at the amplifier input serves to maintain that input at "virtual ground" potential until I_{in} and $I_{D/A}$ approach a null condition.

4-17. SAMPLE GENERATOR, WITH SINGLE CHANNEL PLUG-INS.

4-18. A relaxation oscillator drives the Reset Amplifier, producing a reset pulse which starts the Timing Sequence Logic circuits, resulting in a sample period. The oscillator frequency is determined by the SAMPLE RATE control on the plug-in front panel. This control may be set to the HOLD position, allowing the sample period to be initiated by the front panel pushbutton or by an external triggering circuit. The HOLD condition may also be obtained by remote connection to the Hold Amplifier in the Sample Generator circuits. By use of the SAMPLE RATE control, the rate may be varied from 1 sample/second to at least 25 samples/second. When the SAMPLE RATE control is set to HOLD, the 3480C/D may be triggered up to 1000 times per second by an external trigger signal.

4-19. Sample Oscillator and Reset Amplifier.

4-20. The Sample Oscillator and Reset Amplifier circuits are shown in Figure 4-5. When voltage is first applied to the circuit, Q82 and Q83 are biased ON and quickly reach saturation, causing the voltage at Q83 collector to be approximately +16 V. Current then flows into the lower side of C81. When this point approaches +16 V, both transistors turn OFF, and the voltage at Q83 collector drops to about +6 V. As current flows from C81 through

Q81 and the SAMPLE RATE control, the voltage at Q83 base drops to a point where the transistors again turn ON, completing the cycle. The voltage at the left side of C82 varies from about +6 V to +16 V. The positive-going edge of this pulse causes the Reset Amplifier to saturate, resulting in a Reset pulse of approximately 25 microseconds duration.

4-21. The SAMPLE RATE control regulates the rate of current flow from C81 during the time the transistors are OFF; and, consequently, controls the Sample Oscillator frequency. When the SAMPLE RATE control is set to HOLD, Q81 is turned OFF, disabling the oscillator.

4-22. Hold and Trigger Amplifiers.

4-23. When the Interface Hold and Printer Holdoff lines are in the free-run condition (Figure 4-6), Q85 is OFF and Q86 is ON. Diode CR84 is reverse biased; consequently, the circuit has no effect on the Sample Oscillator. A HOLD condition may be produced by grounding the Interface Hold line, or by applying +6 V to +15 V to the Printer Holdoff line. When either of these conditions is present, Q86 is turned OFF and CR84 is forward biased. This disables the Sample Oscillator by applying approximately +18 V to the base of Q83.

4-24. When the Hold Amplifier is in the HOLD state, Q88 is normally OFF, and Q87 is conducting. Grounding the Trigger line turns off Q87 and saturates Q88. This applies a negative pulse to the base of Q83 in the Sample Oscillator circuit, resulting in a single sample period. The Trigger line must then be open (or HIGH) for at least 50 microseconds to allow the circuit to recover before applying the next trigger signal. C85, R99 and R100 provide a slight delay in order to reject noise or switch contact bounce of 10 microseconds or less.

4-25. TIMING SEQUENCE LOGIC.

4-26. The Timing Sequence Logic circuits consist of the Clock Circuits, an 18-Pulse Counter, and the Counter Decoding Logic. The Reset pulse (LOW true) from the Sample Generator resets the Clock Control Flip-Flop to start the Clock Multivibrator, which drives the 18-Pulse

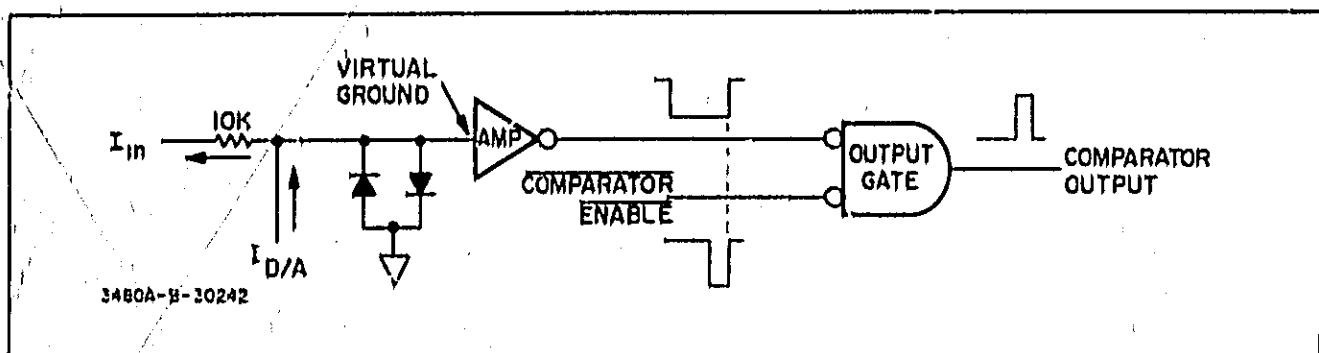

Figure 4-4. Comparator Amplifier.

Counter. At the end of the 18th pulse, the counter output sets the Flip-Flop to stop the Clock Multivibrator. Output voltage levels from the five binary stages of the 18-Pulse Counter are used to determine proper sequencing of the Digital-to-Analog (D/A) Memory Logic.

4-27. Clock Circuits.

4-28. The Clock Control Flip-Flop (Figure 4-7) is a bistable multivibrator. The Reset pulse changes the state of the flip-flop so that the Clock Control output is LOW. This signal turns off the transistor Clock Switch, allowing the Clock Multivibrator to free-run. The Clock Multivibrator output feeds the 18-Pulse Counter. At the trailing edge of the 18th pulse, an output (W) from the counter sets the Clock Control output to HIGH, saturating the Clock Switch and stopping the Multivibrator.

4-29. The Clock Multivibrator output appears as a series of 12-microsecond pulses with an amplitude of +5 V. The trailing, or negative-going, edge of each pulse changes the state of the first binary counting stage. A second output from the opposite side of the Clock Multivibrator, known as Comparator Enable, is used to gate the Comparator Amplifier output so that output pulses may be produced only at the proper times during the measurement sequence.

4-30. 18-Pulse Counter.

4-31. The 18-Pulse Counter is a series of five flip-flops, as illustrated in Figure 4-8. Each flip-flop is triggered by the negative-going output of the previous stage. At the start of the sample period, outputs S, T, U and V are LOW, while W output is HIGH. The trailing edge of the first clock pulse changes S output to HIGH, and the second pulse changes S output back to LOW. Normally, when S output goes LOW,

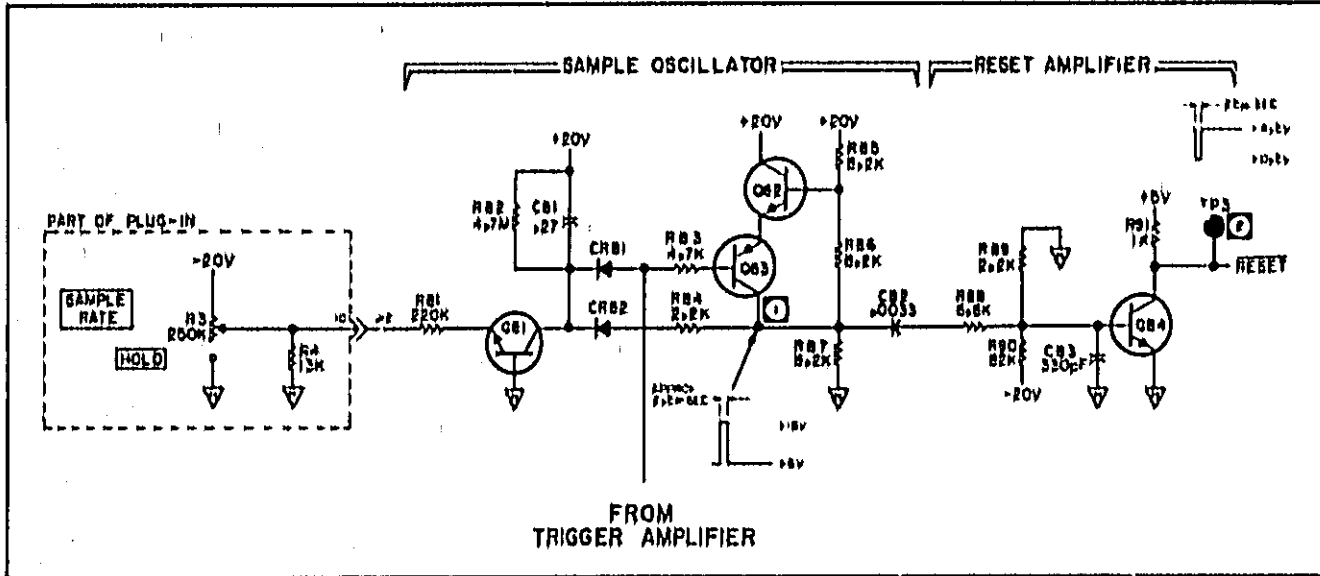

Figure 4-5. Sample Oscillator and Reset Amplifier.

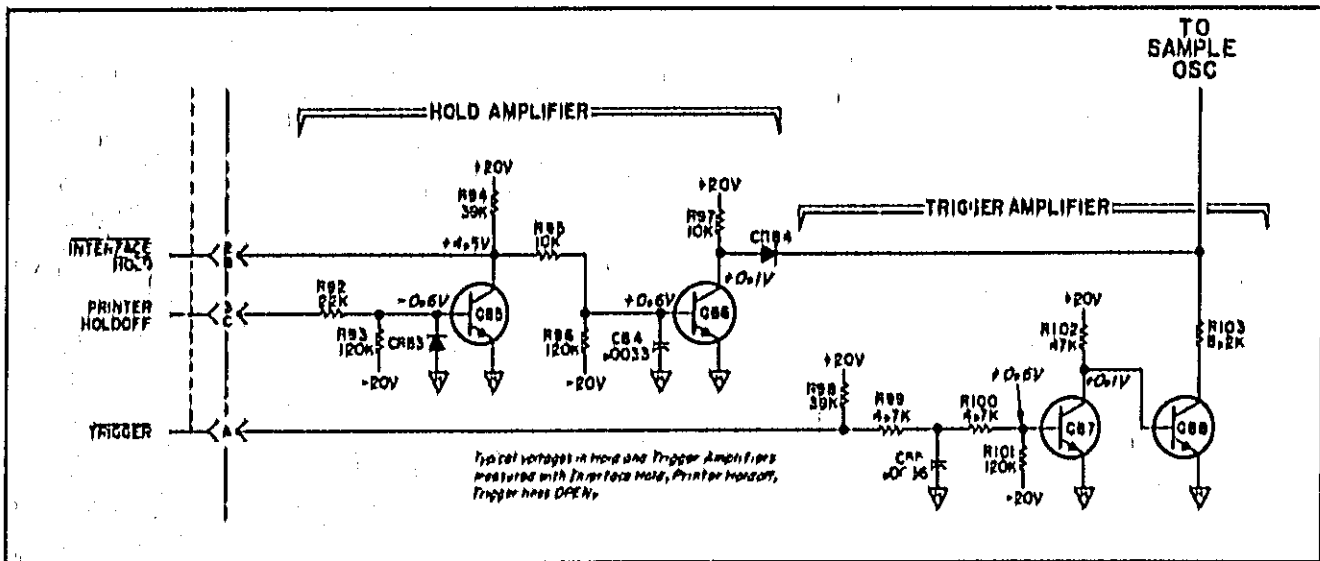

Figure 4-6. Hold and Trigger Circuits.

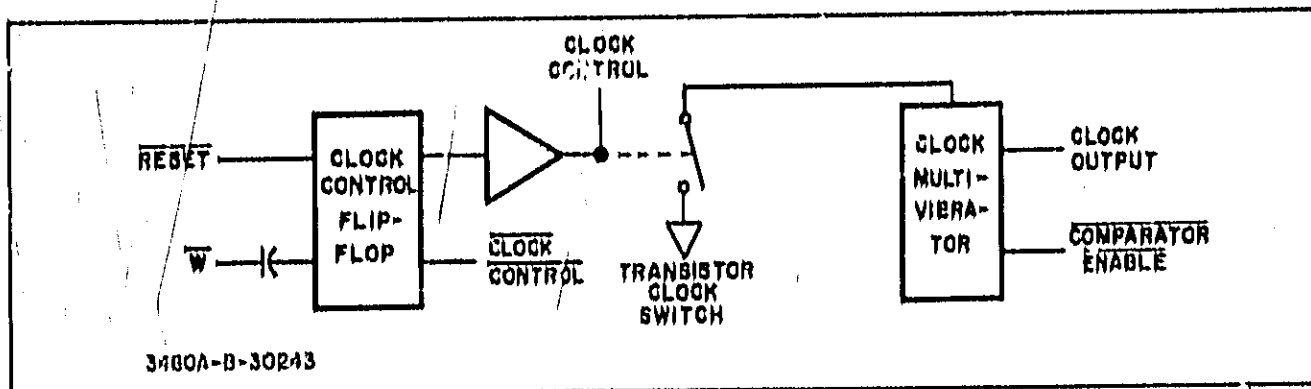

Figure 4-7. Clock Circuits.

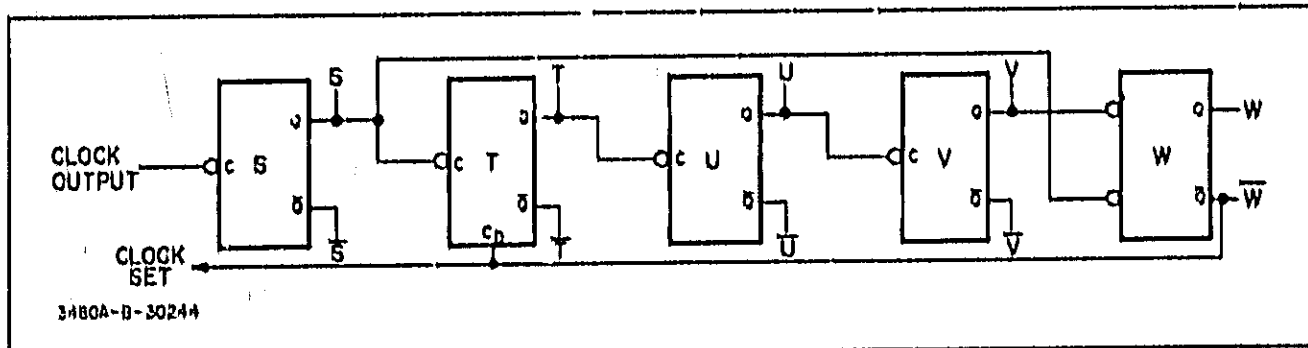

Figure 4-8. 18-Pulse Counter.

It should change the state of the T flip-flop. However, the LOW W output connected through a diode to the T input holds T so that it cannot change state. Instead, the S output changes the state of the W flip-flop, and the W output becomes HIGH. The following 16 pulses are counted in the normal binary manner. At the trailing edge of the 18th clock pulse, S, T, U, V and W outputs are all set to LOW. The LOW output from W sets the Clock Control output to HIGH, stopping the Clock Multivibrator.

4-32. Counter Decoding Logic.

4-33. The Counter Decoding Circuits are buffer amplifier stages which function as NAND gates. A typical circuit and the equivalent logic gate symbol are shown in Figure 4-9. All inputs to the circuit must be LOW in order to produce a HIGH output. The eight outputs from the Decoding circuits control the D/A Memory Logic to turn on the D/A switches in the proper sequence. The time relationship between the clock output, 18-Pulse Counter outputs and the Counter Decoding outputs is shown in Figure 4-10.

4-34. DIGITAL-TO-ANALOG MEMORY LOGIC.

4-35. Integrated circuit packages containing two flip-flops are used in the D/A Memory Logic circuits. Figure 4-11 shows the 8000 memory circuit as typical.

4-36. At the start of a sample period, the Delayed Reset pulse sets all flip-flops so that the 8000 output is HIGH. This might be called the "zero" condition. When both the 1000 and D inputs to the memory circuit go HIGH, the HIGH output from Gate 1 changes the state of the flip-flop. The 8000 LOW output turns on the 8000 D/A switch. If the resulting comparison at the input to the Comparator Amplifier indicates that the D/A voltage is greater than the input voltage the Comparator will produce an output pulse. This pulse, coupled into Gate 2 through isolation diode CR24, causes the flip-flop to return to the reset state. This turns off the D/A switch, rejecting the 8000 information. If, however, the 8000 bit from the D/A switch is not greater than the input voltage, there is no output from the Comparator and the 8000 flip-flop remains HIGH. In this case, the 8000 bit is retained.

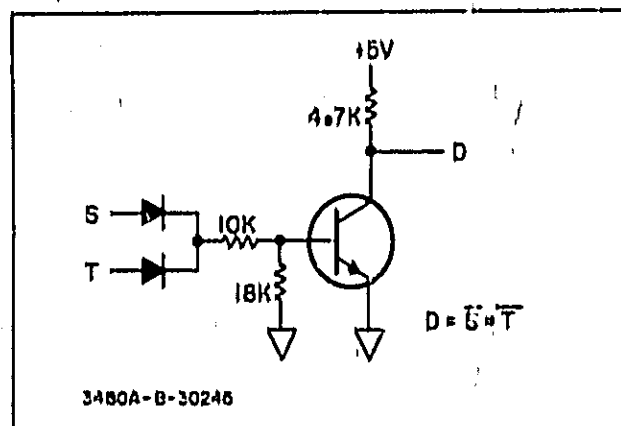

Figure 4-9. Typical Counter Decoding Logic Gate.

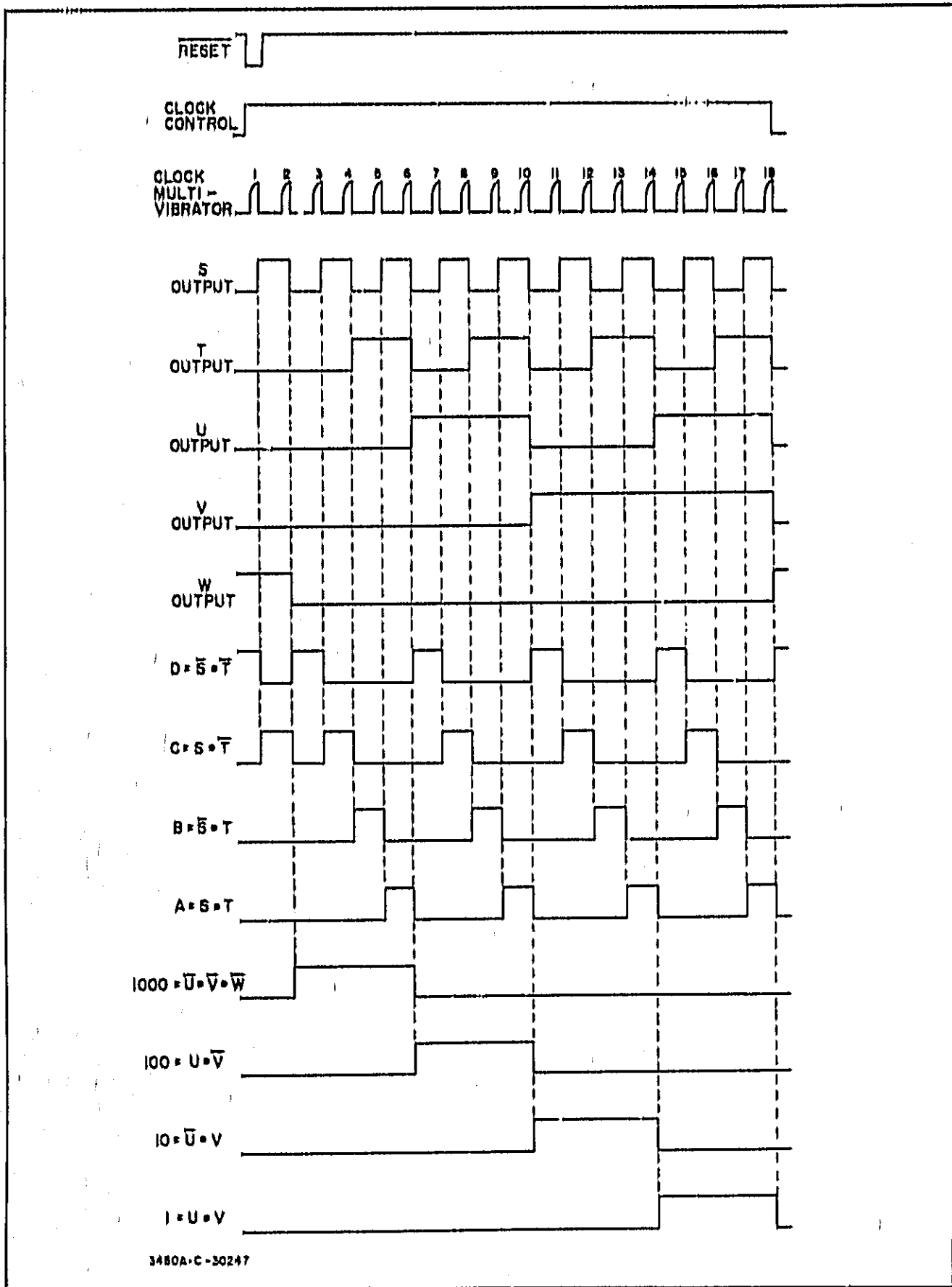

Figure 4-10. Clock and Counter Timing Sequence.

4-37. The diode CR19 between the comparator line and the 1000 line prevents the Comparator output from resetting the thousands flip-flops during the hundreds, tens or units comparison periods. During these periods, the 1000 line will be LOW, forward biasing CR19, and the Comparator line above isolation diode CR24 will then also be LOW.

4-38. A lockout circuit from the 8 flip-flop output to the 4 and 2 flip-flop inputs is provided in the hundreds, tens and units circuits. This prevents the 4 and 2 flip-flops from changing state when the 8 bit has been retained. If the 8 bit is retained, the 8 output will be LOW. This output is coupled to the "reset" inputs to the 4 and 2 flip-flops, forcing the 4 and 2 outputs to remain HIGH. Consequently, in the hundreds, tens and units memory circuits, if the 8 bit is retained, the 4 and 2 bits are not compared to the input. This precludes either the 4 or 2 information when the 8 bit has been retained, since either of these combinations exceeds the maximum of 9 which can be retained in these digits. The lockout circuit is not used in the thousands flip-flops because additional decoding is provided to make the 50% overrange reading possible.

4-39. Uprange and Downrange signals are provided for use in the plug-in units that have automatic ranging. When the 8000, 4000 and 2000 bits have been retained, indicating a measurement of 14000 or greater, this constitutes an uprange condition. Then at the end of the sample period when the Clock Control signal goes HIGH, the Uprange Gate output goes LOW, providing an uprange enable signal to the plug-in. If all of the thousands bits are rejected, this indicates a zero in the thousands digit display. This results in a reading of less than 10% of full scale and constitutes a downrange condition. So at the end of the sample period when the Clock Control signal goes HIGH, the output of the Downrange Gate goes LOW, providing a downrange signal to the plug-in.

4-40. DIGITAL-TO-ANALOG SWITCHES.

4-41. Two types of transistor switching circuits are employed as D/A switches. For the six most significant bits, where larger D/A currents are required, series switches are used. Shunt switches are used in the remaining circuits.

4-42. Series D/A Switches.

4-43. The 8000 switching circuit is shown in Figure 4-12 as an example of a series switch. When the 8000 bit is to be compared to the input, the 8000 line goes LOW, turning off Q8. This allows a positive voltage to be applied to the bases of Q9 and Q10. Q10 operates in the inverted mode; that is, it is turned on by the base-collector bias rather than the base-emitter bias. When operated in the inverted mode, the emitter to collector resistance of the transistor is much less than it is when operated in the normal manner. This lower resistance is necessary because of the higher current levels involved in the six most significant bits.

4-44. The value of the D/A current in the series switching circuits is equal to $E_{REF}/R_{D/A}$. In the 8000 circuit, $R_{D/A}$ is adjusted so that $I_{D/A} = 0.8 \text{ mA}$. The switching current (I_{SW}) must be approximately three times the value of the current being switched ($I_{D/A}$), so some means of compensating for this difference must be provided in order to maintain a nearly constant load on the reference supply. Q9 is turned on at the same time as Q10, providing a compensating current path. R_{SW} determines the value of I_{SW} , and R_{COMP} determines the value of the compensating current I_{COMP} . In the series switching circuits, $I_{D/A} + I_{COMP} \approx I_{SW}$.

4-45. Shunt D/A Switches.

4-46. In the D/A switching circuit shown in Figure 4-13A, it is apparent that when the 100 line goes LOW, the

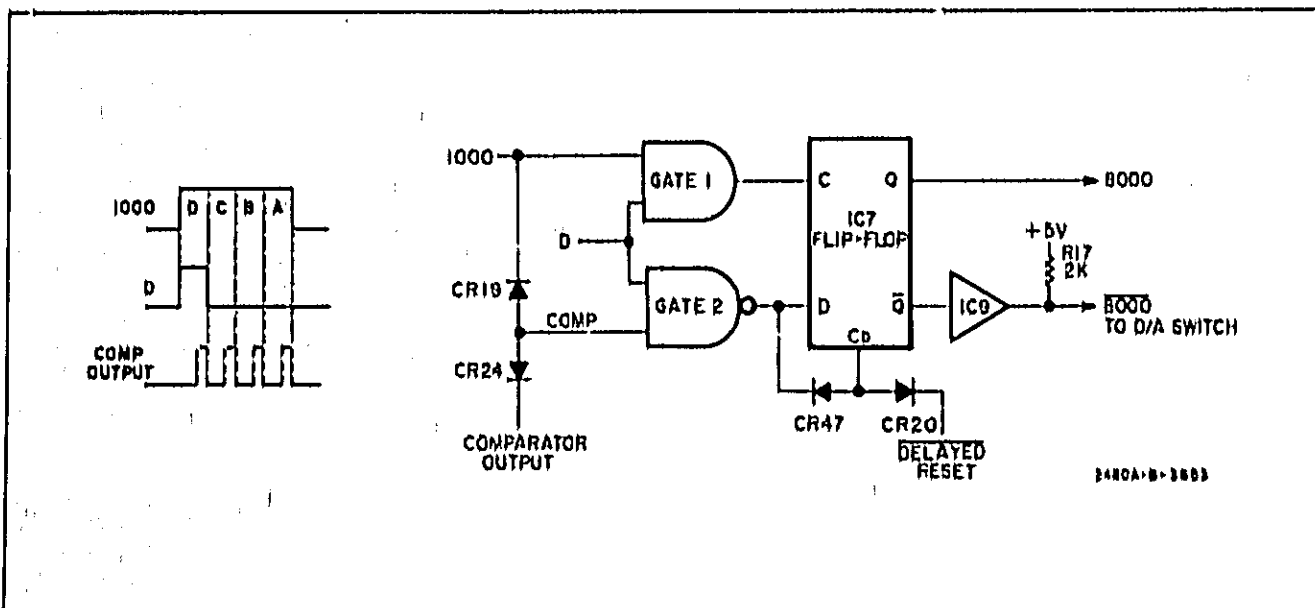

Figure 4-11. Typical D/A Memory Logic Circuit.

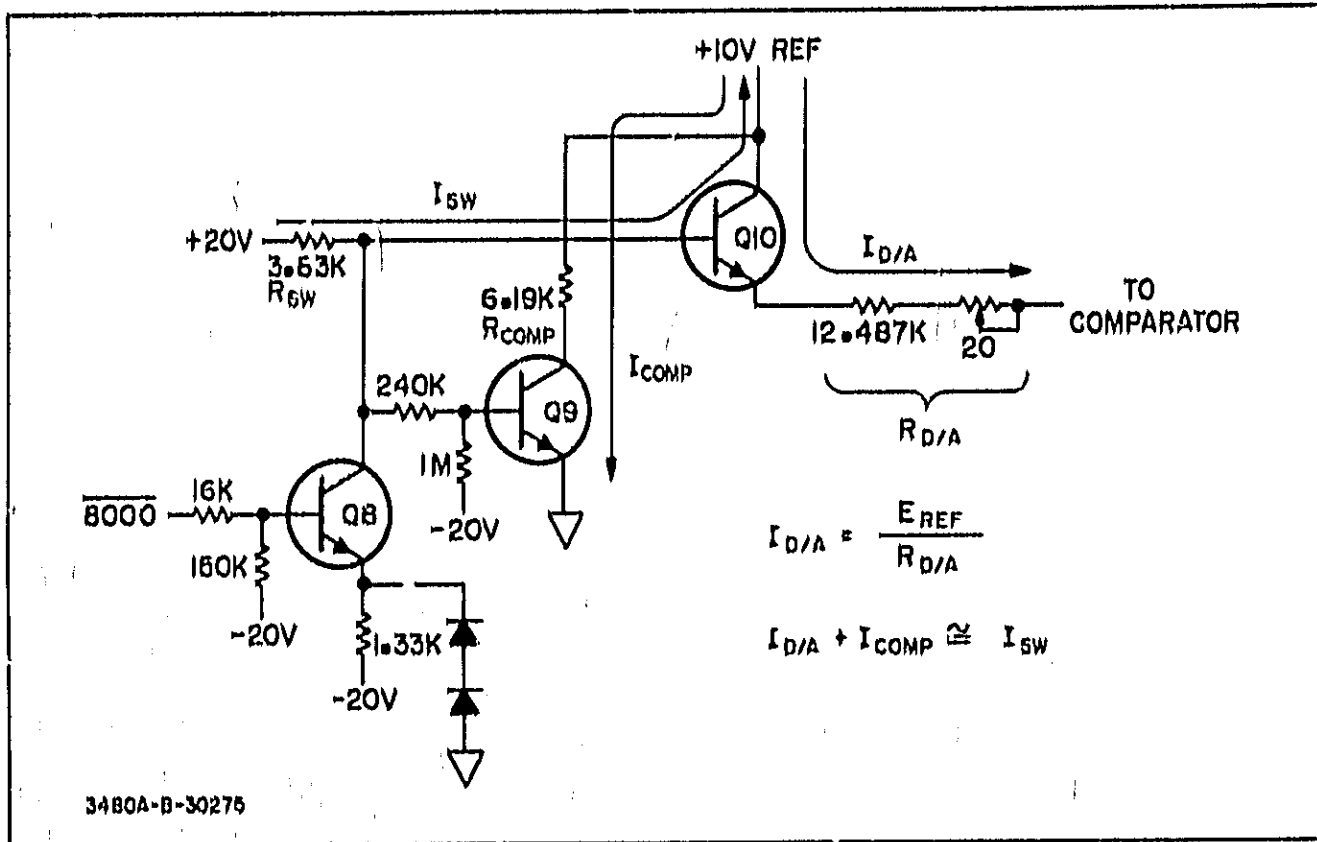

Figure 4-12. Series D/A Switch.

transistor switch turns off. This allows current to flow from the Reference voltage to the Comparator. In this circuit, $I_{D/A} = E_{REF}/R_{IA} + R_{IB}$. When the $\overline{100}$ line is HIGH, the switch is on and the voltage at point A becomes essentially zero, allowing no current to flow to the Comparator.

4-47. The switching circuit shown in Figure 4-13B is only slightly different. In order to keep resistor values low enough to be practical, another resistor, R2, has been added which is essentially in parallel with R1B. In this circuit, $I_{D/A}$ is equal to the voltage at point B divided by R1B. Since R1A and R1B are equal, the value of either resistor may be referred to as R1. The formula for determining $I_{D/A}$ then becomes:

$$I_{D/A} = \frac{E_{REF}}{R_1 (2 + \frac{R_1}{R_2})}$$

4-48. COMPARISON SEQUENCE.

4-49. Figure 4-14 illustrates the time relationship of the various logic signals, including the Comparator Output. Figure 4-15 is an example of the comparison sequence of the Thousands and Hundreds digits when the Input is 9900. The comparison action continues through the other two digits. Any comparison which causes the D/A level to exceed the input level will be rejected. At the end of the

sample period, the D/A level equals the input level, and the decimal value of all the bits retained is displayed at the front panel. Note that in the example shown in Figure 4-15, the 8 bit of the hundreds digit is retained; consequently, the 4 and 2 bits are not compared for this digit, as explained in Paragraph 4-38.

4-50. DISPLAY.

4-51. The display units, except the overrange digit, contain a binary-to-decimal decoder and a latch. Print Command signal from the plug-in unit occurs at the end of the sample period and latches the display at the data value computed during the sample period. This holds the display constant during the sample period.

4-52. OVERRANGE.

4-53. For a display of 10000 and greater, the thousand's binary data must be converted into BCD data to work the thousand's and ten-thousand's (overrange) display digits. Inverters and gates IC1 through IC4 supply a 1 to the overrange digit and a 0 through 5 to the thousand's digit during an overrange display. IC5 provides latching capability for the overrange digit that is not provided by the display IC.

4-54. OVERLOAD.

4-55. On overload (reading > 14999), dash marks are substituted for the five least significant display digits by

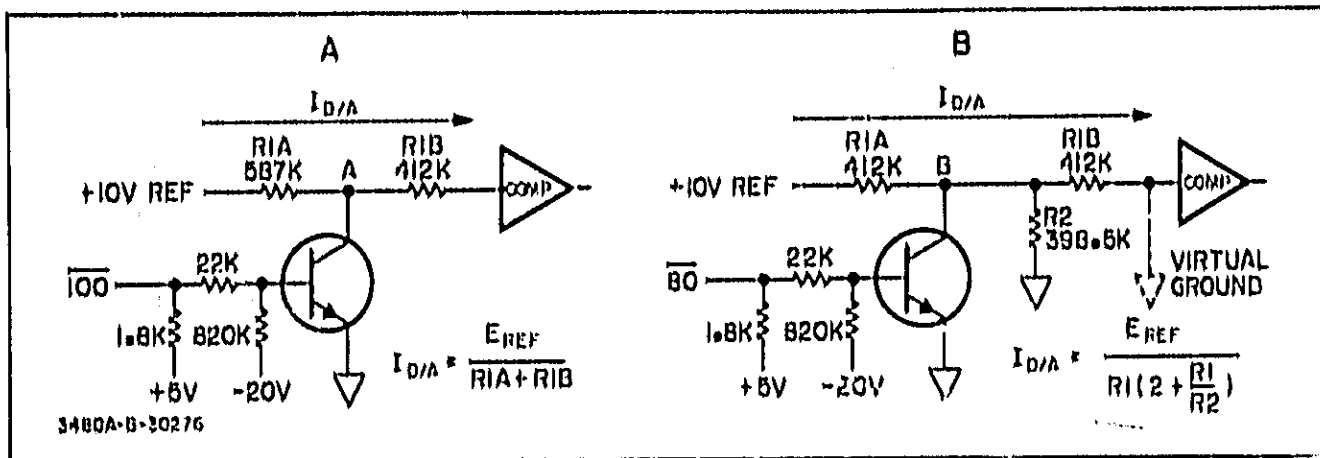

Figure 4-13. Shunt D/A Switches.

gates IC3, IC5, IC6 and IC8. This is done by sending number 13 to the display units. Diodes CR9 through CR12 detect the overload condition of 15000 by monitoring the thousand's binary data.

4-56. POWER SUPPLIES.

4-57. A block diagram of the power supply is shown in Figure 4-16, Page 4-11. All regulated voltages are controlled directly or indirectly by the reference diode A1CR61 in the +10V Regulator. Six diodes CR62, CR63, CR42, CR41, CR32 and CR31 allow raw supply voltages to take over the duty of the +30V and -30V feedback voltages, should these two voltages drop. This makes it possible to troubleshoot the supplies even though there are feedback loops. Furthermore, there are jumper wires at the regulator outputs which may be cut to determine whether a regulator itself is bad or is just being loaded down.

4-58. RANGE AND FUNCTION DISPLAY.

4-59. Signals which light the Function and Decimal indicators are supplied by circuits in the plug-in drawer.

4-60. SAMPLE/HOLD OPTION 001.

4-61. In the instrument equipped with the Sample/Hold Option 001, the Sample/Hold Amplifier Assembly A13 replaces the Polarity Amplifier Assembly A3 used in other instruments. The component designations in the following explanation refer to the schematic diagram, Figure 7-9.

4-62. Sample/Hold Amplifier.

4-63. The Sample/Hold Amplifier consists of two main parts, a non-inverting amplifier and an integrating amplifier. This combined circuit operates as an inverting unity-gain amplifier, with the voltage across the integrating capacitor, A13C7, being equal to E_{in} (the Sample/Hold Amplifier input). During Sample/Hold operation, a "Hold" command is given at the beginning of a measurement. This command causes a field effect transistor (FET) switch, A13Q8, to

open the input to the Integrating Amplifier while a measurement is taken. The instrument then measures the voltage stored on the Integrating capacitor. At the completion of the measurement, the FET switch is again closed, allowing the amplifier to follow any change in input voltage.

4-64. When the FET switch (A13Q8) is turned off, its internal capacitance causes a small change in the voltage across the integration capacitor. To offset this voltage change, a second FET switch, A13Q10, and a capacitance, A13C9, equal to the Integrating capacitance are used at the other input to the amplifier, and switched simultaneously with A13Q8. Also, during the Hold period, another FET switch, A13Q1, is turned on, grounding the input to the Sample/Hold Amplifier.

4-65. Polarity Amplifiers.

4-66. Integrated circuit operational amplifiers are used in the Polarity Amplifier circuits. The output of the Integrating Amplifier is applied to both the Inverting and Non-Inverting Amplifiers simultaneously, and diodes at the amplifier outputs ensure that the output to the Comparator is always negative.

4-67. The operation of the Polarity Indicator Circuit is the same as in the standard instrument, which is described in Paragraph 4-9.

4-68. Sample/Hold Enable.

4-69. Sample/Hold operation may be enabled by setting the rear panel MODE switch to ON, or by grounding J14 pin J with the MODE switch in the REMOTE position. This causes the output of the IC buffer amplifier to be LOW, applying forward bias to the light emitting diode in A12IC2. This turns on the photosensitive transistor and applies a positive voltage to the base of A13Q13. Pin 4 of NAND Gate A13IC6 is then LOW, causing the output to be HIGH, applying a positive voltage to the emitter of A13Q16, thus enabling the Hold signal to turn this transistor on and off.

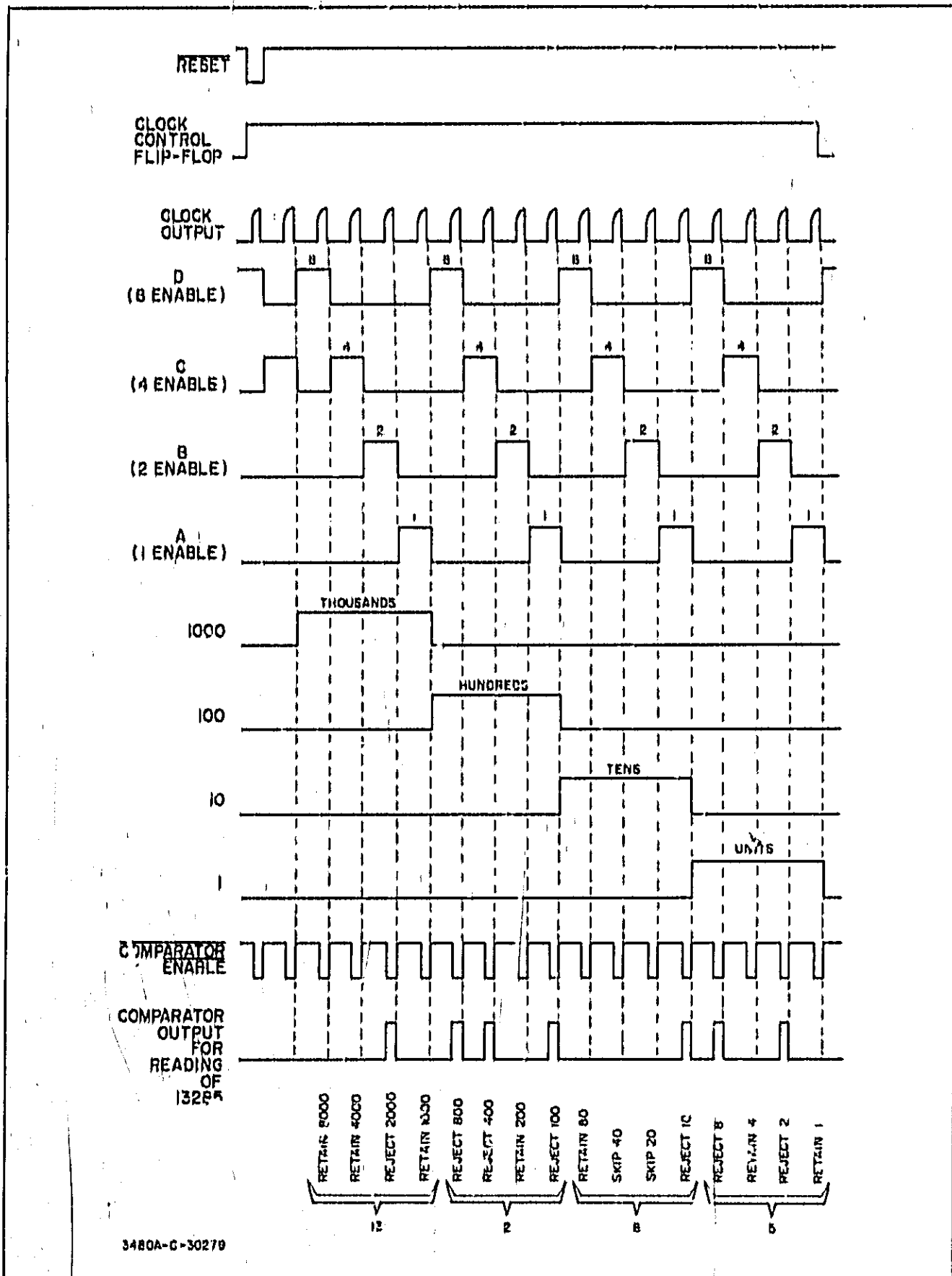

Figure 4-14. Logic Waveform Sequence.

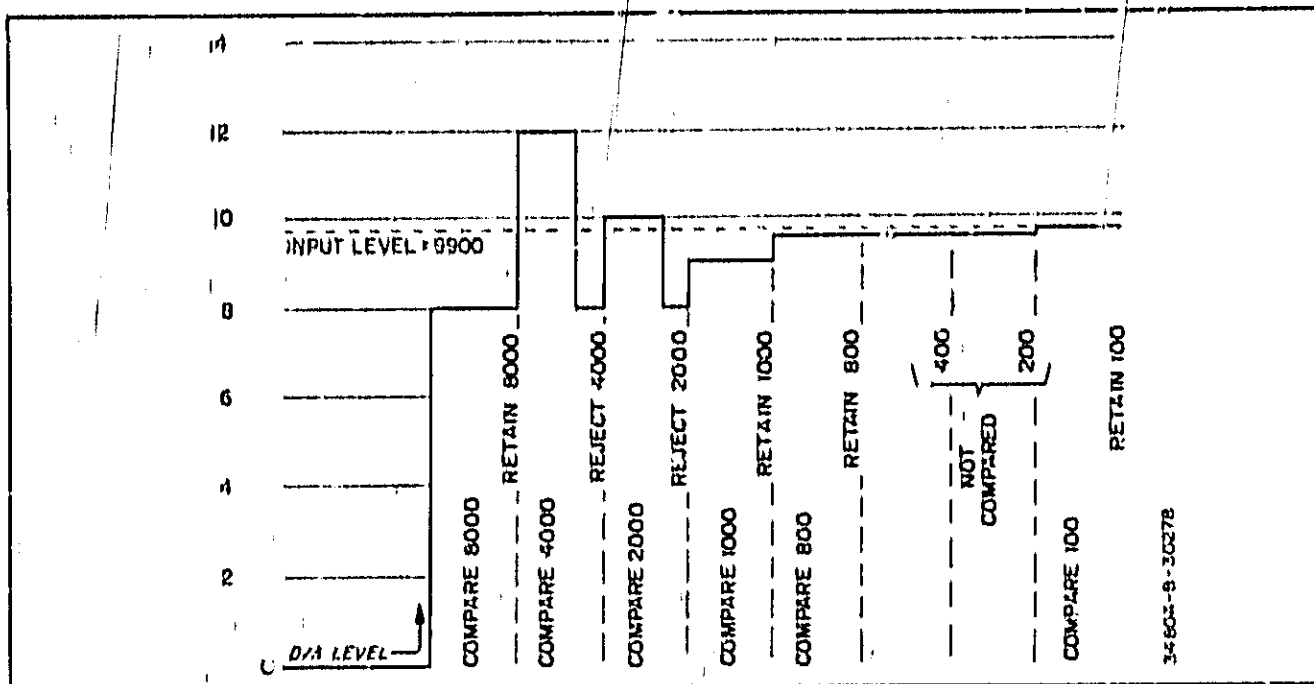

Figure 4-15. Comparison Sequence Example.

4-70. Automatic Sampling.

4-71. In the automatic sampling mode of operation, or when an external trigger is applied through the Remote or BCD connector, the Hold command is initiated by the Clock Control signal (from A2). The positive Clock Control pulse triggers a delay one-shot, whose output is gated with the Clock Control signal by a dual-input NAND gate. The gate output (A131C6 pin 3) goes LOW at the end of the 90 μ s one-shot pulse, providing a Hold signal to the Sample/Hold switching circuits. The gate output remains LOW until the end of the measurement period. Timing waveforms are shown in Figure 4-17. The 90 μ s delay provides sufficient time for the input amplifier to respond to a full-range step input of voltage.

4-72. External Trigger (Non-Delayed Mode).

4-73. When the non-delayed mode of operation is selected,

pins 9 and 13 of A131C6 are HIGH, enabling the other inputs to these NAND gates to control their outputs. Upon application of an external trigger command through the Sample/Hold connector, a positive pulse is applied to pin 12 of A131C6 and to pin 12 of the one-shot circuit, A131C4. The gate output at pin 11 immediately goes LOW, initiating a Hold condition, and the one-shot output to pin 10 of A131C6 maintains the Hold condition for approximately 120 μ s. About 15 μ s after application of a trigger command, the Trigger Delay one-shot circuits (A131C5) cause a Reset pulse to be generated, initiating a Clock Control pulse. This signal then maintains the Hold condition for the duration of the measurement period, as explained in Paragraph 4-70. As a result, in the non-delayed mode, the Hold condition begins immediately upon application of an external trigger command and is maintained throughout the measurement period.

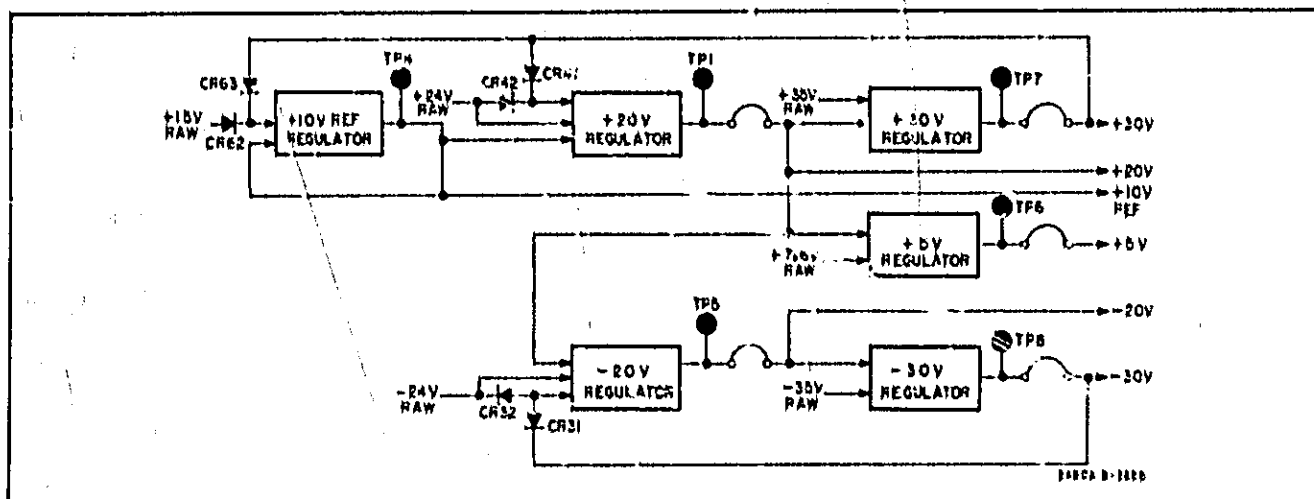

Figure 4-16. Power Supply Block Diagram.

4-74. External Trigger (Delayed Mode).

4-75. The delayed mode of operation is selected by setting the rear panel DELAY switch to ON, or by grounding J15 pin 11 with the DELAY switch in the REMOTE position. This causes the collector of A13Q12 to be LOW, forcing the two gate outputs (A13IC6 pins 8 and 11) to be HIGH. Consequently, a trigger command applied to the other inputs to these gates will have no effect. The Trigger Delay circuits then cause a Reset pulse to be generated, resulting in a Clock Control pulse which produces a Hold command as explained in Paragraph 4-70. In this mode of operation, then, the Hold command begins approximately 105 μ s after application of an external trigger command, permitting application of a de step input voltage simultaneously with the trigger command.

4-76. Interface Circuits.

4-76. The interface circuits located on Assembly A12 provide isolation between the program and external trigger circuits and the 3480C/D internal circuits and input common terminal. The program and external trigger connections are referenced to chassis ground. Isolation in the external trigger circuit is provided by a pulse transformer, and by light coupled isolators in the program circuits. An external trigger command produces a 4 μ s positive pulse to the Sample/Hold Logic circuits.

4-78. Isolated BCD Output Option 004.

4-79. Option 004 provides eight columns of 1-2-4-8 binary coded output information, "1" state positive. The Option 004 input and output signals are referenced to chassis (power line) ground, which is isolated from the LO input terminal and the 3480C/D circuit common. Option 004 information is obtained through integrated circuit inverters (Figure 4-18) and is available thru a 50 pin BCD rear panel connector (Figure 2-3, Section II). LO reference is chassis (power line) ground. HIGH reference of +5 V is obtained from the isolated regulator which supplies power to the isolated circuits. Power for this regulator is supplied by a winding on the primary side of the transformer shields.

4-80. The heart of Option 004 is the Binary Counter IC3 which is driven by the Print Command signal and the 300 kHz \pm 20% Oscillator to develop timing signals A, B and C. See Figures 4-18 and 7-11. Signals B and C multiplex (address) the nine columns of BCD data at IC4 thru IC7 so that the individual 1-2-4-8 bits of information are passed serially through the light isolators to the shift registers. Here they are stored and shifted to the appropriate A, B, C and D output lines by timing signal A.

4-81. Print Command begins the 50 μ s output cycle, and the counter Preset is 1 (the inverse of signal D) ends the cycle. The counter is synchronous with Clear, meaning that Clear is not actually accomplished until the proper Clock level occurs. This assures proper starting of the timing signals for the output cycle.

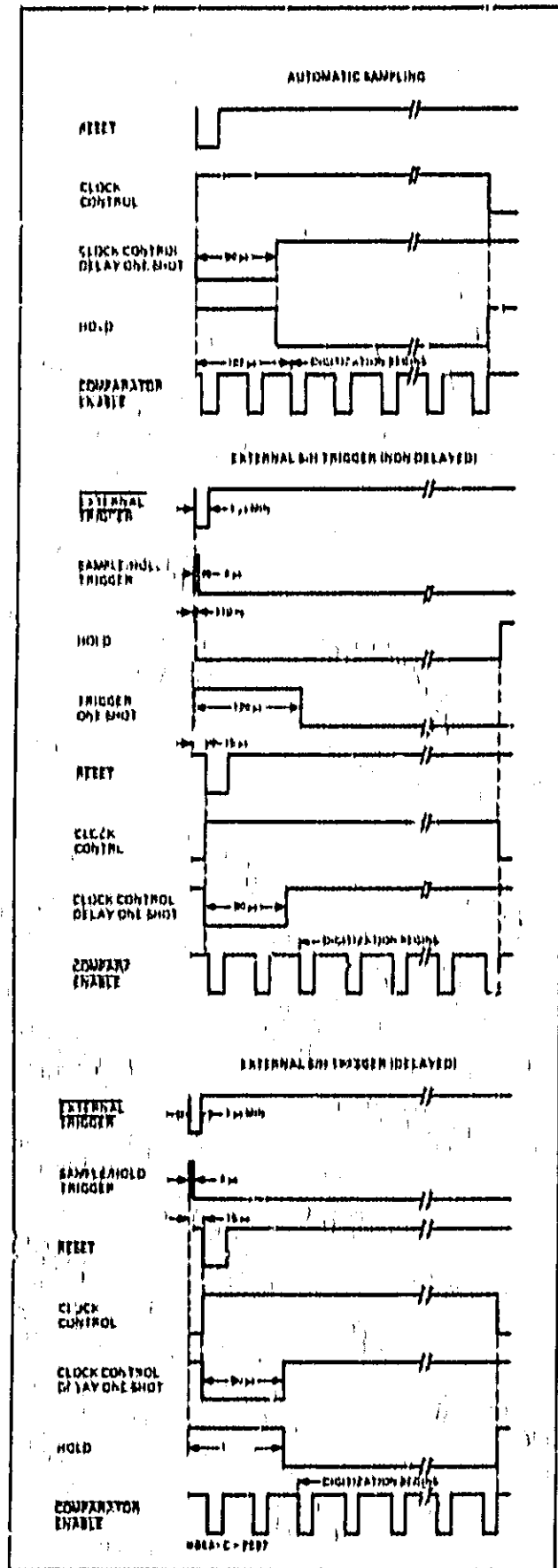

Figure 4-17. Sample/Hold Timing.

4-82. Figure 4-1B shows the route of the typical 800 data bit through the Isolated BCD assembly. The serial output of the multiplexer, which contains three other data bits in addition to 800, is coupled through the light isolator by

varying the leakage current of the output diode with light emitted from the input diode. The output transistor then supplies the shift register with the four serial data bits. The 800 bit is shifted to the D output by timing signal A.

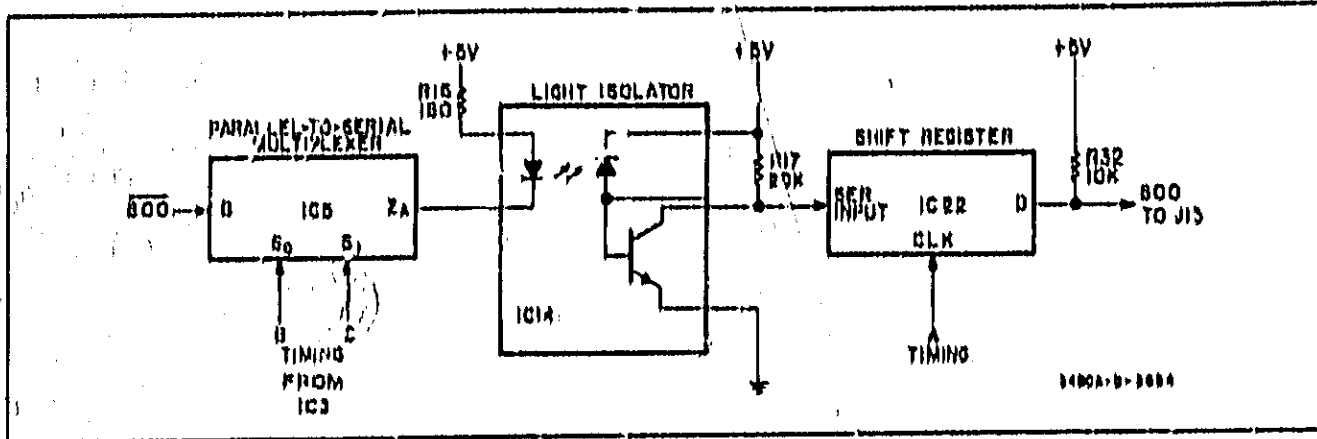

Figure 4-1B, Isolated BCD Output Circuit.

MAINTENANCE

SECTION V MAINTENANCE

5-1. INTRODUCTION.

5-2. This section contains information necessary to maintain the Model 3480C/D Digital Voltmeter. Included are performance checks, adjustment procedures and troubleshooting.

5-3. TEST EQUIPMENT REQUIRED.

5-4. Recommended test equipment for maintaining and checking performance of the Model 3480C/D is listed in Table 5-1. Test instruments other than those listed may be used if their specifications equal or exceed the required characteristics.

Table 5-1. Required Test Equipment.

Instrument Type	Required Characteristics	Use	Recommended Model
DC Standard	Output continuously variable from 0 to 1000 Vdc Accuracy: $\pm 0.005\%$	Performance Checks Adjustments Troubleshooting	hp-740B DC Standard/ Differential Voltmeter
Digital Recorder	1-2-4-8 BCD "1" state positive	Performance Checks (Option 004)	hp-6065A Digital Recorder
DC Voltmeter	Range: 1 mV full scale to 300 V full scale Must be floating	Troubleshooting	hp-412A DC Vacuum Tube Voltmeter
Oscilloscope	Bandwidth: dc to 450 kHz Sensitivity: 0.005 V/cm Sweep: 0.1 ns/cm	Troubleshooting	hp-140* Oscilloscope with hp-1401A and 1421A Plug-ins
DC Digital Voltmeter	Accuracy: $\pm 0.01\%$ Input Impedance: $> 10^9 \Omega$ Resolution: 5 digit	Adjustments	hp-3460B Multifunction Meter
Resistors	10 kilohm $\pm 5\%$ 100 kilohm $\pm 0.02\%$	Troubleshooting Troubleshooting	hp-0683-1035 hp-0811-0354

PERFORMANCE CHECKS

5-5. SCOPE OF CHECKS.

5-6. All specifications concerning measurement accuracy and input characteristics are dependent upon the plug-in unit used in the Model 3480C/D. Consequently, performance checks to verify accuracy, common-mode rejection, etc., are contained in the individual plug-in manual sections. The following checks verify operation of the Option 001 Sample/Hold circuits and the BCD output information for Option 004.

5-7. SAMPLE/HOLD CHECK (Option 001).

5-8. The accuracy of the dc voltmeter operation of the 3480C/D and plug-in unit must be verified before checking

the Sample/Hold operation. Use the procedure given in the appropriate plug-in manual section to check voltage accuracy. The following procedure requires a dc standard (hp-740B). This procedure checks operation both with a steady input and with a step input voltage.

a. Set 3480C/D plug-in controls to 10 V dc range, FILTER OUT, SAMPLE RATE to maximum. Connect Guard terminal to Low. Set rear panel Sample/Hold MODE and DELAY switches to OFF.

b. Connect dc standard to 3480C/D input and adjust standard output to +10.0000 V. 3480C/D display should be +10.000 V ± 0.002 V.

c. Set SAMPLE RATE to HOLD, rear panel MODE switch to ON. Press and release front panel TRIG push-

button, 3480C/D display should again be $+10,000 \text{ V} \pm 0,002 \text{ V}$.

d. Return MODE switch to OFF. Adjust de standard output to $+1,00000 \text{ V}$, with 3480C/D still on 10 V range. Press and release TRIG pushbutton, 3480C/D display should be $+1,000 \text{ V} \pm 0,001 \text{ V}$.

e. Set Sample/Hold MODE to ON, DELAY to ON (SAMPLE RATE still set to HOLD).

f. Change de standard output to $+10,0000 \text{ V}$.

g. Press and release TRIG pushbutton one time, Display should change to $+10,000 \text{ V} \pm 0,002 \text{ V}$.

h. Repeat steps b through g using a negative input (-10 V).

5-9. BCD OUTPUT CHECK (Option 004)

5-10. A de standard (chip-7409) and a digital recorder such as the $\mu\text{-}800$ Model 5055A are needed for this check. BCD coding of the printer must be 1-2-1-8. State positive. Columns are numbered from right to left. Table 5-2 lists the information printed in each column when a straight-thru cable is used. If the 3480C is installed in a 2070A Data Logger, refer to the 2070A Operating Note for the correct printer format.

a. Connect digital recorder to BCD Output Connector J13. Connections are shown in Figure 2-3.

b. Connect de standard to input terminals. Connect Guard to Low. Set standard output so that 3480C/D numerical readout is 1111. Recorder columns 6 through 2 should print 01111.

Table 5-2. Information Printed, Option 004.

Printer Column	Information Printer	
	3482A, or 3484A	3485A
1	zero	Units Channel I.D.
2	Numerical data	Numerical data
3		
4		
5		
6		
7	Range	Tent Channel I.D.
8	Function	Range
9	Polarity and Overload	Polarity and Overload
10	random number	random number

c. Adjust de standard to produce 3480C/D numerical displays shown in Table 5-3. Printout should correspond to display in each case.

Table 5-3. Numerical Information Printout.

3480C/D Display	Column	Recorder Printout				
		6	5	4	3	2
1111		0	1	1	1	1
2222		0	2	2	2	2
4444		0	4	4	4	4
7777		0	7	7	7	7
8888		0	8	8	8	8
0000		1	0	0	0	0

d. Set Range switch to positions shown in Table 5-4. Printout should be as indicated for each range. Input voltage is immaterial in checking range.

Table 5-4. Range Printout.

Range		Column 7 3482A or 3484A	Column 8 3485A
100 mV	100 Ω	5	0
100 mV	1000 Ω	4	1
10 V	10 k Ω	3	2
100 V	100 k Ω	2	
1000 V	1000 k Ω	1	
	10 M Ω	0	

e. Select those functions shown in Table 5-5 which are within the capabilities of the plug-in and options incorporated in the 3480C/D and plug-in unit. Since the 3485A has only the dc vol's function, no function printout is provided for this plug-in unit. The printout in column 8 should be as shown in Table 5-5 for the 3482A or 3484A plug-in units.

Table 5-5. Function Printout.

Function	Column 8
DC Volts	0
AC (AC) Volts	1
Ohms	2
AC (DC) Volts	3
DC or S/H	4
AC (AC or S/H)	5
Ohms or S/H	6
AC (DC) or S/H	7

f. Set plug-in Range and Function to 10 Vdc. Set de standard output to voltages shown in Table 5-6, except that if the plug-in unit is a 3485A, do not use the $\pm 16 \text{ V}$ checks. Column 9 should print the number shown in each instance.

CAUTION

DO NOT APPLY INPUT GREATER THAN $\pm 15,000 \text{ V}$ TO 3485A, OR DAMAGE TO THE INSTRUMENT MAY RESULT.

Table 5-6. Polarity and Overload Printout.

Input	Column 9
$+1,000 \text{ V}$	0
$+1,000 \text{ V}$	1
$+16,000 \text{ V}$	2
$+16,000 \text{ V}$	3

NOTE

If AC or Ohms function is selected, column 9 will print 0 except for Overload condition, when printout will be 2.

g. If a 3485A plug-in unit is used for this check, set Last Channel selection to 50, Channel Delay to .125. Set Mode to Single Scan and press Initiate pushbutton. Columns 7 and 1 should print correct channel identification numbers.

5-11. PRELIMINARY INFORMATION.

5-12. The following procedures should be performed only after it has been determined from the Performance Checks that the Model 3480C/D is out of specifications. Access to adjustments is gained by removing the 3480C/D top cover. Figure 5-1 shows the location of adjustments in all instruments except those with Sample/Hold Option 001, and Figure 5-3 shows the location of adjustments in Option 001 instruments. Adjustments must be performed in the order given in this procedure. Paragraphs 5-13 through 5-23 apply to all instruments except those with Option 001, and Paragraphs 5-24 through 5-31 apply to instruments with Option 001.

5-13. POWER SUPPLY ADJUSTMENT.

5-14. A dc differential voltmeter (hp-3420A/B) or a dc digital voltmeter able to resolve 0.1 mV on the 10 V range (hp-3450B) is required for this adjustment.

a. Turn on 3480C/D with plug-in unit installed and allow to warm up for one hour. A plug-in unit is necessary to provide normal loading of the power supplies.

b. Short INPUT terminals and set SAMPLE RATE to HOLD.

c. Connect a dc differential voltmeter or digital voltmeter between A1TP4 (+10 V REF) and INPUT Low and adjust A1R67 (+10 V ADJ) for voltage reading of $+10.0000 \text{ V} \pm 0.0002 \text{ V}$.

d. Check other regulated voltages shown in Table 5-7.

Table 5-7. Power Supply Voltages.

Measurement Point	Voltage
TP7	$+80 \text{ V} \pm 0.01 \text{ V}$
TP1	$+50 \text{ V} \pm 0.04 \text{ V}$
TP6	$+5 \text{ V} \pm 0.1 \text{ V}$
TP5	$+20 \text{ V} \pm 0.08 \text{ V}$
TP8	$+30 \text{ V} \pm 0.05 \text{ V}$

5-15. CALIBRATION INPUT.

5-16. If the plug-in unit dc amplifier is known to be accurate and linear, the plug-in may be left in place and the dc standard connected to the input terminals for the following procedures. The plug-in RANGE and FUNCTION must be set to 10 Vdc. However, if the plug-in is NOT known to be accurately calibrated, it should be removed, and the dc standard should be connected to A3TP4 and A3TP2 (6 and 2). Connecting A1TP1 to A1TP2 causes the instrument to sample approximately 25 times per second. Removing this connection produces a HOLD condition. Connect J12 pin 48 to pin 49, and A2TP2 to A3TP2.

5-17. If desired, a test fixture can be constructed to replace the plug-in unit for use in the following adjustment procedures. A suggested schematic is shown in Figure 5-2.

5-18. AMPLIFIER ZERO ADJ (All Except Option 001).

5-19. A dc standard (hp-740B) and a dc voltmeter (hp-412A) are required for these adjustments.

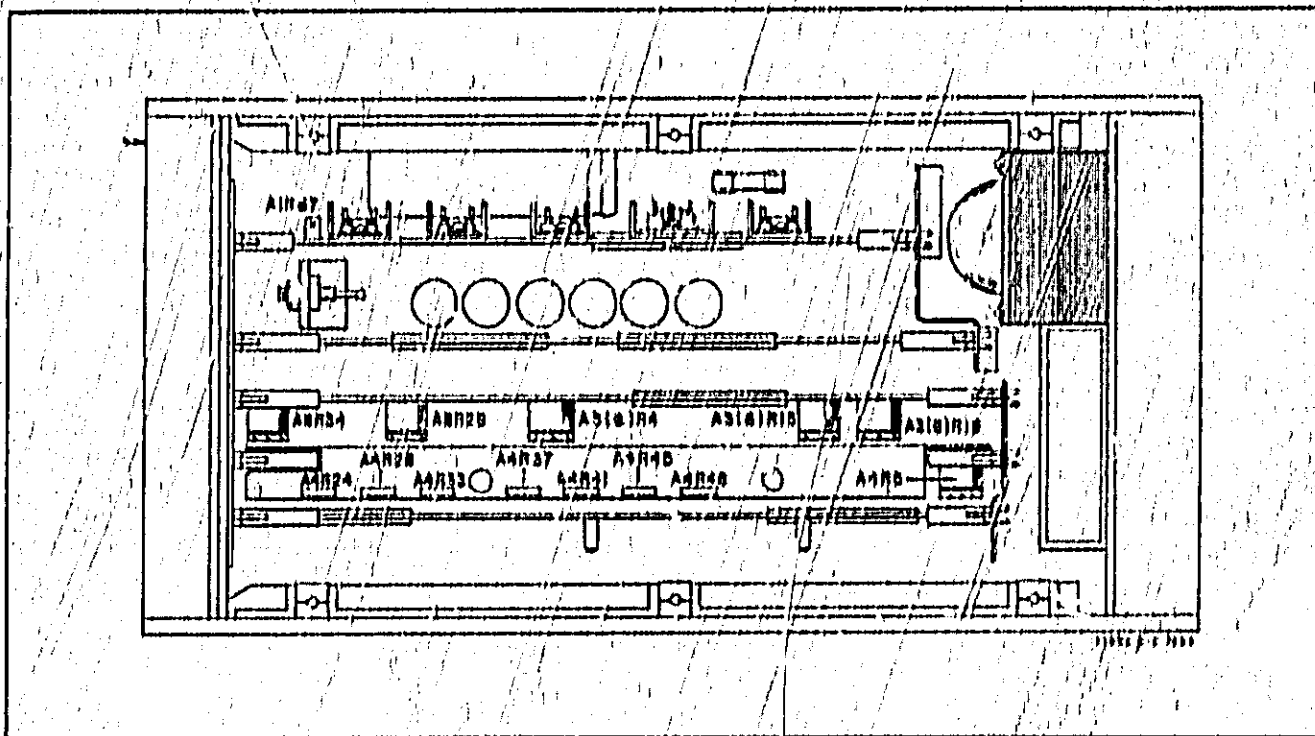

Figure 5-1. Location of Adjustments, All Instruments Except Option 001.

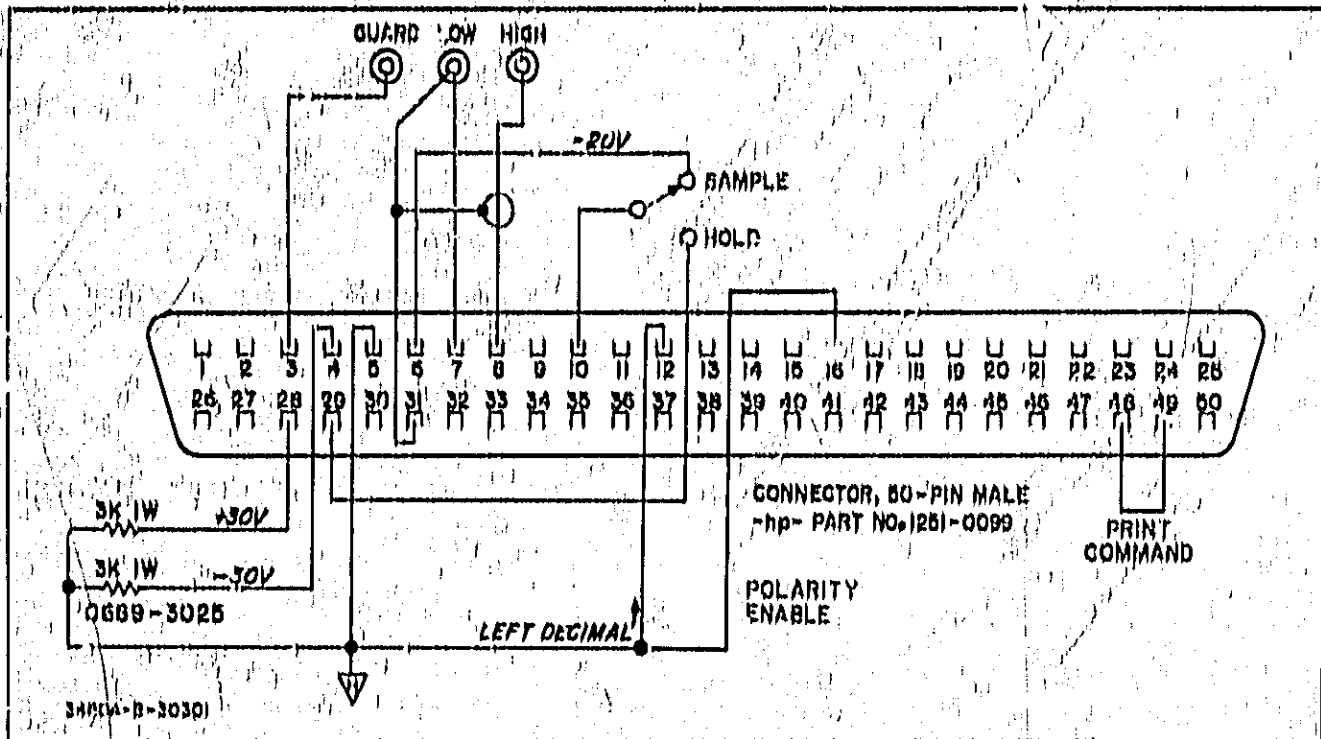

Figure 5-2. Suggested Test Fixture Schematic.

a. Connect negative side of dc standard output to A3TP4 or Input High (see Paragraph 5-15) and positive side to A3TP2 or Input Low. Set standard output to 0.0005 V.

b. Connect a dc voltmeter between A3TP3 and the same ground point used in step a.

c. If a plug-in is being used, set SAMPLE RATE fully clockwise. If plug-in is removed, connect A1TP1 to A1TP2 to cause instrument to sample. These test points are on the lower part of the Power Supply Assembly, toward the rear of the instrument. Also connect J12 pin 48 to pin 49, if a plug-in is not used.

d. Adjust Neg Amp Zero A3R4 for dc voltmeter reading as near -0.5 mV as possible. Disconnect voltmeter.

e. Adjust Comp Zero A4R5 (at rear of Comparator Assembly) to cause front panel display to flash alternately between -0.000 V and -0.001 V.

f. Reverse polarity of dc standard connections so that +0.0005 V is applied to A3TP4 (or Input High).

g. Adjust Pos Amp Zero A3R11 to cause display to flash alternately between +0.000 V and +0.001 V.

5-20. D/A CURRENT ADJUSTMENTS (All Except Option 001).

5-21. A dc standard (hp- 740B) is required for these adjustments.

a. Connect negative side of dc standard output to A3TP4 (or Input High) and positive to A3TP2 (or Input Low). Adjust standard output to 0.2005 V.

b. Adjust A4R48 to cause front panel display to flash alternately between -0.200 V and -0.201 V.

c. Set dc standard output to voltages shown in Table 5-8 and adjust control indicated to obtain proper display in each case.

Table 5-8. D/A Current Adjustments.

DC Standard Output	Adjust Control	Alternating Display
+0.2005	A4R41	+0.200 V to -0.201 V
+0.4005	A4R4	+0.400 V to -0.401 V
+0.8005	A4R4	+0.800 V to -0.801 V
+1.0005	A4R37	+1.000 V to -1.001 V
+2.0005	A4R33	+2.000 V to -2.001 V
+4.0005	A4R28	+4.000 V to -4.001 V
+8.0005	A4R24	+8.000 V to -8.001 V

d. Adjust dc standard output so that 3480C/D display flashes alternately between -9.999 V and -10.000 V. DC standard setting should be between -9.9991 and -9.9999 V.

e. Perform the checks listed in Table 5-9. The dc standard setting should be within the limits shown in each case. If not, repeat the Amplifier Zero adjustments in Paragraph 5-18 and the D/A Current Adjustments in this paragraph.

5-22. INVERTING AMP GAIN ADJ (All Except Option 001).

5-23. A dc standard (hp- 740B) is required for this adjustment.

- a. With de standard connected as in Paragraph 5-21 set standard output to cause 3480C/D display to flash alternately between $-9,990$ V and $+9,991$ V.
- b. Reverse polarity of de standard output.
- c. Adjust Pos Amp Gain A3R15 to cause display to flash alternately between $+9,990$ V and $+9,991$ V.

Table 5-9, Calibration Check,

Alternating Display	DC Standard Output
$0,000$ V to $10,000$ V	$0,0001$ V to $0,0000$ V
$0,000$ V to $0,001$ V	$0,0002$ V to $0,0008$ V
$7,776$ V to $7,777$ V	$7,7761$ V to $7,7769$ V
$0,332$ V to $0,333$ V	$0,3322$ V to $0,3328$ V
$0,000$ V to $0,000$ V	$0,0002$ V to $0,0008$ V

5-24. AMPLIFIER ZERO ADJUSTMENT (Option 001).

5-25. A de standard (hp-740B), a digital voltmeter with $>10^8 \Omega$ input impedance and $\pm 0,01\%$ accuracy (hp-3450B), and a dc voltmeter (hp-412A) are required for these adjustments. Location of adjustments for Option 001 instruments is shown in Figure 5-3.

- a. Set rear panel MODE switch to OFF. Connect short circuit between A13TP8 and A13TP4 (ground).
- b. Connect de voltmeter between A13TP1 and A13TP2. Adjust A13R6 for voltmeter reading as near zero as possible on its most sensitive range.
- c. Remove voltmeter from A13TP1 and TP2 and connect between A13TP10 and A13TP4.
- d. Remove short circuit from A13TP8 and A13TP4. Connect de standard to A13TP8 and A13TP4 or to Input

Terminals (see Paragraph 5-15). Set de standard output to $+0,0015$ V.

- e. Adjust A13R38 fully counterclockwise.
- f. Adjust A13R23 for de voltmeter reading of $+1,5$ mV. Disconnect voltmeter.
- g. Adjust Comp Zero A4R5 to cause front panel display to alternate equally between $+0,001$ and $+0,002$ V.
- h. Reverse polarity of de standard output ($-0,0015$ V) and adjust A13R38 to cause display to alternate between $-0,001$ V and $-0,002$ V. If this adjustment can be made correctly, proceed to step i. However, if A13R38 has insufficient range, perform steps 1 through 6 below.

- 1) Replace jumper wire 1 or 2 below A13R38, if either has been removed.
- 2) Connect de voltmeter between A13TP10 and ground, A13TP4.
- 3) Apply $+0,025$ V input from de standard and adjust A13R23 for de voltmeter reading of $-0,025$ V $\pm 0,0005$ V.
- 4) Reverse polarity in input voltage.
- 5) Adjust A13R38 from one extreme to the other, noting the de voltmeter reading. If reading is always more positive than $-0,025$ V, cut and remove jumper wire 1. If reading is always more negative than $-0,025$ V, remove jumper wire 2. If readings include $-0,025$ V, do not remove either jumper. Disconnect de voltmeter.
- e) Repeat steps d through h.
- i. Set rear panel MODE switch on ON. Adjust A13R31 to cause display to alternate between $-0,001$ V and $-0,002$ V. Turn MODE switch OFF.

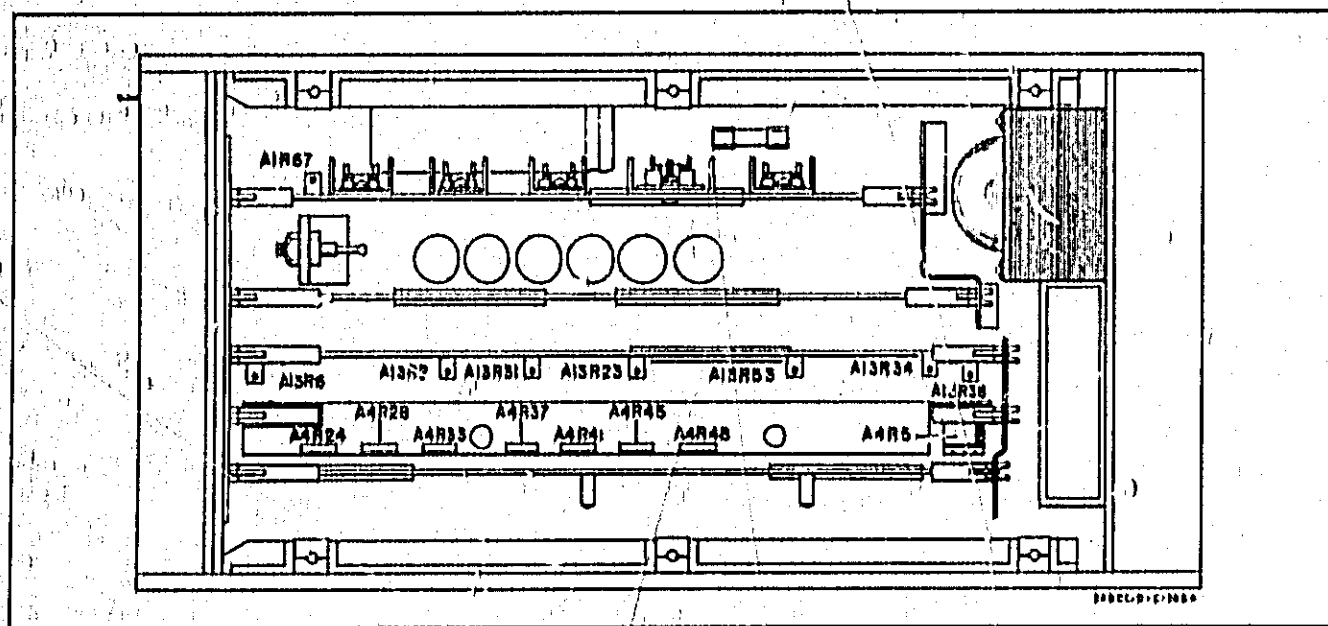

Figure 5-3. Location of Adjustments, Option 001 Instruments.

j. Connect a digital voltmeter having an input impedance greater than $10^8 \Omega$ and accuracy of 0.01 % or greater, between A13TP5 and the same ground point being used for input ground.

k. Apply input of +10,000 V from dc standard and adjust A13R2 for digital voltmeter reading (at A13TP5) of +10,000 V \pm 0.001 V. Disconnect digital voltmeter.

5-26. D/A CURRENT ADJUSTMENTS (Option 001).

5-27. A dc standard (hp- 740B) is required for these adjustments.

a. Connect positive side of dc standard output to A13TP8 (or Input High) and negative side to A13TP4 (or Input Low). Adjust standard output to +0.2005 V.

b. Adjust A4R48 to cause front panel display to alternate equally between +0.200 V and +0.201 V.

c. Set dc standard output to voltages shown in Table 5-10 and adjust control indicated to obtain proper display in each case.

Table 5-10. D/A Current Adjustments (Option 001).

DC Standard Output	Adjust Control	Alternating Display
+0.4005	A4R45	+0.400 V to +0.401 V
+0.8005	A4R41	+0.800 V to +0.801 V
+1.0005	A4R37	+1.000 V to +1.001 V
+2.0005	A4R33	+2.000 V to +2.001 V
+4.0005	A4R28	+4.000 V to +4.001 V
+8.0005	A4R24	+8.000 V to +8.001 V

5-28. INVERTING AMP GAIN ADJ (Option 001).

5-29. A dc standard (hp- 740B) is required for this adjustment.

a. With dc standard connected as in Paragraph 5-10 and display alternating between +8.000 V and +8.001 V, reverse polarity of standard output (-8.0005 V).

b. Adjust A13R34 to cause display to alternate between -8.000 V and -8.001 V. Disconnect dc standard.

5-30. SAMPLE/HOLD DELAY ADJUSTMENT (Option 001).

5-31. An oscilloscope (hp- 140A) is required for this adjustment.

a. Set rear panel SAMPLE/HOLD switch to ON, DELAY ON. Set SAMPLE RATE to maximum.

b. Connect oscilloscope sweep trigger input to Clock Control signal at lower end of A13L1. Set SWEEP TRIGGER to EXT + SLOPE, 10 μ s/cm.

c. Connect oscilloscope vertical input to A13TP3. Set vertical gain to 2 V/cm.

d. Waveform should be LOW (near zero) for 90 μ s \pm 2 μ s. If not, adjust A13R53 for the correct pulse width.

TROUBLESHOOTING

5-32. TROUBLESHOOTING.

5-33. The following procedures should be performed only after it has been determined that the malfunction cannot be corrected by the Adjustment Procedures, beginning in Paragraph 5-11. Included in the troubleshooting information are troubleshooting trees, waveforms, D/A circuit checks, amplifier checks and power supply checks. Instructions for replacing numerical display tubes and annunciator lamps are also included. Methods for determining proper values for factory selected components are given at the end of this section.

5-34. DISPLAY LED REPLACEMENT.

a. Remove the trim strip at the top front of the instrument.

b. Unscrew the LINE switch on the Model 3480D and push the switch back.

c. Lift the display window slightly to disengage it at the bottom and pull it forward. Also pull the window to the right slightly on the Model 3480D.

d. Replace the defective LED.

5-35. ANNUNCIATOR LED REPLACEMENT.

a. Pull off the annunciator tape assembly. (When replacing this assembly, it must be thoroughly pushed onto the LED's.)

b. Test the Ω thru AC annunciator LED's by grounding the six points 925 thru 927 at the lower right corner of the A7 Display Assembly. Ground the trace going to the H/H LED's to test these two. Use the bracket holding the diode between A1 and A2 as the ground.

c. Remove the five vertical printed-circuit assemblies and the sheet metal assembly mounting bracket behind the

Display Assembly. Two screws through each of the Master Board and Display assemblies hold the assembly mounting bracket.

d. Unsolder the defective LED and solder a new one in its place.

5-36. ACCESS TO BOTTOM OF MASTER BOARD AG.

a. Remove 3480C/D bottom cover by removing the flat head screws. It is not necessary to remove the plastic feet from the cover. Put the tilt stand on the 3480C will have to be removed by applying inward pressure on one side of the tilt stand.

b. Remove the nine screws holding the shield board to the master board.

c. Slide the shield board toward the rear of the instrument and lift out.

5-37. TROUBLESHOOTING TREES.

5-38. The troubleshooting trees at the end of this section are based upon certain display symptoms which may be encountered. They are designed to help determine whether the trouble is in the 3480C/D or the plug-in unit. The waveforms which precede the troubleshooting trees are referred to by number in the trees and in other troubleshooting information.

5-39. POWER SUPPLY CHECKS.

5-40. Notice in Figure 4-16 that there is considerable interdependence among the six power supply regulators, including two 30 V feedback loops. However, these two loops are automatically broken by six diodes if the ± 30 V drops; diodes CR63, CR41 and CR31 become back biased, and CR62, CR42 and CR32 supply raw voltages to the ± 10 V and ± 20 V regulators. This allows the trouble spot to be located at the first test point in the sequence that has the incorrect voltage. If there is uncertainty as to whether the regulator supplying the test point voltage is bad or is just being loaded down by the next regulator in sequence, then cut the jumper wire at the test point. Table 5-11 lists the voltage tolerance for each regulator.

5-41. GROUND CIRCUITS.

5-42. Excessive noise in the display may be caused by a shorted diode between the low current ground circuit and high current ground. Check AGCR7 and 8, shown in Figure 7-24.

Table 5-11. Power Supply Voltages.

Measurement Point	Voltage
A1TP4	+10,000 V \pm 0,0002 V
TP1	+20 V \pm 0,04 V
TF7	+30 V \pm 0,41 V
TP6	+5 V \pm 0,1 V
TP8	-30 V \pm 0,45 V
TP5	-20 V \pm 0,08 V

5-43. The display LED's are powered by a ± 5 V supply on the A1 assembly.

5-44. AMPLIFIER TROUBLESHOOTING.

5-45. The Polarity Amplifiers, Comparator Amplifier, and ± 10 V Regulator are all very similar and the same general troubleshooting procedures apply to each. First, check voltages at various points within the amplifier in question as noted on the schematic diagram and under the conditions noted. Conditions are different for each amplifier.

5-46. If the voltages at the collectors of the dual transistors are not equal, measure the voltage at the emitter of the constant current source transistor in the emitter circuit of the dual transistor. If the voltage drop across the emitter resistor of the constant current source is greater than about 2 V, one side of the dual transistor may be open.

5-47. Non-Inverting Polarity Amplifier Gain Check.

a. Set RANGE and FUNCTION to 10 Vdc.

b. Connect a floating dc voltmeter voltage probe to A3TP3, common lead to A3TP4. Set dc voltmeter to 1 mV range, negative polarity.

c. Connect dc standard to INPUT and set standard output to -9,900 V.

d. Note dc voltmeter reading. Should be about 0.7 mV.

e. Using a clip lead, short A3TP3 to A3TP5 and note change in dc voltmeter reading. Amount of change should be between 0,014 mV and 0,070 mV. Loop gain of the amplifier may be determined using the following formula:

$$\text{Gain} = \frac{0.7}{\text{Change in voltage (in volts)}}$$

Minimum allowable gain is 10,000. If gain is low (voltage changes more than 0,070 mV) check amplifier transistors A3Q3 - 6 for low gain characteristics.

5-48. Inverting Polarity Amplifier Gain Check.

a. Set RANGE and FUNCTION to 10 Vdc.

b. Construct a 2:1 divider using two 100 kilohm resistors having a tolerance of $\pm 0,02$ % or better. (Jhp- Part No. 0811-0354 is 100 kilohm $\pm 0,01$ %.) If precision resistors are not available, resistors having greater tolerance may be used if they are resistance matched to within $\pm 0,04$ %.

c. Connect the 2:1 divider between A3TP3 and A3TP4.

d. Connect a floating dc voltmeter between the center tap of the divider and LOW input terminal or A3TP2.

e. Connect dc standard to INPUT. Adjust standard output to +9.900 V.

f. Note dc voltmeter reading. Should be about 0.7 mV.

g. Using a clip lead, short A3TP3 to A3TP6 and note change in dc voltmeter reading. Amount of change should be between 0.010 mV and 0.070 mV. Loop gain of the amplifier may be determined using the formula given in Paragraph 5-62. Minimum allowable gain is 10,000. If gain is low (voltage changes more than 0.070 mV) check amplifier transistors A3Q10-13 for low gain characteristics.

5-49. Comparator Amplifier Gain Check.

a. Short INPUT and set SAMPLE RATE to HOLD.

b. Connect a dc differential voltmeter between A4Q6 collector and ground (input LOW). Note and record differential voltmeter reading to four decimal places.

c. Connect a 10 kilohm resistor between A4Q6 collector and ground and note change in differential voltmeter reading. If reading changes more than 0.6 mV, check amplifier transistors A4Q3-6 for low gain characteristics.

5-50. +10 V Regulator Gain Check.

a. Connect a dc differential voltmeter between A1TP4 and ground (input LOW). Note and record reading to four decimal places.

b. Connect a 10 kilohm resistor between A1TP4 and ground and note change in differential voltmeter reading. If reading changes more than 0.8 mV, check A1 IC61, IC62 for low gain characteristics.

5-51. MEMORY LOGIC AND D/A SWITCH CHECK.

5-52. Certain display symptoms may indicate the type of failure in the D/A switches. For example, if the input voltage is 8.1 V and the display is 7.999, the 4000 D/A switch may be staying on all the time. In this case, the 8000 bit would be rejected, since 8000 plus 4000 is greater than the input voltage. The 3000, 2000 and 1000 bits would then be retained. The remaining digits would then indicate 9, since the remaining voltage difference is greater than .999. This "series of 9's" symptom may also follow a malfunction in the hundreds or tens digit bits in the same manner. A similar symptom may result if the 18-pulse counter counts more than two but less than 18 pulses. In this case all the D/A memory flip-flops may be set to true, resulting in a "999" display, or to false, resulting in a "000" display.

5-53. If certain numbers fail to appear in the thousands, hundreds, tens or units display, one of the Memory Logic Circuits or D/A Switches for that digit may be inoperative. For example, if the "1" Logic Circuit for the thousands digit were inoperative, that digit might display even numbers only. The following checks will help detect a defective circuit.

a. Set plug-in unit RANGE and FUNCTION to 10 Vdc. Set SAMPLE RATE control fully clockwise.

b. Connect dc standard to input. Set standard output to +0.1 V. If a number other than zero appears in the thousands digit, the Memory Logic Circuit or D/A switch associated with that number is probably defective.

c. Change standard output to +1.1 V. Number 1 should light in thousands digit. Increase input voltage in 1 V steps and observe thousands digit display to see if numbers appear in proper sequence. If sequence is incorrect, check circuits indicated under Thousands column in Table 5-1.2.

d. Check hundreds digit by reducing the input voltage by a factor of 10 and repeating the procedure in steps b and c. Check tens and units digits in the same manner, reducing the input voltage proportionately.

e. If the same erroneous sequence appears in all four digits, trouble is probably in the Counter Decoding Logic. For example, if the "4" circuits fail to operate, the C enabling circuit A2Q5 is probably defective.

f. If one of the digits displays only zero, check the Counter Decoding Logic circuit which enables that digit. For example, if the tens digit stays on zero, check the 10 enabling circuit, A2Q10. If this circuit operates properly, check the storage and decoding integrated circuits.

5-54. Memory Logic Circuit Check.

5-55. The A2 Component Location drawing in Figure 7-5 identifies the Memory Logic IC's according to numerical function. In most cases, an IC that is suspected of being defective may be checked most readily by substitution. If a spare IC is not available, the following procedure may be used.

a. Short INPUT and set SAMPLE RATE to HOLD.

b. If display is not 0000, a momentary ground contact at pin 1 or 13 of the IC for any number appearing in the display should return the display to zero. If the number is removed from the display while pin 1 or 13 is grounded, but returns when the ground connection is removed, the IC is probably defective. If the number remains in the display during the time pin 1 or 13 is grounded, the IC may be defective or the trouble may be in the associated D/A switch circuit.

Table 5-12. Memory Logic and D/A Switch Check.

If numbers light in sequence (below) (Input = 0 1 2 3 4 5 6 7 8 9)	D/A Switch Remains	Troubleshoot the following circuit:			
		Thousands Digit	Hundreds Digit	Tens Digit	Units Digit
1 1 1 0 3 5 5 7 7 0 0 0 2 2 4 4 6 6 8 0	ON OFF	A4Q17 - 10	A4Q27	A4Q31	A4Q35
2 2 2 3 3 3 6 7 7 7 0 1 1 1 4 5 5 5 8 0	ON OFF	A4Q14 - 16	A4Q26	A4Q31	A4Q34
4 4 4 4 4 5 6 7 7 7 0 1 2 3 3 3 3 3 8 0	ON OFF	A4Q11 - 13	A4Q23 - 25	A4Q20	A4Q33
8 8 8 8 8 8 8 8 8 0 0 1 2 3 4 5 6 7 7 7	ON OFF	A4Q8 - 10	A4Q20 - 22	A4Q28	A4Q32

* Numbers appearing to the right of digit being tested are functional.

c. A momentary connection from pin 14 to pin 3 or 11 via a 2 k Ω resistor on any of the Memory Logic IC's should cause the corresponding number to appear and remain in the display. If the number appears during the connection but does not remain after the connection is removed, the IC is probably defective. If the number does not appear when the connection is made, the trouble is probably in the associated D/A Switch circuit, or A2IC5, IC10, IC15 or IC19.

5-56. D/A Switch Check.

5-57. Table 5-13 lists normal voltages at bases of D/A Switch transistors. The "1" state is the state which causes the number to appear in the display.

Table 5-13. D/A Switch Voltages.

Transistor Base	"1" State	"0" State
A4Q8, 11, 16, 10, 22, 25	+1.70 V	+0.6 V
A4Q10, 13, 14, 17, 20, 23	+10.0 V	+1.16 V
A4Q26 - 35	+0.16 V	+2.4 V

5-58. SAMPLE/HOLD AMPLIFIER CHECKS (Option 001).

5-59. The Sample/Hold Amplifier circuits may be checked by measuring the dc voltages at various points within the amplifier. Voltage measurements should be within $\pm 10\%$ of the voltages shown on the schematic diagram, which were measured with a ± 10 V input to the Sample/Hold Amplifier.

5-60. SAMPLE/HOLD POLARITY AMP CHECKS (Option 001).

5-61. The integrated circuit Polarity Amplifiers may also be checked by voltage measurements. Voltages at pin 2 and 3 of either amplifier should be near zero and equal within a

few millivolts. The Sample/Hold Amplifier Assembly output at A13TP10 should be ± 10 V for an input of either $+$ or $- 10$ V.

5-62. SAMPLE/HOLD LOGIC CHECKS (Option 001).

5-63. The logic waveforms observed with an oscilloscope at the points indicated on the schematic diagram should be similar to those shown. Figure 4-17 shows the logic timing sequence. Voltage levels in the logic circuits should also be checked. A LOW state must be 0 to $+0.5$ V, and a HIGH state must be $+2.4$ V to $+5$ V.

5-64. ISOLATED BCD OUTPUT (Option 004).

5-65. The coupling between inboard and outboard circuits is done optically with photo-isolators. Each isolator is driven by a four-bit parallel-to-serial multiplexer; the isolator then drives a four-bit shift register. (See the Binary Counter Signals on Page 7-19.) If the isolator turns off too slowly, the shift register may see the trailing edge of a former bit and give a false output bit. A low efficiency isolator will cause the bit to be skipped.

5-66. To check the timing of a light isolator, trigger an oscilloscope at TP3 (Clock) and check the signals shown in the Units Shift Register Input figure on Page 7-19. Observe the time relationship between the Clock and data signals at IC25 pins 9 and 1. The data must be present when a Clock high-to-low transition occurs.

5-67. FACTORY SELECTED COMPONENTS.

5-68. Certain component values are factory selected for proper operation of a particular circuit. Normally, these values need not be changed unless the replacement of an associated component changes the circuit parameters. Factory selected components are designated on the schematic diagram by an asterisk (*) and their average value is shown. The following paragraphs explain the procedures for selecting these component values.

5-60. A1R60.

5-70. The value of this resistor is factory selected to bring A1R67 within the proper range. It should not be necessary to change this resistor unless A1CR61 has been replaced and the +10 V regulated voltage cannot be adjusted to the correct value in Paragraph 5-14. If A1R67 has insufficient range of adjustment, return the A1 assembly to the factory for re-selection of these resistors. Contact your nearest Ship Sales and Service Office (See Appendix A).

5-71. A3R2 and A3R3.

5-72. These resistors are in the emitter circuit of A3Q1A, B and determine the range of the NEG AMP ZERO control A3R4. If A3Q1 has been replaced and the amplifier zero adjustment cannot be made in Paragraph 5-18, but the amplifier appears to be operating normally in other respects the following procedure may be used to determine the proper resistor values of A3R2 and A3R3. These resistors are 1% 1/8 W metal film resistors.

a. If the shorting jumper in parallel with either resistor has been cut, replace this shorting wire.

b. Connect a dc standard to INPUT or to A3TP4 (see explanation in Paragraph 5-15). Set standard output to -0.0090 V.

c. Connect a dc voltmeter having a full-scale range of 10 mV between A3TP3 and ground.

d. Observe dc voltmeter reading while adjusting NEG AMP ZERO control A3R4 from one extreme to the other. Range of voltage reading should be from about -8.5 mV to -9.5 mV.

e. If voltmeter reading goes too far positive (less than -8.5 mV), remove the jumper across A3R2. If this is not sufficient, replace A3R2 with a 619 Ω resistor, Ship Part No. 0757-0418.

f. If voltmeter reading goes too far negative, remove the jumper across A3R3. If this is not sufficient, replace A3R3 with a 619 Ω resistor, Ship Part No. 0757-0418.

g. Perform Amplifier Zero Adjustments, Paragraph 5-18.

5-73. A3R17 and A3R19.

5-74. These resistors in the emitter circuit of A3Q8A, B determine the range of the POS AMP ZERO control A3R18. If A3Q8 has been replaced and the amplifier zero adjustment cannot be made in Paragraph 5-18, but the amplifier appears to be operating normally in other

respects, the following procedure may be used to determine the proper resistance of A3R17 and A3R19. These resistors are 1% 1/8 W metal film resistors.

a. If the shorting jumper in parallel with either resistor has been cut, replace this shorting wire.

b. Connect a dc standard to INPUT or A3TP4 (see explanation in Paragraph 5-15). Set standard output to +0.0090 V.

c. Connect a dc voltmeter having a full-scale range of 10 mV between A3TP3 and ground.

d. Observe dc voltmeter reading while adjusting POS AMP ZERO control A3R18 from one extreme to the other. Range of voltage reading should be from about +8.5 mV to +9.5 mV.

e. If voltmeter reading goes too far negative, remove the jumper across A3R17. If this is not sufficient, replace A3R17 with a 464 Ω resistor, Ship Part No. 0698-0082.

f. If voltmeter reading goes too far positive (less than +8.5 mV), remove jumper across A3R19. If this is not sufficient, replace A3R19 with a 464 Ω resistor, Ship Part No. 0698-0082.

g. Perform Amplifier Zero Adjustments, Paragraph 5-18.

5-75. A4R4 and A4R6.

5-76. These resistors in the emitter circuit of A4Q1A, B determine the range of the COMP ZERO control, A4R5. If A4Q1 has been replaced and the comparator zero adjustment cannot be made in Paragraph 5-18, but the comparator amplifier appears to be operating normally in other respects, the following procedure may be used to determine the proper value of A4R4 and A4R6. These resistors are 1% 1/8 W metal film resistors.

a. If the shorting jumper in parallel with either A4R4 or A4R6 has been cut, replace this jumper.

b. Perform the Amplifier Zero Adjustments in Paragraph 5-18 through step e.

c. If the display in Paragraph 5-18 step e will not alternate equally between -0.000 and +0.001, but remains on -0.000 even when A4R5 is completely counterclockwise, remove jumper across A4R4.

d. If the display remains too far negative and will not reach +0.000, remove jumper across A4R6.

e. Complete the Adjustment and Calibration Procedures in Paragraph 5-18.

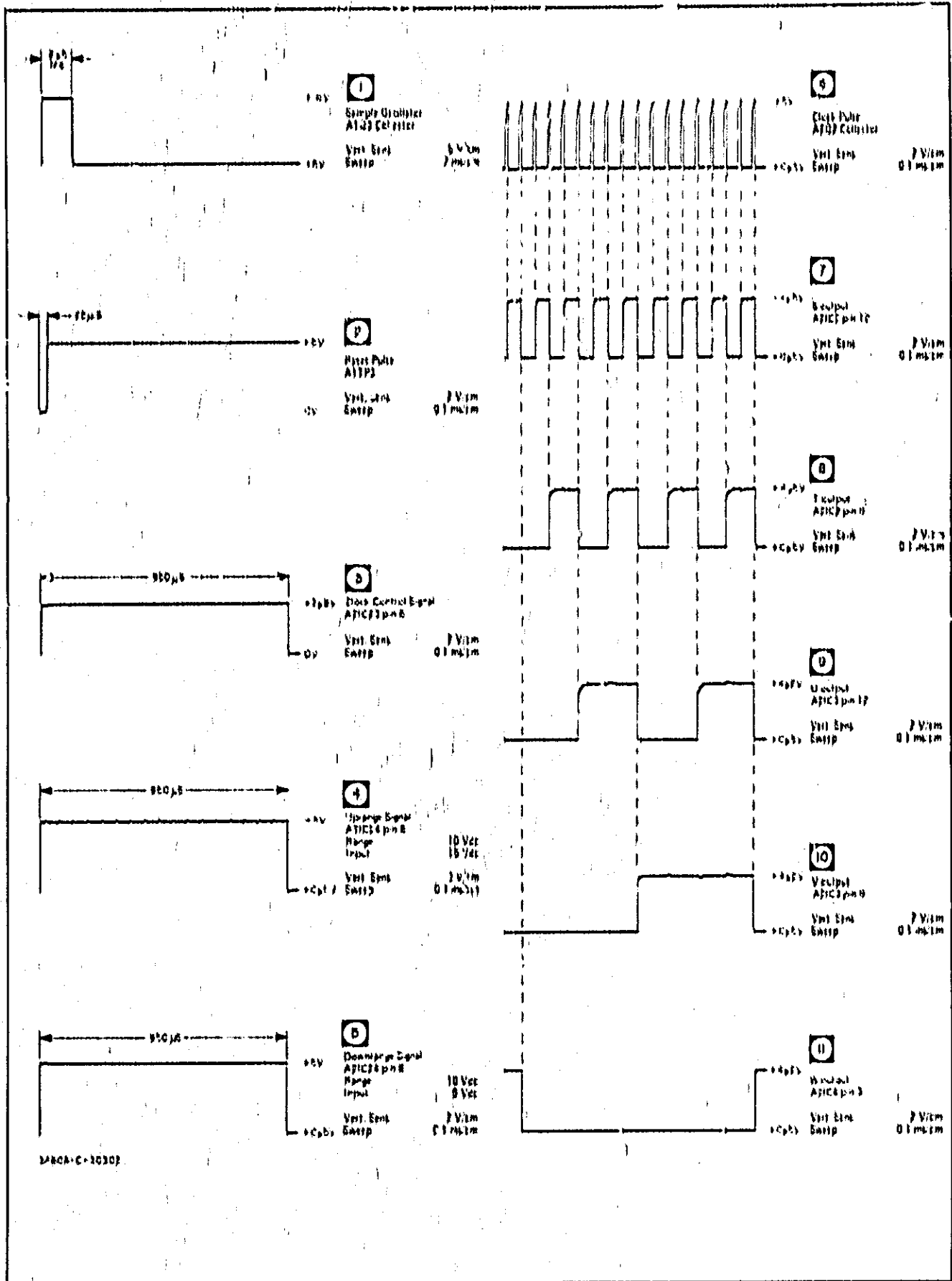

Figure 5-4a. Waveforms.

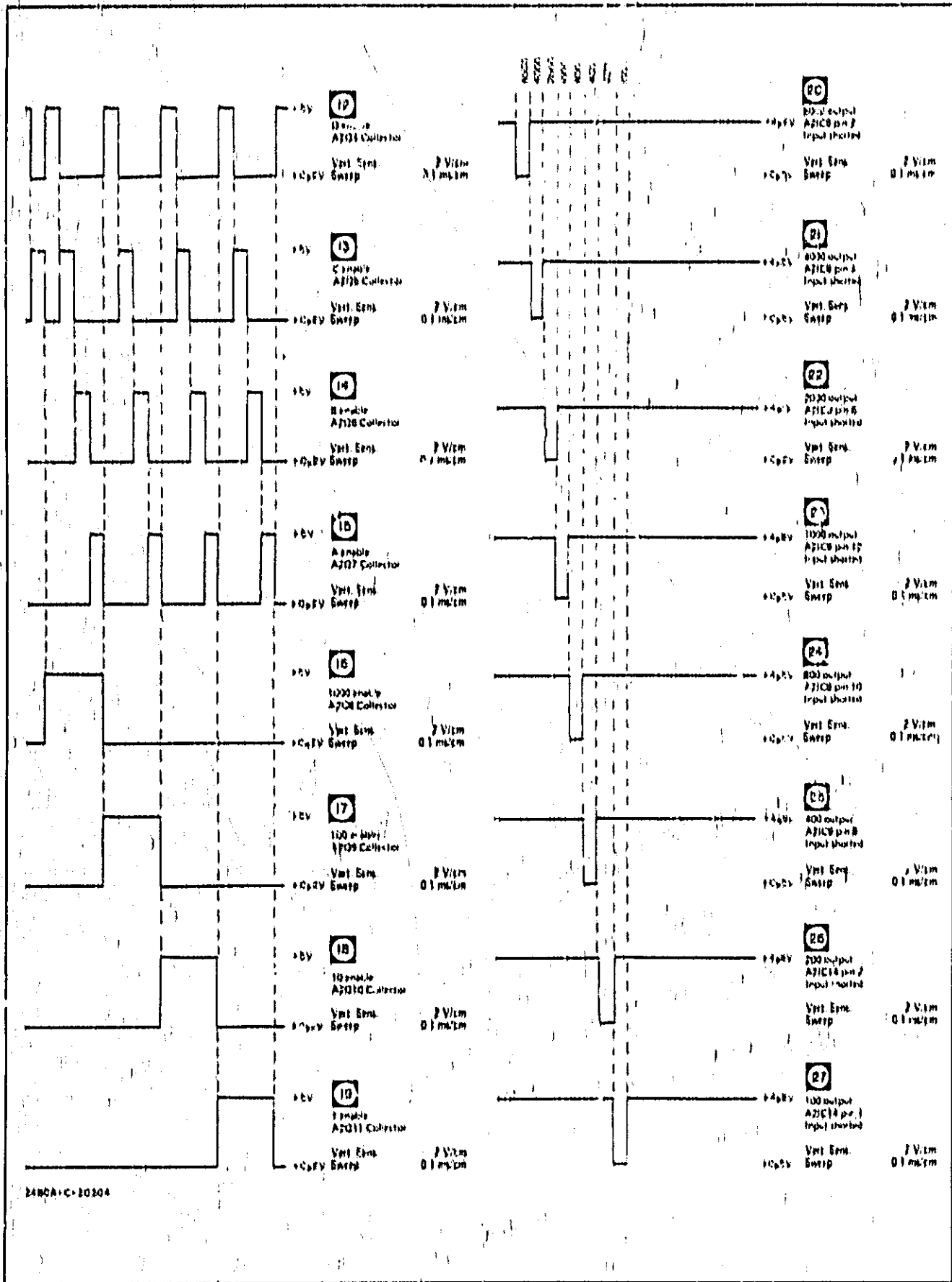

Figure 5-4b. Waveforms.

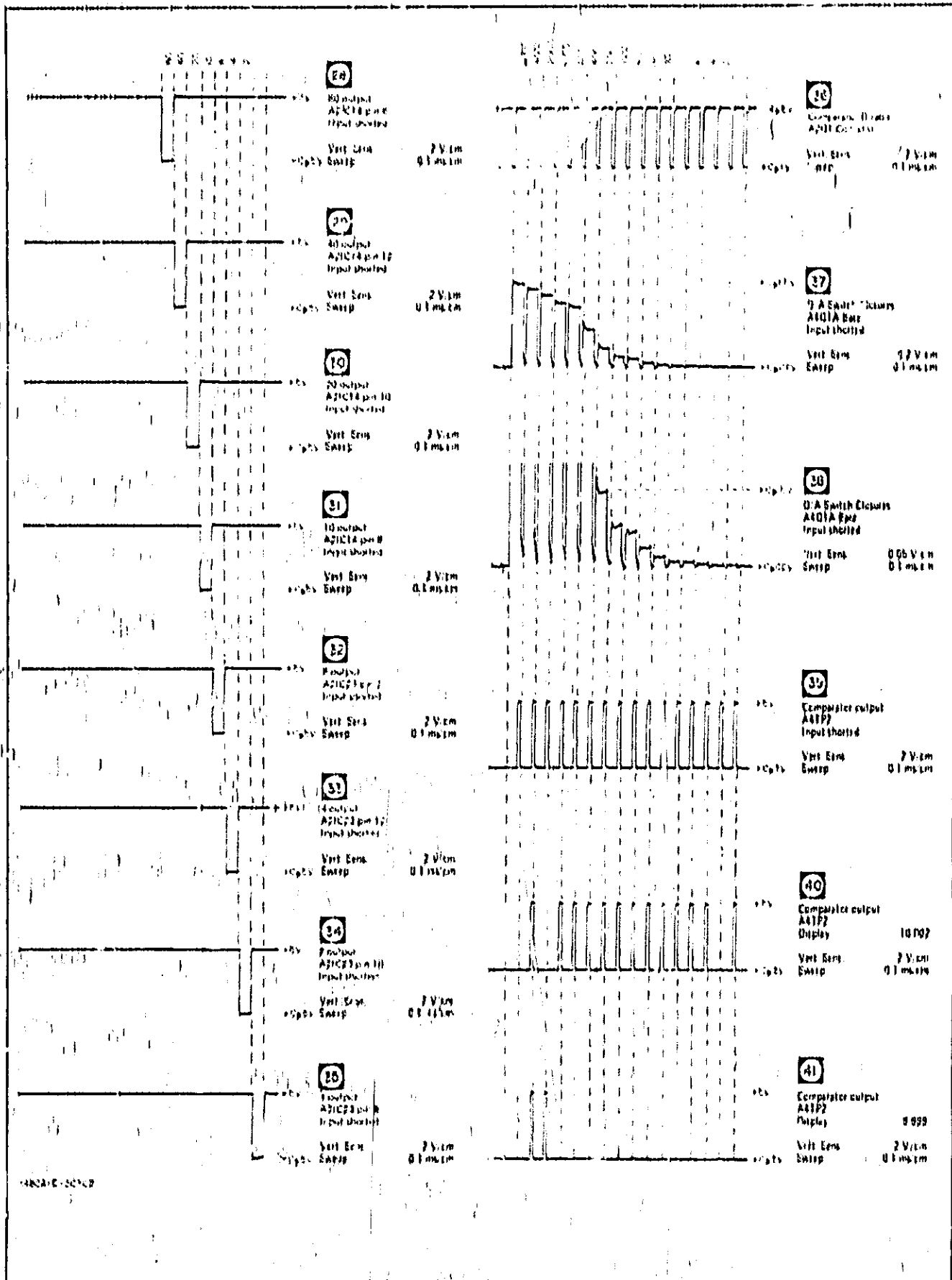

Figure 5-4c. Waveforms.

Troubleshooting Tree A.

1. If Reset pulse is correct, Sample Oscillator and Reset Amplifier are operating properly.
2. Pulse at A2TP1 should be nearly identical to Reset pulse at A1TP3. Delay in leading edge is only 2 microseconds.
3. If pulse is present, pulse rate should be variable with SAMPLE RATE control.
4. Waveform should be series of 18 negative-going pulses. More or fewer pulses indicate incorrect operation of Clock Multivibrator or associated circuits.
5. Signal path is through J1(F), J2H(10), and A2L1.
6. If Sample Oscillator operating but Reset pulse is not present, check A1C8 and A1C82.
7. A voltage of about +10 V or greater at A1Q86 collector will cause the Sample Oscillator to stop operating.
8. In normal operation, 18th clock pulse causes 18-pulse counter to change the state of the Clock Control Flip-Flop and stop the Clock Multivibrator. If Multivibrator operates continuously, trouble may be in the 18-Pulse Counter. Waveforms 6 thru 11 show correct outputs. If counter waveforms appear to be correct, trouble may be in the Clock Control Flip-Flop or Clock Switch.
9. If Reset pulse is present, but Clock Multivibrator is not operating, check Clock Control signal at A2IC23 pin 6 (Waveform 3). Positive portion of Waveform 3 should be +3.5 V or greater to turn off A2Q3 and allow Clock Multivibrator to free-run. If waveform is present but level is too low, it is possible that excessive loading of the Clock Control signal occurs elsewhere in the 3480C/D or plug-in.
10. Voltage at A1TP2 is supplied by SAMPLE RATE control.
11. If Interface Hold and Printer Holdoff lines are open, A1Q86 collector should be near zero.
12. A1Q81-Q83, A1CR81, CR82, or A1C81 may be defective.
13. Check for broken wire to SAMPLE RATE control or P12 in plug-in, or from J12 to A6 in 3480C/D.

NOTES:

1. All voltage and waveform measurements referenced to input LOW (black) terminal.
2. If SAMPLE RATE indicator does not light, check lamp before proceeding with troubleshooting tree.
3. Waveforms appear in Figure 5-4, b, c.

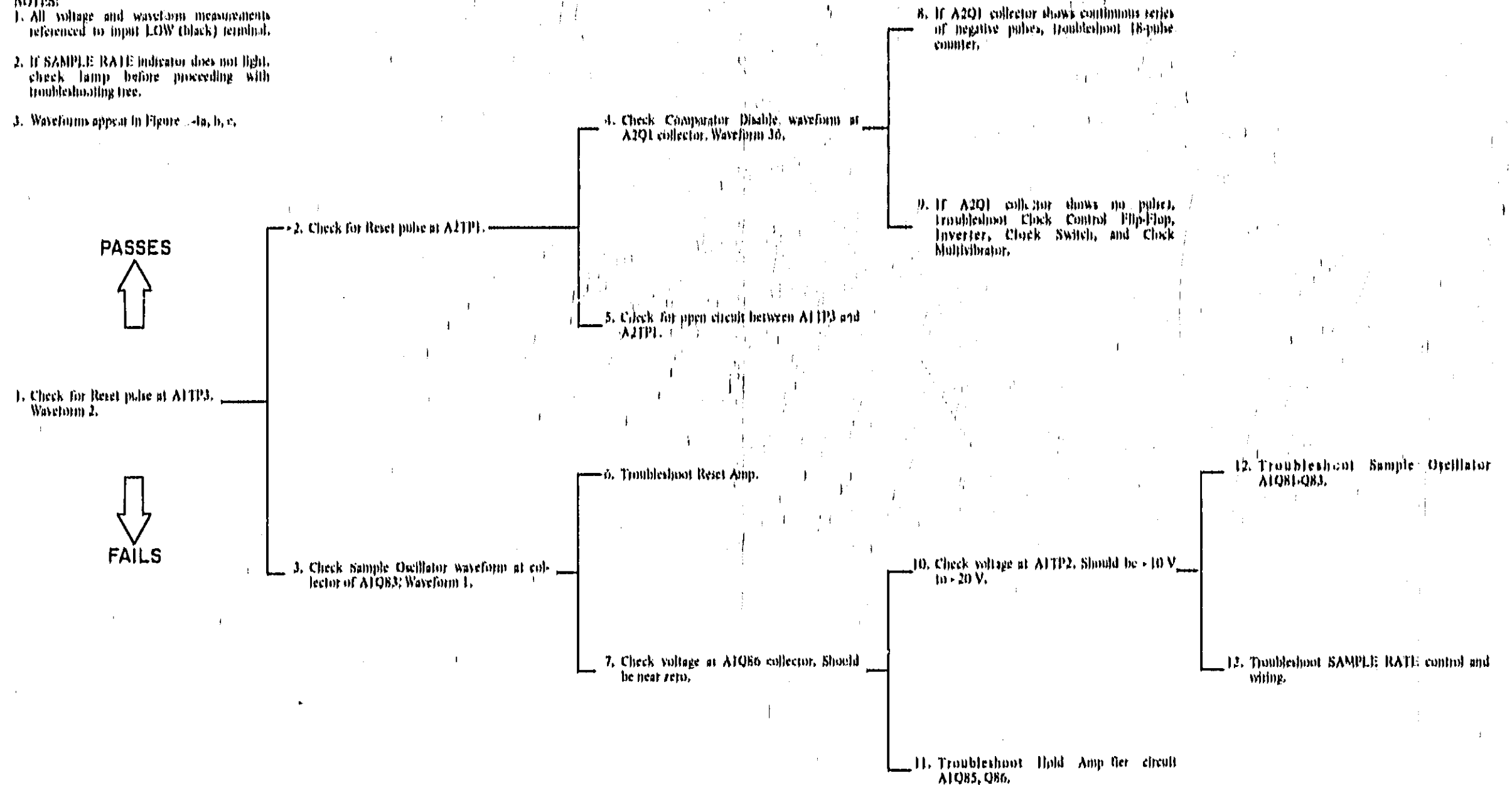

SYMPTOMS:
 Instrument does not sample (SAMPLE RATE fully CW).
 Steady random display not related to input.
 SAMPLE RATE indicator does not flash.

Figure 5-5. Troubleshooting Tree A.
 5-15/5-16

Troubleshooting Tree B.

1. Voltage at A3TP4 should be same as input voltage.
2. With 10.000 V input, Comparator output should reject all except 8000 and 2000 comparisons.
3. If voltage at A3TP4 is not correct, trouble is in plug-in or interconnections.
4. If Comparator output waveform is correct, trouble may be in storage or decoder circuits.
5. If 16 Comparator output pulses are present, Polarity Amplifier may be at fault. See Paragraph 5-45.
6. If Comparator output voltage at A4TP2 remains at a level of about +1.5 V or higher, trouble is probably in Comparator Amplifier. See Paragraph 5-45.
7. If voltage at buffer amplifier output is correct but voltage at A3TP4 is not, interconnection must be faulty.
8. Refer to plug-in Operating and Service Manual for troubleshooting information.
9. If 16 Comparator output pulses are present and voltage at A3TP3 is correct, A4R1 may be open.
10. Positive input voltage checks Inverting Amplifier; negative input checks Non-Inverting Amplifier.
11. If voltage is correct with negative input but incorrect with positive input, Inverting Amplifier is at fault. See Paragraph 5-45.
12. If voltage at A3TP4 is correct but voltage at A3TP3 is not correct with either polarity input, diodes A3CR4 and A3CR8 may be open, or amplifier output may be shorted.

NOTES:
 1. All voltage and waveform measurements referenced to Input LOW (black) terminal.
 2. Waveforms appear in Figure 5-4a, b, c.

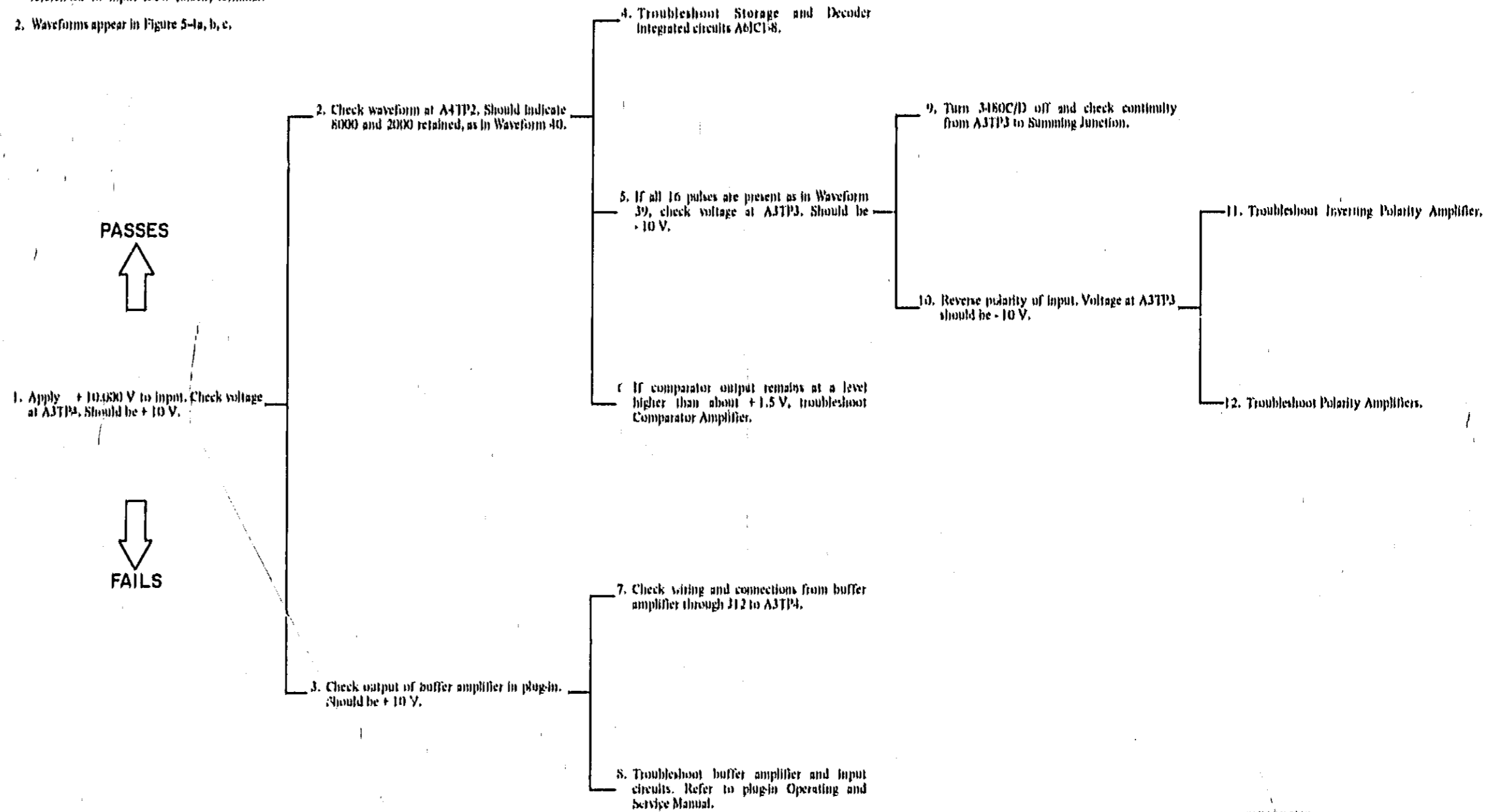

3460A-C-20288

SYMPTOMS:
 Numerical display is 0000 regardless of input voltage. Sample indicator flashes normally.

Figure 5-6. Troubleshooting Tree B.
 5-17/5-18

Troubleshooting Tree C.

1. When Input is shorted, output of Polarity Amplifiers should be zero. This check determines if trouble is in analog amplifiers or digital circuits.
2. In normal operation, Comparator output should be series of 16 pulses when input is zero. If 18 pulses appear, Comparator Zero control may not be properly adjusted. See Paragraph 5-18.
3. If voltage at A3TP3 is not zero, check voltage at A3TP4 to determine if trouble is in 3480C/D or plug-in.
4. With input shorted, Comparator output pulses should reset all Memory Logic circuits to "0" state. If A2CR24 were open, for example, the Thousands Memory Logic circuits would remain on, resulting in an OVERLOAD display.
5. The positive "steps" of Waveforms 37 and 38 at the Summing Junction indicate that all 16 D/A Switches are being turned on in sequence.
6. If voltage at A3TP4 is correct but voltage at A3TP3 is not, trouble is in Polarity Amplifiers. Refer to Paragraph 5-50.
7. Refer to plug-in Operating and Service Manual for troubleshooting information.
8. If input to Comparator is correct but no output pulses are present, A4Q7 may be shorted.
9. If Summing Junction remains LOW, A4CR1 or CR2 may be shorted.

- NOTES:
1. Check Power Supplies before proceeding with this troubleshooting tree. See Paragraph 5-54.
 2. All voltage and waveform measurements referenced to input LOW (black) terminal.
 3. Waveforms appear in Figure 5-4a, b, c.

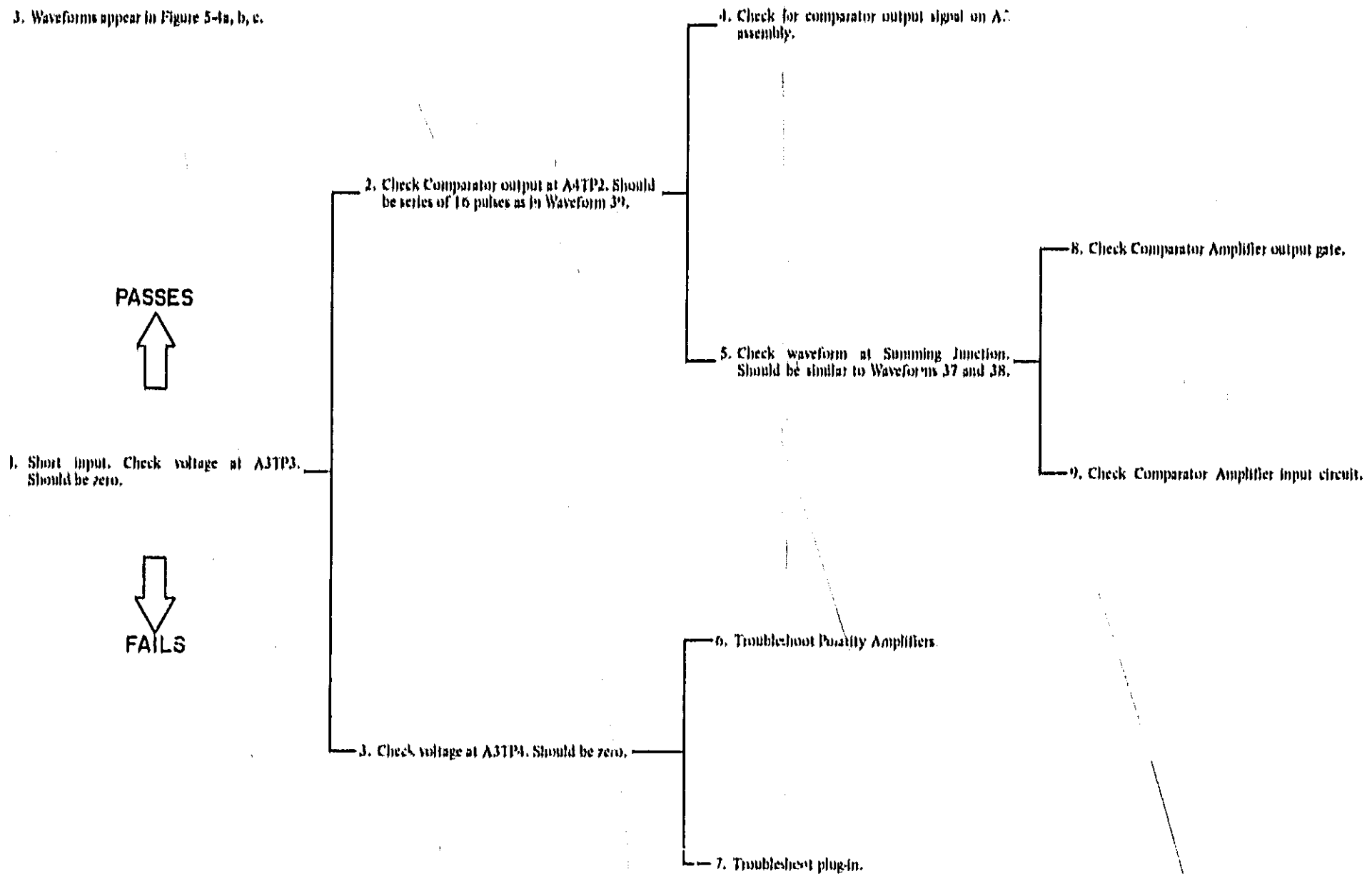

3480A-C-20367

SYMPTOMS:
 Display reads OVERLOAD regardless of input voltage.
 SAMPLE RATE indicator flashes normally.

Figure 5-7. Troubleshooting Tree C.
 5-19/5-20

PERFORMANCE CHECK

PERFORMANCE CHECK CARD

Hewlett-Packard Model 3480C/D
 Digital Voltmeter
 Serial No. _____

Tests performed by _____
 Date _____

Paragraph	Description	Reading		Test Limits
		Pos.	Neg.	
5-7	Sample/Hold Check (Option 001)			
	Step b	_____	_____	± 9.998 V to 10.002 V
	Step c	_____	_____	± 9.998 V to 10.002 V
	Step d	_____	_____	± 0.999 V to 1.001 V
	Step g	_____	_____	± 9.998 V to 10.002 V
5-9	BCD Output Check (Option 003, 004)	OK	_____	

PARTS LIST

SECTION VI REPLACEABLE PARTS

6-1. INTRODUCTION.

6-2. This section contains information for ordering replacement parts. Table 6-1 lists parts in alphabetic order of their reference designators and indicates the description, hp-part number of each part, together with any applicable notes, and provides the following:

- a. Description of the part. (See list of abbreviations below.)
- b. Typical manufacturer of the part in a five-digit code. (See Appendix A for list of manufacturers.)
- c. Manufacturer's part number.

6-3. Miscellaneous parts are listed at the end of Table 6-1.

6-4. ORDERING INFORMATION.

6-5. To obtain replacement parts, address order or inquiry to your local Hewlett-Packard Field Office. (See Appendix B for list of office locations.) Identify parts by their Hewlett-Packard part numbers. Include instrument model and serial numbers.

6-6. NON-LISTED PARTS.

6-7. To obtain a part that is not listed, include:

- a. Instrument model number.
- b. Instrument serial number.
- c. Description of the part.
- d. Function and location of the part.

ABBREVIATIONS																									
<p>Ag silver Al aluminum A ampere(s) Au gold</p> <p>C capacitor CMT ceramic CMT coefficient COM common COMP component CONN connection</p> <p>DEP deposited DPDT double pole double throw DPST double pole single throw</p> <p>ELECT electrolytic ENCAP encapsulated</p> <p>F ferrite FET field effect transistor FIL filament</p> <p>GAAs gallium arsenide GHz gigahertz = 10⁹ hertz G gauss(es) Ge germanium GND grounded</p> <p>H henry(ies) Hg mercury</p>	<p>M mega ID inside diameter IMP impregnated INS insulation K kilohm(s) = 10³ ohms KHz kilohertz = 10³ hertz</p> <p>L inductor LIT linear taper LOG logarithmic taper</p> <p>MA milliamperes = 10⁻³ amperes MHz megahertz = 10⁶ hertz MΩ megohm(s) = 10⁶ ohms MFL metal film MFR manufacturer MIL mil MIL millivolt(s) = 10⁻³ volts MFR microfarad(s) MFR microsecond(s) MFR microvolt(s) = 10⁻⁶ volts MY Mylar</p> <p>NA nanoampere(s) = 10⁻⁹ amperes NC normally closed NE neon NO normally open</p>																								
DECIMAL MULTIPLIERS																									
<table border="1" style="width: 100%; border-collapse: collapse;"> <thead> <tr> <th>Prefix</th> <th>Symbol</th> <th>Multiplic</th> </tr> </thead> <tbody> <tr> <td>tera</td> <td>T</td> <td>10¹²</td> </tr> <tr> <td>giga</td> <td>G</td> <td>10⁹</td> </tr> <tr> <td>mega</td> <td>M or Meg</td> <td>10⁶</td> </tr> <tr> <td>kilo</td> <td>K or k</td> <td>10³</td> </tr> <tr> <td>hecto</td> <td>h</td> <td>10²</td> </tr> <tr> <td>deka</td> <td>da</td> <td>10</td> </tr> <tr> <td>deci</td> <td>d</td> <td>10⁻¹</td> </tr> </tbody> </table>	Prefix	Symbol	Multiplic	tera	T	10 ¹²	giga	G	10 ⁹	mega	M or Meg	10 ⁶	kilo	K or k	10 ³	hecto	h	10 ²	deka	da	10	deci	d	10 ⁻¹	<p>NPD negative positive zero (zero temperature coefficient) NS nanosecond(s) = 10⁻⁹ seconds NR not repairable/replaceable</p> <p>O ohm(s) OBD order by description OD outside diameter</p> <p>P peak pA picoampere(s) PC printed circuit pF picofarad(s) = 10⁻¹² farads P peak-to-peak voltage P part of POS position(s) POL polystyrene PP polystyrene PPM parts per million PTC precision temperature coefficient, long term stability and/or tolerance</p> <p>R resistor RH rhodium RMS root mean square ROT rotary</p> <p>Se selenium S section(s) Si silicon</p>
Prefix	Symbol	Multiplic																							
tera	T	10 ¹²																							
giga	G	10 ⁹																							
mega	M or Meg	10 ⁶																							
kilo	K or k	10 ³																							
hecto	h	10 ²																							
deka	da	10																							
deci	d	10 ⁻¹																							
DESIGNATORS																									
<p>A assembly B motor BT battery C capacitor CR diode DL delay line DS lamp E mic electronic part F fuse</p> <p>FL filter HR heater IC integrated circuit J jack K relay L inductor M meter MP mechanical part P plug</p>	<p>Q transistor OCR transistor diode R resistor RT thermistor S switch T transformer TB terminal board TC thermocouple TP test point</p> <p>TS terminal strip U microcircuit V vacuum tube, neon bulb, photodiode, etc. W cable X socket XDS transformer ZF transformer Y crystal Z pinwheel</p>																								

STD 8 273A

Table 6-1. Replaceable Parts

Reference Designation	HP Part Number	Description	Mfr Code	Mfr Part Number
A1	0340-2682	POWER SUPPLY ASBY	28480	0340-2682
A1C11	0160-0538	CAPACITOR, FAD, 000100-01 100WVDC	28480	0160-0538
A1C71	0160-0172	CAPACITOR, FAD, 000200-01 100WVDC	28480	0160-0172
A1C22	0160-2604	CAPACITOR, FAD, 000100-01 100WVDC	28480	0160-2604
A1C31	0160-0206	CAPACITOR, FAD, 000100-01 100WVDC	28480	0160-0206
A1C41	0160-0050	CAPACITOR, FAD, 000100-01 100WVDC	28480	0160-0050
A1C51	0160-0050	CAPACITOR, FAD, 000100-01 100WVDC	28480	0160-0050
A1C61	0160-2195	CAPACITOR, FAD, 000100-01 100WVDC	28480	0160-2195
A1C12	0160-2195	CAPACITOR, FAD, 000100-01 100WVDC	28480	0160-2195
A1C63	0160-3188	CAPACITOR, FAD, 000100-01 100WVDC	28480	0160-3188
A1C81	0160-3188	CAPACITOR, FAD, 000100-01 100WVDC	28480	0160-3188
A1C82	0160-0188	CAPACITOR, FAD, 000100-01 100WVDC	28480	0160-0188
A1C83	0160-2208	CAPACITOR, FAD, 000100-01 100WVDC	28480	0160-2208
A1C84	0160-0188	CAPACITOR, FAD, 000100-01 100WVDC	28480	0160-0188
A1C85	0160-0188	CAPACITOR, FAD, 000100-01 100WVDC	28480	0160-0188
A1C812	1501-0040	DIODE, SWITCHING, 5I, 30V MAX VRM 20MA	28480	1501-0040
A1C814	1501-0040	DIODE, SWITCHING, 5I, 30V MAX VRM 20MA	28480	1501-0040
A1C822	1501-0040	DIODE, SWITCHING, 5I, 30V MAX VRM 20MA	28480	1501-0040
A1C824	1501-0040	DIODE, SWITCHING, 5I, 30V MAX VRM 20MA	28480	1501-0040
A1C831	1501-0040	DIODE, SWITCHING, 5I, 30V MAX VRM 20MA	28480	1501-0040
A1C832	1501-0040	DIODE, SWITCHING, 5I, 30V MAX VRM 20MA	28480	1501-0040
A1C833	1502-0766	DIODE, VREG, 18.2V VZ, 5W MAX	28480	1502-0766
A1C834	1501-0040	DIODE, SWITCHING, 5I, 30V MAX VRM 20MA	28480	1501-0040
A1C835	1501-0040	DIODE, SWITCHING, 5I, 30V MAX VRM 20MA	28480	1501-0040
A1C841	1501-0040	DIODE, SWITCHING, 5I, 30V MAX VRM 20MA	28480	1501-0040
A1C842	1501-0040	DIODE, SWITCHING, 5I, 30V MAX VRM 20MA	28480	1501-0040
A1C843	1502-0766	DIODE, VREG, 18.2V VZ, 5W MAX	28480	1502-0766
A1C844	1501-0040	DIODE, SWITCHING, 5I, 30V MAX VRM 20MA	28480	1501-0040
A1C845	1501-0040	DIODE, SWITCHING, 5I, 30V MAX VRM 20MA	28480	1501-0040
A1C841	1501-0040	DIODE, SWITCHING, 5I, 30V MAX VRM 20MA	28480	1501-0040
A1C861	1502-0638	DIODE, ZENER	28480	1502-0638
A1C862	1501-0040	DIODE, SWITCHING, 5I, 30V MAX VRM 20MA	28480	1501-0040
A1C863	1501-0040	DIODE, SWITCHING, 5I, 30V MAX VRM 20MA	28480	1501-0040
A1C881	1501-0586	DIODE, GEN PNP, 5I, 30V MAX VRM 20MA	28480	1501-0586
A1C882	1501-0586	DIODE, GEN PNP, 5I, 30V MAX VRM 20MA	28480	1501-0586
A1C883	1501-0040	DIODE, SWITCHING, 5I, 30V MAX VRM 20MA	28480	1501-0040
A1C884	1501-0026	DIODE, GEN PNP, 5I, 100V MAX VRM 200MA	28480	1501-0026
A1C11	1826-0055	INTEGRATED CIRCUIT, LIN, OP AMPL	27014	LM201AH
A1C21	1826-0059	INTEGRATED CIRCUIT, LIN, OP AMPL	27014	LM201AH
A1C31	1826-0223	INTEGRATED CIRCUIT, LIN, OP AMPL	27014	LM301A
A1C41	1826-0223	INTEGRATED CIRCUIT, LIN, OP AMPL	27014	LM301A
A1C51	1826-0223	INTEGRATED CIRCUIT, LIN, OP AMPL	27014	LM301A
A1C61	1826-0223	INTEGRATED CIRCUIT, LIN, OP AMPL	27014	LM301A
A1C62	1826-0066	INTEGRATED CIRCUIT, LIN, OP AMPL	07263	U587777J12
A1011	1854-0072	TRANSISTOR, 2N2034 NPN 5I	02725	2N2034
A1012	1854-0071	TRANSISTOR, PNP 5I	28480	1854-0071
A1021	1853-0052	TRANSISTOR, 2N3740 PNP 5I	04713	2N3740
A1022	1853-0056	TRANSISTOR, PNP 5I	28480	1853-0056
A1031	1853-0052	TRANSISTOR, 2N3740 PNP 5I	04713	2N3740
A1032	1853-0053	TRANSISTOR, PNP 5I	28480	1853-0053
A1033	1853-0086	TRANSISTOR, PNP 5I	28480	1853-0086
A1041	1854-0072	TRANSISTOR, 2N3054 NPN 5I	02732	2N3054
A1042	1854-0408	TRANSISTOR, NPN 5I	28480	1854-0408
A1043	1854-0071	TRANSISTOR, NPN 5I	28480	1854-0071
A1051	1854-0083	TRANSISTOR, 2N2035 NPN 5I	02731	2N2035
A1052	1854-0408	TRANSISTOR, NPN 5I	28480	1854-0408
A1053	1854-0071	TRANSISTOR, NPN 5I	28480	1854-0071
A1061	1854-0071	TRANSISTOR, NPN 5I	28480	1854-0071
A1062	1854-0071	TRANSISTOR, NPN 5I	28480	1854-0071
A1063	1853-0086	TRANSISTOR, PNP 5I	28480	1853-0086
A1064	1854-0071	TRANSISTOR, NPN 5I	28480	1854-0071
A1065	1854-0071	TRANSISTOR, NPN 5I	28480	1854-0071
A1066	1854-0071	TRANSISTOR, NPN 5I	28480	1854-0071
A1067	1854-0071	TRANSISTOR, NPN 5I	28480	1854-0071
A1068	1854-0071	TRANSISTOR, NPN 5I	28480	1854-0071
A1611	0683-0345	RESISTOR, FAD, 5.9 OHMS, .25W CC	01121	CR3965
A1612	0683-7505	RESISTOR, FAD, 75 OHMS, .25W CC TUBULAR	01121	CR7505
A1613	0698-3157	RESISTOR, FAD, 10K, .125W F TUBULAR	30582	MF4C1/8-T2-1002-B
A1614	0757-0449	RESISTOR, FAD, 20K, .125W F TUBULAR	24546	CA-1/8-T0-2002-F
A1615	0683-2225	RESISTOR, FAD, 2.2K, .25W CC TUBULAR	01121	CR2225
A1616	0757-0439	RESISTOR, FAD, 6.8K, .125W F TUBULAR	24546	CA-1/8-T0-6811-F
A1617	0757-0250	RESISTOR, FAD, 6.19K, .125W F TUBULAR	30983	MF4C1/8-T0-6191-F
A1618	0683-2235	RESISTOR, FAD, 22K, .25W CC TUBULAR	01121	CR2235

See Introduction to this section for ordering information

Table 6-1. Replaceable Parts(Cont'd)

Reference Designation	HP Part Number	Description	Mfr Code	Mfr Part Number
A1R21	0683-0398	RESISTOR, FAD, 5.4 OHMS, 25W CC	01121	CR3908
A1R22	0683-1018	RESISTOR, FAD, 100 OHMS, 25W CC	01121	CR1018
A1R23	0698-4187	RESISTOR, FAC, 10K, 1% 1/2W F TUBULAR	30583	MFAC178-12-1002-B
A1R24	0787-0449	RESISTOR, FAD, 20K, 1% 1/2W F TUBULAR	24542	CA-178-10-1002-F
A1R25	0683-2226	RESISTOR, FAD, 2.2K, 25W CC TUBULAR	01121	CR2226
A1R26	187-0419	RESISTOR, FAC, 8.6K, 1% 1/2W F TUBULAR	24542	CA-178-10-8611-F
A1R27	1137-0290	RESISTOR, FAD, 8.1K, 1% 1/2W F TUBULAR	30583	MFAC178-10-8191-F
A1R28	0683-2230	RESISTOR, FAD, 2.2K, 25W CC TUBULAR	01121	CR2230
A1R31	0727-0446	RESISTOR, FAC, 2 OHMS, 25W CF TUBULAR	24542	0727-CA46
A1R32	0698-4187	RESISTOR, FAC, 10K, 1% 1/2W F TUBULAR	30583	MFAC178-12-1002-B
A1R33	0698-4187	RESISTOR, FAC, 10K, 1% 1/2W F TUBULAR	30583	MFAC178-12-1002-B
A1R34	0698-2202	RESISTOR, FAC, 1.7K, 1% 1/2W F TUBULAR	16294	CA-178-10-1711-F
A1R35	0787-0403	RESISTOR, FAD, 1.1 OHMS, 1/2W F	24542	CA-178-10-1711-F
A1R36	0698-3484	RESISTOR, FAC, 8.6K, 1% 1/2W F TUBULAR	16294	CA-178-10-8611-F
A1R37	0683-4726	RESISTOR, FAC, 4.7K, 25W CC TUBULAR	01121	CR4726
A1R41	0727-0446	RESISTOR, FAD, 2 OHMS, 25W CF TUBULAR	24542	0727-CA46
A1R42	0698-4187	RESISTOR, FAC, 10K, 1% 1/2W F TUBULAR	30583	MFAC178-12-1002-B
A1R43	0698-4187	RESISTOR, FAC, 10K, 1% 1/2W F TUBULAR	30583	MFAC178-12-1002-B
A1R44	0698-4444	RESISTOR, FAD, 4.0K, 1% 1/2W F TUBULAR	16294	CA-178-10-4011-F
A1R45	0787-0403	RESISTOR, FAD, 1.1 OHMS, 1/2W F	24542	CA-178-10-1711-F
A1R46	0698-3484	RESISTOR, FAC, 8.6K, 1% 1/2W F TUBULAR	16294	CA-178-10-8611-F
A1R47	0683-4726	RESISTOR, FAD, 4.7K, 25W CC TUBULAR	01121	CR4726
A1R51	0812-0066	RESISTOR, FAC, 1.2 OHMS, 2W PW TUBULAR	78042	MM2-13/100-J
A1R52	0698-4187	RESISTOR, FAC, 10K, 1% 1/2W F TUBULAR	30583	MFAC178-12-1002-B
A1R53	0683-4726	RESISTOR, FAD, 4.7K, 25W CC TUBULAR	01121	CR4726
A1R54	0787-0446	RESISTOR, FAD, 1.1 OHMS, 1/2W F TUBULAR	24542	CA-178-10-1711-F
A1R55	0698-3279	RESISTOR, FAD, 4.5K, 1% 1/2W F TUBULAR	16294	CA-178-10-4591-F
A1R61	0698-6977	RESISTOR, FAD, 10K, 1% 1/2W F TUBULAR	30583	MFAC178-15-1002-B
A1R62	0698-6977	RESISTOR, FAD, 10K, 1% 1/2W F TUBULAR	30583	MFAC178-15-1002-B
A1R63	0698-6977	RESISTOR, FAD, 10K, 1% 1/2W F TUBULAR	30583	MFAC178-15-1002-B
A1R64	0698-6977	RESISTOR, FAC, 10K, 1% 1/2W F TUBULAR	30583	MFAC178-15-1002-B
A1R65	0787-0317	RESISTOR, FAD, 1.1 OHMS, 1/2W F TUBULAR	24542	CA-178-10-1711-F
A1R66	0698-6420	RESISTIVE NETWORK, 248 OHM	24542	0698-6420
A1R67	2100-3122	RESISTOR, VAR, TRIM, 100 OHM 10% C	30294	3006Y-1-101
A1R68	0811-9999	RESISTOR, FACTORY SELECTED		
A1R69	0698-6420	RESISTIVE NETWORK, 248 OHM	24542	0698-6420
A1R70	0683-1526	RESISTOR, FAD, 1.5K, 25W CC TUBULAR	01121	CR1526
A1R71	0683-1516	RESISTOR, FAD, 150 OHMS, 25W CC	01121	CR1516
A1R81	0683-2246	RESISTOR, FAD, 220, 25W CC TUBULAR	01121	CR2246
A1R82	0683-4726	RESISTOR, FAC, 4.7K, 25W CC TUBULAR	01121	CR4726
A1R83	0683-4726	RESISTOR, FAC, 4.7K, 25W CC TUBULAR	01121	CR4726
A1R84	0683-4726	RESISTOR, FAC, 4.7K, 25W CC TUBULAR	01121	CR4726
A1R85	0683-8226	RESISTOR, FAD, 8.2K, 25W CC TUBULAR	01121	CR8226
A1R86	0683-8226	RESISTOR, FAD, 8.2K, 25W CC TUBULAR	01121	CR8226
A1R87	0683-8226	RESISTOR, FAD, 8.2K, 25W CC TUBULAR	01121	CR8226
A1R88	0683-8226	RESISTOR, FAD, 8.2K, 25W CC TUBULAR	01121	CR8226
A1R89	0683-2226	RESISTOR, FAD, 2.2K, 25W CC TUBULAR	01121	CR2226
A1R90	0683-8226	RESISTOR, FAD, 8.2K, 25W CC TUBULAR	01121	CR8226
A1R91	0683-1026	RESISTOR, FAD, 10K, 25W CC TUBULAR	01121	CR1026
A1R92	0683-2236	RESISTOR, FAD, 2.2K, 25W CC TUBULAR	01121	CR2236
A1R93	0683-1246	RESISTOR, FAC, 120K, 25W CC TUBULAR	01121	CR1246
A1R94	0683-3936	RESISTOR, FAC, 39K, 25W CC TUBULAR	01121	CR3936
A1R95	0683-1036	RESISTOR, FAD, 10K, 25W CC TUBULAR	01121	CR1036
A1R96	0683-1246	RESISTOR, FAD, 120K, 25W CC TUBULAR	01121	CR1246
A1R97	0683-1036	RESISTOR, FAC, 10K, 25W CC TUBULAR	01121	CR1036
A1R98	0683-3936	RESISTOR, FAD, 39K, 25W CC TUBULAR	01121	CR3936
A1R99	0683-4726	RESISTOR, FAC, 4.7K, 25W CC TUBULAR	01121	CR4726
A1R100	0683-4726	RESISTOR, FAC, 4.7K, 25W CC TUBULAR	01121	CR4726
A1R101	0683-1246	RESISTOR, FAC, 120K, 25W CC TUBULAR	01121	CR1246
A1R102	0683-4726	RESISTOR, FAC, 4.7K, 25W CC TUBULAR	01121	CR4726
A1R103	0683-8226	RESISTOR, FAC, 8.2K, 25W CC TUBULAR	01121	CR8226
A1NPI	1205-0011	HEAT-DISSIPATOR, SGL, TC-3 PKG	2848C	1205-0011
A1MP2	1205-0065	HEAT-DISSIPATOR, SGL, TC-45 PKG	2848C	1205-0065
A1MP3	1205-0209	DISSIPATOR ACCESS CLAMP FLR 1205-0211	2848C	1205-0209
A1MP4	1205-0210	HEAT-DISSIPATOR, SGL, TC-3 PKG	2848C	1205-0210
A1MP5	1205-0259	HEAT-DISSIPATOR, SGL, TC-3 PKG	13103	0104C-1CP
A1MP6	4040-0748	EXTRACTOR/PC BOARD, BLACK	2848D	4040-0748
A1MP7	4040-0749	EXTRACTOR/PC BOARD, BROWN	2848D	4040-0749
A2	03480-66523	CLCK & D/A LOGIC ASSY	2848D	03480-66523
A2C1	0140-0157	CAPACITOR, FAC, 180PF+-5% 300VDC	72126	0M18F181J0300VDCR

See Introduction to this section for ordering information

Table 6-1. Replaceable Parts(Cont'd)

Reference Designation	HP Part Number	Description	Mfr Code	Mfr Part Number
A2CP	0140-0232	CAPACITOR, PAC, 400PF+-10 300WVDC	72132	0M12441F0100WVDC
A2CS	0140-0232	CAPACITOR, PAC, 400PF+-10 300WVDC	72132	0M12441F0200WVDC
A2CA1				
A2CA3	1901-0040	DIODE, SWITCHING, 51, 30V MAX VFM BOMA	28440	1901-0040
A2CL	1820-0596	INTEGRATED CIRCUIT, CGTL, TTL LP DUAL D	27014	0M12744
A2C2	1820-0076	INTEGRATED CIRCUIT, CGTL, TTL DUAL J-7	01296	0M12738
A2C3	1820-0098	INTEGRATED CIRCUIT, CGTL, TTL LP DUAL	27014	0M12738
A2C4	1820-0087	INTEGRATED CIRCUIT, CGTL, TTL 1-5 FLIP	04713	MEM50P
A2C5	1820-0511	INTEGRATED CIRCUIT, CGTL, TTL QUAD 2	01296	0M12708
A2C6	1820-0054	INTEGRATED CIRCUIT, CGTL, TTL QUAD 2	01296	0M12708
A2C7	1820-0096	INTEGRATED CIRCUIT, CGTL, TTL LP DUAL D	27014	0M12744
A2C8	1820-0096	INTEGRATED CIRCUIT, CGTL, TTL LP DUAL D	27014	0M12744
A2C9	1820-0088	INTEGRATED CIRCUIT, CGTL, TTL HEX	01296	0M12708
A2C10	1820-0511	INTEGRATED CIRCUIT, CGTL, TTL QUAD 2	01296	0M12708
A2C11	1820-0054	INTEGRATED CIRCUIT, CGTL, TTL QUAD 2	01296	0M12708
A2C12	1820-0054	INTEGRATED CIRCUIT, CGTL, TTL LP DUAL D	27014	0M12744
A2C13	1820-0054	INTEGRATED CIRCUIT, CGTL, TTL LP DUAL D	27014	0M12744
A2C14	1820-0088	INTEGRATED CIRCUIT, CGTL, TTL HEX	01296	0M12708
A2C15	1820-0511	INTEGRATED CIRCUIT, CGTL, TTL QUAD 2	01296	0M12708
A2C16	1820-0054	INTEGRATED CIRCUIT, CGTL, TTL QUAD 2	01296	0M12708
A2C17	1820-0054	INTEGRATED CIRCUIT, CGTL, TTL LP DUAL D	27014	0M12744
A2C18	1820-0054	INTEGRATED CIRCUIT, CGTL, TTL LP DUAL D	27014	0M12744
A2C19	1820-0511	INTEGRATED CIRCUIT, CGTL, TTL QUAD 2	01296	0M12708
A2C20	1820-0054	INTEGRATED CIRCUIT, CGTL, TTL QUAD 2	01296	0M12708
A2C21	1820-0054	INTEGRATED CIRCUIT, CGTL, TTL LP DUAL D	27014	0M12744
A2C22	1820-0096	INTEGRATED CIRCUIT, CGTL, TTL LP DUAL D	27014	0M12744
A2C23	1820-0088	INTEGRATED CIRCUIT, CGTL, TTL HEX	01296	0M12708
A2C24	1820-0088	INTEGRATED CIRCUIT, CGTL, TTL HEX	01296	0M12708
A201	1854-0010	TRANSISTOR, NPN 51	28440	1854-0010
A202	1854-0071	TRANSISTOR, NPN 51	28440	1854-0071
A203	1854-0071	TRANSISTOR, NPN 51	28440	1854-0071
A204	1854-0071	TRANSISTOR, NPN 51	28440	1854-0071
A205	1854-0071	TRANSISTOR, NPN 51	28440	1854-0071
A206	1854-0071	TRANSISTOR, NPN 51	28440	1854-0071
A207	1854-0071	TRANSISTOR, NPN 51	28440	1854-0071
A208	1854-0071	TRANSISTOR, NPN 51	28440	1854-0071
A209	1854-0071	TRANSISTOR, NPN 51	28440	1854-0071
A210	1854-0071	TRANSISTOR, NPN 51	28440	1854-0071
A211	1854-0071	TRANSISTOR, NPN 51	28440	1854-0071
ALF1	0683-2026	RESISTOR, FAD, 20K 1/2W CC TUBULAR	01121	CR2026
A2R2	0683-1835	RESISTOR, FAD, 18K5 1/2W CC TUBULAR	01121	CR1835
A2R3	0683-1846	RESISTOR, FAD, 18K5 1/2W CC TUBULAR	01121	CR1846
A2R4	0683-4725	RESISTOR, FAD, 4.7K5 1/2W CC TUBULAR	01121	CR4725
A2R5	0683-4725	RESISTOR, FAD, 4.7K5 1/2W CC TUBULAR	01121	CR4725
A2R6	0757-0468	RESISTOR, FAD, 100K 1/2W F TUBULAR	26546	CA-178-TC-1303-F
A2R7	0757-0468	RESISTOR, FAD, 100K 1/2W F TUBULAR	26546	CA-178-TC-1322-F
A2R8	0683-2026	RESISTOR, FAD, 20K 1/2W CC TUBULAR	01121	CR2026
A2R9	1810-0016	KINETICHA 10 RES	18285	20CC-1356-CAP
A2R10	1810-0016	KINETICHA 10 RES	18285	20CC-1376-CAP
A2R11	0683-4725	RESISTOR, FAD, 4.7K5 1/2W CC TUBULAR	01121	CR4725
A2R12	0683-4725	RESISTOR, FAD, 4.7K5 1/2W CC TUBULAR	01121	CR4725
A2R13	0683-4725	RESISTOR, FAD, 4.7K5 1/2W CC TUBULAR	01121	CR4725
A2R14	0683-4725	RESISTOR, FAD, 4.7K5 1/2W CC TUBULAR	01121	CR4725
A2R15	0683-3335	RESISTOR, FAD, 3.3K5 1/2W CC TUBULAR	01121	CR3335
A2R16	0683-3335	RESISTOR, FAD, 3.3K5 1/2W CC TUBULAR	01121	CR3335
A2R17	0683-2026	RESISTOR, FAD, 20K 1/2W CC TUBULAR	01121	CR2026
A2R18	0683-2026	RESISTOR, FAD, 20K 1/2W CC TUBULAR	01121	CR2026
A2R19	0683-2026	RESISTOR, FAD, 20K 1/2W CC TUBULAR	01121	CR2026
A2R20	0683-2026	RESISTOR, FAD, 20K 1/2W CC TUBULAR	01121	CR2026
A2R21	0683-2026	RESISTOR, FAD, 20K 1/2W CC TUBULAR	01121	CR2026
A2R22	0683-2026	RESISTOR, FAD, 20K 1/2W CC TUBULAR	01121	CR2026
A2R23	0683-2026	RESISTOR, FAD, 20K 1/2W CC TUBULAR	01121	CR2026
A2R24	0683-2026	RESISTOR, FAD, 20K 1/2W CC TUBULAR	01121	CR2026
A2R25	0683-3335	RESISTOR, FAD, 3.3K5 1/2W CC TUBULAR	01121	CR3335
A2R26	0683-2026	RESISTOR, FAD, 20K 1/2W CC TUBULAR	01121	CR2026
A2R27	0683-2026	RESISTOR, FAD, 20K 1/2W CC TUBULAR	01121	CR2026
A2R28	0683-2026	RESISTOR, FAD, 20K 1/2W CC TUBULAR	01121	CR2026
A2R29	0683-2026	RESISTOR, FAD, 20K 1/2W CC TUBULAR	01121	CR2026
A2R30	0683-2026	RESISTOR, FAD, 20K 1/2W CC TUBULAR	01121	CR2026
A2R31	0683-2026	RESISTOR, FAD, 20K 1/2W CC TUBULAR	01121	CR2026
A2R32	0683-2026	RESISTOR, FAD, 20K 1/2W CC TUBULAR	01121	CR2026
A2R33	0683-2026	RESISTOR, FAD, 20K 1/2W CC TUBULAR	01121	CR2026
A2H34	0683-1529	RESISTOR, FAD, 1.5K5 1/2W CC TUBULAR	01121	CR1525
J2MP1	1200-0474	SOCKET, ELEC, IC 16-CLMT DIP SLOK TERM	06774	ICN-163-53
A2MP2	4040-0746	EXTRACTOR/PC BOARD, BLACK	28480	4040-0746
A2MP3	4040-0749	EXTRACTOR/PC BOARD, BROWN	28480	4040-0749

See Introduction to this section for ordering information

Table 6-1. Replaceable Parts(Cont'd)

Reference Designation	HP Part Number	Description	Mfr Code	Mfr Part Number
AAK78	2100-0206	RIFAX WM 50 INH 10R LIN 1W	2A481	2100-0216
AAK79	1610-0023	RIFAX WM 10 RES. 1011 REGUHM 01240K INH	06289	200C 1317
AAK80	1100-0034	RIFAX WM 10 RES.	06289	200C-1319-CBA
AAK81	0698-3166	RIFAX NET FLX 14.7K INH 1R 1/2W	2A480	0698-3161
AAK82	0698-4486	RIFAX NET FLX 24.9K INH 1R 1/2W	2A480	0698-4481
AAK83	2100-0434	RIFAX WM 20K INH LIN 20R 1/2W	2A480	2100-0431
AAK84	0811-2764	RIFAX WM 49.4K INH 0.05R 1/2W	2A480	0811-2761
AAK85	0757-0457	RIFAX NET FLX 27.4K INH 1R 1/2W	2A480	0757-0452
AAK86	0698-3220	RIFAX NET FLX 49.4K INH 1R 1/2W	2A480	0698-3221
AAK87	2100-0391	RIFAX WM 1000 INH 20R LIN 1.25W	2A480	2100-0391
AAK88	0811-2764	RIFAX WM 49.4K INH 0.1R 1/2W	2A480	0811-2761
AAK89	0757-0454	RIFAX NET FLX 33.7K INH 1R 1/2W	2A480	0757-0451
AAK90	0757-0460	RIFAX NET FLX 41.9K INH 1R 1/2W	2A480	0757-0452
AAK91	2100-0391	RIFAX WM 1000 INH 20R LIN 1.25W	2A480	2100-0391
AAK92	0811-2764	RIFAX WM 49.4K INH 0.1R 1/2W	2A480	0811-2761
AAK93	0757-0454	RIFAX NET FLX 33.7K INH 1R 1/2W	2A480	0757-0451
AAK94	0698-3220	RIFAX NET FLX 49.4K INH 1R 1/2W	2A480	0698-3221
AAK95	2100-0391	RIFAX WM 10K INH LIN 20R 1W	2A480	2100-0391
AAK96	0698-7371	RIFAX FLX 24.9K INH 1.0R 1/2W	2A480	0698-7371
AAK97	0698-4523	RIFAX FLX 24.9K INH 1R 1/2W	2A480	0698-4521
AAK98	2100-0391	RIFAX WM 10K INH LIN 20R 1W	2A480	2100-0391
AAK99	0757-0472	RIFAX NET FLX 200K INH 1R 1/2W	2A480	0757-0471
AAK100	1410-0030	RIFAX WM 10 RES.	06289	200C-1400-CBA
AAK101	0698-7366	RIFAX FLX 50K INH 0.1R 1/2W	2A480	0698-7361
AAK102	0698-7361	RIFAX FLX 41.9K INH 0.1R 1/2W	2A480	0698-7361
AAK103	0698-7361	RIFAX FLX 41.9K INH 0.1R 1/2W	2A480	0698-7361
AAK104	0698-7360	RIFAX FLX 398.5K INH 0.1R 1/2W	2A480	0698-7360
AAK105	0698-7357	RIFAX FLX 522K INH 0.25R 1/2W	2A480	0698-7357
AAK106	0698-7357	RIFAX FLX 522K INH 0.25R 1/2W	2A480	0698-7357
AAK107	0698-7358	RIFAX FLX 107.5K INH 0.25R 1/2W	2A480	0698-7358
AAK108	0698-7355	RIFAX FLX 444K INH 0.5R 1/2W	2A480	0698-7355
AAK109	0698-7355	RIFAX FLX 444K INH 0.5R 1/2W	2A480	0698-7355
AAK110	0698-7359	RIFAX FLX 83K INH 0.5R 1/2W	2A480	0698-7359
AAK111	1610-0023	RIFAX WM 10 RES.	06289	200C-1600-CBA
AAK112	0757-0481	RIFAX NET FLX 475K INH 11 1/2W	2A480	0757-0481
AAK113	0757-0481	RIFAX NET FLX 475K INH 1R 1/2W	2A480	0757-0481
AAK114	0698-4486	RIFAX NET FLX 24.9K INH 1R 1/2W	2A480	0698-4486
AAK115	0757-0481	RIFAX NET FLX 475K INH 1R 1/2W	2A480	0757-0481
AAK116	0757-0481	RIFAX NET FLX 475K INH 1R 1/2W	2A480	0757-0481
AAK117	0698-3167	RIFAX NET FLX 14.0K INH 1R 1/2W	2A480	0698-3167
AAK118	0757-0481	RIFAX NET FLX 475K INH 1R 1/2W	2A480	0757-0481
AAK119	0757-0481	RIFAX NET FLX 475K INH 1R 1/2W	2A480	0757-0481
AAK120	0698-4020	RIFAX V.53K INH 1R 1/2W	2A480	0698-4020
AAK121	0698-1055	RIFAX COMP 1 REGUHM 5R 1/2W	01121	CA 1055
AAK122	0698-1055	RIFAX COMP 1 REGUHM 5R 1/2W	01121	CA 1055
AAK123	0698-1055	RIFAX COMP 1 REGUHM 5R 1/2W	01121	CA 1055
AAK124	0698-1055	RIFAX COMP 1 REGUHM 5R 1/2W	01121	CA 1055
AAK125	0698-1055	RIFAX COMP 1 REGUHM 5R 1/2W	01121	CA 1055
AAK126	0698-1055	RIFAX COMP 1 REGUHM 5R 1/2W	01121	CA 1055
AAK127	0757-0442	RIFAX NET FLX 10.0K INH 1R 1/2W	2A480	0757-0442

Table 6-1. Replaceable Parts(Con'd)

Reference Designation	HP Part Number	Description	Mfr Code	Mfr Part Number
AB	03480-26570	MASTER BOARD ASSY-C	28480	03480-26570
AB	03480-26572	MASTER BOARD ASSY-D	28480	03480-26572
	NOTE: AS ASSY IS IDENTIFIED UNDER THIS PART NUMBER			
ACC1	0180-0474	CAPACITOR-FAC, 100UF+75-10R 50VDC AL	28285	100J07000012
ACC2	0180-0476	CAPACITOR-FAC 500 UF .10R	28480	0180-0476
ACC3	0180-0470	CAPACITOR-FAC 500 UF .10R	28480	0180-0476
ACC4	0180-0476	CAPACITOR-FAC 500 UF .10R	28480	0180-0476
ACC5	0180-0476	CAPACITOR-FAC 500 UF .10R	28480	0180-0476
ACC6	0180-0476	CAPACITOR-FAC 500 UF .10R	28480	0180-0476
ACC7	0180-0476	CAPACITOR-FAC 500 UF .10R	28480	0180-0476
ACC8	0180-0408	CAPACITOR-FAC, 500UF+75-10R 50VDC AL	28480	0180-0476
ACC9	0180-0408	CAPACITOR-FAC, 100UF+50R 50VDC TA	28285	100D10700012
ACC10	0180-1840	CAPACITOR-FAC, 200UF+10R 50VDC TA	28285	100D20500012
ACC11	0180-0121	CAPACITOR-FAC, 100UF+10R 50VDC TA	28480	0180-0121
ACC12	0180-1840	CAPACITOR-FAC, 200UF+10R 50VDC TA	28285	100D20500012
ACC13	0180-0110	CAPACITOR-FAC, 500UF+10R 50VDC TA	28285	100D05500012
ACC14	0180-1702	CAPACITOR-FAC, 100UF+20R 50VDC TA-SOLID	28285	100D10700012
ACC15	0180-1830	CAPACITOR-FAC, 500UF+20R 50VDC TA-SOLID	28285	100D05500012
ACC16	1501-0364	DIODE, MULT, FULL WAVE BRIDGE RECTIFIER	28480	1501-0364
ACC17	1501-0364	DIODE, MULT, FULL WAVE BRIDGE RECTIFIER	28480	1501-0364
ACC18	1502-3158	DIODE, VREG, 12.7V VZ, 1AW MAX	28480	1502-3158
ACC19	1502-0202	DIODE, VREG, 16.2V VZ, 1AW MAX	28480	1502-0202
ACC20	1501-1232	DIODE, VREG, 5.6V VZ, 1CW MAX	28480	1501-1232
ACC21	1501-0028	DIODE, PWR RECT, 5I, 500V MAX VFM 780MA	28480	1501-0028
ACC22	1501-0028	DIODE, PWR RECT, 5I, 500V MAX VFM 780MA	28480	1501-0028
ACC23	1501-0028	DIODE, MULT, FULL WAVE BRIDGE RECTIFIER	28480	1501-0028
ACC24	1502-0184	DIODE, VREG, 16.2V VZ, 1AW MAX	28480	1502-0184
ACC25	1501-0364	DIODE, MULT, FULL WAVE BRIDGE RECTIFIER	28480	1501-0364
ADD1	1550-0359	PHOTO-DEVICE, DIP, NUM 2200W PD	28480	1550-0359
ADD2	1550-0330	PHOTO-DEVICE, DIP, NUM 9500W PD	28480	1550-0330
ADD3	1550-0330	PHOTO-DEVICE, DIP, NUM 9500W PD	28480	1550-0330
ADD4	1550-0330	PHOTO-DEVICE, DIP, NUM 9500W PD	28480	1550-0330
ADD5	1550-0330	PHOTO-DEVICE, DIP, NUM 9500W PD	28480	1550-0330
ADD6	1550-0330	PHOTO-DEVICE, DIP, NUM 9500W PD	28480	1550-0330
ADD7	2110-0002	FUSE, 2A 250V	71407	ACC-2
AEJ1	1251-1866	CONNECTOR, PC EDGE, 16-CON, DIP SOLDER	71785	252-15-30-340
AEJ2	1251-1863	CONNECTOR, PC EDGE, 16-CON, DIP SOLDER	71785	252-15-30-310
AEJ3	1251-1866	CONNECTOR, PC EDGE, 16-CON, DIP SOLDER	71785	252-15-30-310
AEJ4	1251-1866	CONNECTOR, PC EDGE, 16-CON, DIP SOLDER	71785	252-15-30-310
AEJ5	1251-1866	CONNECTOR, PC EDGE, 16-CON, DIP SOLDER	71785	252-15-30-310
AEJ6	1251-1866	CONNECTOR, PC EDGE, 16-CON, DIP SOLDER	71785	252-15-30-310
AEJ7	1251-1866	CONNECTOR, PC EDGE, 16-CON, DIP SOLDER	71785	252-15-30-310
AEJ8	1251-1866	CONNECTOR, PC EDGE, 16-CON, DIP SOLDER	71785	252-15-30-310
AEJ9	1251-1866	CONNECTOR, PC EDGE, 16-CON, DIP SOLDER	71785	252-15-30-310
AEJ10	1251-1866	CONNECTOR, PC EDGE, 16-CON, DIP SOLDER	71785	252-15-30-310
AEJ11	1251-1866	CONNECTOR, PC EDGE, 16-CON, DIP SOLDER	71785	252-15-30-310
AEJ12	1251-1866	CONNECTOR, PC EDGE, 16-CON, DIP SOLDER	71785	252-15-30-310
AEK1	0683-2720	RESISTOR, FAD, 2.7K 1/2W CC TUBULAR	01121	0683-2720
AEK2	0683-2720	RESISTOR, FAD, 2.7K 1/2W CC TUBULAR	01121	0683-2720
AEK3	0683-2720	RESISTOR, FAD, 2.7K 1/2W CC TUBULAR	01121	0683-2720
AEK4	0683-2720	RESISTOR, FAD, 2.7K 1/2W CC TUBULAR	01121	0683-2720
AEK5	0683-2720	RESISTOR, FAD, 2.7K 1/2W CC TUBULAR	01121	0683-2720
AEK6	03480-01102	HEAT SINK	28480	03480-01102
AEK7	03480-01103	HEAT SINK-DIODE	28480	03480-01103
AEK8	03480-01104	HEAT SINK-DISPLAY	28480	03480-01104
AEK9	03480-04702	SUPPORT BOARD	28480	03480-04702
AEK10	03480-04703	SUPPORT BOARD	28480	03480-04703
AEK11	03480-04704	SUPPORT BOARD	28480	03480-04704
AEK12	0403-0183	GUIDE, PC BOARD, 1 L, 25 W LEXAN	28480	0403-0183
AEK13	0403-0185	GUIDE, PC BOARD, 1 L, 25 W LEXAN	28480	0403-0185
AEK14	2110-0225	CLIP/FUSE 0.250" DIA	71802	2008-2508
AT	03480-26570	DISPLAY ASSY	28480	03480-26570
ATC1-C15	1000-0445	DIODE LED HIGH REQ'D 2500-0362 (2 EA)	28480	1000-0445

See Introduction to this section for ordering information

Table 6-1. Replaceable Parts(Cont'd)

Reference Designation	HP Part Number	Description	Mfr Code	Mfr Part Number
A13011	1854-0071	1854-0071	28480	1854-0071
A13012	1854-0071	1854-0071	28480	1854-0071
A13013	1854-0071	1854-0071	28480	1854-0071
A13014	1853-0001	1853-0001	28480	1853-0001
A13015	1854-0071	1854-0071	28480	1854-0071
A13016	1853-0004	1853-0004	28480	1853-0004
A13017	1854-0215	1854-0215	28480	1854-0215
A13018	1854-0215	1854-0215	28480	1854-0215
A13019	0698-7479	0698-7479	28480	0698-7479
A1302	2100-2670	2100-2670	28480	2100-2670
A1303	0684-3331	0684-3331	01121	CR 3331
A1304	0684-3031	0684-3031	01121	CR 3031
A1305	0684-3331	0684-3331	01121	CR 3331
A1306	2100-2633	2100-2633	28480	2100-2633
A1307	0757-0442	0757-0442	28480	0757-0442
A1308	0757-0442	0757-0442	28480	0757-0442
A1309	0757-0442	0757-0442	28480	0757-0442
A1310	0757-0446	0757-0446	28480	0757-0446
A1311	0757-0446	0757-0446	28480	0757-0446
A1312	0757-0434	0757-0434	28480	0757-0434
A1313	0684-4711	0684-4711	01121	CR 4711
A1314	0684-1031	0684-1031	01121	CR 1031
A1315	0757-0407	0757-0407	28480	0757-0407
A1316	0684-1031	0684-1031	01121	CR 1031
A1317	0757-0442	0757-0442	28480	0757-0442
A1318	0684-4711	0684-4711	01121	CR 4711
A1319	0684-1031	0684-1031	01121	CR 1031
A1320	0757-0280	0757-0280	28480	0757-0280
A1321	0684-3331	0684-3331	01121	CR 3331
A1322	0698-4421	0698-4421	28480	0698-4421
A1323	2100-2574	2100-2574	28480	2100-2574
A1324	0698-3493	0698-3493	28480	0698-3493
A1325	0757-0465	0757-0465	28480	0757-0465
A1326	0757-0465	0757-0465	28480	0757-0465
A1327	0698-7479	0698-7479	28480	0698-7479
A1328	0684-1021	0684-1021	01121	CR 1021
A1329	0757-0442	0757-0442	28480	0757-0442
A1330	0757-0474	0757-0474	28480	0757-0474
A1331	2100-2514	2100-2514	28480	2100-2514
A1332	0757-0442	0757-0442	28480	0757-0442
A1333	0611-1142	0611-1142	28480	0611-1142
A1334	2100-2583	2100-2583	28480	2100-2583
A1335	0698-4443	0698-4443	28480	0698-4443
A1336	0698-4434	0698-4434	28480	0698-4434
A1337	0698-4121	0698-4121	28480	0698-4121
A1338	2100-2413	2100-2413	28480	2100-2413
A1339	0698-4123	0698-4123	28480	0698-4123
A1340	0698-4534	0698-4534	28480	0698-4534
A1341	0757-0465	0757-0465	28480	0757-0465
A1342	0757-0442	0757-0442	28480	0757-0442
A1343	0684-2231	0684-2231	01121	CR 2231
A1344	0684-4731	0684-4731	01121	CR 4731
A1345	0684-4721	0684-4721	01121	CR 4721
A1346	0684-2231	0684-2231	01121	CR 2231
A1347	0684-1031	0684-1031	01121	CR 1031
A1348	0684-2221	0684-2221	01121	CR 2221
A1349	0684-1031	0684-1031	01121	CR 1031
A1350	0684-1031	0684-1031	01121	CR 1031
A1351	0698-4473	0698-4473	28480	0698-4473
A1352	2100-2413	2100-2413	28480	2100-2413
A1353	0684-1021	0684-1021	01121	CR 1021
A1354	0757-0442	0757-0442	28480	0757-0442
A1355	0757-0442	0757-0442	28480	0757-0442
A1356	0698-4308	0698-4308	28480	0698-4308
A1357	0684-1031	0684-1031	01121	CR 1031
A1358	0684-4721	0684-4721	01121	CR 4721
A1359	0684-2231	0684-2231	01121	CR 2231
A1360	0757-0437	0757-0437	28480	0757-0437
A1361	0684-1031	0684-1031	01121	CR 1031
A1362	0698-3184	0698-3184	28480	0698-3184
A1363	0684-4721	0684-4721	01121	CR 4721
A1364	0698-3242	0698-3242	28480	0698-3242
A1365	0698-3242	0698-3242	28480	0698-3242
A1366	0698-4431	0698-4431	28480	0698-4431
A1367	0698-4431	0698-4431	28480	0698-4431
F13	1381-0016	CONNECTOR: 80-PIN, MATES WITH BCD CONNECTOR J13	07860	87-30680-376
F15	1381-1767	CONNECTOR: 8-PIN, MATES WITH SAMPLE/HOLD CONNECTOR J15	07860	138-370

See Introduction to this section for ordering information

Table 6-1. Replaceable Parts(Cont'd)

Reference Designation	Part Number	Description	Mfr Code	Mfr Part Number
CHASSIS & MISCELLANEOUS PARTS				
C1	0160-0117	CAPACITOR-FXD 01UF 20MVAC	78480	0160-0110
F1	7110-0001	FUSE, 1A 250V	71400	AGC-1
F1	7110-0717	FUSE, 115V OPERATIONAL	71400	AGC 1/2
		FUSE, 5A 250V		
		FUSE, 250V OPERATIONAL		
NP1	03480-04704	SUPPORT BOARD FRONT	78480	03480-04704
NP2	03480-20601	SHIELD SW TCH	78480	03480-20601
NP2A	03480-04707	SUPPORT BOARD, REAR, RIGHT	78480	03480-04707
NP3B	03480-04703	SUPPORT BOARD, REAR, LEFT	78480	03480-04703
NP4	03480-0601	SHIELD REAR	78480	03480-0601
NP5	03480-04107	COVER TOP C	78480	03480-04107
NP6	03480-20604	TRIM TOP C	78480	03480-20604
NP7	03480-04103	COVER SIDE C	78480	03480-04103
NP8	03480-22003	FRAME SIDE C	78480	03480-22003
NP9	4040-0666	WINDOW-C	78480	4040-0666
NP10	03480-22001	FRAME FRONT C	78480	03480-22001
NP11	03480-04101	COVER BOTTOM C	78480	03480-04101
NP12	5060-0726	FOOT ASSY WALL MODUL	78480	5060-0726
NP13	1400-1103	STAND TILT C	78480	1400-1103
NP14	03480-00713	PANEL SUB REAR C	78480	03480-00713
NP16	03480-22002	FRAME REAR C	78480	03480-22002
NP17	03480-00719	PANEL LOWER REAR C	78480	03480-00719
NP18	03480-60313	PANEL ASSY UPPER REAR C	78480	03480-60313
NP19	03480-00616	SHIELD	78480	03480-00616
NP19	03480-04106	COVER TOP D	78480	03480-04106
NP20	03480-20602	TRIM TOP D	78480	03480-20602
NP21	03480-04107	COVER SIDE D	78480	03480-04107
NP22	5060-0060	TRIM SIDES	78480	5060-0060
NP23	03480-22006	SIDE-FRAME RIGHT D	78480	03480-22006
NP24	03480-22004	FRAME FINISHED D	78480	03480-22004
NP25	03480-20603	TRIM BOTTOM D	78480	03480-20603
NP26	4040-0666	WINDOW-D	78480	4040-0666
NP27	03480-04104	COVER BOTTOM D	78480	03480-04104
NP28	1400-0030	STAND TILT D	78480	1400-0030
NP29	5060-0767	FOOT ASSY FM	78480	5060-0767
NP30	03480-22006	SIDE-FRAME LEFT D	78480	03480-22006
NP31	03480-00718	PANEL REAR D	78480	03480-00718
NP32	03480-00214	PANEL SUB REAR D	78480	03480-00214
NP33	03480-00216	OVER PANEL STANDARD D	78480	03480-00216
NP34	03480-00217	OVER PANEL BL'D D	78480	03480-00217
NP35	03480-00216	PANEL DUMMY C	78480	03480-00216
NP36	03480-00601	EXTRUSION WINDOW C	78480	03480-00601
NP37	03480-00604	SHIELD FILT CR	78480	03480-00604
NP41	03480-84401	WHEELS-ORY KIT D	78480	03480-84401
NP42	5060-0033	FOOT ASSY BIT	78480	5060-0033
NP43	1761-1767	CONNECTOR A & P 0 FEMALE #20 CONTACTS	62650	176-220
NP46	7124-2231	PLATE "OPTION 001"	78480	7124-2231
NP49	1400-0783	CLAMP, CABLE, 218 DIA .438 W .718L	05087	CK75A
NP60	03480-20601	FIELD SWITCH	78480	03480-20601
NP61	03480-24701	SPACER CONNECTOR	78480	03480-24701
NP62	11166-04303	FILLER SH PANEL	78480	11166-04303
S1	7101-1268	SWITCH TGL 6PDT 2A/250VAC ON-NONE-ON	03363	7101-1
T1	2500-3472	TRANSFORMER POWER	78480	0100-3472
W1	8170-1348	CABLE, UNSHLD 3-COND 10.4MS	70903	KHS-7041
W2	03480-81601	CABLE LINE POWER	78480	03480-81601
W3	03480-81611	CABLE MAIN	78480	03480-81611
W4	03480-81610	CABLE MAIN, STANDARD	78480	03480-81610
XF1	1400-0360	FUSEHOLDER, EXTR POST, BAY CAP, 15A	76916	347004

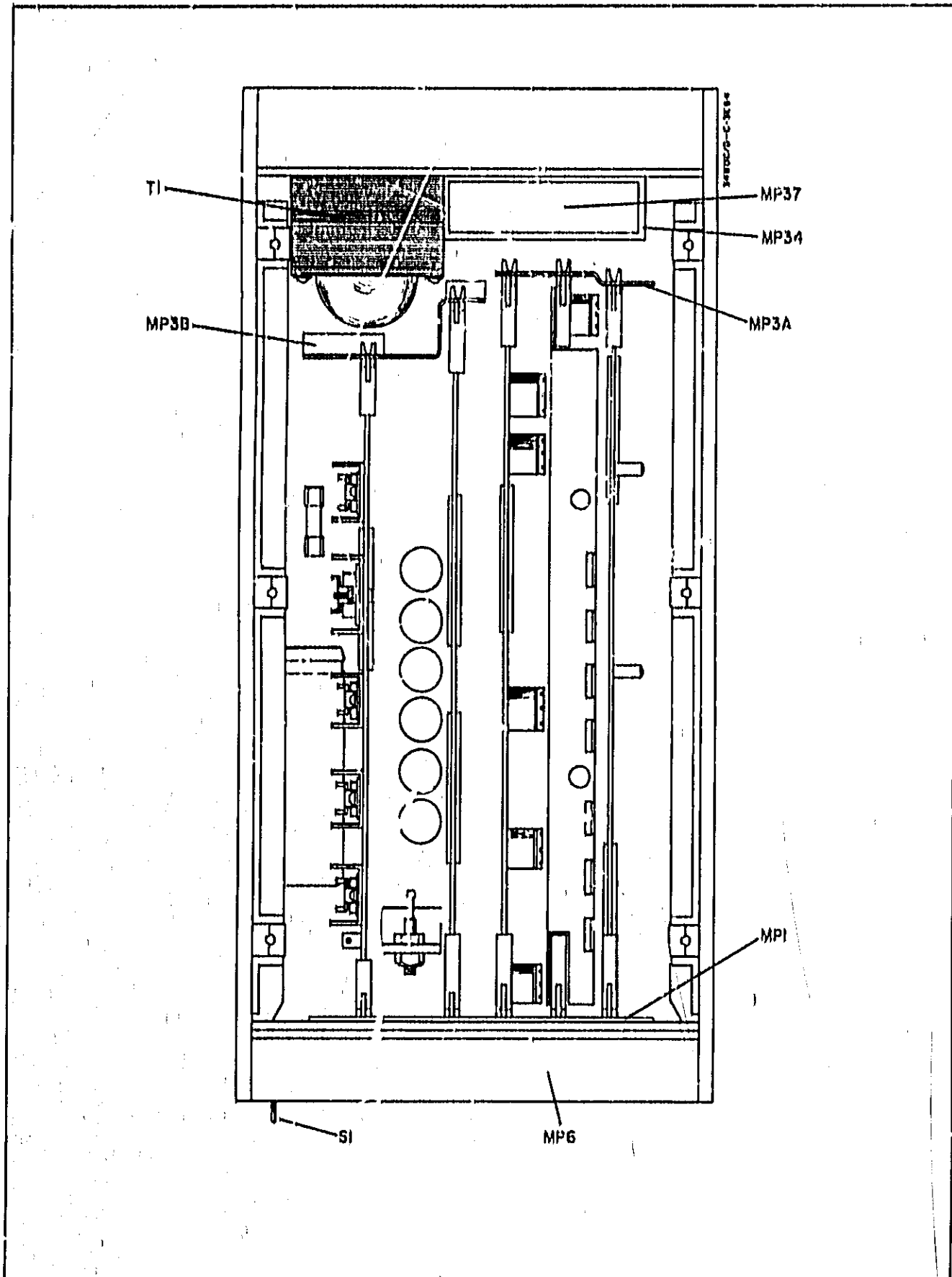

Figure 6-1, Location of Miscellaneous Parts,

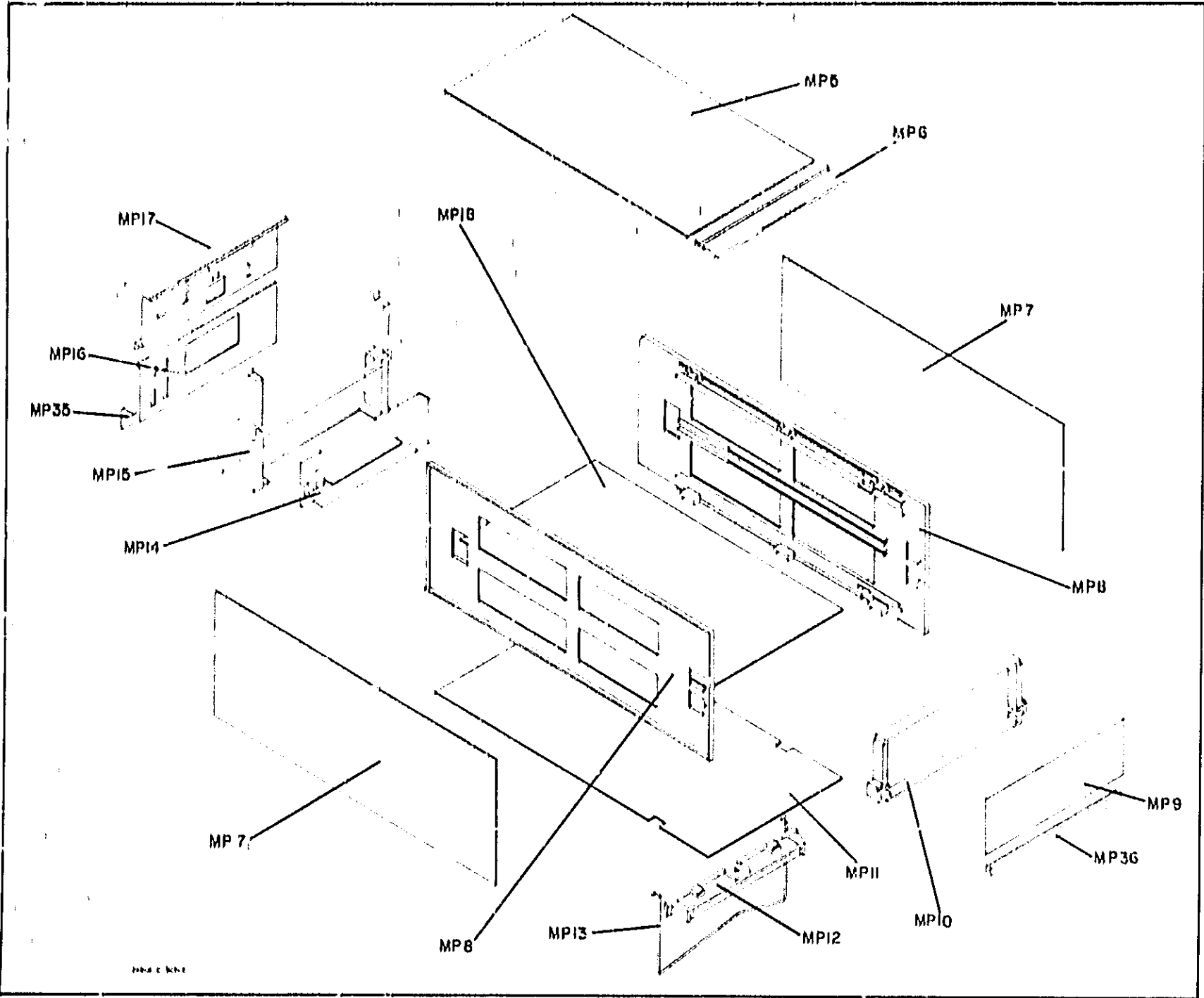

Figure 6-2. Location of Cabinet Parts, 3480C.

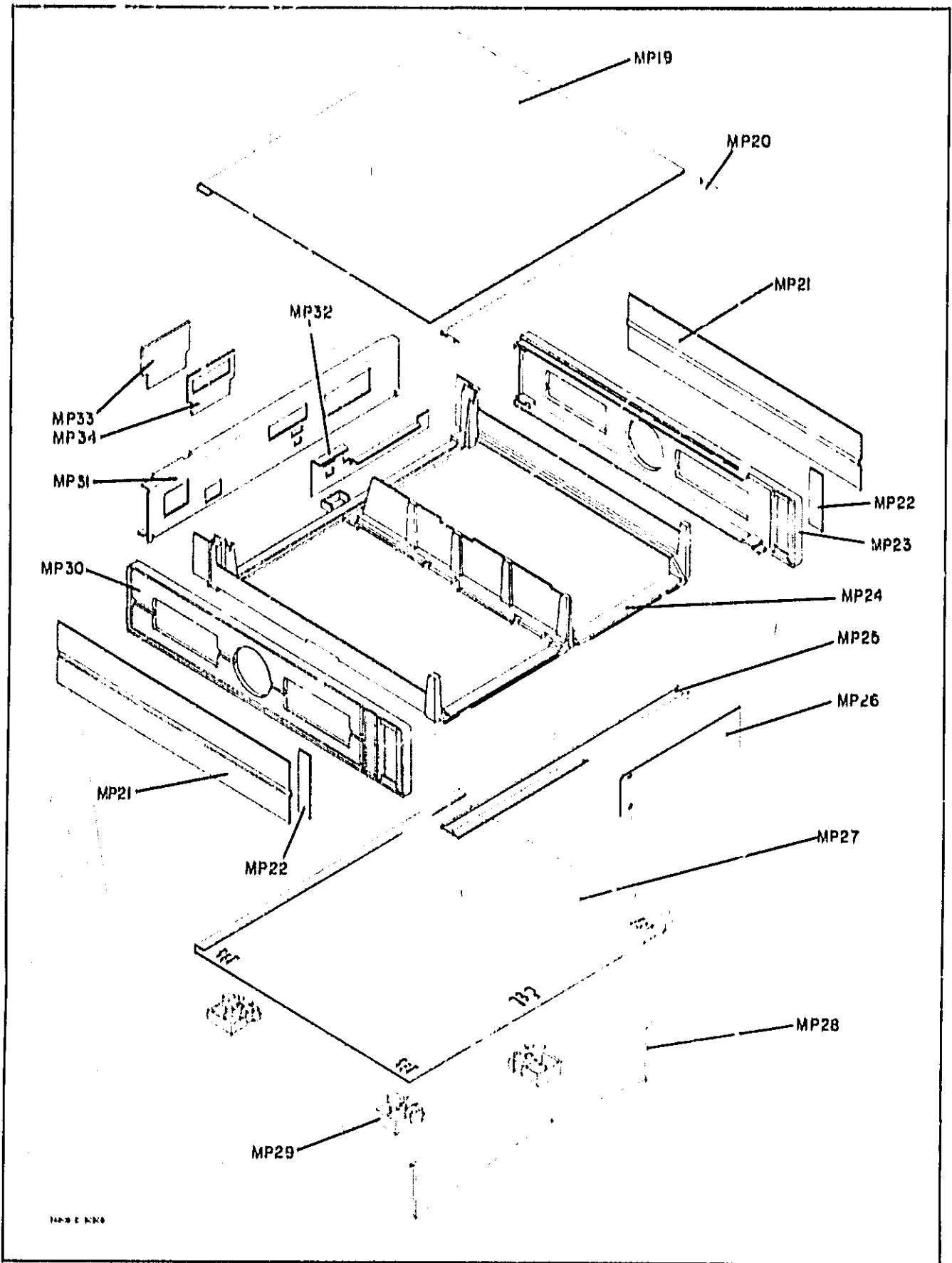

Figure G-3. Location of Cabinet Parts, 3480D.

SCHEMATIC DIAGRAMS

SECTION VII CIRCUIT DIAGRAMS











7-1. INTRODUCTION.

7-2. This section contains the diagrams necessary to maintain the Model 3480C/D. Both schematic diagrams and pictorial views of the circuit boards are included. Figure 7-1 shows the location of the various assemblies, and Figure 7-2 is a functional block diagram. Figure 7-3 shows correct waveforms to be found at various points within the instrument. These waveform location points are noted by number on the schematic diagrams. Figure 7-23 shows the interconnections between printed circuit connectors on the master board assembly A6. This diagram also shows connections to the plug-in connector J12.

7-3. NOTES.

7-4. The following notes apply in general to all schematic diagrams.

1. Partial reference designators are shown within assembly outlines. Prefix with assembly number for complete designator.
2. Component values are shown as follows unless otherwise noted:
 - Capacitance in microfarads
 - Resistance in ohms
3. " Average value shown. Optimum value selected at factory.

4.  Denotes assembly,
5.  Denotes main signal path,
6.  Denotes feedback path,
7.  OR  Denotes screwdriver adjustment,
8.  Denotes front panel marking,
9.  Denotes rear panel marking,
10.  High current ground and  Low current ground are both connected to Input Low terminal,
11.  Denotes chassis ground and outward circuit ground,
12. 924 Denotes wire color. Color code is the same as the resistor color code. First number identifies the base color; second identifies the wider strip; and third number identifies the narrower strip (e.g. 924 = white, red, yellow).

REFERENCE DESIGNATIONS

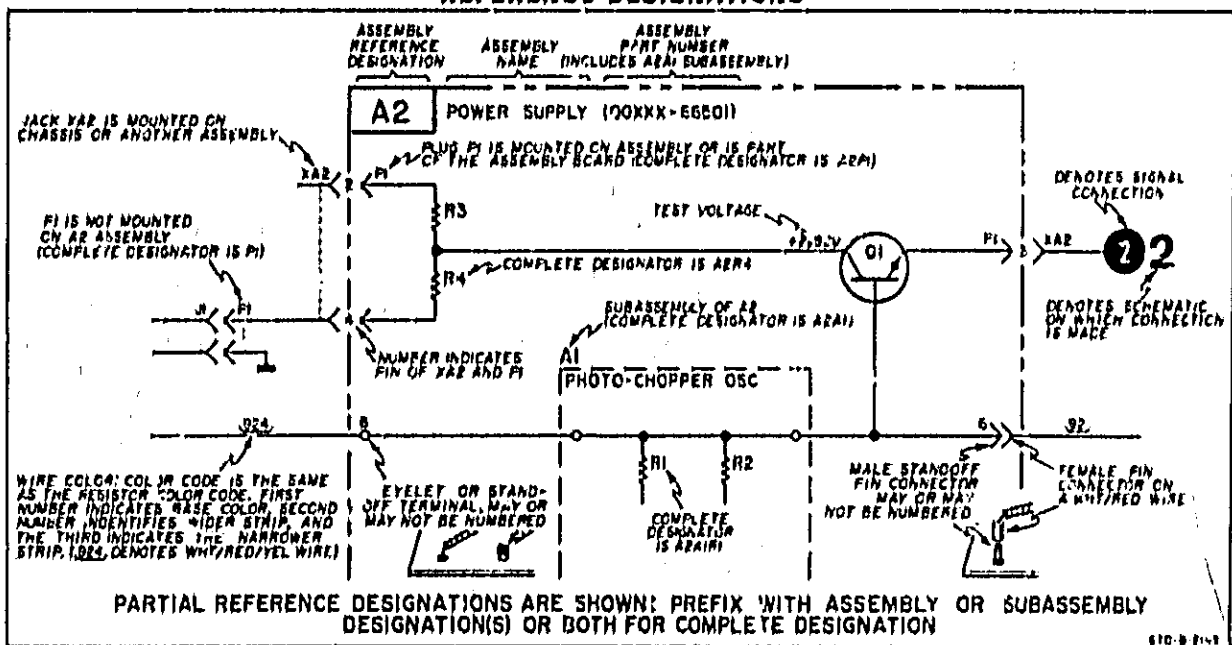

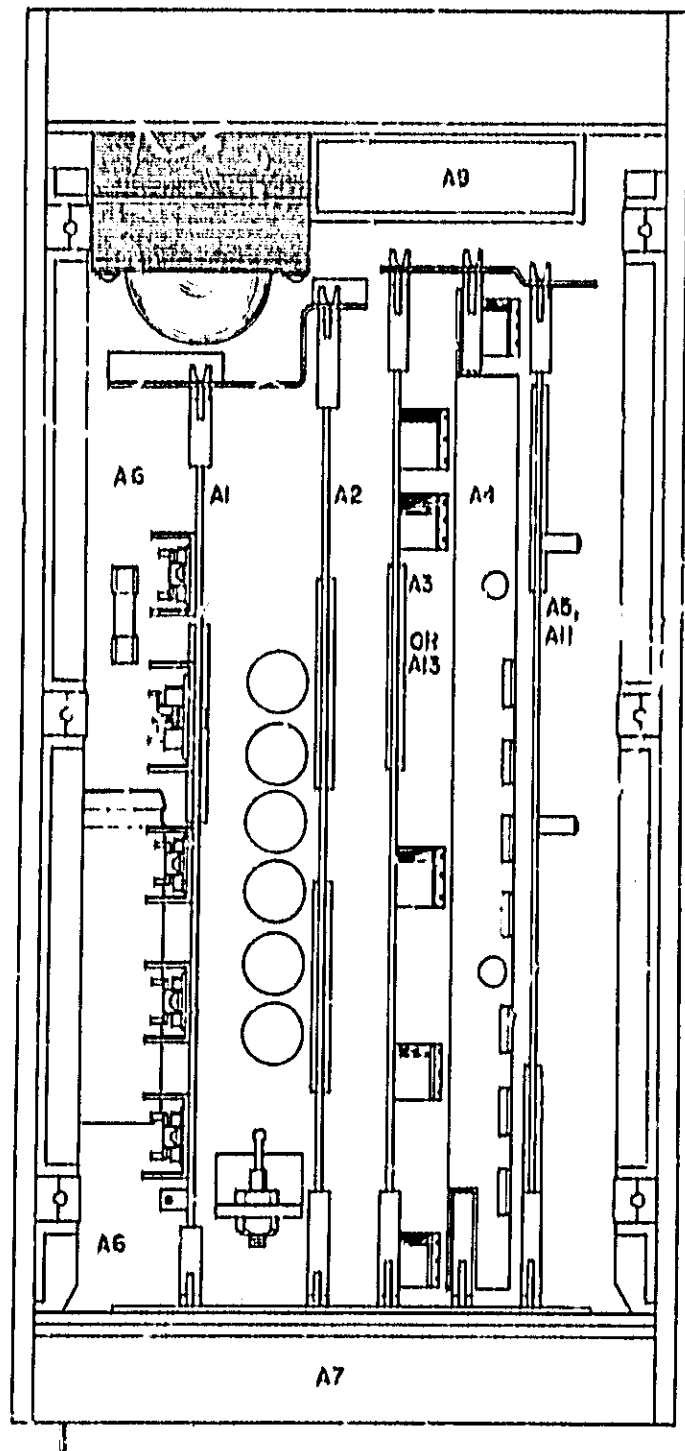
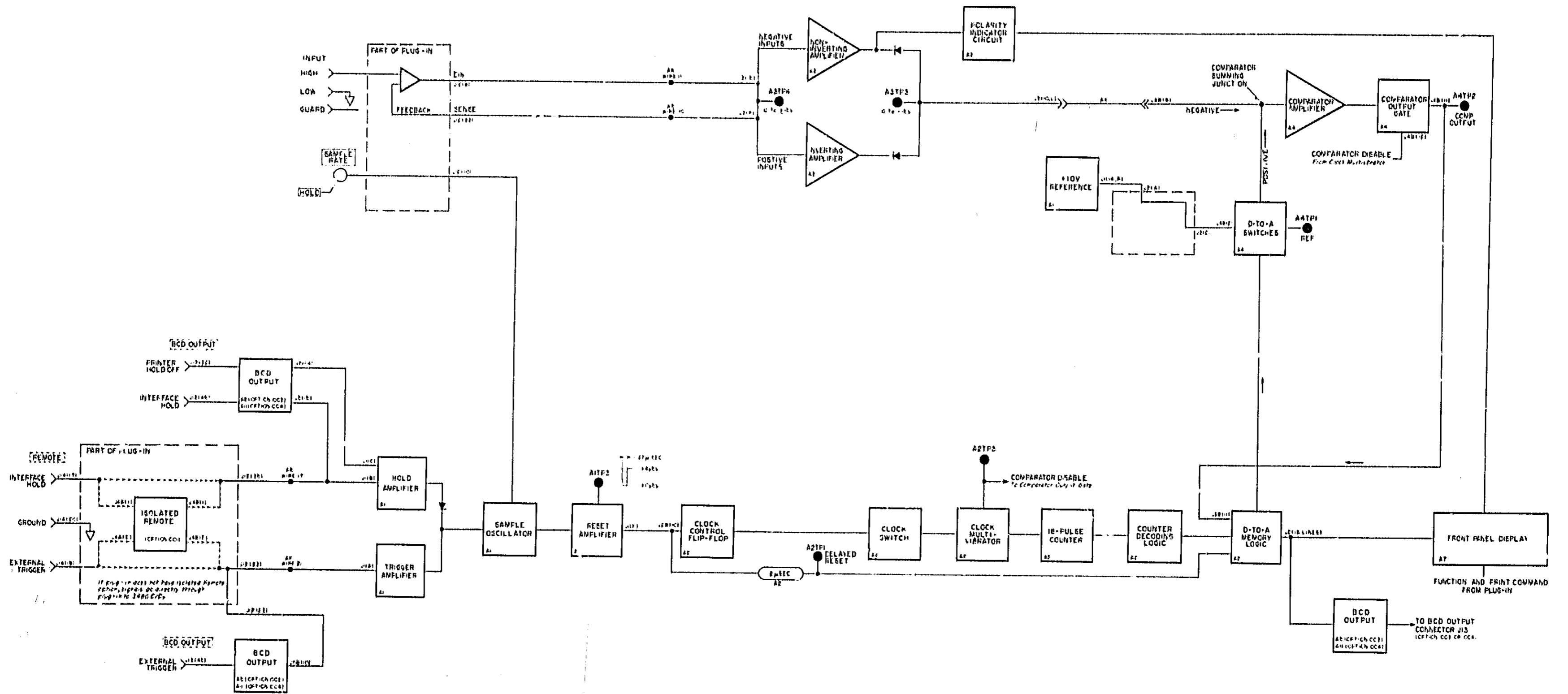
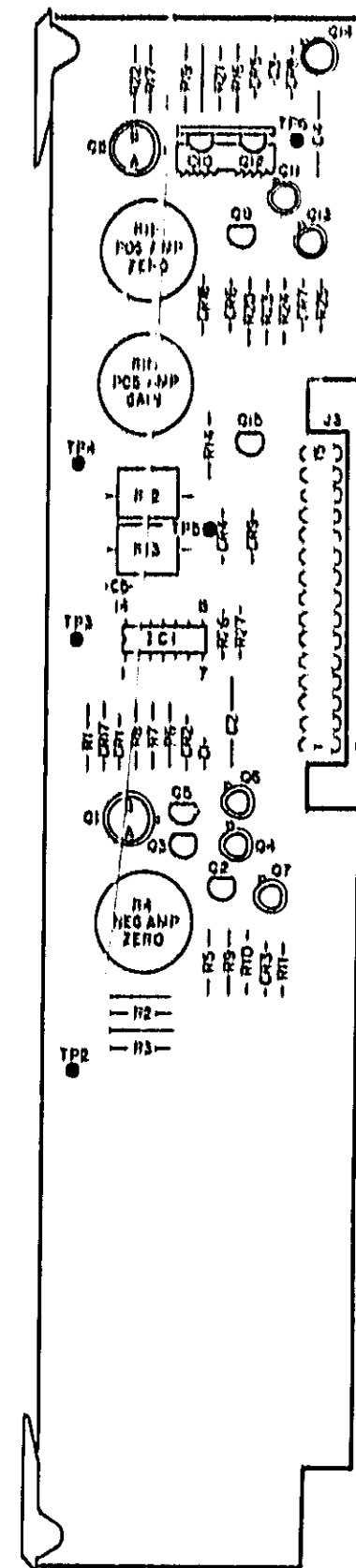

Figure 7-1. Location of Assemblies.



PARCA-1-10000A
 COPYRIGHT 1970 BY HEWLETT-PACKARD COMPANY

Figure 7-2. Block Diagram
 7-3/7



A3
POLARITY AMP
ASSEMBLY

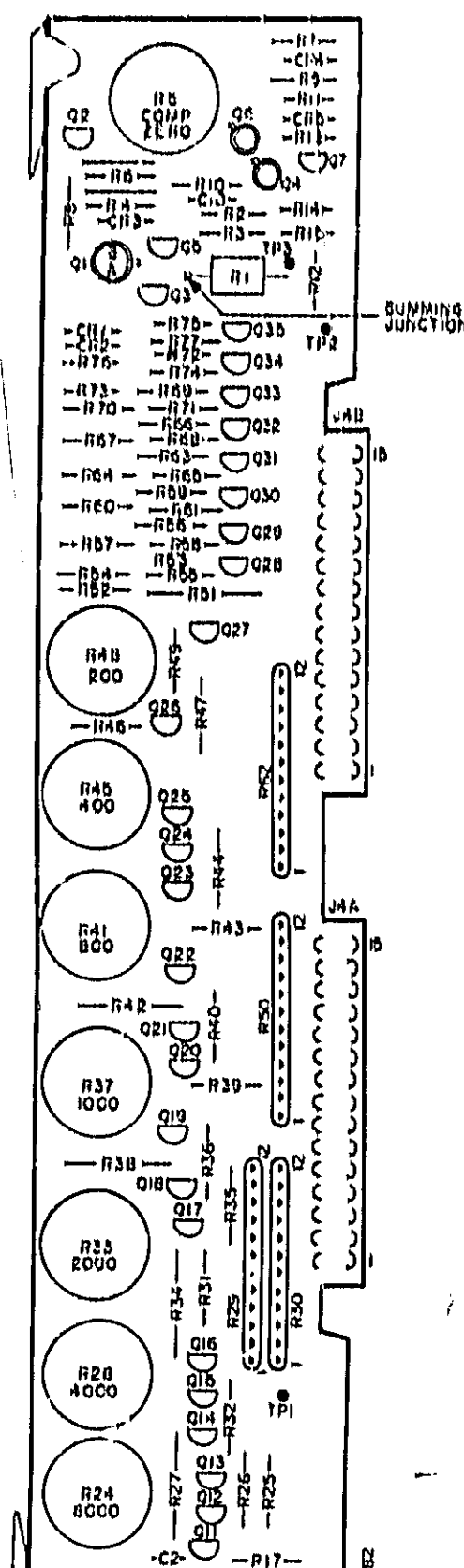

A4
D/A COMP
ASSEMBLY

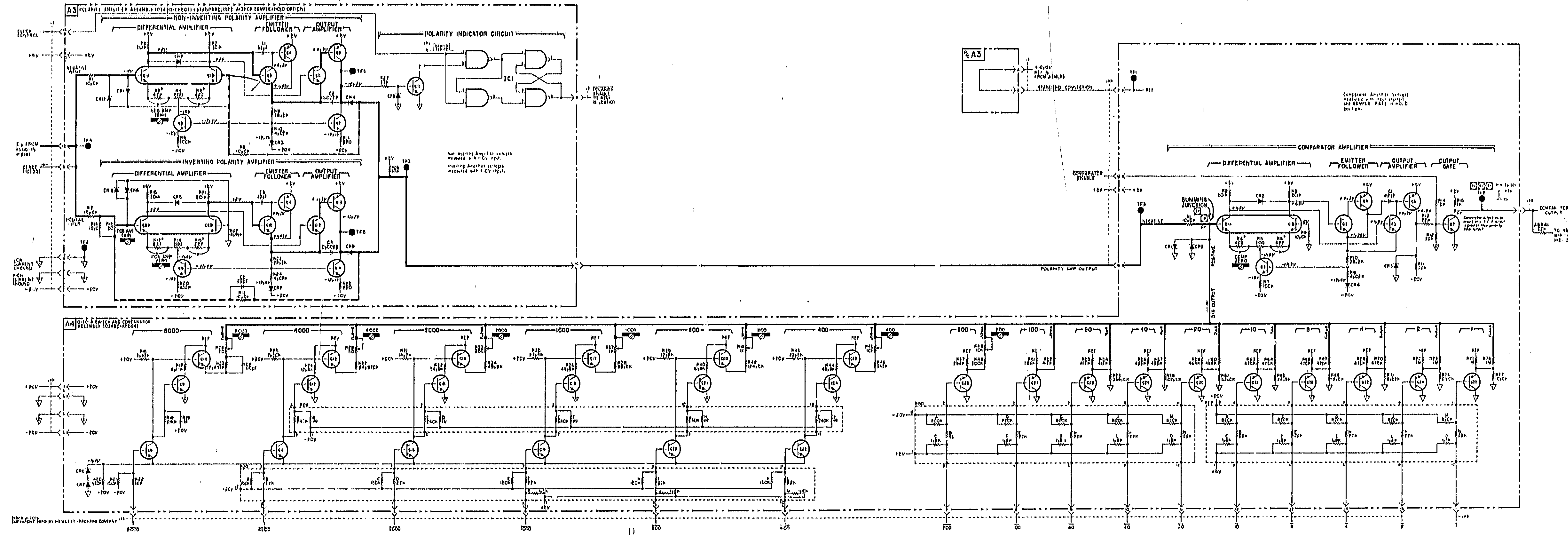

Figure 7-3. Schematic Diagram, Polarity Amplifier Assembly A3; D/A and Comparator Assembly A4.

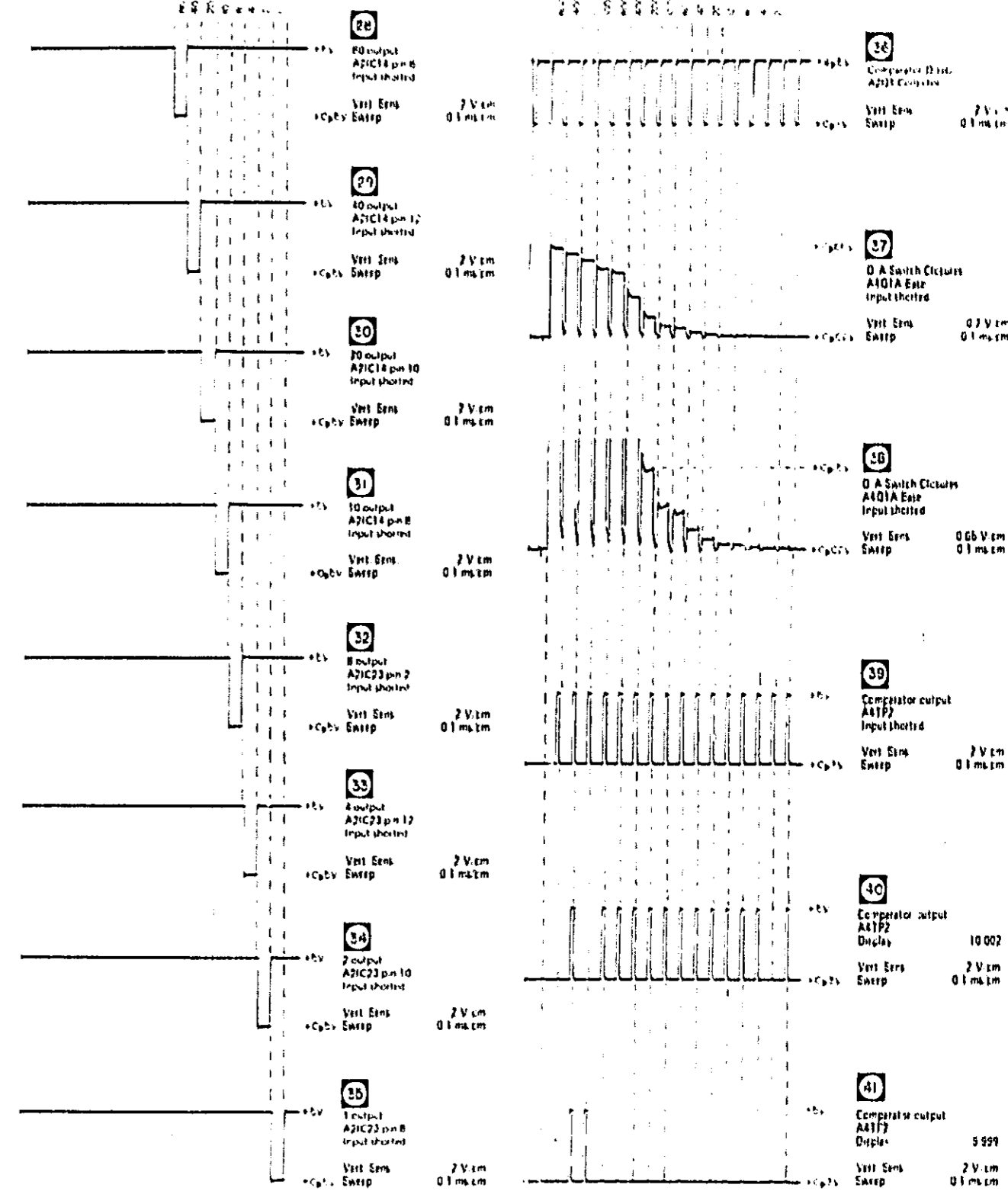
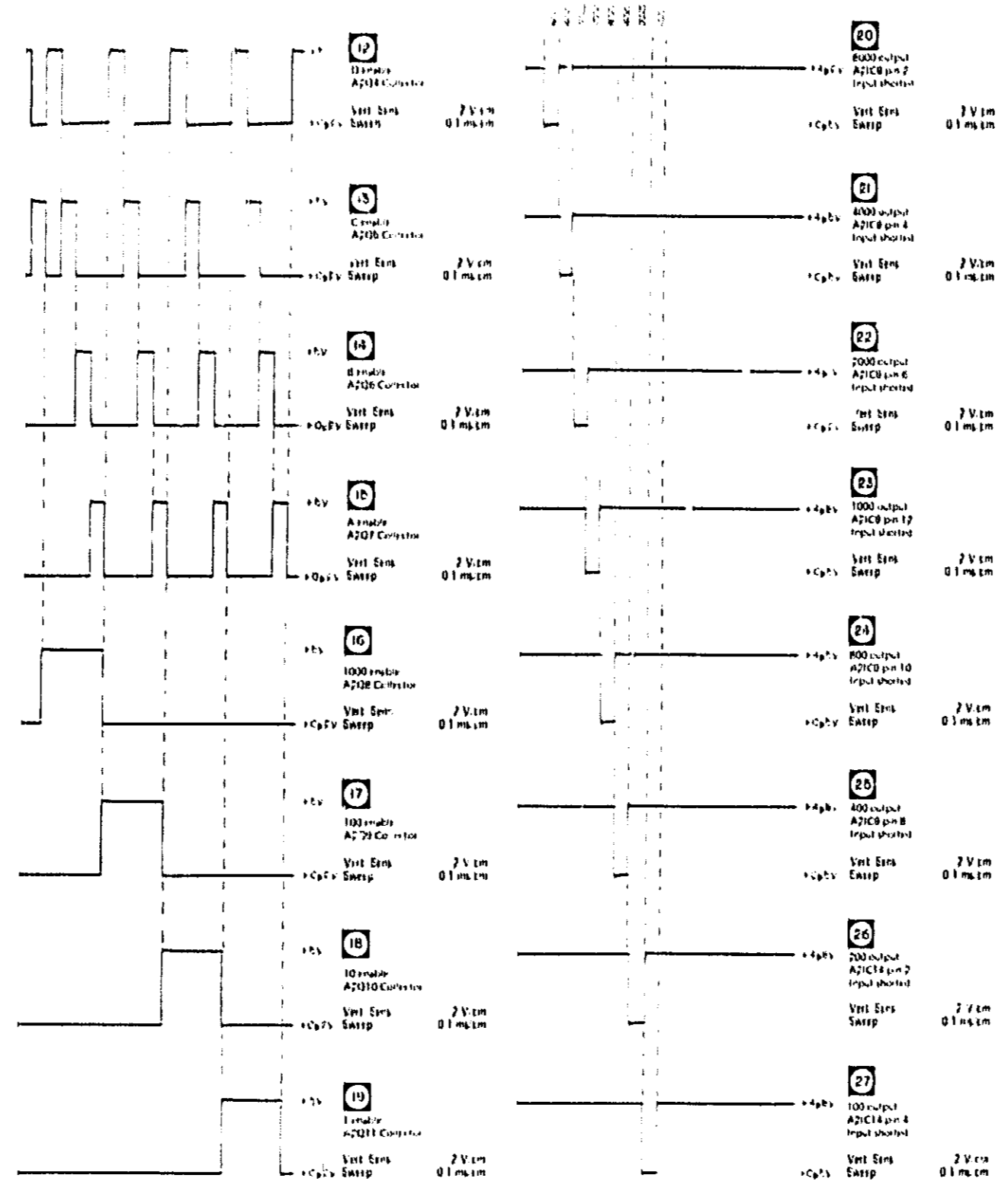
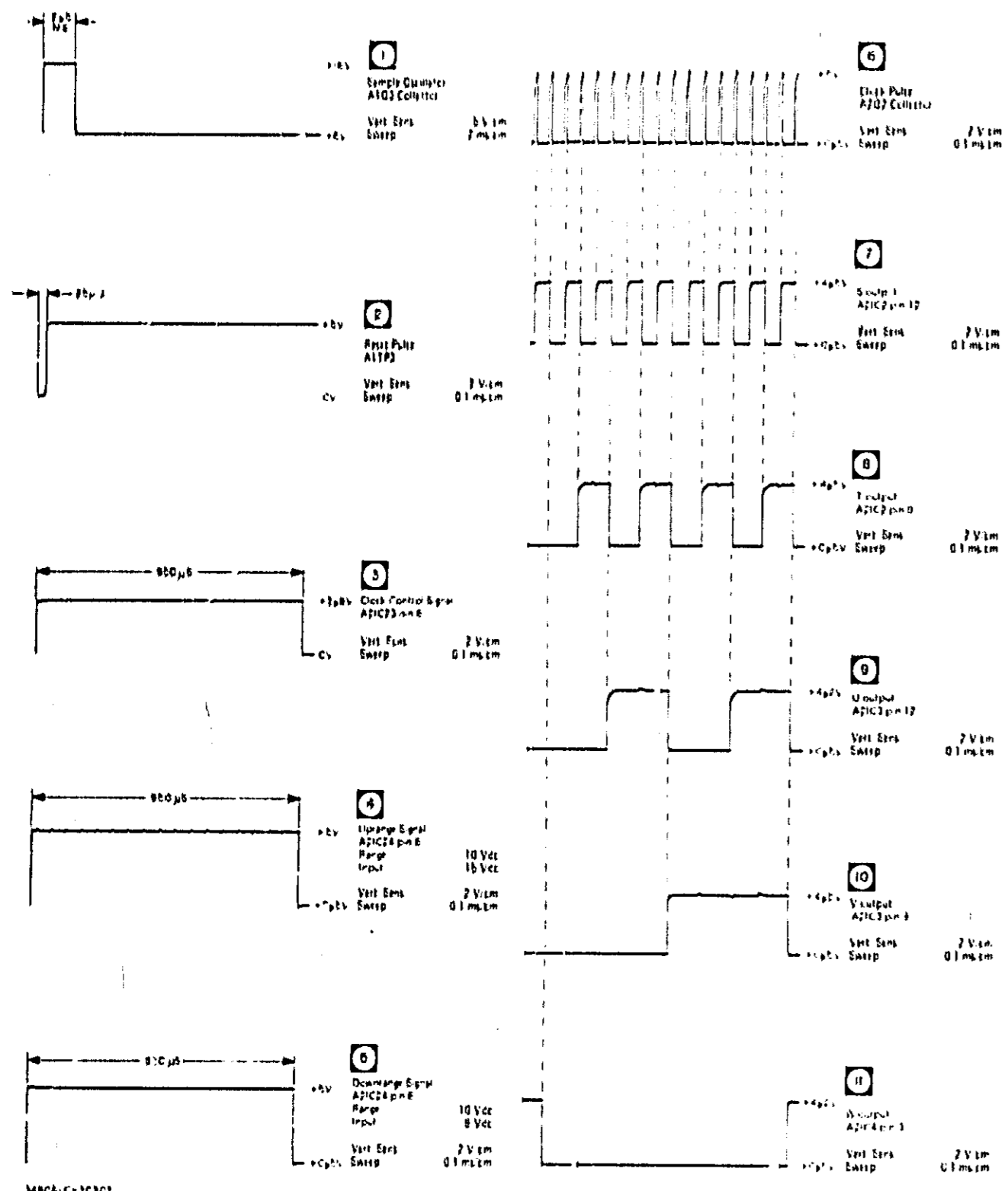
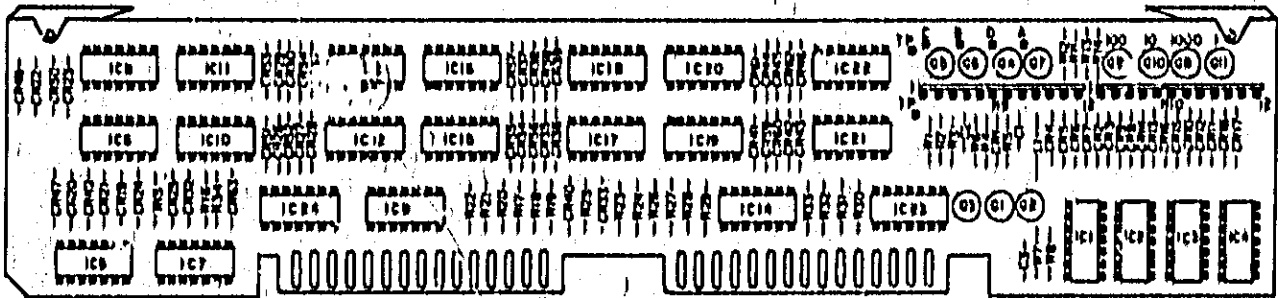

Figure 7-4, Waveforms.
7-6



A2
03480-66523-2

3480C/D-B-3462

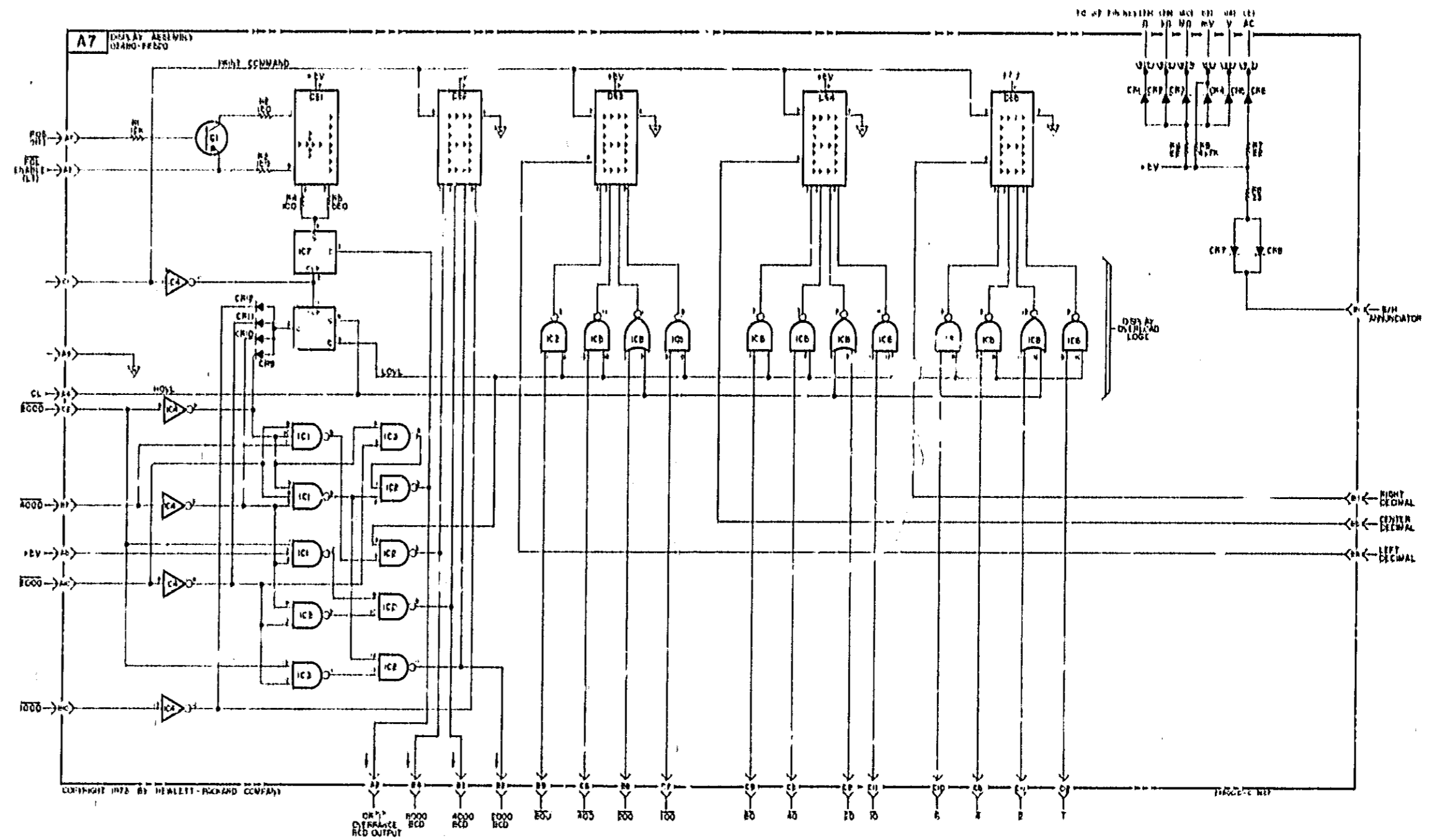
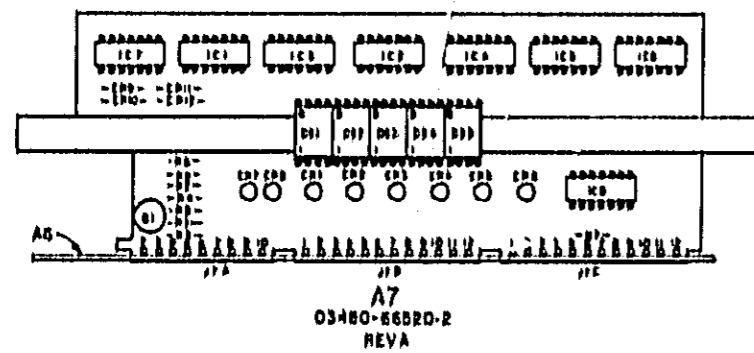
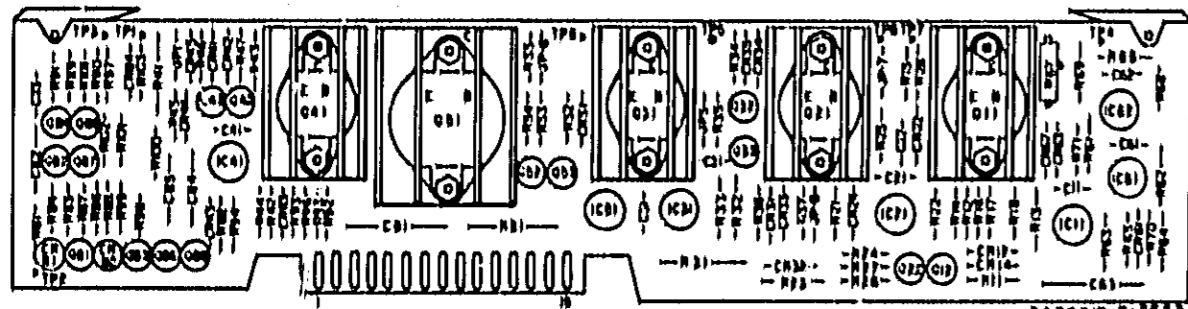
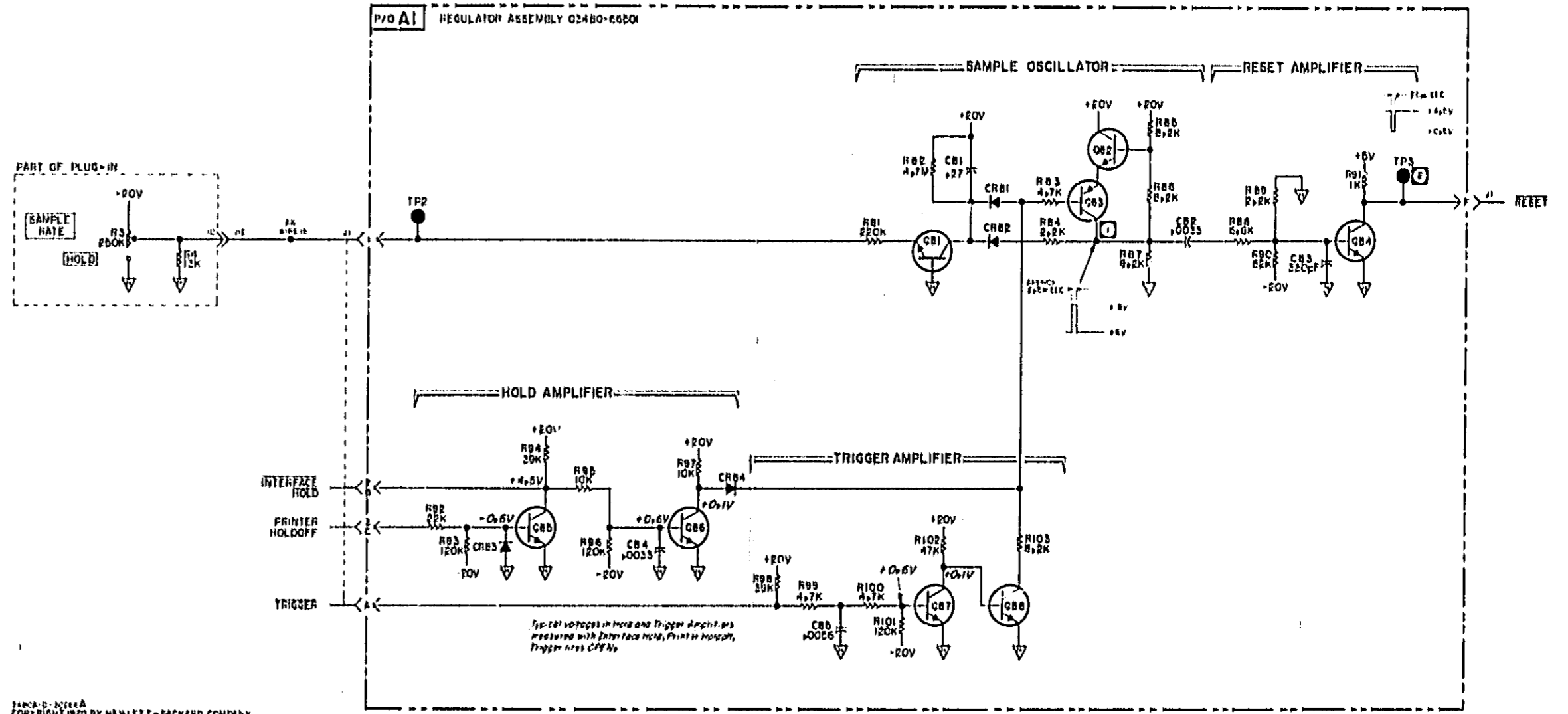

Figure 7-6. Schematic Diagram, Decoding and Annunciator Assembly, A7.



AI
03480-66621-2
REV A



3480C-D-3663A
COPYRIGHT 1970 BY HEWLETT-PACKARD COMPANY

Figure 7-7. Schematic Diagram, Sample Generator Circuits, AI.
7-11/7-12

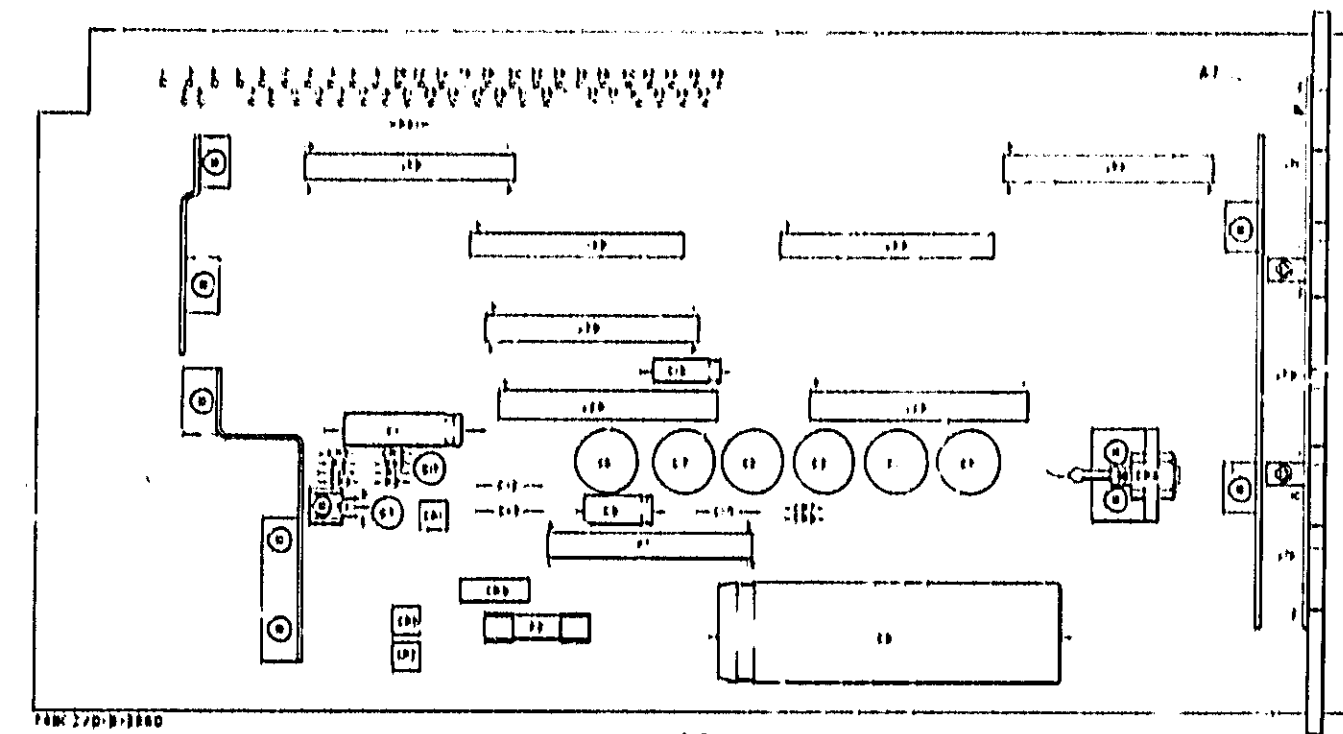

AG
03480-6622-2
REV A

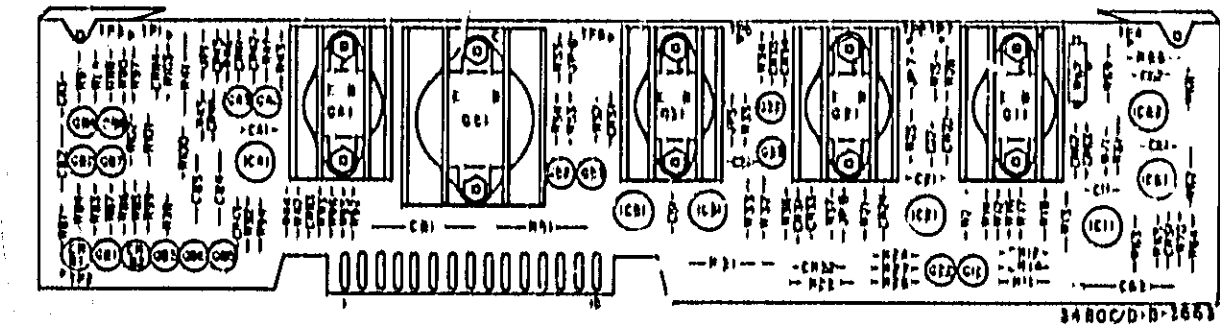

A1
03480-6621-2
REV A

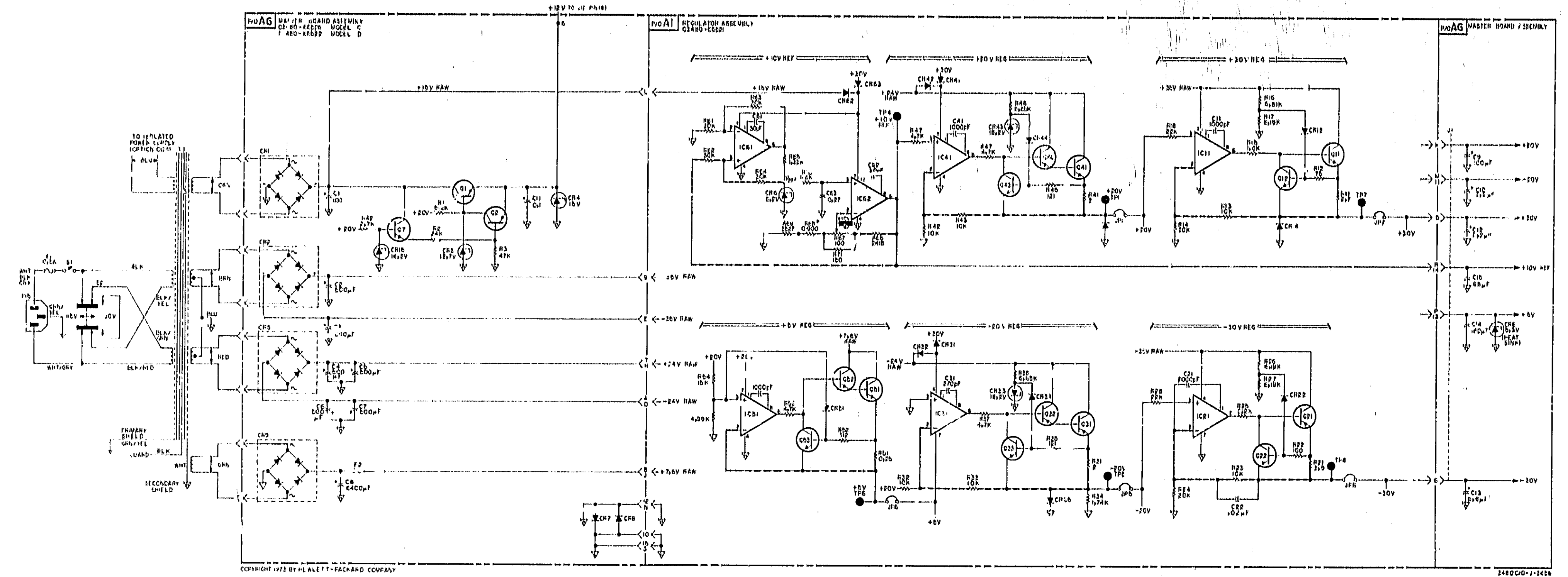
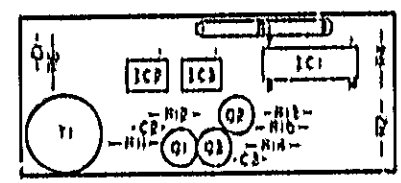
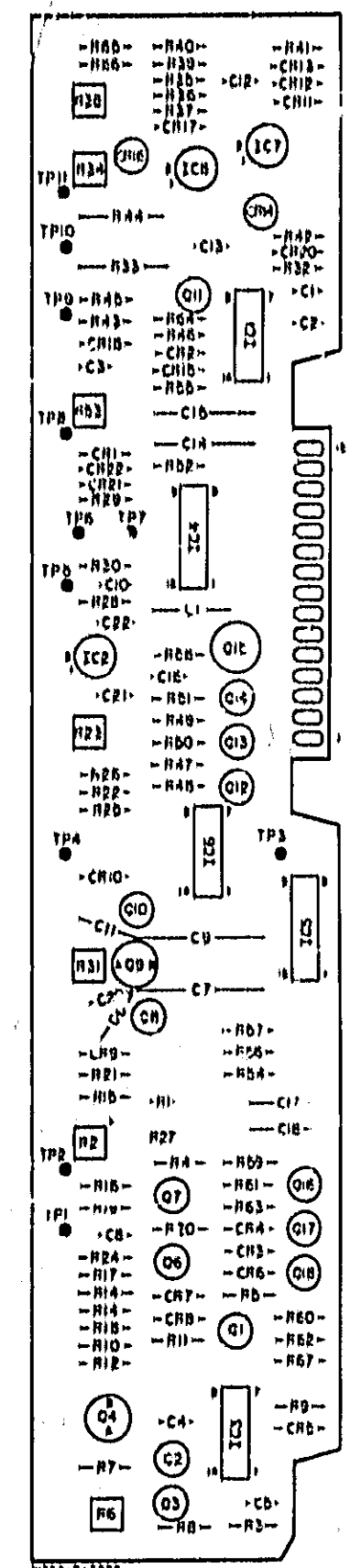
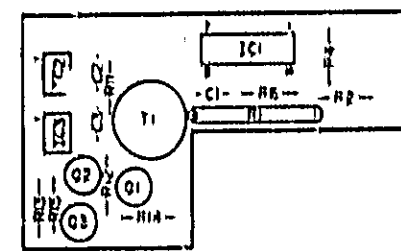

Figure 7-8. Schematic Diagram, Power Supplies A1 and A6.
7-137-14



A12
3480C
hp Part No. 11186-66502



A12
3480D
hp Part No. 11186-66503

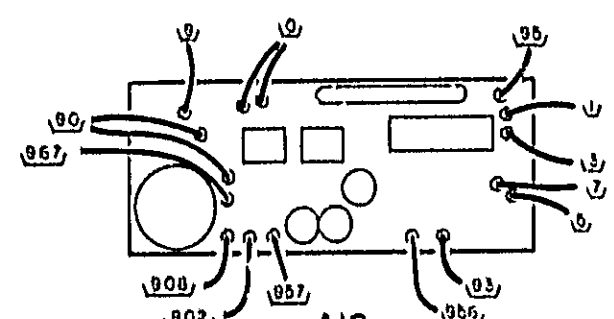

A12
3480C

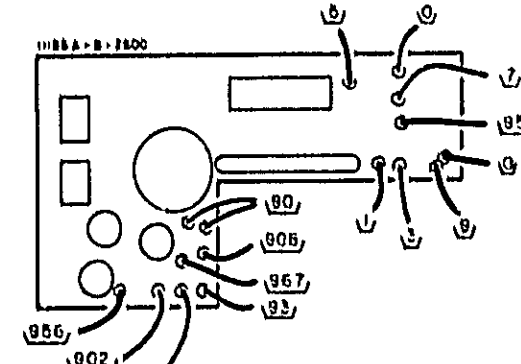

A12
3480D

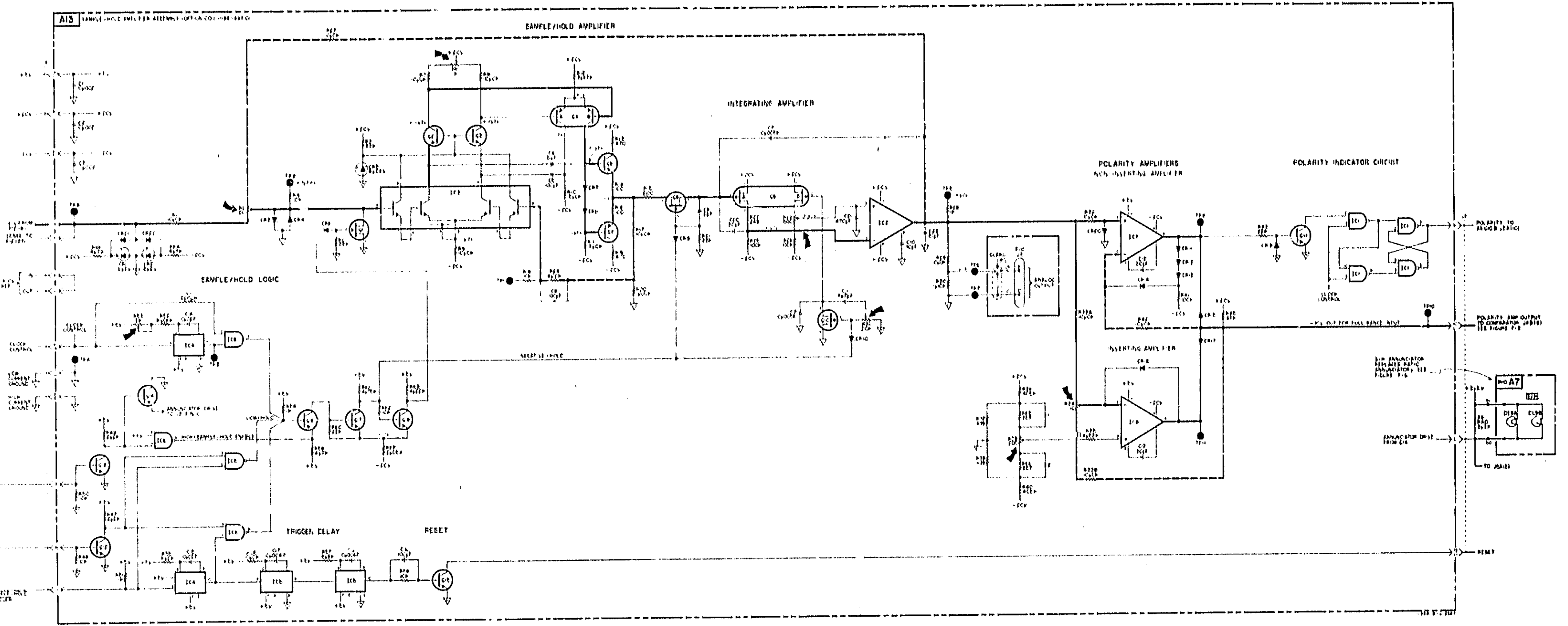
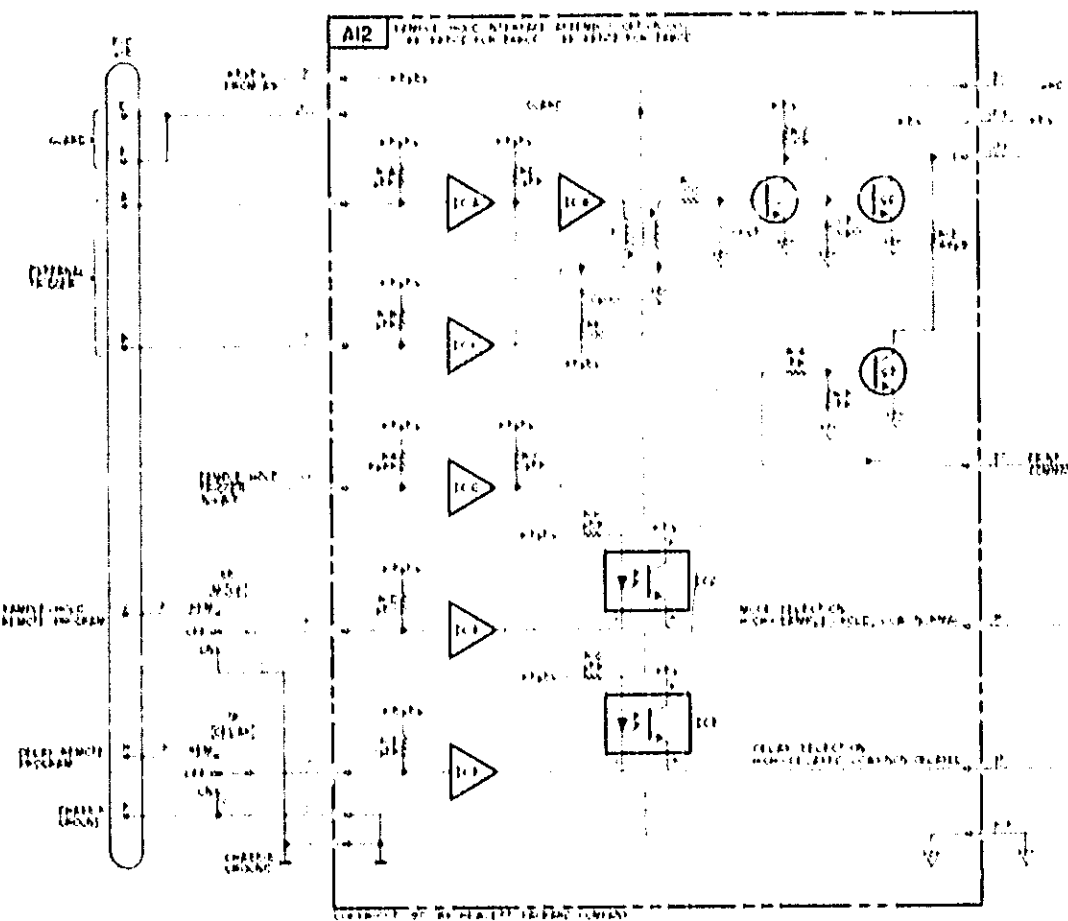
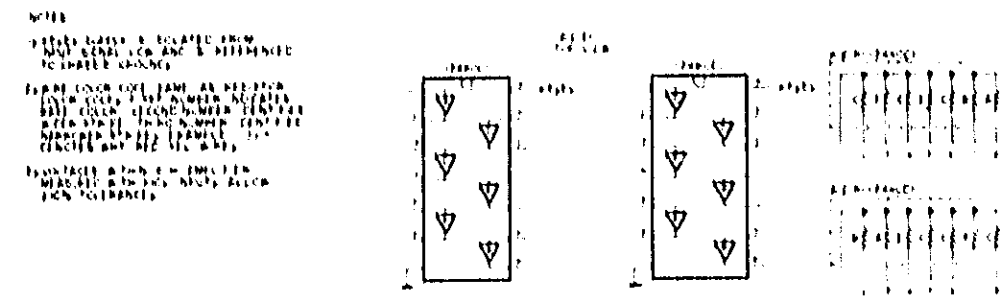

Figure 7-9. Schematic Diagram, Sample/Hold Option 001, A12, A13.

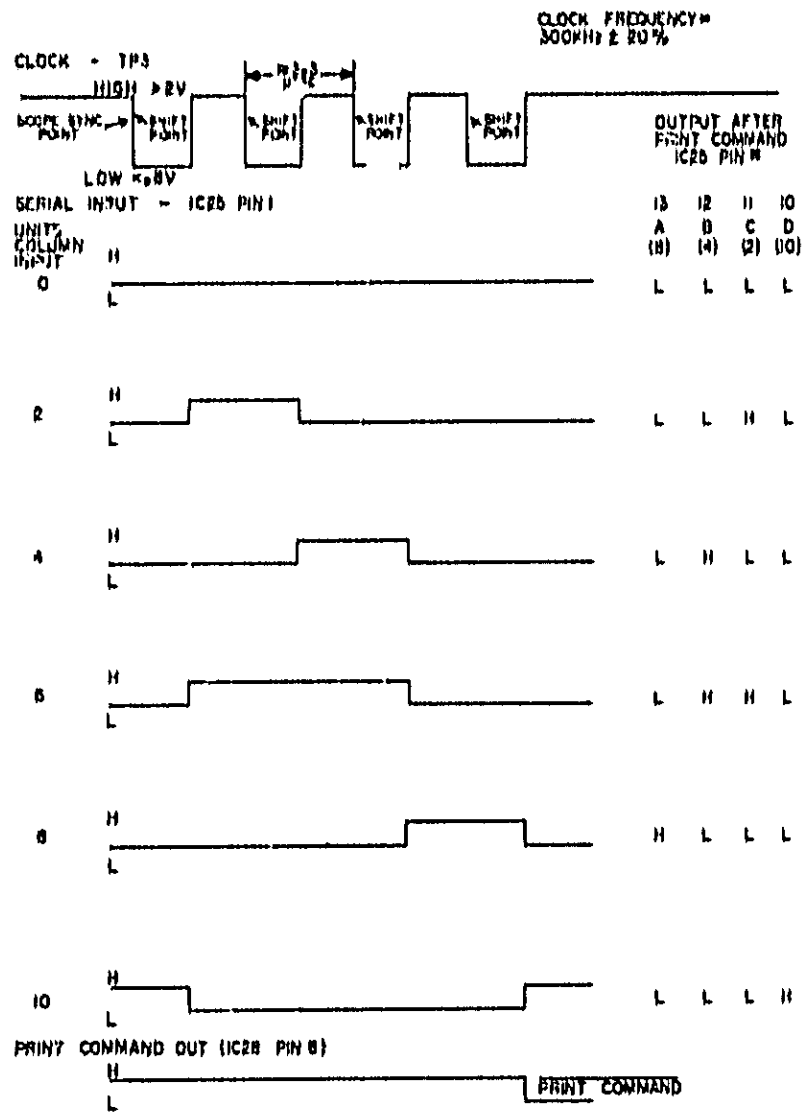
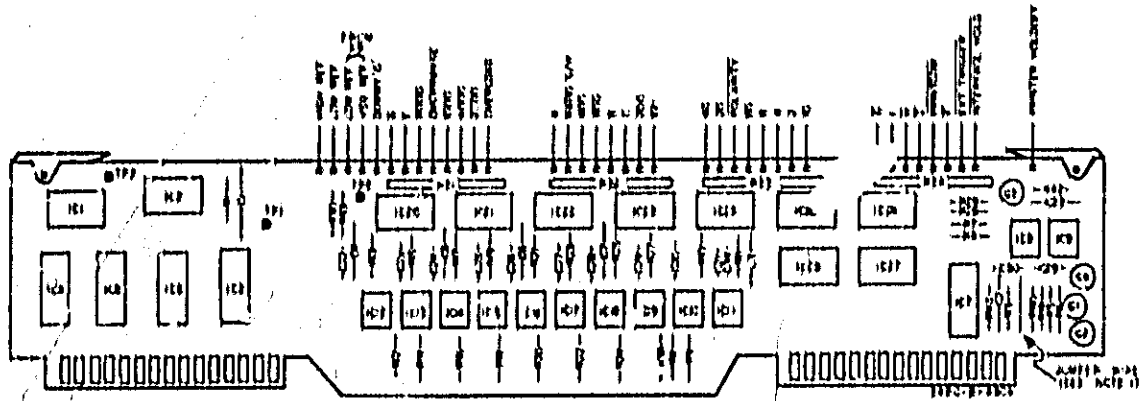

Figure 7-10. Units Shift Register Input.

NOTE 1

1 ohm resistors (part no. 8150-3375) may have been installed on jumpers at the factory. This part can be replaced using an insulated jumper wire.



A11

Hp Part No. 03480-66626

Rev. C

Table 1. Format for Option C04.

Plug-In Unit	Column									
	10	9	8	7	6	5	4	3	2	1
34E2A or 34B1A	---	Polarity and Overload	Function	Range	Data Overrange	Data Thousands	Data Hundreds	Data Tens	Data Units	---
34B5A	---	Polarity and Overload	Range	Scanner Channel Tens	Data Overrange	Data Thousands	Data Hundreds	Data Tens	Data Units	Scanner Channel Units

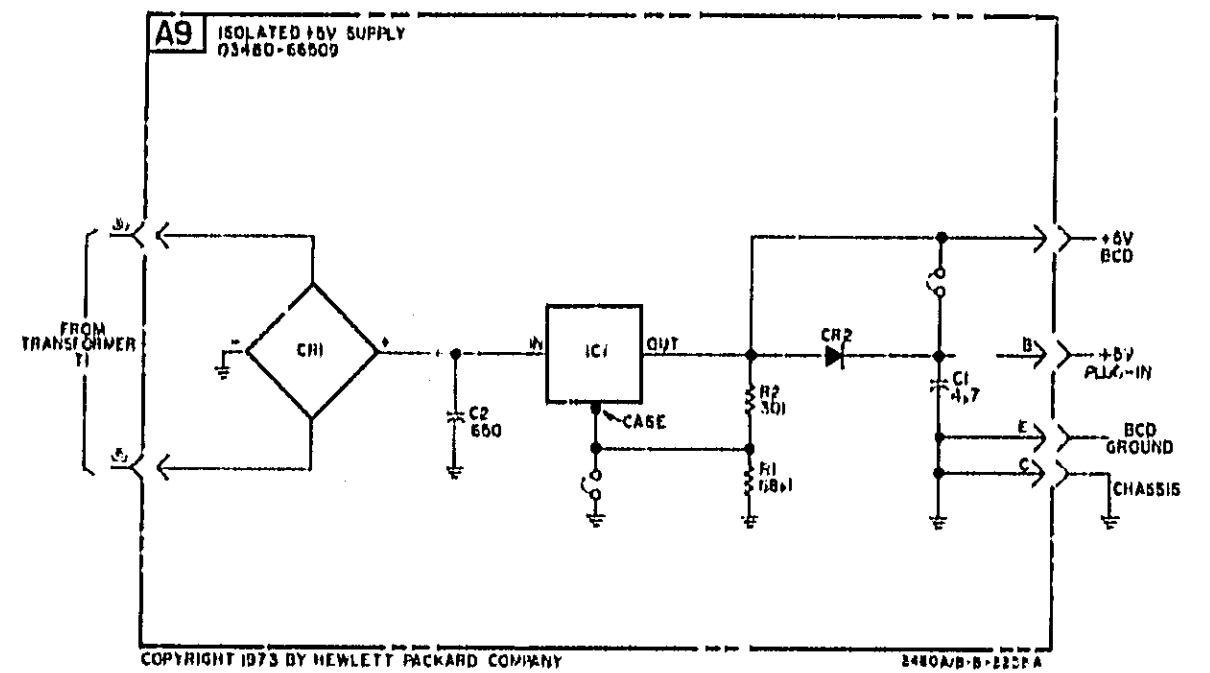
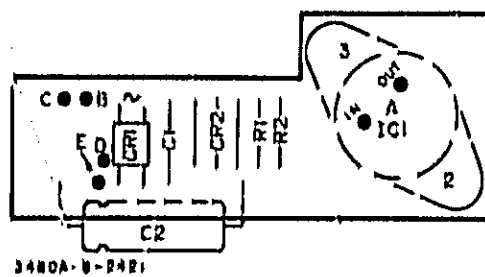

Figure 7-12. Schematic Diagram, Isolated Power Supply Assembly, A9.

Rev. A 7-21/7-22

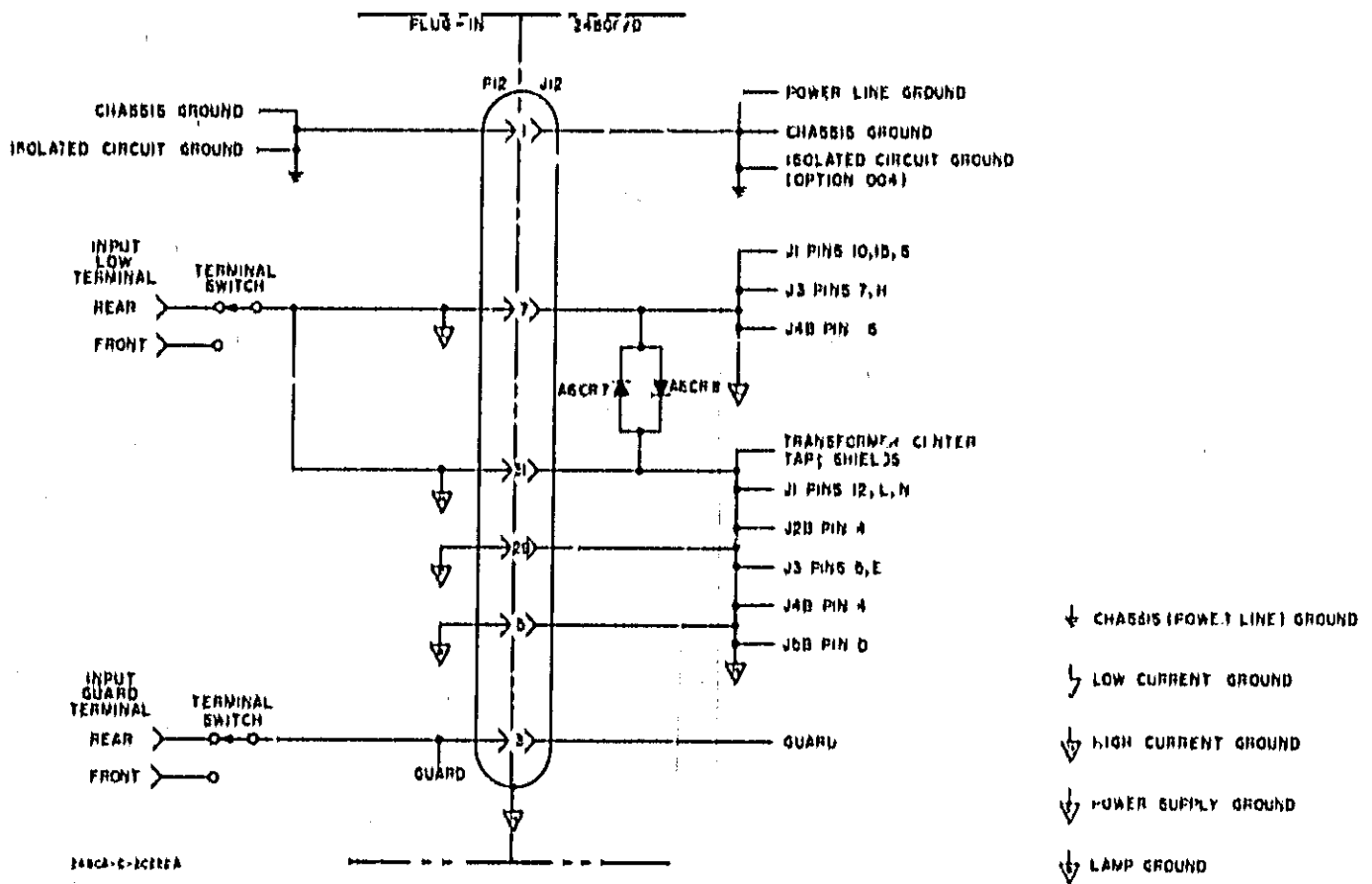

Figure 7-14. Ground Connections.

CODE LIST OF MANUFACTURERS

The following code numbers are from the Federal Supply Code for Manufacturers Cataloging Handbook (14-1) (Name in Code) and 14-1 (Code to Name) and their latest supplements. The date of revision and the date of the supplements used appear at the bottom of each page. Alphabetical codes have been arbitrarily assigned to suppliers not appearing in the 14-1 Handbook.

Code No.	Manufacturer	Address	Code No.	Manufacturer	Address	Code No.	Manufacturer	Address
00000	U. S. A. Common	Any supplier of U. S.	00347	Ultronic, Inc.	San Mateo, Cal.	11920	CTE of Byrne, Inc.	Byrne, Ind.
00136	McCoy Electronics	Mount Holly Springs, Pa.	00397	Union Carbide Corp., Electr.	Dly.	11927	Chicago Telephone of California, Inc.	So. Pasadena, Cal.
00137	Sage Electronics Corp.	Rochester, N. Y.	00571	Viking Ind. Inc.	Canoga Park, Cal.	11942	Dry State Electronics Corp.	Waltham, Mass.
00187	Cameco, Inc.	Danielson, Conn.	00593	Scorp Electro-Plastics Inc.	Sunnyside, Cal.	11948	Teledyne Inc., Microwave	Palo Alto, Cal.
00334	Micronia	Colton, Calif.	00618	Common Plastic (e. w. Electrical Appt. Co.)	Cleveland, Ohio	11974	National Sec.	Dowery, Cal.
00344	Micron, Co., Inc.	Valley Stream, N. Y.	00624	Barber Colman Co.	Rockford, Ill.	11463	Precision Connector Corp.	Tamara, N. Y.
00373	Garlock Inc.	Cherry Hill, N. J.	00728	Siffen Optical Co.	Brooklyn Heights, Long Island, N. Y.	11524	Duncan Electronics Inc.	Costa Mesa, Cal.
00394	Aerovox Corp.	New Bedford, Mass.	00789	Metro-Tel Corp.	Westbury, N. Y.	11711	General Instrument Corp., Semiconductor Division Products Group	Newark, N. J.
00479	Amp, Inc.	Harrisburg, Pa.	00789	Special Engineering Co.	Santa Cruz, Cal.	11717	Imperial Electronic, Inc.	Burns Park, Cal.
00481	Alcraft Radio Corp.	Houston, N. J.	00830	Wal' Field Engineering Inc.	Woburn, Mass.	11870	Mitaba, Inc.	Palo Alto, Cal.
00809	Crovet, Ltd.	Whitby, Ontario, Canada	00901	Warner Corp., Div. of Stewart Warner Corp.	Bridgeport, Conn.	11936	Philadelphia Handle Co.	Camden, N. J.
00816	Northern Engineering Laboratories, Inc.	Darlington, Wis.	04176	Hausch and Lomb Optical Co.	Rochester, N. Y.	11974	Gulton Ind. Inc., Data System Div.	Albuquerque, N. M.
00853	Bergamo Electric Co., Pickens Div.	Pickens, S. C.	04403	E. T. A. Products Co. of America	Chicago, Ill.	12007	Clarnat Mfg. Co.	Dover, N. H.
00866	Goe Engineering Co.	City of Industry, Cal.	04540	Amalton Electronic Hardware Co., Inc.	New Rochelle, N. Y.	12024	Elmer Filter Corp.	W. Haven, Conn.
00881	Carl K. Holmes Corp.	Los Angeles, Cal.	04555	Beers Electrical Instrument Co., Inc.	Peabody, N. H.	12029	Nippon Electric Co., Ltd.	Tokyo, Japan
00929	Microlab Inc.	Livingston, N. J.	06066	General Devices Co., Inc. Components Inc., Ariz. Div.	Phoenix, Arizona	12031	Delta Semiconductor Inc.	Newport Beach, Cal.
01003	General Electric Co., Capacitor Dept.	Judson Falls, N. Y.	06781	Wrington Mfg. Co., West Div.	Van Nuys, Cal.	12064	Wilson Electronics Corp.	Scottsdale, Arizona
01009	Aidin Products Co.	Rockton, Mass.	06880	Varian Assoc., Dimer Div.	San Carlos, Cal.	12091	Airco Supply Co., Inc.	Wichita, Kansas
01121	Allen Bradley Co.	Milwaukee, Wis.	07088	Kalvin Electric Co.	Van Nuys, Cal.	12091	Wilson Products	Detroit, Mich.
01265	Liton Industries, Inc.	Beverly Hills, Cal.	07128	Digital Co.	Pasadena, Cal.	12103	Thermolux	Dallas, Texas
01281	TW Sealconductors, Inc.	Lawndale, Cal.	07137	Translator Electronics Corp.	Minneapolis, Minn.	12387	Solliton Desires Inc.	Tappan, N. Y.
01295	Texas Instruments, Inc., Translator Products Div.	Dallas, Texas	07138	Westinghouse Electric Corp., Electron Tube Div.	Elmira, N. Y.	12388	Telefunken (Omni)	Hannover, Germany
01349	The Alliance Mfg. Co.	Alliance, Ohio	07149	Filmcorp	New York, N. Y.	12429	Midland-Wright Div. of Pacific Industries, Inc.	Kansas City, Kansas
01538	Small Parts Inc.	Los Angeles, Cal.	07233	Cinch-Graphic Co.	City of Industry, Cal.	12429	Sem-Tech	Newbury Park, Cal.
01548	Pacific Relays, Inc.	Van Nuys, Cal.	07256	Silicon Translator Corp.	Carle Place, N. Y.	12433	Calli Regulator Corp.	Santa Monica, Cal.
01570	Gudebrand Bros. Silk Co.	New York, N. Y.	07281	Avnet Corp.	Culver City, Cal.	12433	American Components, Inc.	Conshohocken, Pa.
01590	Aeroco Corp.	Rockford, Ill.	07283	Fairchild Camera & Inst. Corp., Semiconductor Div.	Mountain View, Cal.	14493	ITT Semiconductor, a Div. of Int. Telephone and Telegraph Corporation	West Palm Beach, Fla.
01590	Pulac Engineering Co.	Santa Clara, Cal.	07322	Minnesota Rubber Co.	Minneapolis, Minn.	14625	Hewlett-Packard Company	Los Angeles, Cal.
02134	Ferrycube Corp. of America	Saugerties, N. Y.	07327	Bircher Corp., The	Monterey Park, Cal.	14625	Cornell Dubilier Electric Corp.	Newark, N. J.
02116	Wheelock Signals, Inc.	Long Branch, N. J.	07397	Sylvania Elect. Prod. Inc., Mt. View Operations	Mountain View, Cal.	14674	Corning Glass Works	Corning, N. Y.
02286	Cole Rubber and Plastics Inc.	Sunnyside, Cal.	07700	Technical Wire Products Inc.	Cranford, N. J.	14752	Electro Cube Inc.	San Gabriel, Cal.
02660	Amphenol-Borg Electronics Corp.	Broadview, Ill.	07839	Bohne Elect. Co.	Chicago, Ill.	14880	Williams Mfg. Co.	San Jose, Cal.
02735	Radio Corp. of America, Semiconductor and Materials Division	Somerville, N. J.	07910	Continental Device Corp.	Hawthorne, Cal.	15106	The Sphere Co., Inc.	Little Falls, N. J.
02771	Vocaline Co. of America, Inc.	Old Saybrook, Conn.	07933	Raytheon Mfg. Co., Semiconductor Div.	Mountain View, Cal.	15202	Whelan Electronics Co.	New York, N. Y.
02777	Hopkins Engineering Co.	San Francisco, Cal.	07980	Hewlett-Packard Co., New Jersey Division	Rockaway, N. J.	15287	Ectonics Corp.	Northridge, Cal.
02816	Hudson Tool & Die	Newark, N. J.	08146	U. S. Engineering Co.	Los Angeles, Cal.	15291	Adjustable Batching Co.	N. Hollywood, Cal.
02826	Nylon Molding Corp.	Springfield, N. J.	08289	Hilton, Delbert Co.	Pomona, Cal.	15298	Mixon Electronics	Long Beach, Cal.
03008	G. E. Semiconductor Prod. Dept.	Syracuse, N. Y.	08358	Burgess Battery Co.	Niagara Falls, Ontario, Canada	15564	Amprobe Inst. Corp.	Lyndbrook, N. Y.
03705	Apex Machine & Tool Co.	Dayton, Ohio	08524	Deutch Fastener Corp.	Los Angeles, Cal.	15631	Cubotronics	Costa Mesa, Cal.
03787	Eldema Corp.	Compton, Calif.	08544	Bristol Co., The	Waterbury, Conn.	15712	Toshiba Corp. & Co. Spring Co.	Santa Clara, Cal.
03818	Parker Seal Co.	Los Angeles, Cal.	08717	Rioan Company	Sun Valley, Cal.	15801	Fernalt Elect. Inc.	Framingham, Mass.
03877	Transatron Electric Corp.	Woburn, Mass.	08718	ITT Cannon Electric Inc., Phoenix Div.	Phoenix, Arizona	15818	Americo Inc.	Mountain View, Cal.
03718	Pyrofilm Resistor Co., Inc.	Cedar Knolls, N. J.	08727	National Radio Lab. Inc.	Paramus, N. J.	16037	Spruce Pine Mfg. Co.	Spruce Pine, N. C.
03984	Singer Co., Diehl Div., Finderne Plant	Somerville, N. J.	08792	CDS Electronics Semiconductor Operations, Div. of CDS Inc.	Lowell, Mass.	16179	Omni-Spectra Inc.	Detroit, Ill.
04009	Arrow, Hart and Hegeman Elect. Co.	Hartford, Conn.	08806	General Electric Co., Miniature Lamp Dept.	Cleveland, Ohio	16352	Computer Diodo Corp.	Los, N. J.
04013	Tarus Corp.	Lambertville, N. J.	08984	Hal-Stain	Indianapolis, Ind.	16354	Electrad Co.	Union, N. J.
04062	Arco Electronic Inc.	Great Neck, N. Y.	09028	Babcock Relays Div.	Costa Mesa, Cal.	16385	Boots Aircraft Mfg. Corp.	Pasadena, Cal.
04217	Essex Wire	Los Angeles, Cal.	09097	Electronic Enclosures Inc.	Los Angeles, Calif.	16628	Ideal Prec. Mfg. Co., Inc.	Brooklyn, N. Y.
04222	H-Q Division of Aerovox	Myrtle Beach, S. C.	09134	Texas Capacitor Co.	Houston, Texas	16728	De Jur Meter Div.	Brooklyn, N. Y.
04354	Precision Paper Tube Co.	Wheeling, Ill.	09145	Elect. Ind. Inc. Alchem	Burbank, Cal.	16728	Delco Radio Div. of G. M. Corp.	Kokomo, Ind.
04404	Palo Alto Division of Hewlett-Packard Co.	Palo Alto, Cal.	09250	Electro Assemblies, Inc.	Chicago, Ill.	17109	Thermomats Inc.	Canoga Park, Cal.
04451	Sylvania Electric Products, Microwave Device Div.	Mountain View, Cal.	09363	C & K Components Inc.	Newton, Mass.	17174	Tranco Company	Mountain View, Cal.
04673	Dakota Ener, Inc.	Culver City, Cal.	09369	Mallory Battery Co. of Canada, Ltd.	Toronto, Ontario, Canada	17678	Hamlin Metal Products Corp.	Akron, Ohio
04713	Motorola Inc., Semiconductor Prod. Div.	Phoenix, Arizona	09384	Canada, Ltd.	Toronto, Ontario, Canada	17745	Angelstrom Prec. Inc.	No. Hollywood, Cal.
04772	Filltron Co., Inc. Western Div.	Culver City, Cal.	09522	Pennsylvania Fluorocarbon	Clifton Heights, Penn.	17856	Silicon Inc.	Sunnyside, Cal.
04773	Automatic Electric Co.	Northlake, Ill.	09522	Hurdy Corp.	Horswack, Conn.	17870	McGraw-Eaton Co.	Manchester, N. H.
04796	Sequela Wire Co.	Redwood City, Cal.	10214	General Translator Western Corp.	Los Angeles, Cal.	18042	Power Design Pacific Inc.	Palo Alto, Cal.
04811	Precision Coil Spring Co.	El Monte, Cal.	10214	General Translator Western Corp.	Los Angeles, Cal.	18083	Cleite Corp. Semiconductor Div.	Palo Alto, Cal.
04870	P. M. Motor Company	Westchester, Ill.	10214	General Translator Western Corp.	Los Angeles, Cal.	18324	Signetics Corp.	Sunnyside, Cal.
04818	Component Mfg. Service Co.	W. Bridgewater, Mass.	10214	General Translator Western Corp.	Los Angeles, Cal.	18476	Ty-Car Mfg. Co., Inc.	Holliston, Mass.
05096	Twentieth Century Plastics, Inc.	Los Angeles, Cal.	10214	General Translator Western Corp.	Los Angeles, Cal.	18486	TJW Elect. Comp. Div.	Des Plaines, Ill.
05277	Westinghouse Electric Corp., Semiconductor Dept.	Youngwood, Pa.	10214	General Translator Western Corp.	Los Angeles, Cal.	18565	Chomerics	Plainville, Mass.
			10214	General Translator Western Corp.	Los Angeles, Cal.	18583	Curtis Instrument, Inc.	Mt. Kisco, N. Y.
			10214	General Translator Western Corp.	Los Angeles, Cal.	18612	Vishay Instruments Inc.	Malvern, Pa.
			10214	General Translator Western Corp.	Los Angeles, Cal.	18673	E. J. DuPont and Co., Inc.	Wilmington, Del.
			10214	General Translator Western Corp.	Los Angeles, Cal.	18911	Durant Mfg. Co.	Milwaukee, Wis.
			10214	General Translator Western Corp.	Los Angeles, Cal.	19316	The Bendis Corp., Navigation & Control Div.	Teterboro, N. J.
			10214	General Translator Western Corp.	Los Angeles, Cal.	19500	Thomas A. Edison Industries, Div. of McGraw-Eaton	West Orange, N. J.
			10214	General Translator Western Corp.	Los Angeles, Cal.	19589	Concor	Baldwin Park, Cal.

00015-49
Revised: May, 1970

From Handbook Supplements
14-1 Dated January 1970

CODE LIST OF MANUFACTURERS (Continued)

Code No.	Manufacturer	Address	Code No.	Manufacturer	Address	Code No.	Manufacturer	Address
10244	I.H.C. Electronics	Horseshoe, N. Y.	71489	C. P. Clark & Co.	Chicago, Ill.	70482	Thompson-Downs & Co.	Chicago, Ill.
10245	Electra Mfg. Co.	Independence, Kansas	71490	Central Div. of Globe Union Inc.	Milwaukee, Wis.	70483	Tilly Mfg. Co.	San Francisco, Cal.
10246	General Altronics Corp.	Philadelphia, Pa.	71491	Commercial Machine Co.	Chicago, Ill.	70484	Stoppel Carbon Co.	St. Marys, Pa.
10247	Erculone, Inc.	Long Island City, N. Y.	71492	Cornell Wire Co., The	New York, N. Y.	70485	Standard Therman Corp.	Waltham, Mass.
10248	Fairly Heating Co., The	New Britain, Conn.	71493	Cuba Coil Co., Inc.	Princeton, N. J.	70486	Timmerman Products, Inc.	Cleveland, Ohio
10249	Fairchild Metallurgical Corp.	N. Chicago, Ill.	71494	Chicago Miniature Lamp Works	Chicago, Ill.	70487	Translucor Engineers	San Gabriel, Cal.
10250	General Ford Co.	Metuchen, N. J.	71495	Cinch Mfg. Co.	Chicago, Ill.	70488	Uphite Co.	Northville, Mass.
10251	Taboran Corp.	Indianapolis, Ind.	71496	Howard H. Jones Div.	Chicago, Ill.	70489	Walden Rubber Inc.	Long Island City, N. Y.
10252	British Radio Electronics Ltd.	Washington, D.C.	71497	Dow Corning Corp.	Midland, Mich.	70490	Wesley Tech. Inc.	Hartford, Conn.
10253	G. E. Lamp Division, Mela Park	Cleveland, Ohio	71498	Electro Motive Mfg. Co., Inc.	Willmantle, Conn.	70491	Werns Mfg. Co.	Chicago, Ill.
10254	General Radio Co.	West Concord, Mass.	71499	Diagraph Corp.	Brooklyn, N. Y.	70492	Zircon Mfg. Corp.	New Rochelle, N. Y.
10255	Memmor Inc., Comp. Div.	Huntington, Ind.	71500	Indiana General Corp.	Keasby, N. J.	70493	Myron Division of Seaboard Clark Co.	Myrtle Beach, S. C.
10256	Optica Reproducer Corp.	New Rochelle, N. Y.	71501	Electrotherm Div.	Keasby, N. J.	70494	General Instrument Corp.	Keasby, N. J.
10257	Robert File Co. of America, Inc.	Carlsbad, N. J.	71502	Cap Division	Keasby, N. J.	70495	Cap Division	Keasby, N. J.
10258	Comper-Hollister Co.	Hollister, Cal.	71503	Drake Mfg. Co.	Harrisburg, Pa.	70496	Drake Mfg. Co.	Harrisburg, Pa.
10259	Hamilton Watch Co.	Lansdale, Pa.	71504	Hugh H. Eby Inc.	Philadelphia, Pa.	70497	Electron Industrial Association	Standard Code of semi-conductor device manufacturers
10260	Hewlett-Packard Co.	Palo Alto, Cal.	71505	Goodman Co.	Chicago, Ill.	70498	United Transformer Corp.	Massachusetts
10261	Hoyman Mfg. Co.	Kentworth, N. J.	71506	Elcotic Ray Bulb Corp.	Union, N. J.	70499	United Transformer Corp.	Massachusetts
10262	Instrument Specialties Co., Inc.	Little Falls, N. J.	71507	Hubert M. Hadley Co.	Los Angeles, Cal.	70500	United Transformer Corp.	Massachusetts
10263	G. E. Heating Tube Dept.	Schenectady, N. Y.	71508	Eric Technological Products, Inc.	Elizabethtown, N. J.	70501	United Transformer Corp.	Massachusetts
10264	Kerrison Inc.	Chicago, Ill.	71509	Jensen Mfg. Co., Inc.	Princeton, Ind.	70502	United Transformer Corp.	Massachusetts
10265	Sanaych Coal Products, Ltd.	Hawkesbury, Ontario, Canada	71510	H. M. Harper Co.	Chicago, Ill.	70503	United Transformer Corp.	Massachusetts
10266	Cunningham, W. H. & Hill, Ltd.	Toronto, Ontario, Canada	71511	Heliport Div. of Berkman Int'l., Inc.	Fullerton, Cal.	70504	United Transformer Corp.	Massachusetts
10267	P. H. Mallory & Co., Inc.	Indianapolis, Ind.	71512	Hughes Products Division of Hughes Aircraft Co.	Newport Beach, Cal.	70505	United Transformer Corp.	Massachusetts
10268	Mechanical Industries Prod. Co.	Akron, Ohio	71513	Amperek Elect. Co.	Hicksville, L. I., N. Y.	70506	United Transformer Corp.	Massachusetts
10269	Miniature Precision Bearings, Inc.	Kyne, N. H.	71514	Bradley Semiconductor Corp.	New Haven, Conn.	70507	United Transformer Corp.	Massachusetts
10270	Honeywell Inc.	Minneapolis, Minn.	71515	Carlisle Electric, Inc.	Hartford, Conn.	70508	United Transformer Corp.	Massachusetts
10271	Muter Co.	Chicago, Ill.	71516	Circle F Mfg. Co.	Trenton, N. J.	70509	United Transformer Corp.	Massachusetts
10272	C. A. Nutzen Co.	Englewood, Colo.	71517	George K. Herritt Co., Div. M.E.I. Industries, Inc.	Philadelphia, Pa.	70510	United Transformer Corp.	Massachusetts
10273	Ohmite Mfg. Co.	Shkup, Ill.	71518	Federal Screw Products, Inc.	Chicago, Ill.	70511	United Transformer Corp.	Massachusetts
10274	Penn Eng. & Mfg. Corp.	Douglas, Pa.	71519	Fisher Special Mfg. Co.	Cincinnati, Ohio	70512	United Transformer Corp.	Massachusetts
10275	Polaroid Corp.	Cambridge, Mass.	71520	General Industries Co., The	Elizabethtown, N. J.	70513	United Transformer Corp.	Massachusetts
10276	Praxair Thermometer & Intl. Co.	Southampton, Pa.	71521	Goshen Sampling & Tool Co.	Goshen, Ind.	70514	United Transformer Corp.	Massachusetts
10277	Microwave & Power Tube Div.	Waltham, Mass.	71522	JFD Electronics Corp.	Brooklyn, N. Y.	70515	United Transformer Corp.	Massachusetts
10278	Moran Controller Co.	Westminster, Md.	71523	Jennings Radio Mfg. Corp.	San Jose, Cal.	70516	United Transformer Corp.	Massachusetts
10279	LLP Co., Med. Elec. Div.	Waltham, Mass.	71524	Graves-Pin Corp.	Ridgely, N. J.	70517	United Transformer Corp.	Massachusetts
10280	Shelburne Mfg. Co.	Selma, N. C.	71525	Signalite Inc.	Springe, N. J.	70518	United Transformer Corp.	Massachusetts
10281	Siemans Electric Co.	Chicago, Ill.	71526	J. H. Wines and Sons	Winchester, Mass.	70519	United Transformer Corp.	Massachusetts
10282	Somnolone Corp.	Elmford, N. Y.	71527	Industrial Condenser Corp.	Chicago, Ill.	70520	United Transformer Corp.	Massachusetts
10283	Raytheon Co. Commercial Apparatus & System Div.	Bo. Norwalk, Conn.	71528	H. F. Products Division of Amphent-Borg Electronic Corp.	Danbury, Conn.	70521	United Transformer Corp.	Massachusetts
10284	Equalizing Filter Co., Inc.	Tonawanda, N. Y.	71529	E. F. Johnson Co.	Waukegan, Minn.	70522	United Transformer Corp.	Massachusetts
10285	Sarasop Electric Co.	North Andam, Mass.	71530	International Resistance Co.	Philadelphia, Pa.	70523	United Transformer Corp.	Massachusetts
10286	Superior Elect. Co.	Bristol, Conn.	71531	Keystone Carbon Co., Inc.	St. Marys, Pa.	70524	United Transformer Corp.	Massachusetts
10287	Telex Corp.	T. V., Ohio	71532	CTS Night, Inc.	Sandwich, Ill.	70525	United Transformer Corp.	Massachusetts
10288	Thomas & Betts Co.	Elletts, N. J.	71533	Kulka Electric Corp.	Mt. Vernon, N. Y.	70526	United Transformer Corp.	Massachusetts
10289	Trippitt Electrical Intl. Co.	Mullton, Ohio	71534	Lenz Electric Mfg. Co.	Chicago, Ill.	70527	United Transformer Corp.	Massachusetts
10290	Union Switch and Signal Div. of Westinghouse Air Brake Co.	Pittsburgh, Pa.	71535	Lillymeyer, Inc.	Des Plaines, Ill.	70528	United Transformer Corp.	Massachusetts
10291	Universal Electric Co.	Onondaga, Mich.	71536	Lord Mfg. Co.	Elizabethtown, N. J.	70529	United Transformer Corp.	Massachusetts
10292	Ward-Leonard Electric Co.	Mt. Vernon, N. Y.	71537	C. W. Marzetti	San Francisco, Cal.	70530	United Transformer Corp.	Massachusetts
10293	Western Electric Inc.	New York, N. Y.	71538	Micramid Instrument Corp.	Newark, N. J.	70531	United Transformer Corp.	Massachusetts
10294	Western Intl. Inc.	Weston-Newark, Newark, N. J.	71539	James Miller Mfg. Co., Inc.	Malden, Mass.	70532	United Transformer Corp.	Massachusetts
10295	Wiltek Mfg. Co.	Chicago, Ill.	71540	J. A. Miller Co.	Los Angeles, Cal.	70533	United Transformer Corp.	Massachusetts
10296	Minnesota Mining & Mfg. Co. Reserve Mining Div.	St. Paul, Minn.	71541	Cinch-Monotack, Div. of United Corp.	San Leandro, Cal.	70534	United Transformer Corp.	Massachusetts
10297	Allen Mfg. Co.	Hartford, Conn.	71542	Fastener Corp.	Cleveland, Ohio	70535	United Transformer Corp.	Massachusetts
10298	Allied Control	New York, N. Y.	71543	Muller Electric Co.	Cleveland, Ohio	70536	United Transformer Corp.	Massachusetts
10299	Allmetal Sprogs Product Co., Inc.	Garden City, N. Y.	71544	National Union	Newark, N. J.	70537	United Transformer Corp.	Massachusetts
10300	Amplex, Div. of Chrysler Corp.	Detroit, Mich.	71545	Oak Manufacturing Co.	Crystal Lake, Ill.	70538	United Transformer Corp.	Massachusetts
10301	Atlantic India Rubber Works, Inc.	Chicago, Ill.	71546	The Bendix Corp.	Flint, Mich.	70539	United Transformer Corp.	Massachusetts
10302	Amperite Co., Inc.	Union City, N. J.	71547	Electrodynamics Div.	H. Hollywood, Cal.	70540	United Transformer Corp.	Massachusetts
10303	ADC Products Inc.	Minneapolis, Minn.	71548	Parille Metals Co.	San Francisco, Cal.	70541	United Transformer Corp.	Massachusetts
10304	Belden Mfg. Co.	Chicago, Ill.	71549	Phostran Instrument and Electronic Co.	So. Pasadena, Cal.	70542	United Transformer Corp.	Massachusetts
10305	Bird Electric Corp.	Cleveland, Ohio	71550	Philadelphian Steel and Wire Corp.	Philadelphia, Pa.	70543	United Transformer Corp.	Massachusetts
10306	Bjornbich Radio Co.	New York, N. Y.	71551	American Machine & Foundry Co.	Princeton, Ind.	70544	United Transformer Corp.	Massachusetts
10307	Biley Electric Co., Inc.	Elizabethtown, N. J.	71552	Phillips & Springfield Div.	Camden, N. J.	70545	United Transformer Corp.	Massachusetts
10308	Boston Gear Works Div. of Murray Co. of Trask	Quincy, Mass.	71553	Rechtler Division	Brooklyn, N. Y.	70546	United Transformer Corp.	Massachusetts
10309	Bud Radio, Inc.	Willoughby, Ohio	71554	Resistance Products Co.	Harrisburg, Pa.	70547	United Transformer Corp.	Massachusetts
10310	Cambridge Thermionics Corp.	Cambridge, Mass.	71555	Rubbercraft Corp. of Calif.	Torrance, Cal.	70548	United Transformer Corp.	Massachusetts
10311	Camloc Fastener Corp.	Paramus, N. J.	71556	Shakaport Division of Illinois Tool Works	Elgin, Ill.	70549	United Transformer Corp.	Massachusetts
10312	Cardwell Condenser Corp.	Lindenhurst, L. I., N. Y.	71557	Sigma	So. Braintree, Mass.	70550	United Transformer Corp.	Massachusetts
10313	Deere Mfg. Div. of Ingersoll Rand	St. Louis, Mo.	71558	Signal Indicator Corp.	New York, N. Y.	70551	United Transformer Corp.	Massachusetts
10314	Chicago Condenser Corp.	Chicago, Ill.	71559	Smith-Dunn Inc.	Pitman, N. J.	70552	United Transformer Corp.	Massachusetts
10315	Calif. Spring Co., Inc.	Pico-Rivera, Cal.	71560	Stentor Corp.	Chicago, Ill.	70553	United Transformer Corp.	Massachusetts
10316	CG Corp.	Elkhart, Ind.	71561	Stentor Corp.	Chicago, Ill.	70554	United Transformer Corp.	Massachusetts
10317	ITT Cannon Electric Inc.	Los Angeles, Cal.	71562	Stentor Corp.	Chicago, Ill.	70555	United Transformer Corp.	Massachusetts
10318	Cinema Div. of Technicon Corp.	Burlingame, Cal.	71563	Stentor Corp.	Chicago, Ill.	70556	United Transformer Corp.	Massachusetts

CODE LIST OF MANUFACTURERS (Continued)

Code No.	Manufacturer	Address	Code No.	Manufacturer	Address	Code No.	Manufacturer	Address
91870	Barbara Tarran, Inc.	Alhambra, Ind.	91899	Honeywell Inc., Mixed Switch Division	Freeport, Ill.	92095	H-42 Div. of Avon Corp.	Olean, N. Y.
91871	Boston Molding Company	Boston, N. J.	91901	Nashville, Spring Co.	Oakland, Cal.	92096	Thorndarson-Melander Inc.	Mt. Carmel, Ill.
91872	A. B. Boyd Co.	San Francisco, Cal.	91902	Tru-Connector Corp.	Peabody, Mass.	92097	Solar Mfg. Co.	Los Angeles, Cal.
91873	H. M. Brammick & Co.	San Francisco, Cal.	91903	Elmer Optical Co., Inc.	Rochester, N. Y.	92098	Microwatch, Div. of	Freeport, Ill.
91874	Hollis Borden, Inc.	Holland, Conn.	91904	JMC Magnetics Corp.	Westbury, L. I., N. Y.	92099	Carlson Screw Co.	Chicago, Ill.
91875	Beaumont Rubber Co.	Chicago, Ill.	91905	Hudson Lamp Co.	Mearney, N. J.	92100	Microwave Associates, Inc.	Burlington, Mass.
91876	Palmer Heating Co.	Los Angeles, Calif.	91906	Sylvania Electric Prod. Inc., Semiconductor Div.	Woburn, Mass.	92101	Erel Transformer Co.	Oakland, Cal.
91877	Clifton Precision Products Co., Inc.	Clifton Heights, Pa.	91907	Hobbs & Myers Inc.	Palladium Park, N. J.	92102	Krellite, Inc.	Orchard Park, N. Y.
92079	Precision Rubber Products Corp.	Dallas, Ohio	91908	Belmont Controls, Div. of Essex Wire Corp.	Massillon, Ohio	92103	San Fernando Elec. Mfg. Co.	San Fernando, Cal.
92080	Radio Corp. of America, Electronic Corp. & Dept. of Division	Harrison, N. J.	91909	Waters Mfg. Co.	Culver City, Cal.	92104	Thomson Ind. Inc.	Long Island, N. Y.
92081	Teatron Mfg. Co.	Olivdale, Cal.	91910	G. V. Controls	Lititz, Pa.	92105	Industrial Retaining Ring Co.	Irvington, N. J.
92082	Marjo Industries	Anaheim, Cal.	91911	Haytheon Co., Comp. Div., Ind. Comp. Division	San Jose, N. J.	92106	Automatic & Precision Mfg.	Englewood, N. J.
92083	Phileo Corporation (Lanadale Division)	Lanadale, Pa.	91912	Kelvinite Electronics Products, Inc.	Loveland, Colo.	92107	Bron Heatator Corp.	Yonkers, N. Y.
92084	Western Fibre Glass Products Co.	San Francisco, Cal.	91913	Wagner Elect. Corp.	Newark, N. J.	92108	Lillian System Inc., Adler-Wentz Company, Div.	New Rochelle, N. Y.
92085	Van Wazer & Rogers Inc.	San Francisco, Cal.	91914	Tung-Sol Div.	East Pittsford, N. J.	92109	H-Tronics, Inc.	Jamaica, N. Y.
92086	Tower Mfg. Corp.	Princeton, N. J.	91915	Carlin-Wright Corp., Electronics Div.	East Pittsford, N. J.	92110	Hulder Tech, Inc.	Gardens, Cal.
92087	Culler-Hammer, Inc.	Lincoln, Ill.	91916	South Chasler Corp.	Chasler, Pa.	92111	Hewlett-Packard Co., Medical Elec. Div.	Pasadena, Cal.
92088	Gold-National Batteries, Inc.	St. Paul, Minn.	91917	Wire Cloth Products, Inc.	Lititz, Pa.	92112	Mirrol Inc.	So. Pasadena, Cal.
92089	General Mills, Inc.	Duluth, N. Y.	91918	Automatic Metal Products Co.	Brooklyn, N. Y.	92113	Seal Corp.	Mamaroneck, N. Y.
92090	Crybar Electric Co.	Oakland, Cal.	91919	Waterfall Pressed Aluminum Co.	Waterfall, Mass.	92114	Zero Mfg. Co.	Barbours, Cal.
92091	G. E. Distributing Corp.	Schenectady, N. Y.	91920	Magnetron Electric Co.	Chicago, Ill.	92115	Etc. Inc.	Cleveland, Ohio
92092	Security Co.	Delroit, Mich.	91921	George A. Philbrick Researches, Inc.	Boston, Mass.	92116	General Mills Inc., Electronics Div.	Minneapolis, Minn.
92093	United Transformer Co.	Chicago, Ill.	91922	Alco Elect. Mfg. Co.	Lawrence, Mass.	92117	Perry Division of Hewlett-Packard Co.	Palo Alto, Cal.
92094	United Shoe Machinery Corp.	Needham, Mass.	91923	Allied Products Corp.	Dunwoody, Ga.	92118	Smith-Mills Electronics, Inc.	Glen Cove, N. Y.
92095	U. S. Rubber Co., Consumer Ind. & Plastic Prod. Div.	Passaic, N. J.	91924	Cosmical Connector Corp.	Woodside, N. Y.	92119	International Electronic Research Corp.	Barbours, Cal.
92096	Holleyville Speciality Tool Mfg., Inc.	Holleyville, Ill.	91925	Lenscraft Mfg. Co., Inc.	Long Island, N. Y.	92120	Columbia Technical Corp.	New York, N. Y.
92097	United Carr Fastener Corp.	Chicago, Ill.	91926	National Coil Co.	Berkeley, Ky.	92121	Varian Associates	Palo Alto, Cal.
92098	Bearing Engineering Co.	San Francisco, Cal.	91927	Vibratum, Inc.	Bridgeport, Conn.	92122	Altra Corp.	Winchester, Mass.
92099	ITT Cannon Elect. Inc.	Salem, Mass.	91928	Corbin Corp.	Bloomfield, N. J.	92123	Marshall Ind., Capacitor Div.	Mesquite, Cal.
92100	Connor Spring Mfg. Co.	San Francisco, Cal.	91929	Arnold Engineering Co.	Marygrove, Ill.	92124	Control Switch Division, Controls Co. of America	Escondido, Cal.
92101	Miller Dial & Nameplate Co.	El Monte, Cal.	91930	Page Electric Co., Inc.	Franklin, Ind.	92125	Delevan Electronics Corp.	East Aurora, N. Y.
92102	Radio Material Co.	Chicago, Ill.	91931	Wesbecker Co.	Chicago, Ill.	92126	Wilco Corporation	Indianapolis, Ind.
92103	Aural Inc.	Allabro, Mass.	91932	Microwave Assoc., West. Div.	Bunnysville, Cal.	92127	Orwash Corp.	Whippany, N. J.
92104	Dale Electronics, Inc.	Columbus, Miss.	91933	Micro-42 Div. of Avon Corp.	Olean, N. Y.	92128	Hambrant, Inc.	Boston, Mass.
92105	Elco Corp.	Willow Grove, Pa.	91934	Thorndarson-Melander Inc.	Mt. Carmel, Ill.	92129	Huffman Electronics Corp., Semiconductor Division	El Monte, Cal.
92106	Epiphone Inc.	New York, N. Y.	91935	Solar Mfg. Co.	Los Angeles, Cal.	92130	Technology Instrument Corp. of California	Newbury Park, Cal.
92107	Greiner Mfg. Co., Inc.	Wakarusa, Mass.	91936	Honeywell Inc., Mixed Switch Division	Freeport, Ill.			
92108	K F Development Co.	Hedden City, Cal.	91937	Nashville, Spring Co.	Oakland, Cal.			
92109	Malco Mfg., Inc.	Chicago, Ill.	91938	Tru-Connector Corp.	Peabody, Mass.			

The following list of vendors have no number assigned in the latest supplement to the Federal Supply Code for Manufacturers Handbook.

00001	Metal Tool and Die	Los Angeles, Calif.	00008	Hewlett-Packard Co.	Palo Alto, Cal.	00043	Coiltron	Oakland, Cal.
00002	Willow Leather Products Corp.	Newark, N. J.	00009	Spring Div.	Colorado Springs, Colorado	00044	California Eastern Lab.	Burlington, Cal.
00003	ETA	England	00010	Auther Eng. & Development	Hajya J. Cal.	00045	B. K. Smith Co.	Los Angeles, Cal.
00004	Precision Instrument Comp. Co.	Van Nuys, Cal.	00011	A "N" Mfg. Co.	San Jose, Cal.			

SERVICE NOTES

3480C/D-1 SERVICE NOTE

P.C. None

SUPersedes
NONE

hp MODEL 3480C/D DIGITAL VOLTMETER

Serial Numbers: All

REPLACEMENT PART NUMBERS FOR LED DISPLAYS

The LED displays (hp Part No. 1990-0330) used in the 3480C/D Digital Voltmeter come in seven different brightness categories. Replacement part numbers for each brightness category are listed below. The category is identified by a letter on the back of the display.

Brightness Category		Replacement Part Number
A	Dimmest ↑ ↓ Brightest	1990-0496
B		1990-0498
C		1990-0500
D		1990-0503
E		1990-0505
F		1990-0507
G		1990-0509

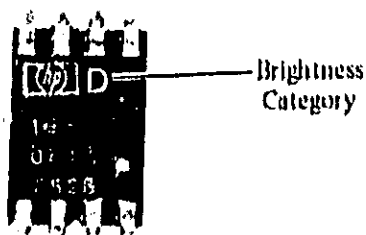

ELP/bjb/WO

10/74-09

Printed in U.S.A.

HEWLETT  PACKARD

For more information, call your local HP Sales Office or East (201) 265-6000 • Midwest (312) 677-0400 • South (404) 436-6181
West (213) 877-1282. Or, write: Hewlett-Packard, 1501 Page Mill Road, Palo Alto, California 94304. In Europe, 1217 Meyrin-Geneve.

3480C/D-2 SERVICE NOTE

P.C. 09-11054

SUPERSEDES
NONE

hp- MODEL 3480C/D DIGITAL VOLTMETER

Serial Numbers 3480C Prior to 1337A00174
3480D Prior to 1338A00302

TEMPERATURE SENSITIVE OPTICALLY ISOLATED BCD OPERATION

The replacement of several resistors is recommended if the A11 Optically Isolated BCD Board (hp- Part Number 03480-66525 new or 03480-69525 rebuilt) exhibits failures related to high temperature operation.

When the optical isolator (hp- Part Number 1990-0444) operates at temperatures above 25°C, its current transfer ratio tends to degrade. If these devices are at the low end of their specifications at 25°C, they may malfunction at higher temperatures. Changing the collector resistors of the optical detectors from 4.7 kΩ (hp- Part Number 0683-4725) to 20 kΩ (hp- Part Number 0683-2035) makes more current available to the load. This will improve the operation of the optical isolators over the upper end of the operating temperature range.

False BCD outputs may be caused by noise in the shift register coding line. Random noise is picked up by IC11 through the base lead #7. Since this lead is not used in the circuit, clipping the lead off from both the circuit board and the IC body will reduce the capacitive coupling between the base and the noise sources.

The resistors that may have to be changed are the 4.7 kΩ resistors connected between pins 6 and 8 of the optical isolators A11 IC10 and A11 IC12 through A11 IC19. These resistors are R9, R13, R15, R17, R19, R21, R23, R25 and R27 as shown on the following component locator.

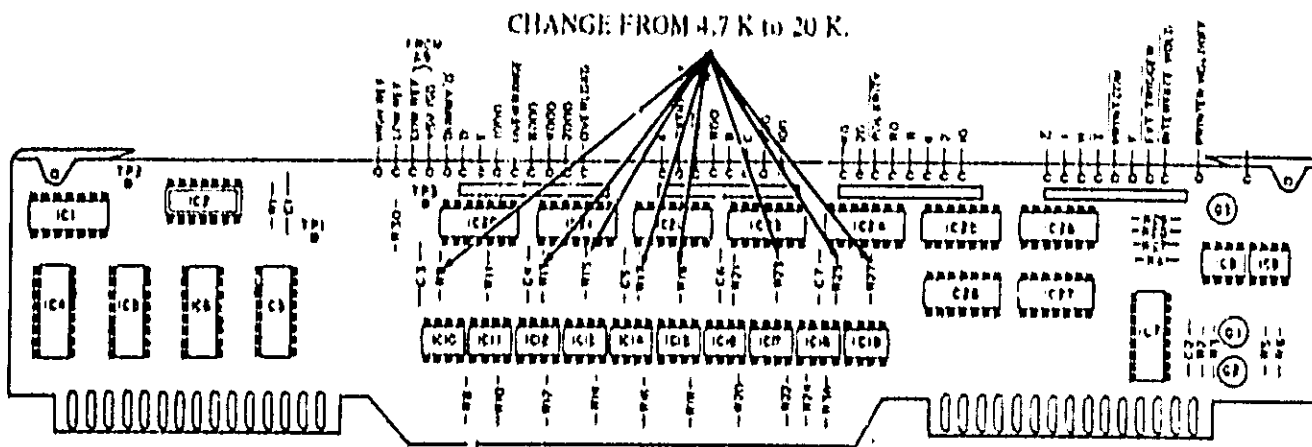

A11
03480-66525-2

Figure 1.

GWH/bjb/WO

4/75-Q9

Printed in U.S.A.

HEWLETT PACKARD

For more information, call your local HP Sales Office or East (201) 265-5000 • Midwest (312) 677-0400 • South (404) 436-6181
West (213) 877-1282. Or, write: Hewlett-Packard, 1501 Page Mill Road, Palo Alto, California 94304. In Europe, 1217 Meyrin-Geneva

Current schematics (Figure 7-11 of the Operating and Service Manual) of the A11 board show the 4.7 k Ω collector resistor between pins 6 and 8 of IC18 as R28. This designator is incorrect and should be changed to R25. The schematic also shows the 4.7 k Ω collector resistor between pins 6 and 8 of IC10 as R10. This designator is also incorrect and should be changed to R9. The resistor tied between pin 2 of IC11 and +5 volts is incorrectly shown on the schematic as R9. This designator should be changed to R10.

3480C/D-4 SERVICE NOTE

P.C. None

SUPPSEDES
NONE

MODEL 3480C/D DIGITAL VOLTMETER

Serial Numbers: All

RECOMMENDED REPLACEMENT FOR POWER SUPPLY CAPACITORS A6C2 THRU A6C7

The A6 Master Board Assembly may contain non-authorized* types of power supply filter capacitors. These capacitors may be readily identified as follows:

NON-AUTHORIZED* CAPACITORS

1. Black-Plastic Molded Case, Marked -CALLINS 510 microfarad
2. Gold-Plastic Sleeve, Marked -470 microfarad Hong Kong

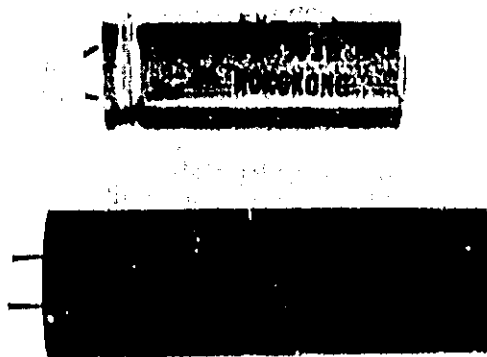

If a 3480C/D is found containing any of the non-authorized* capacitors, it is recommended they all be replaced to improve instrument reliability.

*Not authorized as a replacement or production part by LID.

DWG/bjb/WA

10/75-09

Printed in U.S.A.

HEWLETT  PACKARD

For more information, call your local HP Sales Office or East (201) 265-6000 • Midwest (312) 677-0400 • South (404) 436-6181
West (213) 877-1282. Or, write: Hewlett-Packard, 1501 Page Mill Road, Palo Alto, California 94304. In Europe, 1217 Meyrin-Geneva

RECOMMENDED REPLACEMENT

Part No. 0180-0476 Capacitor: Fxd 470 microfarad, +100/-10%



The correct polarity of the replacement capacitors must be determined by the polarity sign on the capacitor case.

NOTE

The following corrections should be made to the Operating and Service Manual:

1. Table 6-1, Replacement parts list:
Change the description of A6C2 thru A6C7 to indicate the value of 470 microfarad +100/-10%.
2. Figure 7-8.
 - a. Schematic diagram:
Change the value of A6C2 thru A6C7 to 470 microfarad.
 - b. A6 Component designator:
Change C1 (between C2 and C5) to indicate C4.

3480C/D-5 SERVICE NOTE

PC. None

SUPERSEDES
NONE

hp MODEL 3480C/D DIGITAL VOLTMETER

Serial Numbers All with Option 004 BCD Output Assemblies (hp Part Number 03480-66525 or 03480-69525, Revision A or Revision B).

IMPROVED OPERATION WITH hp-9800 SERIES CALCULATORS

This Service Note describes a modification to the A11 BCD Output board (hp Part Number 03480-66525 new or 03480-69525 rebuilt, prior to Revision C) that will improve operation with hp-9800 series Calculators. This modification adds a 15 microsecond delay to the leading edge of the 3480C/D Print Command signal which improves the timing relationship of the 3480C/D when interfaced to 9800 series Calculators using the 11203A BCD Interface.

MODIFICATION PROCEDURE

RECOMMENDED PARTS:

ITEM	DESCRIPTION	hp- PART NUMBER	QTY
1	14 pin IC socket	1200-0474	1
2	Eyelet	0361-0060	1
3	Tie Point	0360-1716	2
A11C28	IC (DTL - NAND Gate)	1820-0094	1
A11C100	Capacitor - Fsd .01 μ F	0160-0207	1

INSTRUCTIONS:

- 1) Turn off the instrument, remove the ac power cord, and remove the Model 3480C/D top cover to gain access to the circuit board.
- 2) Remove the two screws that hold the 50-pin BCD connector J13 in place. Disconnect (at the A9 board) the black and red wires that run from the A11 board to the A9 board. Gently lift the A11 BCD board up and disconnect the white lead from the pin near the rear of the instrument on the A0 Mother board. Completely remove the A11 board from the instrument.

NOTE

Refer to the schematic and component locator for the A11 BCD board for the following steps.

DWG/dlh/WA

10-75-09

Printed in U.S.A.

HEWLETT  PACKARD

For more information, call your local HP Sales Office or East (201) 265-6000 • Midwest (312) 677-0400 • South (404) 436-6181 West (213) 877-1282. Or, write: Hewlett-Packard, 1501 Page Mill Road, Palo Alto, California 94304. In Europe, 1217 Meyrin-Geneva

- 3) Remove and discard IC28.

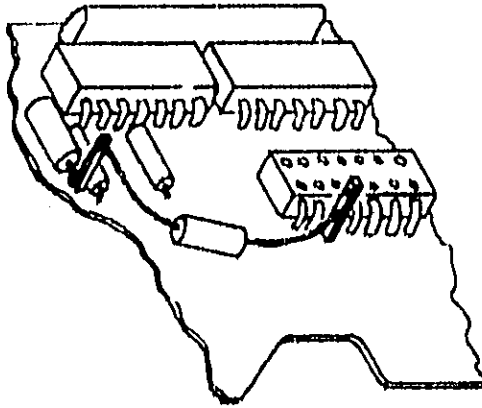

Figure 1.

NOTE

Refer to Figure 1 for the following steps.

- 4) Add a tie point beside IC28 pin 3.
- Carefully drill a # 51 (.067 dia) hole beside IC28 pin 3.
 - Install eyelet (0361-0060) in drilled hole.
 - Insert IC socket (1209-0474) for IC28.
 - Insert tie point (0360-1716) in eyelet.
 - Carefully solder the IC socket, insuring good solder connection from pin 3 of IC socket to the eyelet and tie point.
- 5) Install a tie point at C7.
- Unsolder and carefully lift end of C7.
 - Insert tie point -lip- (0360-1716) in its place.
 - Wrap lead of C7 around tie point.
- 6) Install .01 μ f Capacitor -lip- (0160-0207) between these two added tie points.
- Complete soldering of tie points and capacitors.
- 7) Install the new IC28 -lip- (1820-0094).
- 8) Update your Operating and Service Manual to reflect the changes made.

PERFORMANCE CHECK

The 3480C/D will not need to be recalibrated after this modification, although a performance check of the BCD output should be made.