



Agilent 5530 Dynamic Calibrator

Data Sheet



Power Requirements

Laser Head:

100 – 240 Vac, 50/60 Hz
50W (during warmup), 33W (after warmup)

Calibrator Electronics (all +5V via USB):

E1735A 280 mA max (plus 55290B if used)
E1736A 120 mA (plus sensors)
E1737A 6 mA maximum, 0.3 mA typical
E1738A 6 mA maximum, 0.6 mA typical
55290B 250 mA maximum

System Requirements

Environmental

Operating Temperature: 0 – 40°C (32 – 104°F)
Optics temperature must be stabilized to $\pm 2^\circ\text{C}$ to achieve accuracy specifications.

PC Requirements

Compatible with any portable computer with Windows® XP, Windows Vista (32-bit), Windows 7 (32-/64-bit) or Windows 8 (32-/64-bit) and two USB 2.0 ports and a CD drive

"Windows" is a registered trademark of Microsoft, Inc.

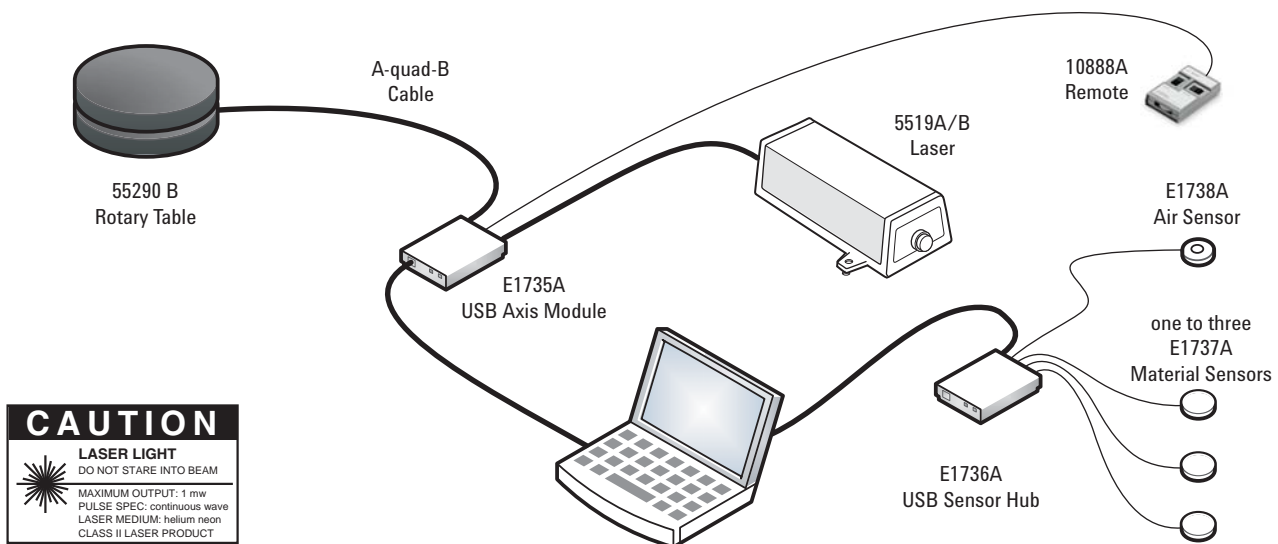

Agilent Technologies

Laser Characteristics

Type: Helium-Neon with automatically tuned Zeeman-split two-frequency output

Output Power: $\geq 180 \mu\text{W}$
($< 1 \text{ mW}$ per Class II Laser Product)

Safety Classification:

Class II Laser Product conforming to U.S. National CDRH Regulations 21CFR 1040.10 and 1040.11.

Warm-up Time: Less than 10 minutes
(4 minutes typical)

Vacuum Wavelength: 632.991354 nm

Wavelength Accuracy: $\pm 0.1 \text{ ppm}$
($\pm 0.02 \text{ ppm}$ of measured wavelength with factory calibration, Option UK6)

Wavelength Stability (typical):
short term (1 hour): $\pm 0.002 \text{ ppm}$
long term (lifetime): $\pm 0.02 \text{ ppm}$

Beam Diameter: 6 mm (0.24 in)

Beam Centerline Spacing:
11.0 mm (0.44 in) (input to output aperture)

Linear Distance, Diagonal, and Velocity Measurement Specifications

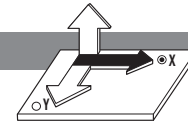

Measurement Range

Up to 40 m (130 ft) with Linear Optics;
Up to 80 m (260 ft) with Long Range Option

Linear Distance and Diagonal Measurement Accuracy

Temperature Range, °C [°F]	E1738A	
	Air Sensor	In Vacuum †
0 – 40° [32° – 104°]	$\pm 0.4 \text{ ppm}$	$\pm 0.1 (\pm 0.02) \text{ ppm}$

† Vacuum accuracy is $\pm 0.02 \text{ ppm}$ if the laser head is calibrated to MIL-STD 45662A.

Velocity Measurement Accuracy

$$\left[\frac{2 \mu\text{m/s}}{\text{Velocity}} + 0.01 \right] \% \text{ of displayed value}$$

Linear Distance and Diagonal Measurement Performance

OPTICS	RESOLUTION	MAXIMUM AXIS VELOCITY	
		5519A	5519B
Linear Optics (10766A)	1 nm (0.04 μin)	$\pm 0.7 \text{ m/s}$ ($\pm 28 \text{ in/s}$)	$\pm 1 \text{ m/s}$ ($\pm 40 \text{ in/s}$)
Plane Mirror Optics (10706A/B) *	0.5 nm (0.02 μin)	$\pm 0.35 \text{ m/s}$ ($\pm 14 \text{ in/s}$)	$\pm 0.5 \text{ m/s}$ ($\pm 20 \text{ in/s}$)
High Resolution Plane Mirror Optics (10716A) *†	0.25 nm (0.01 μin)	$\pm 0.18 \text{ m/s}$ ($\pm 7 \text{ in/s}$)	$\pm 0.25 \text{ m/s}$ ($\pm 10 \text{ in/s}$)

* Requires the 10724A Plane Mirror Reflector. Since alignment of these optics is much more sensitive than for linear optics, linear optics are recommended for general use.

† Aperture distance of 10716A is 12.7 mm, whereas 5519A is 11 mm.

Angular Measurement Specifications

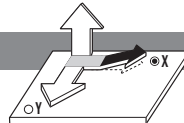

Angle Measurement Accuracy

$\pm 0.2\%$ of displayed value
 $\pm 0.05 \text{ arc-seconds}$ per meter of distance traveled by the linearly moving optic.

Maximum Distance Between Laser Head and Reflector

Up to 15 m (50 ft)

Angle Measurement Resolution

0.005 arc-seconds

Measurement Range

$\pm 10^\circ$ (rotated about base of optic)
 $\pm 20^\circ$ (rotated about center of optic)

Measurement Type

Pitch and yaw

Angular Position Measurement Specifications

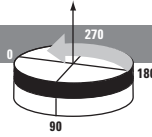

55290A Rotary Axis Kit

Measurement Type

Rotary and indexing tables or spindles

Indexing Mode (zero-reference measurement)

Accuracy: 0.5 sec band +0.2% of displayed reading

Index Step Size: 1°

Range: multiple rotations or partial arcs

Laser Measurement Mode

Accuracy: 0.2% of displayed reading. Accuracy can be improved to 0.5 sec by calibrating laser optics with the indexing table (55290A).

Range: ±10°

Setup Requirements

Travel (using +2 mm, -1 mm machine axis, or manual from zero reference)

Indexing Mode (Interferometer in fixture)

Maximum Lift: 15 mm (2 mm required for fixture)

55290B Rotary Axis Kit

Measurement Type

Rotary and indexing tables or spindles

Combined Mode (zero-reference measurement)

Accuracy: ±1.0 arc-second

Resolution: 0.036 arc-seconds

Range: multiple rotations or partial arcs

Laser Measurement Mode

Accuracy: 0.2% of displayed reading. Accuracy can be improved to 1 sec by calibrating laser optics with the indexing table (55290B).

Range: ±10°

Setup Requirements

Travel – none required

Connects to 5530 system via E1735A Axis Module

Flatness and Way Straightness Measurement Specifications ¹

1. Values do not include effects of surface cleanliness or operator positioning repeatability.



Flatness Measurement Accuracy

±0.2% of displayed value

±0.05 arc-seconds per meter of distance traveled by the moving optic

Flatness Measurement Resolution (per step)

Footspacing Dimension	Resolution
50.8 mm (2 in)	0.03 micron (1.0 μin)
101.6 mm (4 in)	0.05 micron (2.0 μin)
152.4 mm (6 in)	0.08 micron (3.0 μin)

Way Straightness Accuracy

±0.2% of displayed value

±0.05 arc seconds per meter of distance traveled by the moving optics

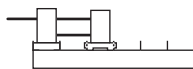

Flatness and Way Straightness Maximum Range

15m (50 ft)

Reference Plane Accuracy

The uncertainty of a surface plate flatness measurement is bounded by two parallel planes separated by the values below:

Metric Units Mode: $0.03 (M)^2 \mu\text{m}$

English Units Mode: $0.12 (F)^2 \mu\text{in}$

where:

M = length of the surface diagonal in meters

F = length of the surface diagonal in feet

Lateral Offset and Flatness Range

The combination of lateral offset and maximum flatness deviation must not displace the reflector more than ±1.0 mm from the beam path in any direction.

Straightness and Parallelism Measurement Specifications

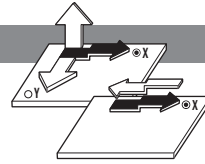

Straightness Measurement Accuracy ¹

Overall Accuracy = Optical Reference Accuracy
+ Measurement Accuracy

1. This is analogous to the traditional straightedge and indicator method of measuring straightness, where Optical Reference Accuracy corresponds to the straightedge accuracy, and Measurement Accuracy corresponds to the indicator accuracy.

Optical Reference Accuracy

Optical reference inaccuracy can be eliminated by using straightedge (mirror) reversal techniques.

Short Range Optics:

Metric units mode: $\pm 0.15 (M)^2 \mu\text{m}$

English units mode: $\pm 0.5 (F)^2 \mu\text{in}$

Long Range Optics:

Metric units mode: $\pm 0.015 (M)^2 \mu\text{m}$

English units mode: $\pm 0.05 (F)^2 \mu\text{in}$

where:

M = distance of travel of the moving optic in meters

F = distance of travel of the moving optic in feet

Straightness Measurement Range (Orthogonal to Axial Travel)

$\pm 1.5 \text{ mm}$ (0.060 in)

Axial Separation (Travel)

(distance between the interferometer and the reflector, typical, with proper alignment, 15 – 25 °C):

Short Range Optics: 0.1 – 3m (4 – 120 in)

Long Range Optics: 1 – 30m (3 – 100 ft)

Measurement Accuracy ²

Short Range Optics:

Temperature Range	Displayed Value	
	0 – 10 μm (0 – 400 μin)	10 – 1,500 μm (400 – 60,000 μin)
0 – 40 °C	$\pm 3.5\%$	$\pm 1\% \pm 0.25 \mu\text{m}$ (10 μin)

Long Range Optics:

Temperature Range	Displayed Value	
	0 – 100 μm (0 – 4,000 μin)	100 – 1,500 μm (4,000 – 60,000 μin)
0 – 40 °C	$\pm 5\%$	$\pm 2.5\% \pm 2.5 \mu\text{m}$ (100 μin)

Straightness ² Measurement Resolution

<i>Short Range</i>	0.01 μm (0.4 μin)
--------------------	---

<i>Long Range</i>	0.1 μm (4 μin)
-------------------	--

2. These specs are not applicable to Timebase Straightness Measurements.

Squareness Measurement Accuracy

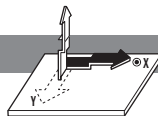

Short Range Optics:

Metric Units Mode:

$\pm(1.0 + 0.1 M) \text{ arc-seconds } \pm 0.01 \theta$

English Unit Mode:

$\pm(1.0 + 0.03 F) \text{ arc-seconds } \pm 0.01 \theta$

Long Range Optics:

Metric Units Mode:

$\pm(1.0 + 0.01 M) \text{ arc-seconds } \pm 0.025 \theta$

English Units Mode:

$\pm(1.0 + 0.003 F) \text{ arc-seconds } \pm 0.025 \theta$

where:

θ = calculated out-of-square angle in arc-seconds

M = distance of travel of the moving optic in meters

F = distance of travel of the moving optic in feet

Environmental Compensation¹ and A-quad-B Input

1. Compensation values may be manually entered by user via keyboard.

E1738A Air Sensor²

2. Refer to the E1738A Air Sensor Data Sheet, 5989-8456 for more specifications.

Wavelength of Light (WOL) in Air Compensation

The E1738A Air Sensor provides for the automatic display of pressure, temperature, relative humidity, and computed WOL.

Operating Range

Temperature: 0 – 40°C (32 – 104°F)

Relative Humidity: 10% – 90%

Absolute Pressure: 70 – 110 kPa (10 – 16 psia)

Heat Dissipation: 2 mW typical

Time Constant: 5 min typical (temperature)

Accuracy⁴

Temperature: ± 0.1°C (± 0.2°F)

Relative Humidity: ± 5%

Absolute Pressure: ± 50 Pa (± 0.008 psi)

4. 12 month calibration interval

E1737A Material Temperature Sensor³

3. Refer to the E1737A Material Sensor Data Sheet, 5989-8455 for more specifications.

Material Temperature Compensation

The E1737A Material Temperature Sensor provides for the automatic display of the temperature of the device under test. One to three sensors may be used.

Operating Range

Temperature: 0 – 40°C (32 – 104°F)

Material Expansion Coefficient:
range: –100.0 to +100.0 ppm per °C or °F,
manually entered.

Heat Dissipation: 1 mW typical

Time Constant: 60s typical

Accuracy⁴

Temperature: ± 0.1°C (± 0.2°F)

4. 12 month calibration interval

Shared Sensor Characteristics

Maximum Compensation Update Rate

per 15s (combined WOL and material temperature compensation)

Cable Lengths:

E1739A—5m (16 ft)

E1739B—10m (33 ft)

E1739C—15m (49 ft)

E1739D—25m (82 ft)

A-quad-B Input

Differential Input Threshold

±0.5V minimum, ±7.0V maximum

Differential Input Impedance

100 Ω

Input Rate

>2 ns edge-to-edge, or <10 MHz information rate
example: at maximum speed, A and B both must be <2.5 MHz.

System Component Dimensions and Weights

Agilent 5519A/B Laser Head

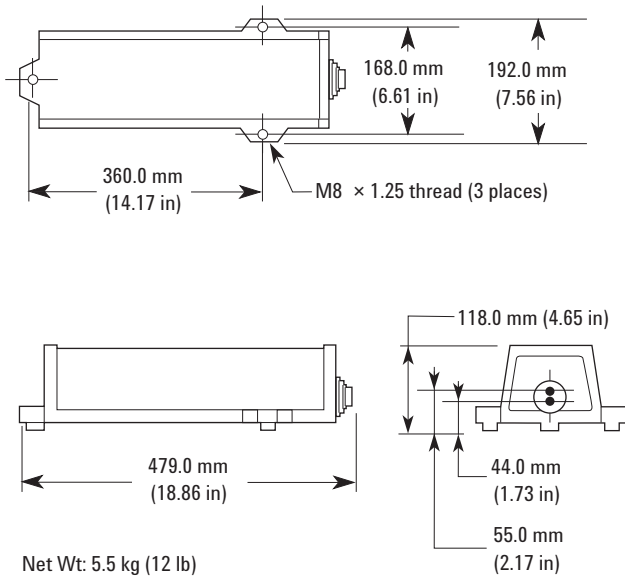

Agilent 10753B Laser Tripod

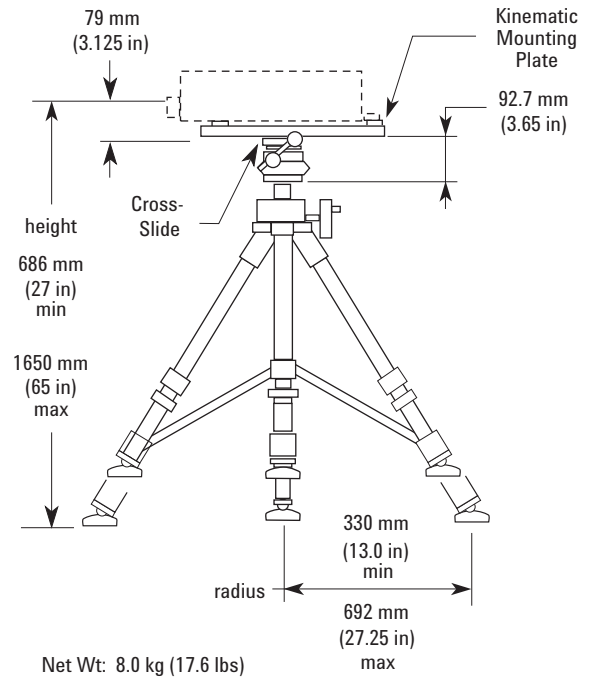

E1735A USB Axis Module

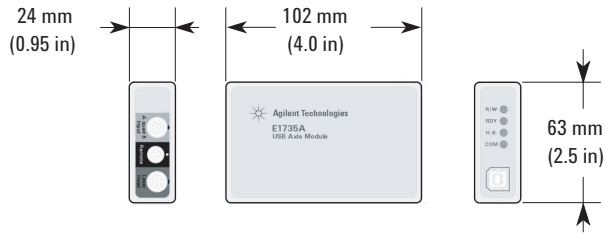

E1736A USB Sensor Hub



E1737A Material Sensor

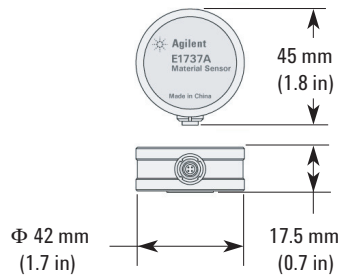

E1738A Air Sensor

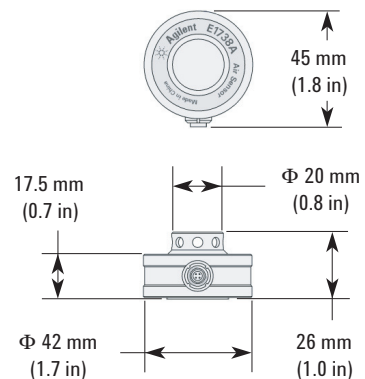

Linear Optics

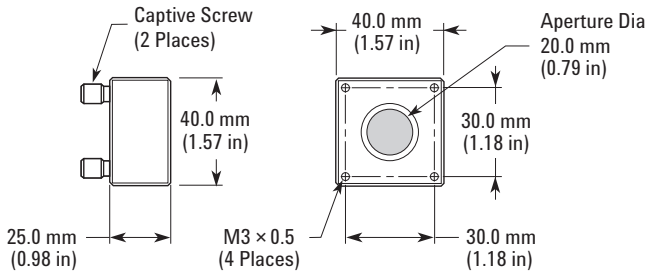

Agilent 10767A Linear Retroreflector

Net Wt: 224g (0.5 lb)

Angular Optics

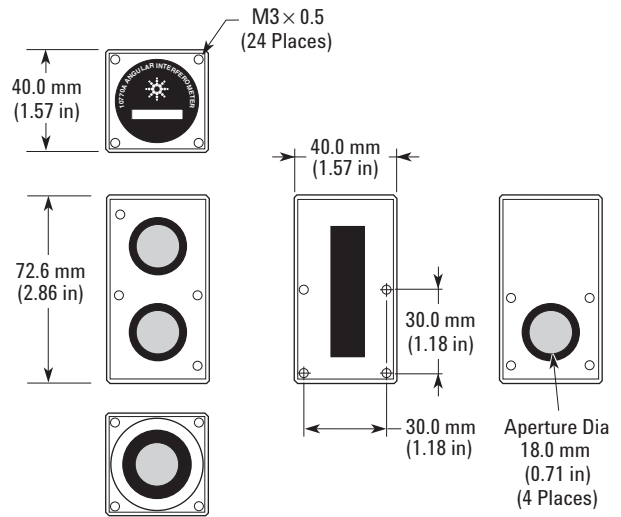

Agilent 10770A Angular Interferometer

Net Wt: 553g (1.3 lb)

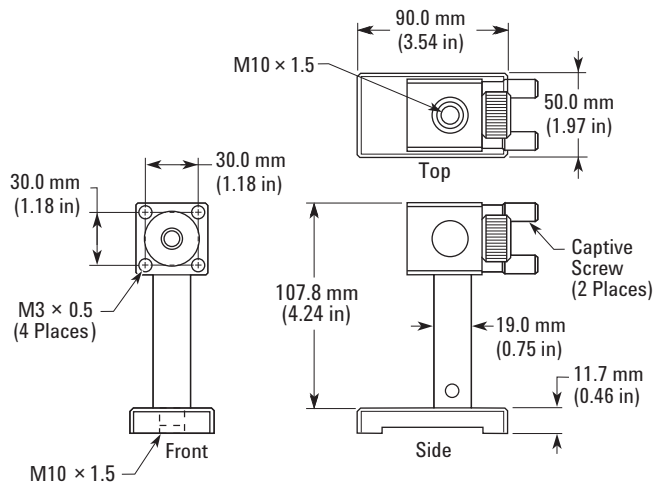

Agilent 10785A Height Adjuster/Post, 10784A Base

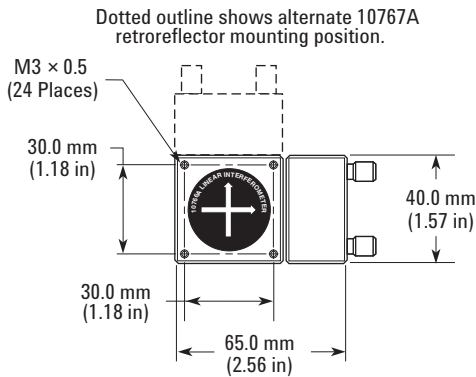

Agilent 10766A/10767A Interferometer Combination

Net Wt: 5.36g (1.2 lb)

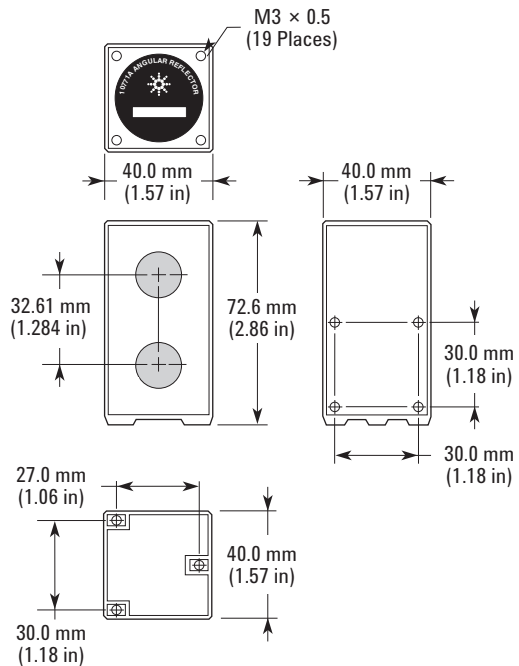

Agilent 10771A Angular Reflector

Net Wt: 650g (1.5 lb)

Flatness Accessories

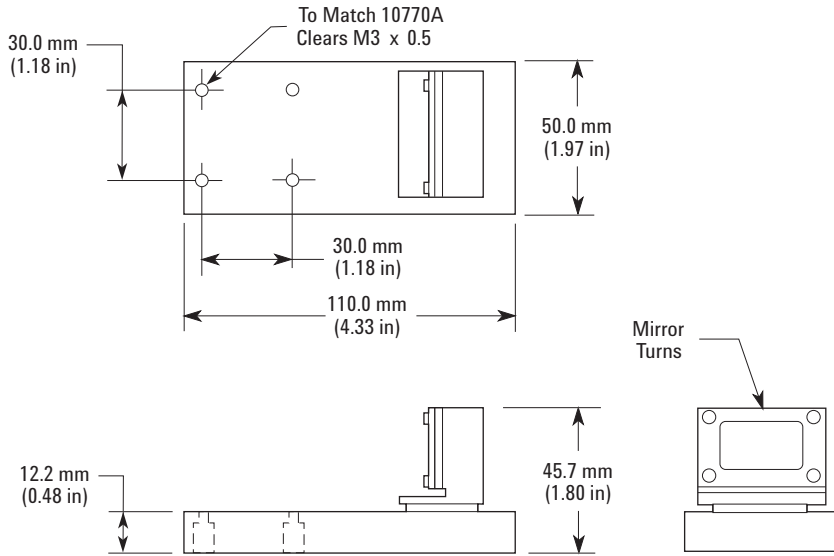

Agilent 10773A Flatness Mirror

Net Wt: 661g (1.5 lb)

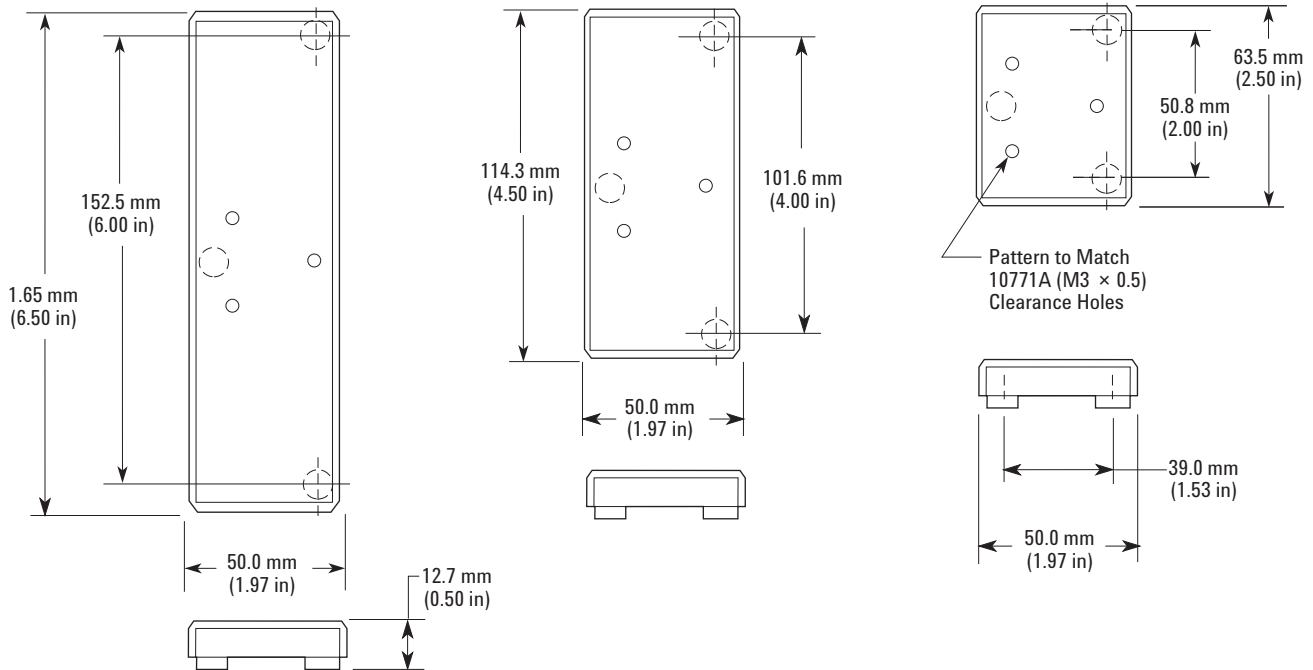

Agilent 10759A Foot Spacing Kit

Net Wt: 661g (1.5 lb)

Straightness / Squareness Optics

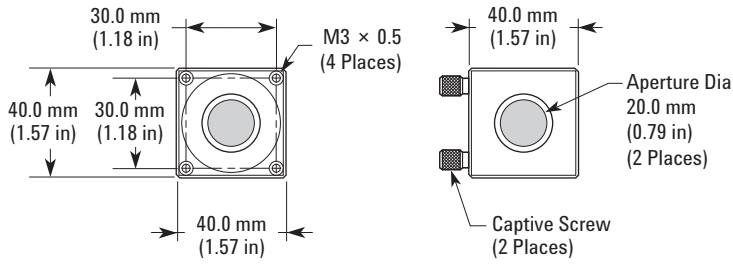

Agilent 10772A Tuning Mirror

Net Wt: 510g (1.2 lb) w/Mount

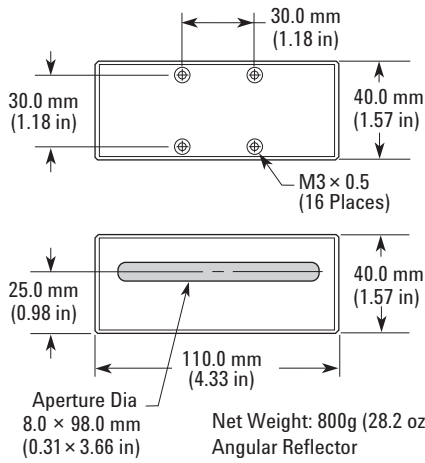

**Net Weight: 800g (28.2 oz)
Angular Reflector**

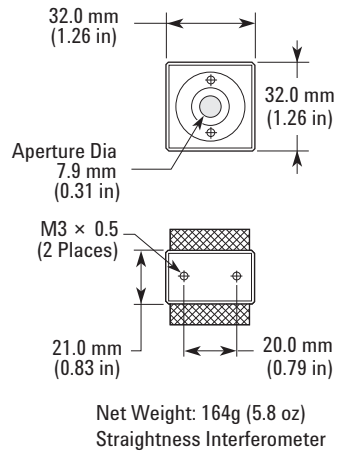

**Net Weight: 164g (5.8 oz)
Straightness Interferometer**

Agilent 10774A Short Range Straightness Optics/10775A Long Range Straightness Optics

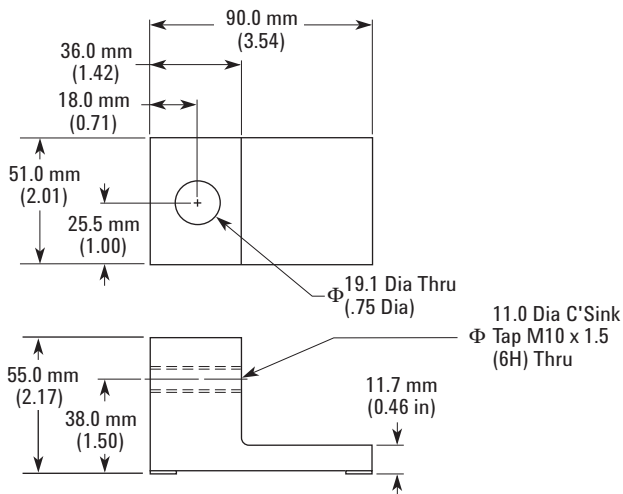

Agilent 10776A Straightness Mount

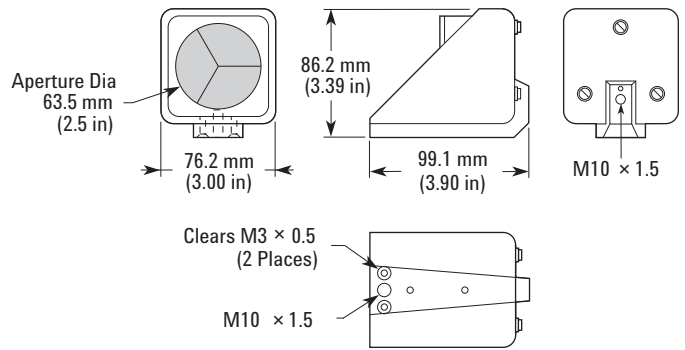

Agilent 10776-67001 Straightness Retroreflector

Net Wt: 374g (0.82 lb)

Straightness / Squareness Optics

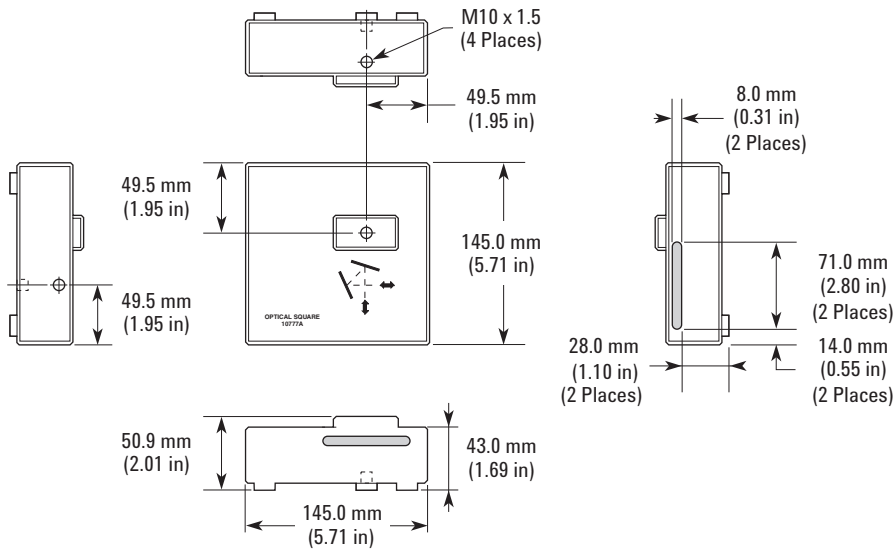

Agilent 10777A Optical Square

Net Wt: 4.0 kg (8.9 lb) w/Mount

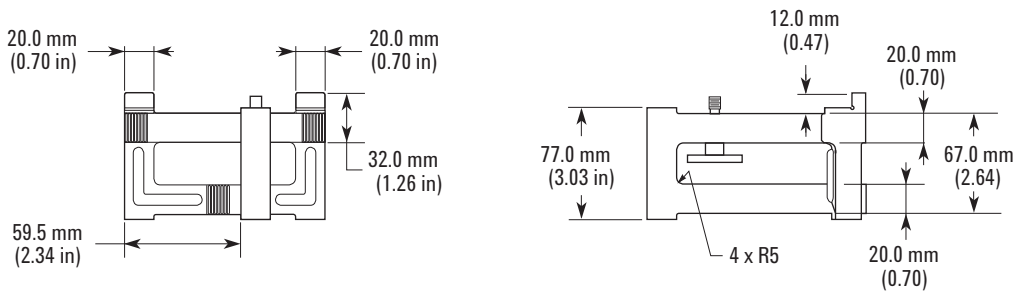
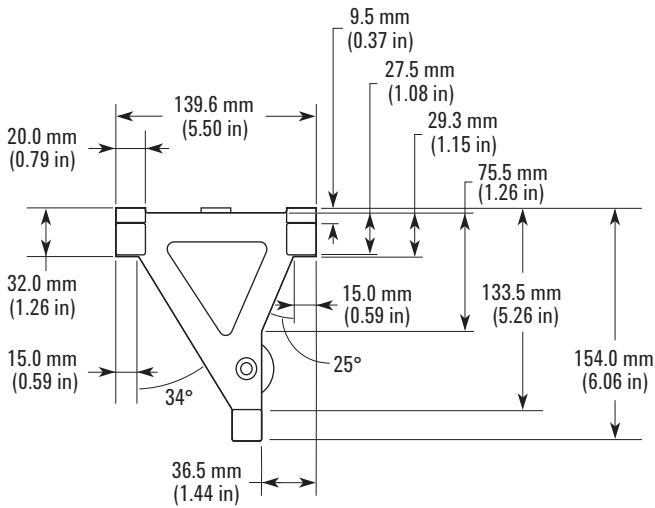

Agilent 10777-20007 Optical Square Base

Straightness / Squareness Optics

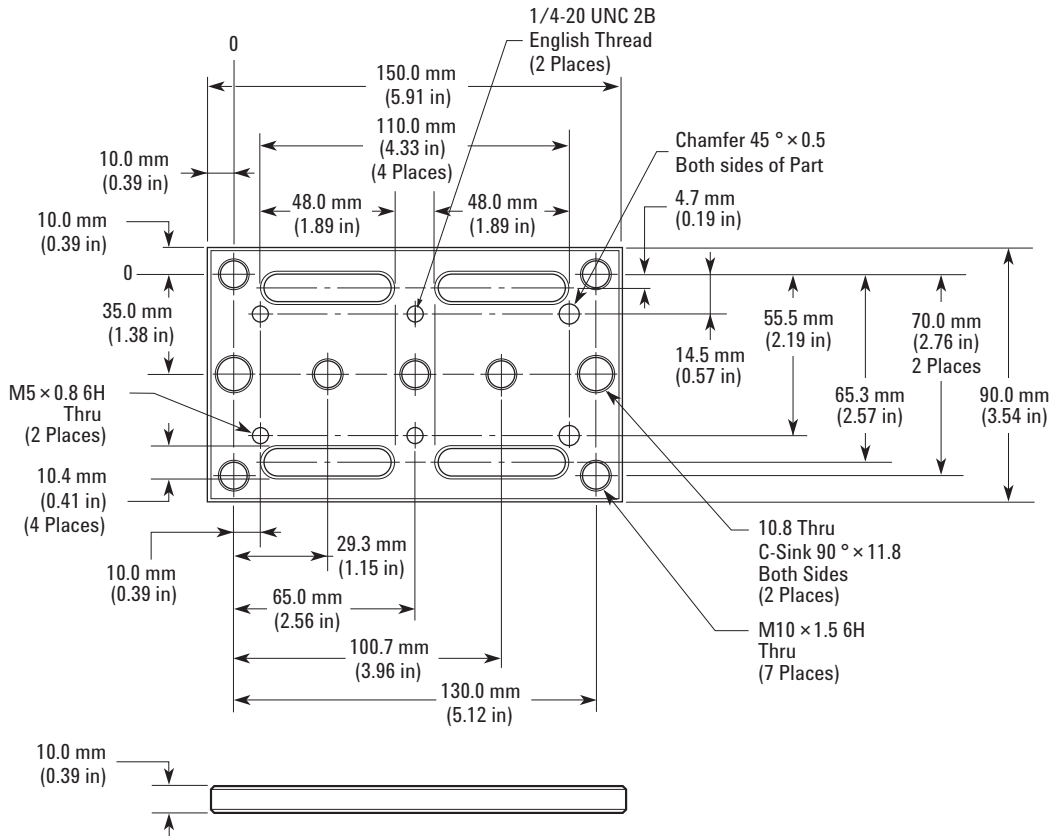

Agilent 10768-20214 Base - Large

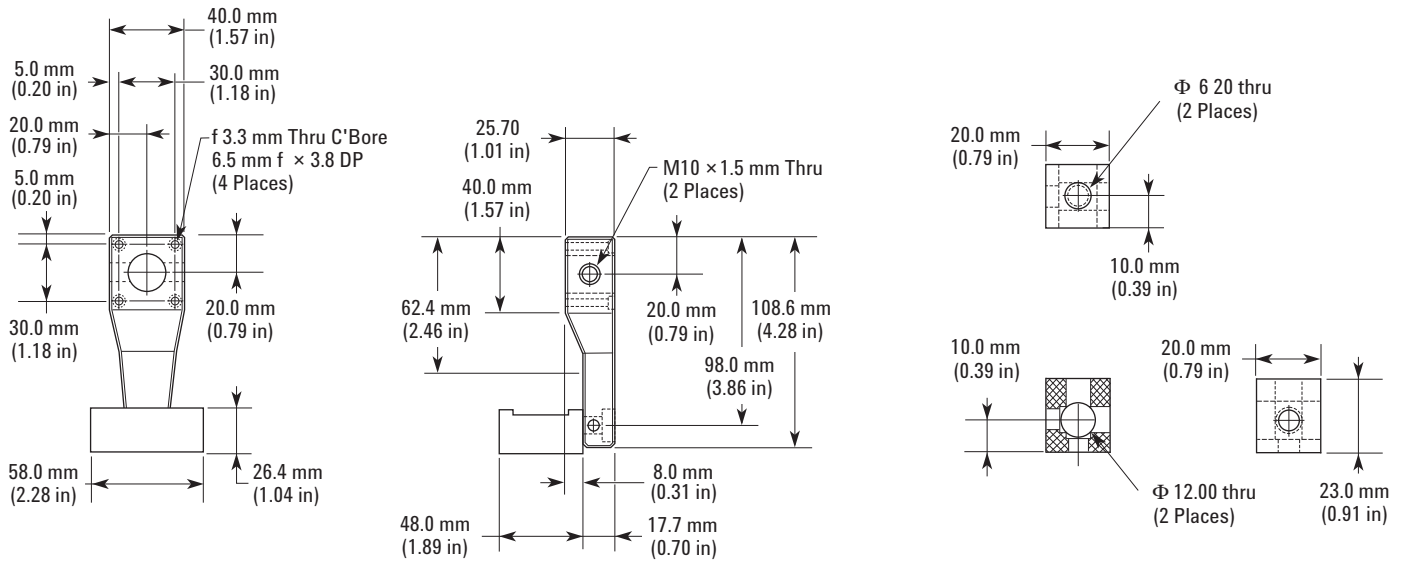

from Agilent 10768A/10769A Measurement Kit

Agilent 10769B Turning Mirror (Base Block Only)

Agilent 55290A Angular Position Measurement Kit

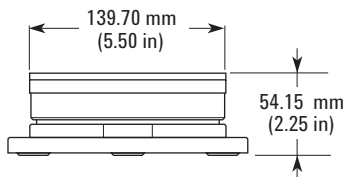
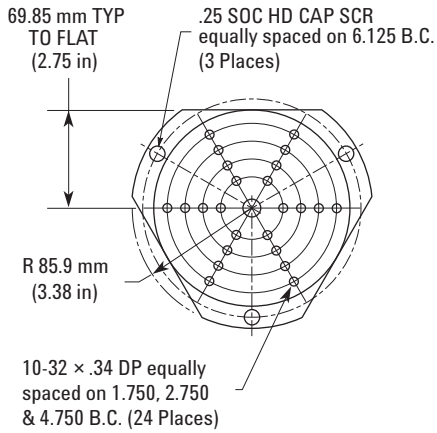

Rotary Indexing Table

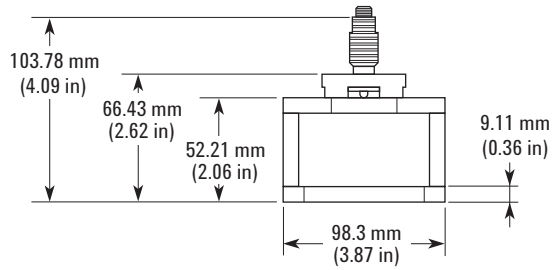
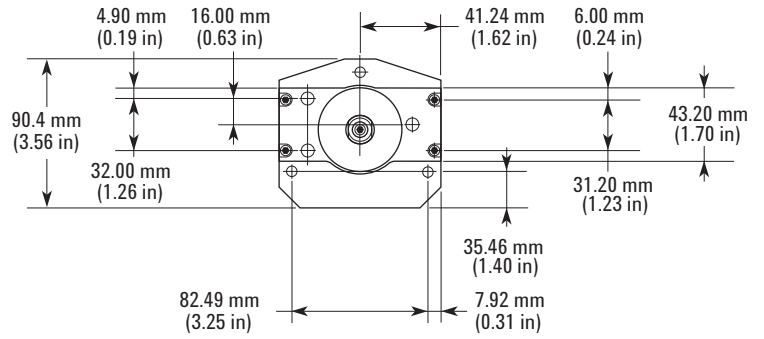

Fixture, Angle Position Measurement

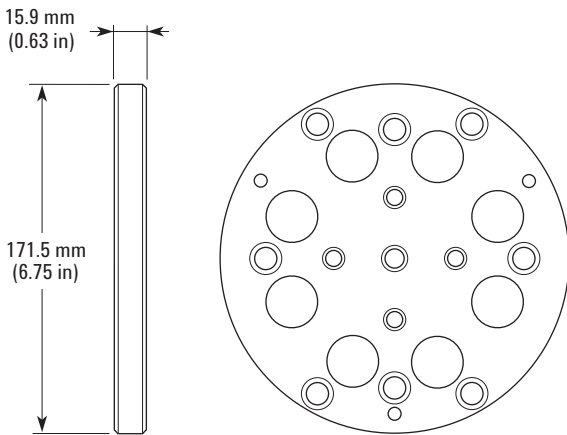

Adapter Plate

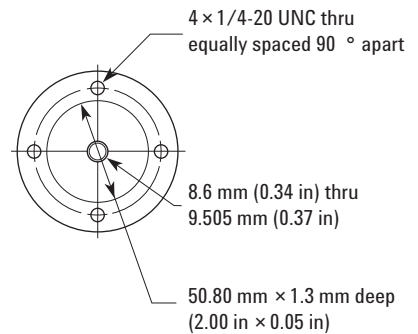
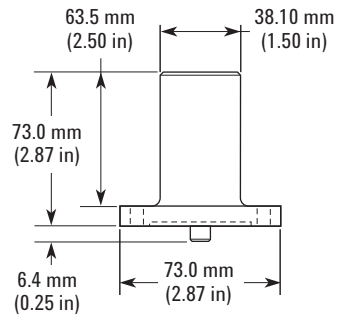

Flanged Shaft

Agilent 55290B Angular Position Measurement Kit

Adapter Plate

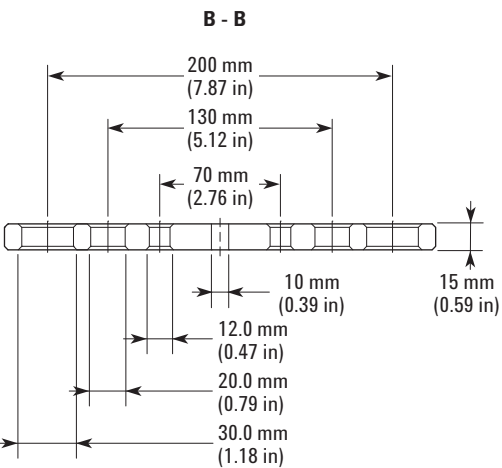
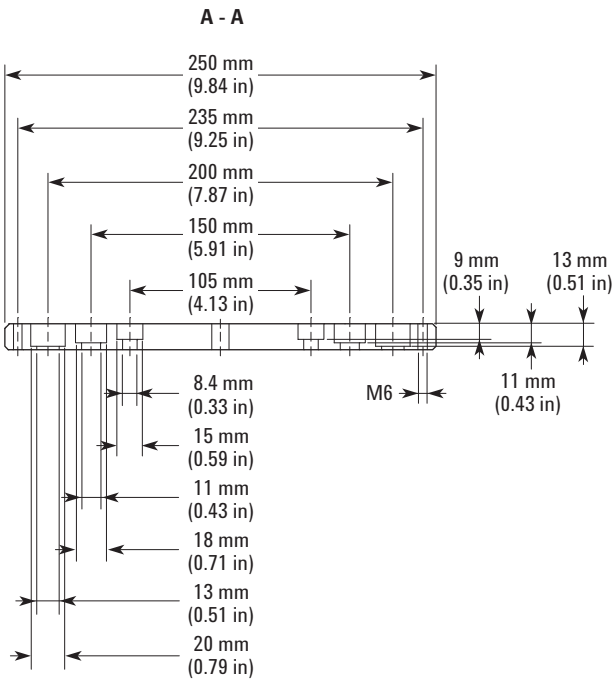
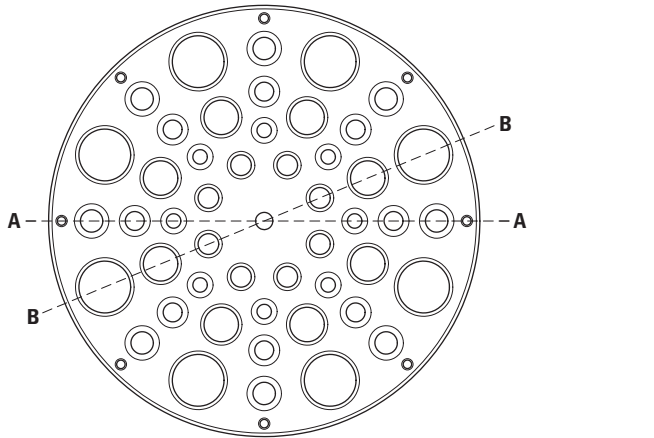

Flanged Shaft

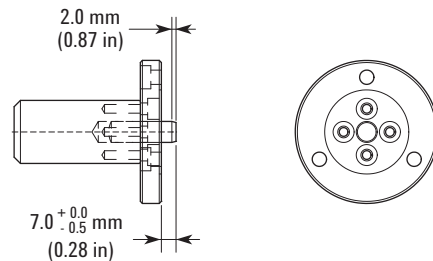
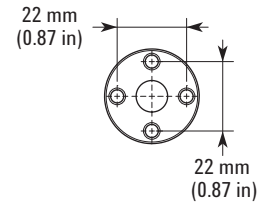
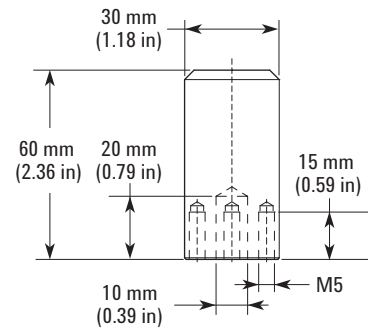
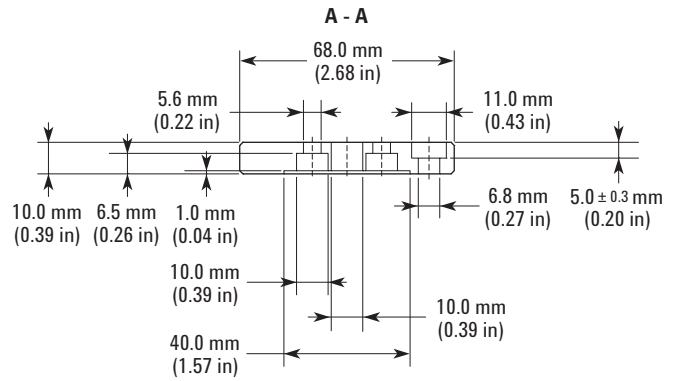
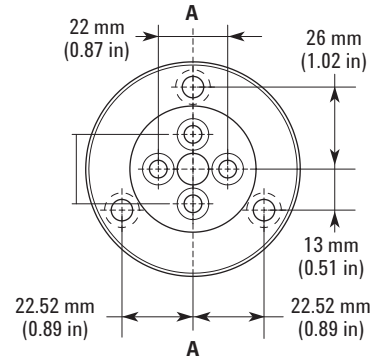

Agilent Technologies' Test and Measurement Support, Services, and Assistance

Agilent Technologies aims to maximize the value you receive, while minimizing your risk and problems. We strive to ensure that you get the test and measurement capabilities you paid for and obtain the support you need. Our extensive support resources and services can help you choose the right Agilent products for your applications and apply them successfully. Every instrument and system we sell has a global warranty. Support is available for at least five years beyond the production life of the product. Two concepts underlie Agilent's overall support policy: "Our Promise" and "Your Advantage."

Our Promise

Our Promise means your Agilent test and measurement equipment will meet its advertised performance and functionality. When you are choosing new equipment, we will help you with product information, including realistic performance specifications and practical recommendations from experienced test engineers. When you receive your new Agilent equipment, we can help verify that it works properly and help with initial product operation.

Your Advantage

Your Advantage means that Agilent offers a wide range of additional expert test and measurement services, which you can purchase according to your unique technical and business needs. Solve problems efficiently and gain a competitive edge by contracting with us for calibration, extra-cost upgrades, out-of-warranty repairs, and onsite education and training, as well as design, system integration, project management, and other professional engineering services. Experienced Agilent engineers and technicians worldwide can help you maximize your productivity, optimize the return on investment of your Agilent instruments and systems, and obtain dependable measurement accuracy for the life of those products.



Agilent Email Updates

www.agilent.com/find/emailupdates

Get the latest information on the products and applications you select.

Agilent T&M Software and Connectivity

Agilent's Test and Measurement software and connectivity products, solutions and developer network allows you to take time out of connecting your instruments to your computer with tools based on PC standards, so you can focus on your tasks, not on your connections. Visit www.agilent.com/find/connectivity for more information.

For more information on Agilent Technologies' products, applications or services, please contact your local Agilent office. The complete list is available at: www.agilent.com/find/contactus

More information about Agilent Technologies' laser interferometric dynamic calibrators is available at: www.agilent.com/find/machinetoolcalibration

Phone or Fax

United States:

(tel) 800 829 4444
(fax) 800 829 4433

Canada:

(tel) 877 894 4414
(fax) 905 282 6495

China:

(tel) 800 810 0189
(fax) 800 820 2816

Europe:

(tel) 31 20 547 2111

Japan:

(tel) (81) 426 56 7832
(fax) (81) 426 56 7840

Korea:

(tel) (080) 769 0800
(fax) (080)769 0900

Latin America:

(tel) (305) 269 7500

Taiwan:

(tel) 0800 047 866
(fax) 0800 286 331

Other Asia Pacific Countries:

(tel) (65) 6375 8100
(fax) (65) 6755 0042
Email: tm_ap@agilent.com

Product specifications and descriptions in this document subject to change without notice.

© Agilent Technologies, Inc. 2014
Printed in USA, January 22, 2014
5989-9712EN



Agilent Technologies