ADVANTEST[®]

ADVANTEST CORPORATION

Q7606A/B

Optical Chirpform Test Set

Operation Manual

MANUAL NUMBER FOE-8335028A01

Safety Summary

To ensure thorough understanding of all functions and to ensure efficient use of this instrument, please read the manual carefully before using. Note that Advantest bears absolutely no responsibility for the result of operations caused due to incorrect or inappropriate use of this instrument.

If the equipment is used in a manner not specified by Advantest, the protection provided by the equipment may be impaired.

- **Warning Labels**

Warning labels are applied to Advantest products in locations where specific dangers exist. Pay careful attention to these labels during handling. Do not remove or tear these labels. If you have any questions regarding warning labels, please ask your nearest Advantest dealer. Our address and phone number are listed at the end of this manual.

Symbols of those warning labels are shown below together with their meaning.

DANGER: Indicates an imminently hazardous situation which will result in death or serious personal injury.

WARNING: Indicates a potentially hazardous situation which will result in death or serious personal injury.

CAUTION: Indicates a potentially hazardous situation which will result in personal injury or a damage to property including the product.

- **Basic Precautions**

Please observe the following precautions to prevent fire, burn, electric shock, and personal injury.

- Use a power cable rated for the voltage in question. Be sure however to use a power cable conforming to safety standards of your nation when using a product overseas.
- When inserting the plug into the electrical outlet, first turn the power switch OFF and then insert the plug as far as it will go.
- When removing the plug from the electrical outlet, first turn the power switch OFF and then pull it out by gripping the plug. Do not pull on the power cable itself. Make sure your hands are dry at this time.
- Before turning on the power, be sure to check that the supply voltage matches the voltage requirements of the instrument.
- Be sure to plug the power cable into an electrical outlet which has a safety ground terminal. Grounding will be defeated if you use an extension cord which does not include a safety ground terminal.
- Be sure to use fuses rated for the voltage in question.
- Do not use this instrument with the case open.

Safety Summary

- Do not place objects on top of this product. Also, do not place flower pots or other containers containing liquid such as chemicals near this product.
- When the product has ventilation outlets, do not stick or drop metal or easily flammable objects into the ventilation outlets.
- When using the product on a cart, fix it with belts to avoid its drop.
- When connecting the product to peripheral equipment, turn the power off.

- **Caution Symbols Used Within this Manual**

Symbols indicating items requiring caution which are used in this manual are shown below together with their meaning.

DANGER: Indicates an item where there is a danger of serious personal injury (death or serious injury).

WARNING: Indicates an item relating to personal safety or health.

CAUTION: Indicates an item relating to possible damage to the product or instrument or relating to a restriction on operation.

- **Safety Marks on the Product**

The following safety marks can be found on Advantest products.

 : ATTENTION - Refer to manual.

 : Protective ground (earth) terminal.

 : DANGER - High voltage.

 : CAUTION - Risk of electric shock.

- **Replacing Parts with Limited Life**

The following parts used in the instrument are main parts with limited life.

Replace the parts listed below after their expected lifespan has expired.

Note that the estimated lifespan for the parts listed below may be shortened by factors such as the environment where the instrument is stored or used, and how often the instrument is used.

There is a possibility that each product uses different parts with limited life. For more information, refer to Chapter 1.

Main Parts with Limited Life

| Part name | Life |
|------------------------|-----------|
| Unit power supply | 5 years |
| Fan motor | 5 years |
| Electrolytic capacitor | 5 years |
| LCD panel | 6 years |
| LCD backlight | 2.5 years |
| Floppy disk drive | 5 years |

- **Precautions when Disposing of this Instrument**

When disposing of harmful substances, be sure dispose of them properly with abiding by the state-provided law.

Harmful substances: (1) PCB (polycarbon biphenyl)
 (2) Mercury
 (3) Ni-Cd (nickel cadmium)
 (4) Other

Items possessing cyan, organic phosphorous and hexadic chromium and items which may leak cadmium or arsenic (excluding lead in solder).

Example: fluorescent tubes, batteries

Environmental Conditions

This instrument should be only be used in an area which satisfies the following conditions:

- An area free from corrosive gas
- An area away from direct sunlight
- A dust-free area
- An area free from vibrations

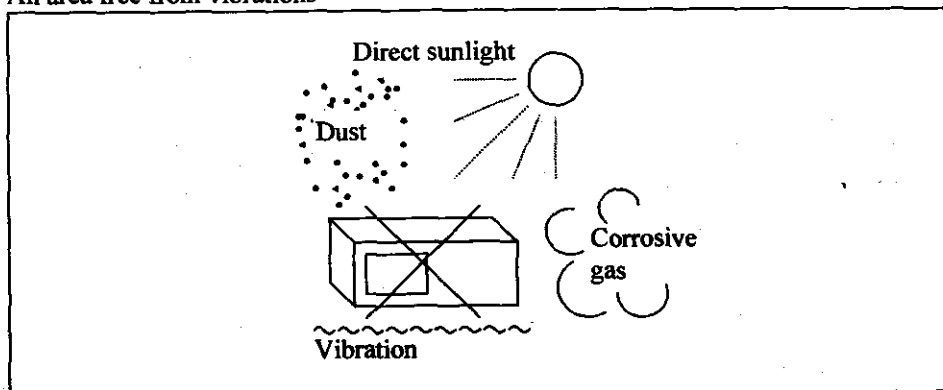

Figure-1 Environmental Conditions

- Instrument Placement

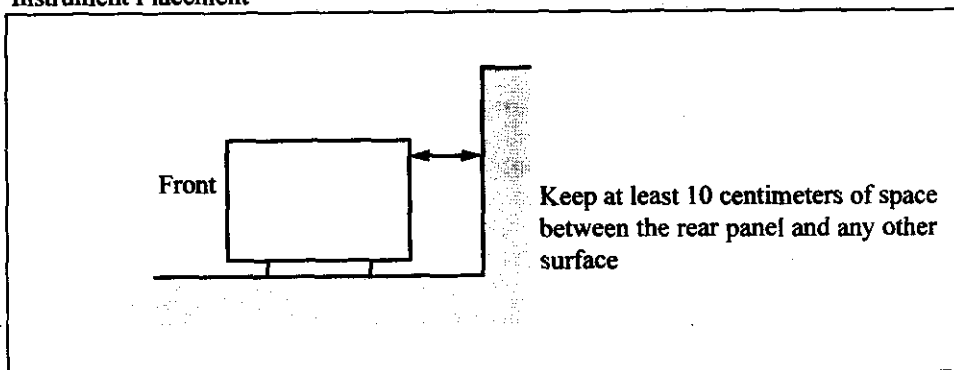
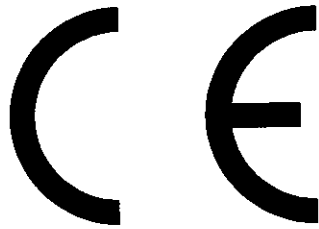

Figure-2 Instrument Placement

This instrument can be used safely under the following conditions:

- Altitude of up to 2000 m
- Installation Categories II
- Pollution Degree 2

Certificate of Conformity



This is to certify, that

Optical Chirpform Test Set

Q7606A/B

instrument, type, designation

complies with the provisions of the EMC Directive 89/336/EEC in accordance with EN50081-1 and EN50082-1 and Low Voltage Directive 73/23/EEC in accordance with EN61010.

ADVANTEST Corp.

Tokyo, Japan

ROHDE&SCHWARZ

Engineering and Sales GmbH
Munich, Germany

CAUTIONS OF Q7606A/B

1. CLASS 1 LASER PRODUCT Label (Only Q7606A)

The Q7606A is the product of the CLASS 1 LASER.

The accessories contains the following label.

| INTERNATIONAL LASER WARNING LABELS | | |
|---|--|--|
| JAPANESE | FOR: JAPAN | |
| クラス1レーザ製品 | クラス1レーザ製品 | |
| ENGLISH | FOR: UK NORWAY SWEDEN DENMARK BELGIUM NETHERLANDS | |
| CLASS 1 LASER PRODUCT | CLASS 1 LASER PRODUCT | |
| FRENCH | FOR: FRANCE BELGIUM SWITZERLAND | |
| APPAREIL LASER DE LA CLASSE 1 | APPAREIL LASER DE LA CLASSE 1 | |
| GERMAN | FOR: GERMANY BELGIUM SWITZERLAND AUSTRIA | |
| LASER KLASSE 1 | LASER KLASSE 1 | |
| SPANISH | FOR: SPAIN | |
| PRODUCTO LASER CLASE 1 | PRODUCTO LASER CLASE 1 | |
| ITALIAN | FOR: ITALY SWITZERLAND | |
| LASER CLASSE 1 | LASER CLASSE 1 | |
| FINNISH | FOR: FINLAND | |
| LUOKAN 1 LASER | LUOKAN 1 LASER | |
| <p>PLEASE NOTE SWITZERLAND MAY REQUIRE FRENCH, GERMAN, OR ITALIAN LABELING. BELGIUM MAY REQUIRE ENGLISH, FRENCH, OR GERMAN LABELING.</p> | | |
| MNS-E0168A | | |

Put a label on the place shown in the following illustration according to the useful language in your country.

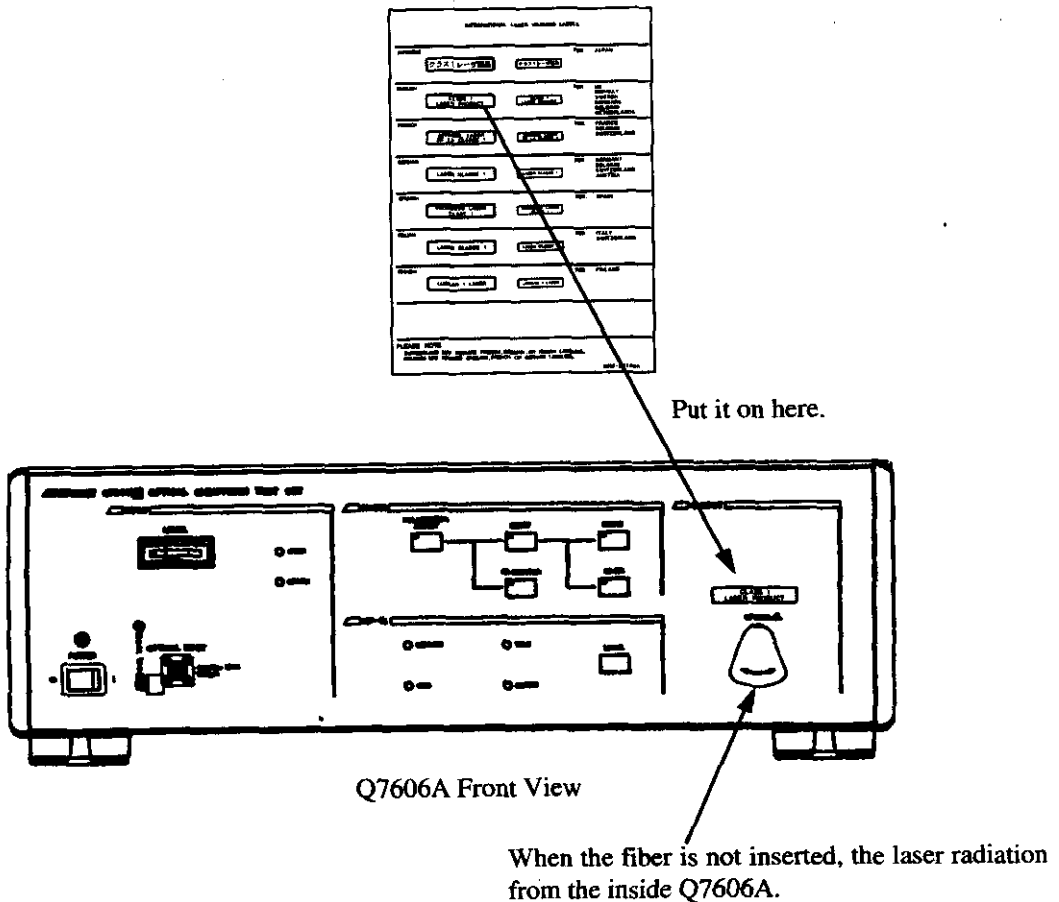

Q7606A Front View

Internal laser specifications
Wavelength: 1.55 μm
Power: 8 dBm or less

2. Maintenance

CAUTION: No operator serviceable parts inside. Servicing to be provided by trained individuals.

For the maintenance or the inspection of Q7606A/B's inside or the replacement of various parts other than fuse, contact your nearest ADVANTEST dealer.

PREFACE

To use the Q7606A/B safely, observe the following precautions:

- (1) The maximum allowable incident light power of the Q7606A/B is +10dBm. If optical power exceeding +10dBm is given to the Q7606A/B, it may give the Q7606A/B unrecoverable damages.
- (2) The Q7606A/B internally uses high voltages. To avoid electric shocks, do not open the frame cover when the power supply is on.
- (3) In this manual, the keys are expressed under the following conventions:

IM-MONITOR Q7606A/B panel keys

[[PROGRAM(RUN)]] R3753/65/67 panel keys

LOAD R3753/65/67 software keys (keys used in screen software menu)

TABLE OF CONTENTS

| | | |
|----------|--|------------|
| 1 | OVERVIEW | 1-1 |
| 1.1 | Product Overview | 1-1 |
| 1.2 | Configuration of the Q7606A/B | 1-2 |
| 1.3 | Accessories | 1-3 |
| 1.4 | Environment Conditions | 1-5 |
| 1.5 | Preparing to Power ON | 1-6 |
| 1.5.1 | Connecting Power Cable to the Q7606A/B | 1-6 |
| 1.5.2 | Power Cable | 1-6 |
| 1.5.3 | Fuse | 1-7 |
| 1.6 | Cleaning, Transportation, and Storage | 1-8 |
| 1.6.1 | Cleaning Connectors | 1-8 |
| 1.6.2 | Cleaning the Q7606A/B | 1-9 |
| 1.6.3 | Transporting the Q7606A/B | 1-9 |
| 1.6.4 | Storing the Q7606A/B | 1-9 |
| 1.7 | Optional Software Products for Measurement Support | 1-10 |
| 1.7.1 | Cautions for Using Optional Software Products | 1-10 |
| 1.7.2 | Optical Chirpform Measurement Software (an extra-cost option) | 1-10 |
| 2 | PANEL DESCRIPTIONS | 2-1 |
| 2.1 | Front Panel | 2-1 |
| 2.2 | Rear Panel | 2-3 |
| 3 | BASIC OPERATION GUIDELINE (MEASURING DYNAMIC CHIRP CHARACTERISTICS) | 3-1 |
| 3.1 | Overview | 3-1 |
| 3.2 | Configuring the Measurement System | 3-2 |
| 3.3 | Measurement | 3-2 |
| 3.3.1 | Setting the Sampling Oscilloscope | 3-3 |
| 4 | GPIB | 4-1 |
| 4.1 | Overview | 4-1 |
| 4.1.1 | Overview of GPIB | 4-1 |
| 4.1.2 | GPIB and the Q7606A/B's GPIB Specifications | 4-3 |
| 4.1.3 | Interface Functions | 4-4 |
| 4.1.4 | Connecting Component Devices | 4-5 |
| 4.1.5 | Description of the Q7606A/B Panel Controls Relating to GPIB | 4-5 |
| 4.2 | Service Request | 4-7 |
| 4.3 | GPIB Talker Format | 4-8 |
| 4.4 | GPIB Commands | 4-9 |
| 4.5 | Reading the Status Data Set in Q7606A/B | 4-12 |
| 4.6 | Sample Programs | 4-13 |

Table of Contents

| | | |
|--|---|------------|
| 4.6.1 | Setting the Q7606A/B | 4-13 |
| 4.6.2 | Reading Status Data Set in Q7606A/B and Correction Data | 4-13 |
| 4.6.3 | Standard Module | 4-14 |
| 5 | TROUBLESHOOTING | 5-1 |
| 6 | OPERATING PRINCIPLES | 6-1 |
| 6.1 | Operating Principles | 6-1 |
| 6.1.1 | Using the Mach-Zehnder Interferometer as a Lightwave Frequency Discriminator | 6-1 |
| 6.1.2 | Separating FM and IM Components | 6-2 |
| 6.1.3 | Interferometer Characteristics and Q7606A/B Operations | 6-3 |
| 6.2 | Block Diagram | 6-6 |
| 7 | SPECIFICATIONS | 7-1 |
| 7.1 | Q7606A/B Major Specifications | 7-1 |
| 7.1.1 | Measurement Functions | 7-1 |
| 7.1.2 | Input Characteristics | 7-1 |
| 7.1.3 | Input/Output Specifications | 7-2 |
| 7.1.4 | General Specifications | 7-2 |
| APPENDIX | A-1 | |
| A.1 | Glossary | A-1 |
| DIMENSIONAL OUTLINE DRAWING | EXT-1 | |

LIST OF ILLUSTRATIONS

| No. | Title | Page |
|-----|---|------|
| 1-1 | Power Cable | 1-6 |
| 1-2 | Fuse Holder | 1-7 |
| 1-3 | Connector Cleaning (1) | 1-8 |
| 1-4 | Connector Cleaning (2) | 1-8 |
| 1-4 | Connector Cleaning (3) | 1-9 |
| 1-6 | Connector Cleaning (4) | 1-9 |
| 2-1 | Front Panel | 2-1 |
| 2-2 | Rear Panel | 2-3 |
| 3-1 | Measurement System Configuration | 3-2 |
| 4-1 | GPIB Bus Line Configuration | 4-1 |
| 4-2 | GPIB Connector Pin Assignments | 4-3 |
| 6-1 | Lightwave Frequency-discriminate Characteristics of the Mach-Zehnder Interferometer | 6-1 |
| 6-2 | Switching Measurement Points of the Mach-Zehnder Interferometer | |
| | Lightwave Frequency Discriminator | 6-2 |
| 6-3 | Interferometer Characteristics Measured by RESET | 6-3 |
| 6-4 | Interferometer Characteristics Measured by IM+FM | 6-4 |
| 6-5 | Interferometer Characteristics Measured by IM-FM | 6-4 |
| 6-6 | Interferometer Characteristics Measured by IM-MONITOR | 6-5 |
| 6-7 | Q7606A/B Block Diagram | 6-6 |
| A-1 | Interference Characteristics and FSR of the Mach-Zehnder Interferometer | A-4 |
| A-2 | Typical Mach-Zehnder Interferometer Configuration | A-6 |

LIST OF TABLES

| No. | Title | Page |
|-----|---------------------------------|------|
| 1-1 | Standard Accessories List | 1-3 |
| 1-2 | Power Cable Options | 1-4 |
| 4-1 | GPIB Interface Functions | 4-4 |

1 OVERVIEW

1.1 Product Overview

The Q7606A/B is a lightwave modulation test set, used together with a digital sampling oscilloscope, to separately measure and evaluate the chirp (frequency-modulated/FM) and intensity-modulated (IM) components of incident laser light.

The Q7606A/B contains two sets of fiber-type Mach-Zehnder interferometers and their control circuits.

The Q7606A/B can selectively output the sum of or difference between the frequency-modulated/FM and IM components of the modulated incident light by switching the measurement mode. The sum (IM+FM) and difference (IM-FM) data are processed by the digital sampling oscilloscope and the personal computer to separate the chirp FM and IM components from each other, thus making it possible to evaluate the time-domain characteristics.

Features:

- (1) The Q7606A/B makes it possible to separate the frequency-modulated/FM and IM components from each other easily.
- (2) The Q7606A/B is equipped with two sets of built-in and fiber-type Mach-Zehnder interferometer.
- (3) The Q7606A/B is optimal for evaluating the chirp characteristics of an optical modulator (such as an LN or EA modulator).
- (4) The Q7606A/B is also available as a lightwave frequency discriminator for the lightwave frequency domain.

1.2 Configuration of the Q7606A/B

1.2 Configuration of the Q7606A/B

Measuring the dynamic chirp characteristics (time-domain characteristics of chirp) using the Q7606A/B requires an O/E converter, a digital sampling oscilloscope, and a personal computer. Software for measuring and evaluating the dynamic chirp characteristics is optionally available.

1.3 Accessories

Table 1-1 lists the standard accessories shipped with the Q7606A/B. If any of the accessories are damaged or missing, contact the nearest ADVANTEST Field Office or representative. Order new accessories by name.

Table 1-1 Standard Accessories List

| Name of accessory | Type name | Quantity | Remarks |
|-----------------------------|------------|----------|------------------------|
| Power cable | * | 1 | |
| GPIB connection cable | 408JE-1P5 | 1 | |
| Fuses | 21802.5 | 2 | AC250V/2.5A |
| Q7606A/B Operation manual | EQ7606A/B | 1 | English |
| CLASS 1 LASER PRODUCT label | MNS-E1068A | 1 | Put it on Q7606A only. |

- * 1: Depends on the type specified when purchasing the Q7606A/B.
 There are 11 types of power cables available (see Table 1-2).
 You can order power cables by model number or by option number.

1.3 Accessories

Table 1-2 Power Cable Options

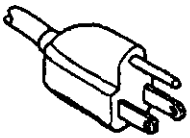
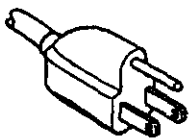
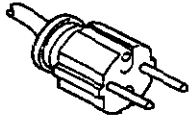
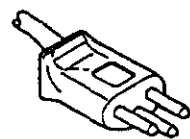
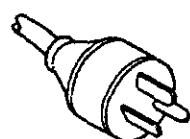
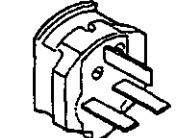
| Plug configuration | Standards | Rating, color and length | Model number (Option number) |
|---|--|-------------------------------------|--|
|  | JIS: Japan Law on Electrical Appliances | 125 V at 7 A Black 2 m (6 ft) | Straight: A01402 Angled: A01412 |
|  | UL: United States of America CSA: Canada | 125 V at 7 A Black 2 m (6 ft) | Straight: A01403 (Option 95) Angled: A01413 |
|  | CEE: Europe DEMKO: Denmark NEMKO: Norway VDE: Germany KEMA: The Netherlands CEBEC: Belgium OVE: Austria FIMKO: Finland SEMKO: Sweden | 250 V at 6 A Gray 2 m (6 ft) | Straight: A01404 (Option 96) Angled: A01414 |
|  | SEV: Switzerland | 250 V at 6 A Gray 2 m (6 ft) | Straight: A01405 (Option 97) Angled: A01415 |
|  | SAA: Australia, New Zealand | 250 V at 6 A Gray 2 m (6 ft) | Straight: A01406 (Option 98) Angled: ----- |
|  | BS: United Kingdom | 250 V at 6 A Black 2 m (6 ft) | Straight: A01407 (Option 99) Angled: A01417 |

1.4 Environment Conditions

- (1) Since the Q7606A/B is a precision measurement device, avoid installing it in a position where it is exposed to dust, direct sunlight, corrosive gas, or vibration. Be sure to use the Q7606A/B in conditions of an ambient temperature of 10°C to 40°C and a relative humidity of 85% or less.
- (2) Although the Q7606A/B has been designed to be durable against AC line noise, care should be taken to minimize the AC noise at the site where the Q7606A/B is installed. If necessary, use a noise elimination filter.
- (3) The Q7606A/B can be used safely under the following conditions:
 - Altitude of up to 2000m
 - Installation Categories II
 - Pollution Degree 2
- (4) Never block these areas as the resulting internal temperature rise will affect measurement accuracy.
 - Avoid operation in the following areas.
 - Use a noise cut filter when there is a large amount of noise riding on the power line.

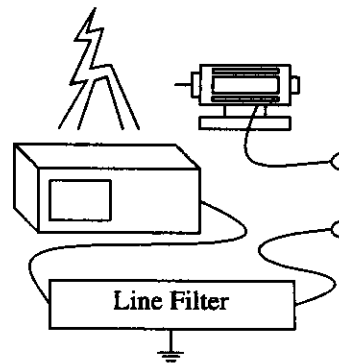
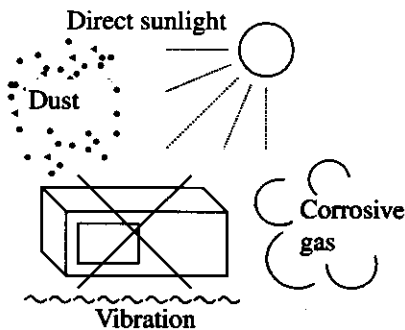

- Keep the rear panel 10cm away from the wall

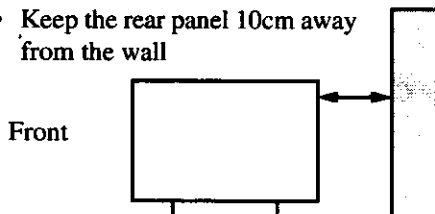

1.5 Preparing to Power ON

1.5 Preparing to Power ON

1.5.1 Connecting Power Cable to the Q7606A/B

Make sure that the POWER switch on the Q7606A/B front panel is set to OFF, and then connect the attached power cable to the AC LINE connector on the rear panel of the Q7606A/B. The permitted power voltage range is 90 to 250 V, and the permitted power frequency range is 48 to 66 Hz.

1.5.2 Power Cable

CAUTION:

1. Use a power cable rated for the voltage in question. Be sure however to use a power cable conforming to safety standards of your nation when using a product overseas (see Table 1-2).
2. Be sure to plug the power cable into an electrical outlet which has a safety ground terminal. Grounding will be defeated if you use an extension cord which does not include a safety ground terminal.
3. Turn the MAIN POWER switch (on the rear panel) and the POWER switch (on the front panel) off prior to connecting the power cable.

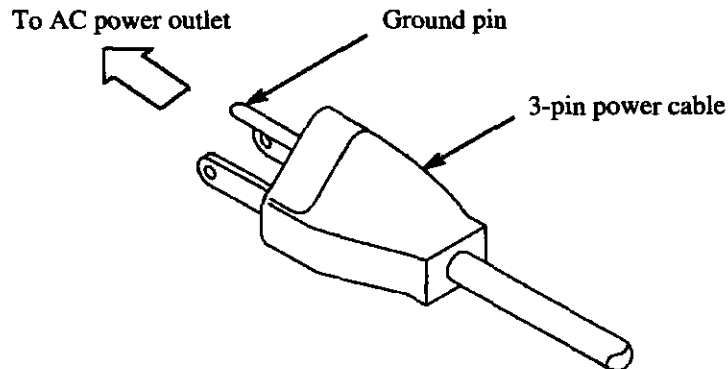

Figure 1-1 Power Cable

1.5.3 Fuse

To replace the fuse, set the POWER switch to OFF and disconnect the power cable from the AC LINE connector. The fuse holder can be taken off by pulling the fuse holder notch at the top of the AC LINE connector. When replacing the fuse, be sure to use the type provided (DFT-AA2R5A-1).

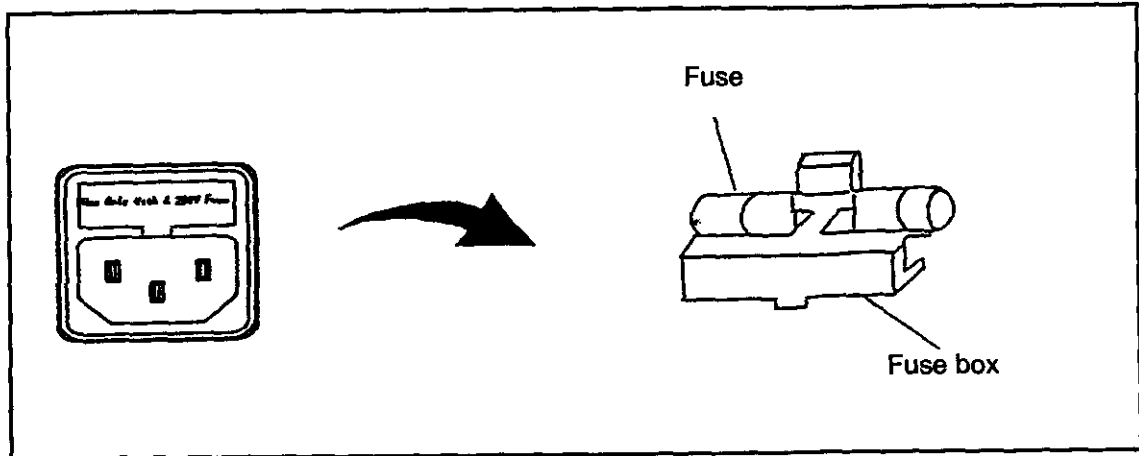

Figure 1-2 Fuse Holder

1.6 Cleaning, Transportation, and Storage

1.6 Cleaning, Transportation, and Storage

1.6.1 Cleaning Connectors

If the optical fiber connector of the Q7606A/B is stained, this may cause a reduction in output signals. Keep the optical fiber connector clean by wiping it with a soft cloth moistened with alcohol.

If the optical fiber connector is stained, clean it using the following steps:

- (1) Out of the four screws fixing the optical fiber connector receptacle on the front panel, remove two screws: the upper left and lower right ones. (See Figure 1-3.)
- (2) Gently pull out the receptacle approximately 3 cm. (Do not pull it forcibly, or the optical-fiber cable may be damaged.) (See Figure 1-4.)
- (3) Loosen the connector screw on the back of the receptacle and disengage the receptacle from the connector. (See Figure 1-4.)
- (4) Clean the connector with a soft cloth moistened with alcohol. Take care not to damage the connector. (See Figure 1-6.)
- (5) Engage the cleaned connector with the receptacle and tighten the screw.
- (6) Attach the receptacle to the front panel and fix it with the two screws.

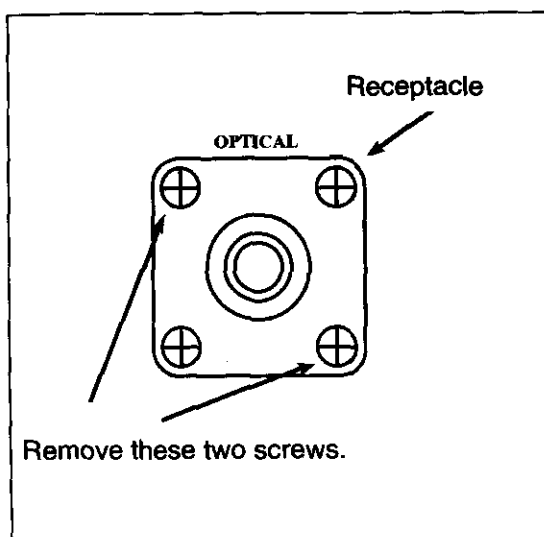

Figure 1-3 Connector Cleaning (1)

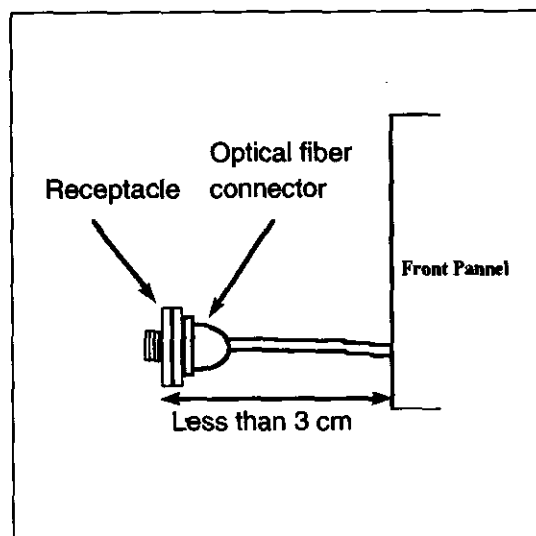

Figure 1-4 Connector Cleaning (2)

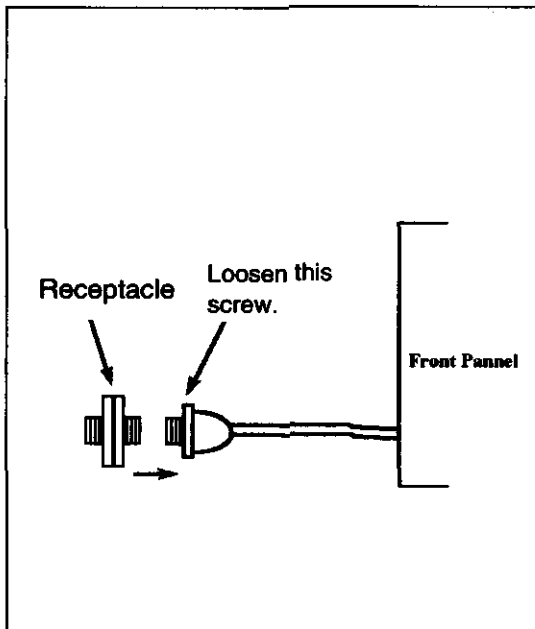

Figure 1-4 Connector Cleaning (3)

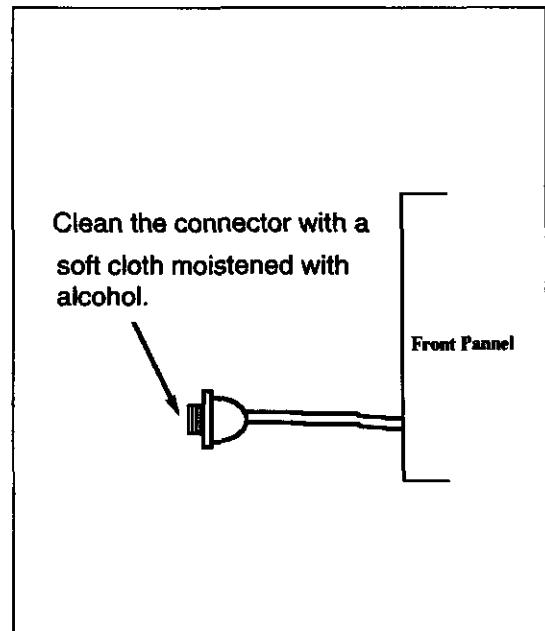

Figure 1-6 Connector Cleaning (4)

1.6.2 Cleaning the Q7606A/B

When cleaning the Q7606A/B, wipe it with a soft cloth moistened with alcohol. Do not use a solvent such as benzene, toluene, or acetone that may damage plastics.

1.6.3 Transporting the Q7606A/B

When transporting the Q7606A/B, pack it in the same materials used for shipment. If these are no longer available, wrap the Q7606A/B with sufficient cushioning, and place it in a carton with a board thickness of 5mm or more. Place the accessories on it, fill the space with cushioning materials, close the carton, and bind the carton with packing cords.

1.6.4 Storing the Q7606A/B

The storage conditions for the Q7606A/B are: a temperature of -20°C to $+60^{\circ}\text{C}$ and a relative humidity of 90% or less. If the Q7606A/B is not in use for a long time, cover it with a vinyl sheet or place it in a carton and store it in a dry place out of direct sunlight.

1.7 Optional Software Products for Measurement Support

1.7 Optional Software Products for Measurement Support

The following software products are optionally available:

Optical Chirpform Measurement Software (an extra-cost option)

When necessary, please contact us.

1.7.1 Cautions for Using Optional Software Products

ADVANTEST or its licensee(s) hold the copyright for the software products listed above, which are protected under Japan's Copyright Act and international treaties. Users must treat these products in the same manner as copyright books or music recordings. Users are allowed to copy the software products solely for the purpose of backup or storage.

ADVANTEST or its licensee(s) shall not take any responsibility for any kind of damage (including, but not limited to, the loss of business profits, interruptions of business, loss of business information, or other financial disadvantages) caused by the usage or unavailability of any of these software products. This will also apply even if ADVANTEST has been notified of the possibility of such damage. In any case, ADVANTEST's responsibility shall be limited to the amount paid by the user for the associated software product(s).

1.7.2 Optical Chirpform Measurement Software (an extra-cost option)

This is a special-version software product for measuring the time-domain dynamic chirp of optical modulated signals. The standard system configuration for using this software product is given below.

- Q7606A/B Optical Chirpform test set (this instrument)
- Digital sampling oscilloscope Tektronix 11801B, HP83480A (O/E converter or optical input head)
- PC/AT-compatible personal computer
- Microsoft Windows 95 or upper
- National Instruments general purpose interface bus (GPIB) board (Windows 95 edition) and its driver software

This software product is an application software program running under Microsoft Windows 95. When using peripheral units such as a printer, they must be used in the Windows 95 environment. Windows 3.1 or lower is not suitable.

Windows 95 is the trademark of Microsoft Corp.

2 PANEL DESCRIPTIONS

2.1 Front Panel

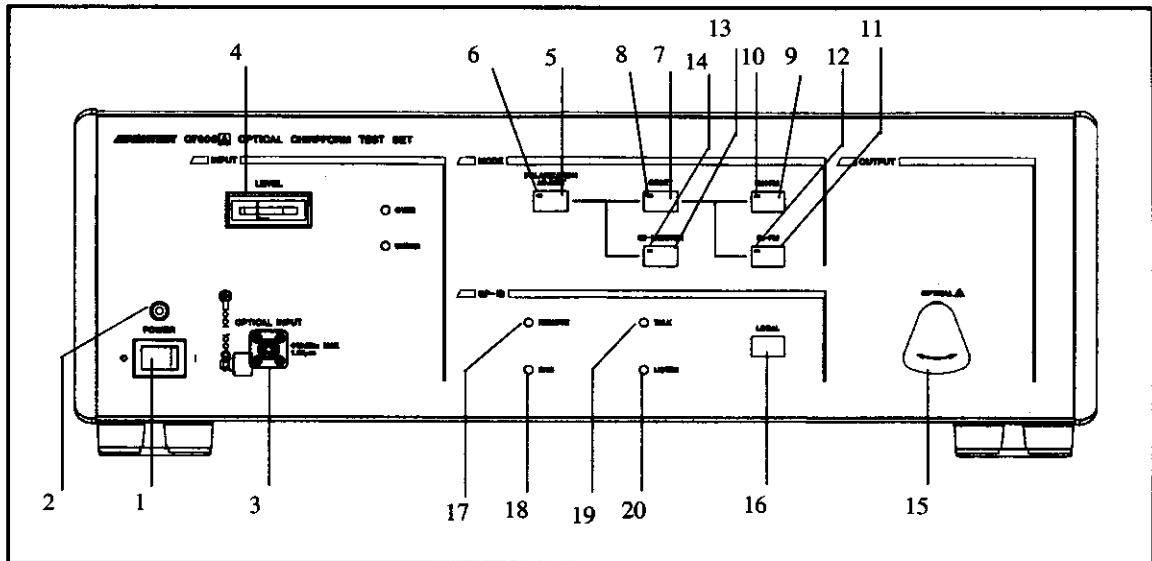

Figure 2-1 Front Panel

1. **POWER** switch Use this switch to turn the Q7606A/B power ON/OFF.
2. **POWER** indicator This indicator remains on while the Q7606A/B **POWER** switch is ON.
3. **OPTICAL INPUT** connector This connector receives the incident light to be measured. It is internally connected with a PC-polished FC connector.

CAUTION: The FC connector to be used must be thoroughly cleaned.

4. **Level** meter Indicates the intensity of the interfering light input to the interferometer. This intensity varies depending on the incident light power and polarization state.
5. **POLARIZATION ADJUST** Key This key is used to turn the operation mode (of the built-in polarization controller) on or off. When turned on, the state of incident light polarization is optimally adjusted by the built-in polarization controller prior to performing a RESET.
6. **POLARIZATION ADJUST** Indicator Lit when the operation mode (of the built-in polarization controller) is turned on.
7. **RESET** key Use this switch to reset the optical interferometer. The interferometer, when reset, reads the information (power and polarization) of the incident light.
After operating the **OUTPUT SELECT** or **IM-MONITOR** key

2.1 Front Panel

- switch, RESET must be executed at least once before the Q7606A/B can enter the IM+FM or IM-FM mode. In addition, be sure to execute RESET after the incident light has changed its state (power or polarization), because the optical interferometer is controlled on the basis of information from the RESET execution.
8. **RESET** indicator While this RESET is being executed, this indicator flashes continuously. When RESET is completed, this indicator remains on and the Q7606A/B enters the IM+FM mode.
 9. **IM+FM** key Use this key switch to set the built-in optical interferometer to the mode in which the incident light IM and chirp/FM components are output with the same phase. RESET must be executed prior to operating this switch. This mode is also set automatically after RESET is completed.
 10. **IM+FM** indicator This indicator flashes during adjustment of the built-in optical interferometer, and remains on when the interferometer is locked
 11. **IM-FM** key Use this key switch to set the built-in optical interferometer to the mode in which the incident light IM and chirp/FM components are output with the inverse phase. RESET must be executed prior to operating this switch.
 12. **IM-FM** indicator This indicator flashes during adjustment of the built-in optical interferometer, and remains on when the interferometer is locked.
 13. **IM-MONITOR** key Use this key switch to set the built-in optical interferometer to the mode in which only the incident light IM components are output. Wait approximately 20 seconds until output from the optical interferometer is stabilized.
 14. **IM-MONITOR** indicator This indicator remains on when IM-MONITOR mode is selected.
 15. **OPTICAL OUTPUT** connector This connector provides optical output from the fiber-type interferometer.
 16. **LOCAL** key Use this switch to change the Q7606A/B to the local mode from the remote mode using GPIB.
 17. **REMOTE** indicator This indicator remains on while the Q7606A/B is in the remote mode using GPIB.
 18. **SRQ** indicator This indicator is on when the Q7606A/B is sending an SRQ.
 19. **TALK** indicator This indicator remains on while the Q7606A/B is in the talk mode.
 20. **LISTEN** indicator This indicator remains on while the Q7606A/B is in the listen mode.

2.2 Rear Panel

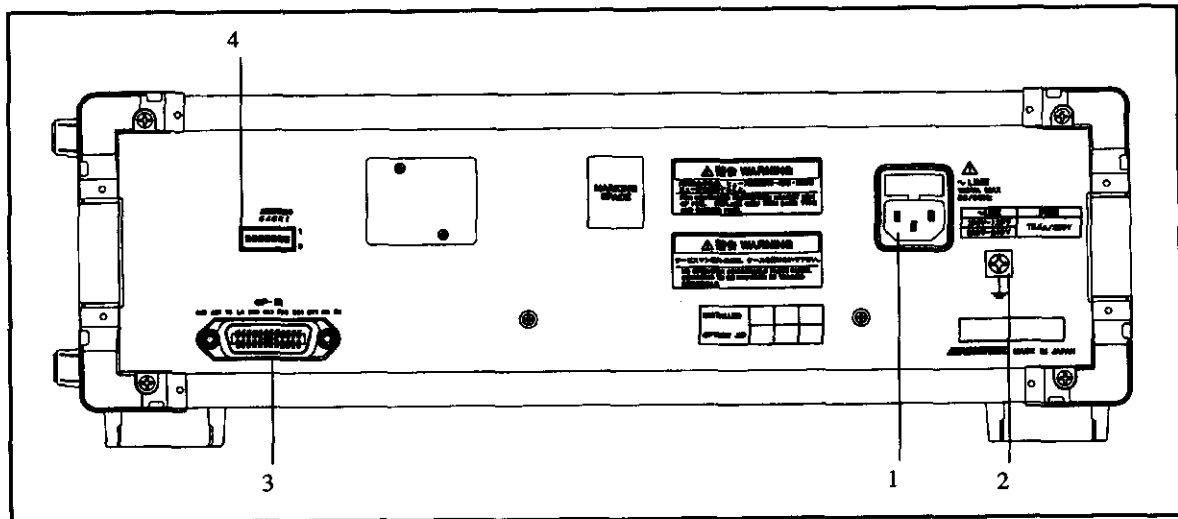

Figure 2-2 Rear Panel

- | | |
|------------------------|--|
| 1. Power connector | Connect the attached power cable to this connector. This connector has a fuse holder. Be sure to check the correct rating when replacing a fuse. |
| 2. Ground terminal | Connect this terminal to an external ground. |
| 3. GPIB connector | Connect a GPIB cable to this connector. |
| 4. GPIB address switch | Set the Q7606A/B GPIB address in this switch before turning the Q7606A/B power on. |

3 BASIC OPERATION GUIDELINE (MEASURING DYNAMIC CHIRP CHARACTERISTICS)

3.1 Overview

This section describes how to measure and evaluate the dynamic chirp characteristics of optical signals, using the Q7606A/B, a sampling oscilloscope, and a personal computer, as well as the optionally available optical chirp measurement software

This software allows one to:

- measure the optical signal chirp characteristics
- store, read, or print the measurement data

(1) Execution environment

This software program only runs under Microsoft Windows 95. It is not available under MS-Windows 3.1 or lower.

GPIB control and measurement using this program require a PC/AT-compatible personal computer, a National Instruments GPIB board (for Windows 95), and its driver software. Any other type of personal computer or GPIB board is not suitable.

For the operating instructions, refer to the PQ76000401-FK Optical Chirpform Measurement software Operation Manual.

3.2 Configuring the Measurement System

3.2 Configuring the Measurement System

This section explains the typical system configuration for dynamic chirp measurement using the optical chirp measurement software.

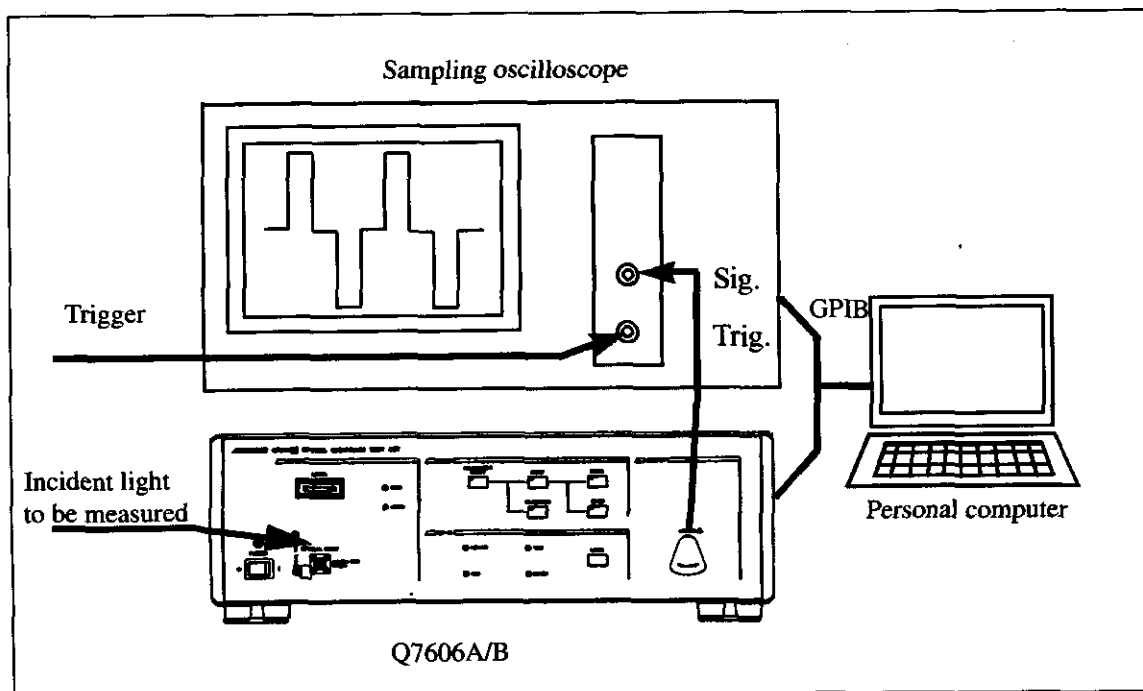

Figure 3-1 Measurement System Configuration

Connect the Q7606A/B, personal computer (controller), and sampling oscilloscope via GPIB cables. The Q7606A/B and sampling oscilloscope must have individual GPIB addresses.

Input the incident light to be measured from the optical input connector on the Q7606A/B front panel. Connect the wide-band optical output of the Q7606A/B to the sampling oscilloscope input.

CAUTION: *If the sampling oscilloscope does not accept optical input, insert an optional O/E converter which has a sufficient response frequency band between the Q7606A/B wide-band optical output connector and the sampling oscilloscope input connector.*

The optical insertion loss of the Q7606A/B is approximately 10dB. If necessary, use an amplifier when the optical power level supplied to the sampling oscilloscope or O/E converter is too low.

For dynamic chirp measurement, use the waveform data from the sampling oscilloscope for calculation. The trigger signal input to the sampling oscilloscope trigger input connector must be of a type allowing display of the measured light waveform data.

CAUTION: Chirp calculation cannot be carried out with visual patterns.

3.3 Measurement

3.3.1 Setting the Sampling Oscilloscope

Adjust the time and level axes on the sampling oscilloscope so that the necessary waveform data can be displayed.

Dynamic chirp measurement uses the sampling oscilloscope waveforms from the Q7606A/B in two modes: IM+FM and IM-FM. Fluctuation in the time or level axis might cause an error in the dynamic chirp measurement. Therefore, adjust these axes to ensure correct measurement of the waveform data. The dynamic chirp measurement also uses the difference between data of these two modes. Averaging should be done for the measurement data to ensure correct measurement of the difference.

The Q7606A/B's built-in Mach-Zehnder interferometer input section has a polarizer. Adjust the light to be measured so that it has a stable polarization state. If the polarization state of the light to be measured is unstable, it is recognized as an IM component.

The dynamic chirp measurement results are displayed with time along the abscissa and the chirp or intensity along the ordinate. This means that the chirp characteristics which are synchronized with the IM characteristics can be measured.

For details of operations, refer to the PQ76000401-FK Optical Chirpform Measurement software Operation Manual.

4 GPIB

4.1 Overview

The Q7606A/B allows remote control through the built-in IEEE 488-1987 measurement bus called GPIB (general purpose interface bus).

4.1.1 Overview of GPIB

The GPIB is an interface system allowing to configure an automatic measurement system by connecting the measurement device, controller, peripheral units, etc., through simple bus cables.

The GPIB system is advantageous in that it is more expandable than conventional interface systems, provides electrical, mechanical, and functional compatibility with other manufacturers' products, and is applicable to various system configurations ranging from those containing only one bus cable to those with high-level functions.

To use the GPIB system, first set an address for each of component devices connected to the bus line. Each component device can be assigned one or more roles from the three roles: controller, talker, or listener. Only one talker can send data to the bus line, and plural listeners can receive it. The controller specifies the talker and listener addresses, transfers data from talker to listeners, or can itself become a talker to set measurement conditions, etc. for the listeners.

Data are transferred asynchronously both ways between devices via eight data lines in the bit-parallel, byte-serial form. Because this is an asynchronous system, it is possible to mix high-speed and low-speed devices in the same system.

Data (messages) transferred between the devices include measurement data, measurement conditions (programs), various commands, and so forth; they are in ASCII code.

In addition to eight data lines, there are three handshake lines for transferring asynchronous data between devices, and five control lines for controlling the information flow on the bus.

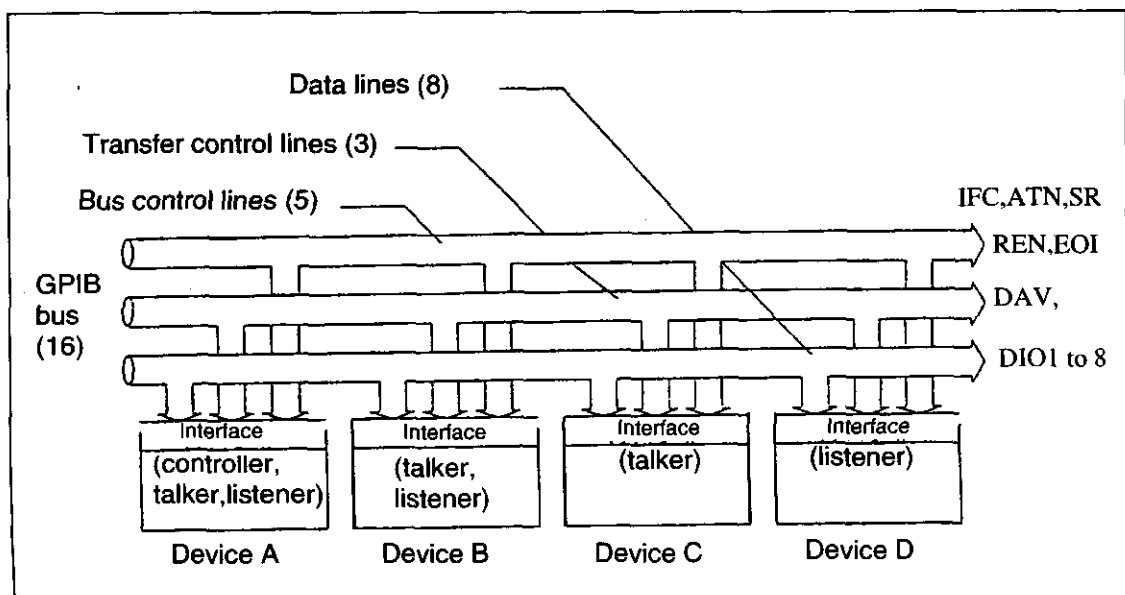

Figure 4-1 GPIB Bus Line Configuration

4.1 Overview

(1) The handshake lines transfer the following signals:

| | |
|---------------------------|---|
| DAV (Data Valid) | Indicates the validity of data. |
| NRFD (Not Ready For Data) | Indicates readiness to receive data. |
| NDAC (Not Data Accepted) | Indicates completion of data reception. |

(2) The control line transfers the following signals:

| | |
|-----------------------|---|
| ATN (Attention) | Used to recognize the signal on the data lines as an address, command, or neither of the two. |
| IFC (Interface Clear) | Used to clear the interface. |
| EOI (End of Identify) | Used at the end of information transfer. |
| SRQ (Service Request) | Used by any device to ask the controller for a service. |
| REN (Remote Enable) | Used for remote control of devices applicable to remote programming. |

4.1.2 GPIB and the Q7606A/B's GPIB Specifications

- Applied standards : IEEE 488-1978
- Code used : ASCII
- Logic level : Logical "0" (HIGH) ... +2.4 V or more
Logical "1" (LOW) ... +0.4 V or less
- Driver specifications : Open-collector format (except EOI or DAV)
Output voltage in LOW ... +0.4V or less, 48 mA
Output voltage in HIGH ... +2.4V or more, -5.2 mA
- Receiver specifications : LOW for +0.6 V or less, HIGH for +2.4 V or more
- Address specification : 31 talker/listener addresses can be set by the ADDRESS switch.
- Cable length : The total bus cable length in a single bus system should not exceed $n \times 2m$, where n = the number of devices to be connected, including the GPIB controller. In no case should the cable length exceed 20m.
- Connector : 24-pin GPIB connector 57-20240-D35A (equivalent to Amphenol's products)

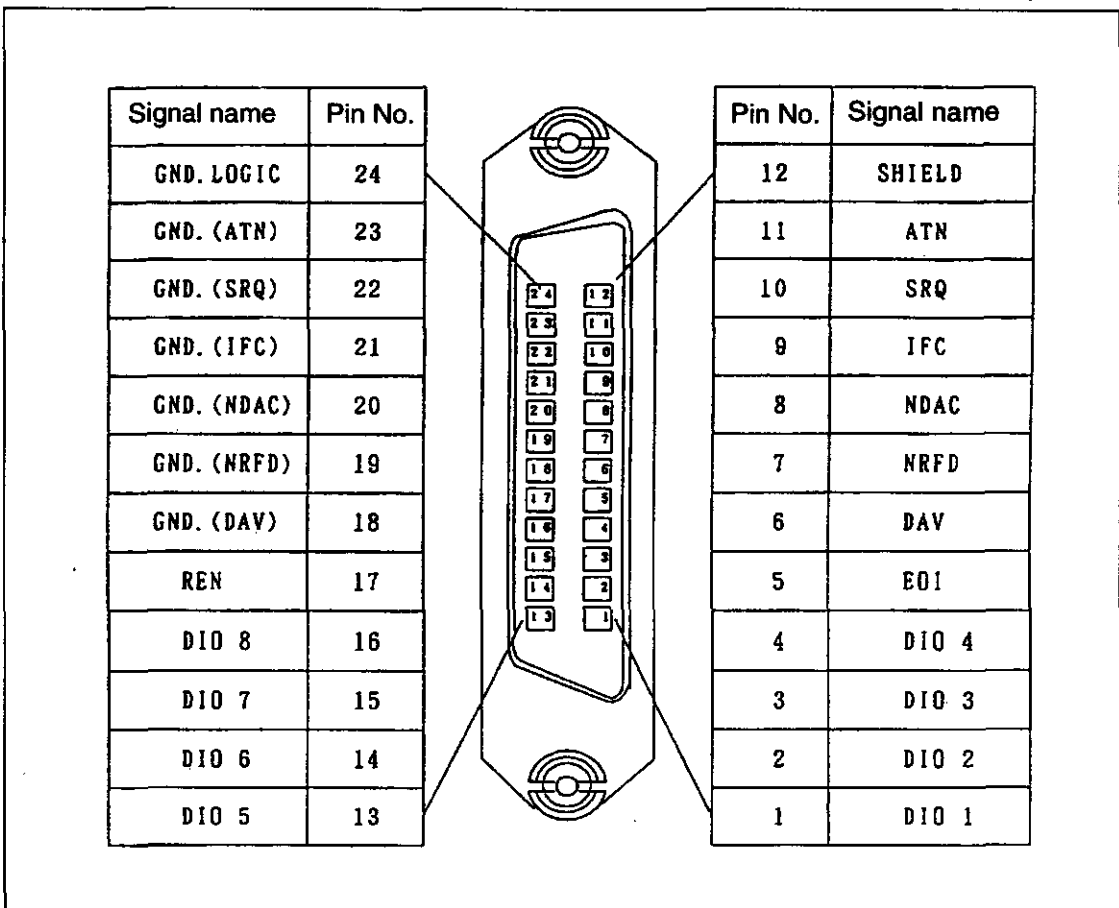

Figure 4-2 GPIB Connector Pin Assignments

4.1 Overview

4.1.3 Interface Functions

Table 4-1 shows the GPIB interface functions.

Table 4-1 GPIB Interface Functions

| Code | Description |
|------|--|
| SH1 | Source handshake function |
| AH1 | Acceptor handshake function |
| T6 | Basic talker function, serial poll function, and function for talker reset by listener specification |
| L4 | Basic listener function and function for listener reset by talker specification |
| SR1 | Service request function |
| RL1 | Remote function |
| PP0 | No parallel function provided |
| DC1 | Device clear function |
| DT1 | Device trigger function |
| C0 | No controller function provided |
| E2 | Try-state output |

4.1.4 Connecting Component Devices

The GPIB system consists of several devices. This section gives the precautions to be observed when configuring the system.

- (1) Before connecting the component devices, check their states and functions. (Refer to the relevant device's instruction manual.)
- (2) Care should be taken to make the cables connecting the measurement device and the bus cable connecting the controller as short as possible. The bus cable should not exceed the rated length. The total bus cable length in a single bus system should not exceed $n \times 2\text{m}$, where n = the number of devices to be connected, including the GPIB controller. In no case should the cable length exceed 20m.

ADVANTEST optionally provides the following standard bus cables

Standard bus cables:

| Length | Name |
|--------|-----------|
| 0.5m | 408JE-1P5 |
| 1m | 408JE-101 |
| 2m | 408JE-102 |
| 4m | 408JE-104 |

- (3) The bus cable connectors are of the piggy-back type, i.e., each one has both male and female sides. Up to two such connectors can be used in a stack.

CAUTION: *Do not stack three or more connectors. Be sure to fix the connectors securely with fixing screws.*

- (4) Before turning the component devices' power ON, check their power conditions, installation conditions, and if necessary, set conditions.

CAUTION: *All the component devices connected to the bus must be powered. If any of the component devices are not powered ON, the whole system's operations are not guaranteed.*

4.1.5 Description of the Q7606A/B Panel Controls Relating to GPIB

- LOCAL** key Pressing this key while the Q7606A/B is in remote control mode (the REMOTE lamp is on) causes the Q7606A/B to cancel external controls and allows entries from the panel. The Q7606A/B is in the local mode immediately after it is powered.
- REMOTE** indicator Remains on while the Q7606A/B is in the remote control mode.
- SRQ** indicator Remains on while the Q7606A/B is transmitting a service request.

4.1 Overview

| | |
|----------------------------|--|
| TALK indicator | Remains on while the Q7606A/B is in the talker mode. |
| LISTEN indicator | Remains on while the Q7606A/B is in the listener mode. |
| GPIB address switch | Before turning the Q7606A/B power ON, set the GPIB address on the address switch on the Q7606A/B rear panel. |

4.2 Service Request

The Q7606A/B sends a service request (SRQ) to the controller when it has been placed in the S0 mode and then "1" has been set to the corresponding bits of the status byte.

After the Q7606A/B has sent a service request, the controller sends the status byte by serial polling.

Status byte

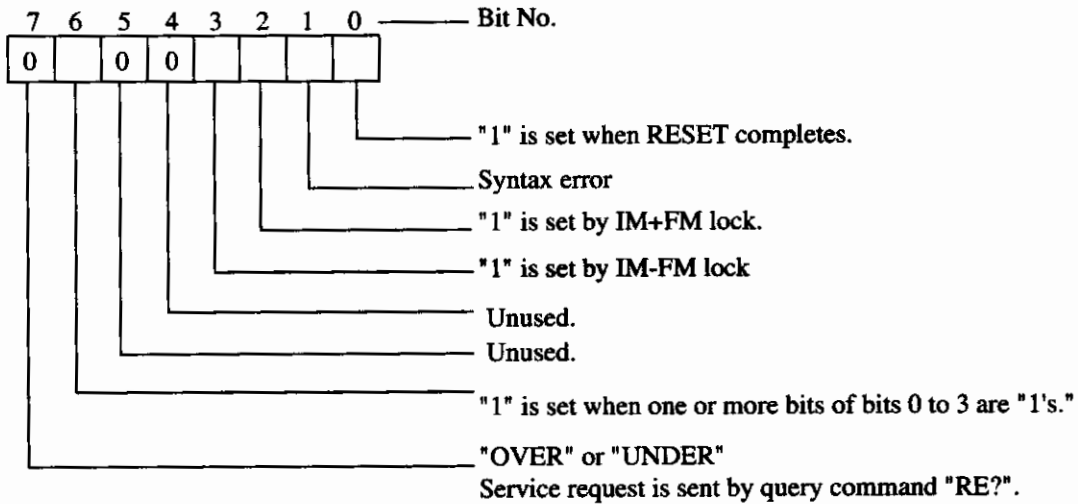

If an "ATN" request makes an interrupt during message transfer between devices, the previous states are cleared.

4.3 GPIB Talker Format

4.3 GPIB Talker Format

The talker format is in ASCII code. Read the talker data by issuing a read command.

When data is plural:



When data is not plural:



SD: String delimiter (Set by SLn.)

BD: Block delimiter (Set by DLn.)

Whether or not the data is plural is determined according to the read command. Refer to the explanation of read commands.

4.4 GPIB Commands

This section gives a list of GPIB commands, followed by their descriptions.

| No. | Code | Function |
|-----|------|--|
| 1 | C | Resets the Q7606A/B. |
| 2 | DLn | Sets the block delimiter. |
| 3 | SLn | Sets the string delimiter. |
| 4 | BZn | Sets the buzzer. |
| 5 | MDn | Sets the Q7606A/B measurement mode. |
| 6 | AJn | Turns the Polarization Controller on or off. |
| 7 | Sn | Sets SRQ. |
| 8 | CS | Clears the status. |

A maximum of 40 characters can be set at one time.

(1) C

| | | |
|-------------|--|--|
| Function | Initializes the Q7606A/B states. | |
| Parameters | None. | |
| Description | This command initializes the delimiters, buzzer, OUTPUT SELECT, and SRQ. | |
| | Item | State |
| | Block delimiter | Outputs EOI together with CRLF and LF. |
| | String delimiter | "," |
| | Buzzer | On |
| | OUTPUT SELECT | Sets HIGH-SENS. |
| | SRQ | Not sending SRQ. |

(2) DLn

| | |
|-------------|--|
| Function | Sets the block delimiter mode. |
| Parameters | n = 0 CR/LF + EOI n = 1 LF only n = 2 EOI only |
| Description | This command indicates the end of data. The specified delimiter is added to the data regardless of the number of data. |

4.4 GPIB Commands

(3) SLn

| | |
|-------------|--|
| Function | Sets the string delimiter mode. |
| Parameters | n = 0 " n = 1 _ (Space) n = 2 CRLF |
| Description | When an output request is issued, the output format is ASCII and the data consists of two or more, the specified string delimiters are added to the output data. |

(4) BZn

| | |
|-------------|---|
| Function | Sets the buzzer. |
| Parameters | n = 0 Buzzer off n = 1 Buzzer on |
| Description | This command is used to set the buzzer on or off. |

(5) MDn

| | |
|-------------|--|
| Function | Sets the measurement mode. |
| Parameters | n = 0 Executes RESET. n = 1 Executes IM+FM. n = 2 Executes IM-FM. n = 3 Executes IM-MONITOR. |
| Description | This command sets the Q7606A/B measurement mode. IM+FM or IM-FM cannot be executed unless RESET is executed at least once. RESET is cleared by IM-MONITOR. |

(6) AJn

| | |
|-------------|---|
| Function | Sets the Polarization Controller mode. |
| Parameters | n = 0 Disabled. n = 1 Enabled. (Default value) |
| Description | Sets whether or not the polarization Controller is enabled when a RESET is carried out. |

(7) Sn

| | |
|-------------|--|
| Function | Sets SRQ. |
| Parameters | n = 0 Sends SRQ. n = 1 SRQ is not sent. |
| Description | When S0 is set, a service request is issued. |

(8) CS

| | |
|-------------|---|
| Function | Clears the status. |
| Parameters | None. |
| Description | This command clears those bits that are set to "1" in the status. |

4.5 Reading the Status Data Set in Q7606A/B

4.5 Reading the Status Data Set in Q7606A/B

The status data set in the Q7606A/B can be read out with the following GPIB commands:

| Code | Function | Responses |
|------|---|----------------|
| DL? | Sets the block delimiter. | 0, 1, 2 |
| SL? | Sets the string delimiter. | 0, 1, 2 |
| BZ? | Sets the buzzer. | 0, 1 |
| MD? | Sets the operation mode. (RESET, IM+FM, IM-FM, IM-MONITOR) | 0, 1, 2, 3, -1 |
| AJ? | Sets the polarization controller mode. | 0, 1 |

After sending one of the above codes to the Q7606A/B, the response data is read out from the Q7606A/B. The number returned as the response corresponds to the parameter of the same value in the associated GPIB command. The case when "-1" is returned for the MD? command indicates that no operation mode has been set for the Q7606A/B.

4.6 Sample Programs

This section describes sample programs using the Visual Basic 5.0.

4.6.1 Setting the Q7606A/B

| | |
|-----------------------------|---|
| Dim Q7606AB as Integer | |
| Q7606AB=3 | Set the GPIB address (for the Q7606A/B) to 3. |
| gp_init | Initializing the GPIB board |
| remote(1) | Starting the REMOTE operation |
| Call OUTPUT(Q7606AB, "MD0") | Sends "MD0" to the Q7606A/B. |
| . | |
| . | |
| . | |
| Call gp_close | Terminating GPIB operation |

4.6.2 Reading Status Data Set in Q7606A/B and Correction Data

| | |
|-----------------------------|---|
| Dim Q7606AB as Integer | Declaring GPIB address variables (for the Q7606A/B) |
| Dim Ans as String | Declaring set state constant |
| Q7606AB=3 | Setting GPIB address (for the Q7606A/B) to 3 |
| Call gp_init | Initializing the GPIB board |
| remote(1) | Starting the REMOTE operation |
| Call OUTPUT(Q7606AB, "MD?") | Requests with the query "MD" which is used to read the settings. |
| NUM=1000 | Specifying the variable buffers. |
| Call ENTER_B(Q7606AB) | Reading data from the Q7606A/B |
| Ans=Trim(RD) | Deleting the space. |
| Debug.Print Ans | Displaying responses on the Debug window. |
| . | |
| . | |
| . | |

4.6 Sample Programs

4.6.3 Standard Module

To execute the programs shown in Sections 4.6.1 and 4.6.2, the following program is required as the standard module.

```

Global RD As String           'Buffer used with the query commands
Global NUM&                  'Number of data used with the query commands

Public Sub gp_init()

    bd = ilfind("GPIB0")
    If bd < 0 Then Call finderr
    If ilsic(bd) And EERR% Then Call error

End Sub

Public Sub remote(flag As Integer)
    If (ilsre(bd, flag) And EERR%) Then Call error
End Sub

Function OUTPUT(Adrs%, ByVal Cmd As String) As Integer
    'Simplified settings of GPIB
    Static cmd$

    cmd$ = Chr(UNL) + Chr(MTA) + Chr(MLA + Adrs%)
    If ilcmd(bd, cmd$, 3) And EERR% Then Call error
    If ilwrt(bd, Cmd, Len(Cmd)) And EERR% Then Call error
    OUTPUT = OK
End Function

Function ENTER_B(Adrs%) As Integer
    Static cmd$

    cmd$ = Chr(UNL) + Chr(MLA) + Chr(MTA + Adrs%)
    If ilcmd(bd, cmd$, 3) And EERR% Then Call error
    RD$ = Space$(NUM&)
    If ilrd(bd, RD$, Len(RD$)) And EERR% Then Call error
    ENTER_B = OK
End Function

Public Sub gp_close()
    If ilsic(bd) And EERR% Then Call error
    If ilonl(bd, 0) And EERR% Then Call error
End Sub

```

5 TROUBLESHOOTING

If a problem occurs, read this section before contacting ADVANTEST for repairs. This section may also provide reference information for measurement.

| Trouble | Solutions |
|--|--|
| The POWER indicator does not go on when the Q7606A/B is powered ON. | Check that the power cable is correctly connected. If the power is correctly supplied, check the fuse. |
| The panel operations are not accepted. | The Q7606A/B may have been placed in REMOTE mode by a GPIB command. If so, place it in the LOCAL mode using the LOCAL key. |
| No optical input is given, but the level meter is swinging. | Immediately after the Q7606A/B is powered ON, the conditions are not stable, and the level meter may swing. The level goes down after a while. |
| The level meter does not swing when an optical-fiber cable is connected. | Check whether the incident light level is too low. In addition, the level meter may also not swing when the incident light polarization state does not match the internal interferometer. Perform a RESET with POLARIZATION ADJUST ON , and adjust the level meter. The optical input connector should be connected with a PC-polished connector inside the Q7606A/B. The input level may also be lowered when the optical input connector is stained. Use a connector that has been well cleaned. |
| RESET does not complete. | The incident light level may be too low. Check the incident light level and optical fiber connectors. |
| IM+FM is not locked after RESET is over. | Make sure that the incident light is laser light of 1.55 μm band. The Q7606A/B's built-in interferometers have special parts for 1.55 μm band laser light. The interferometers do not work as frequency discriminators when the incident light is not of the 1.55 μm band. |
| IM+FM or IM-FM is not accepted. | Check whether the RESET indicator is on. RESET must be executed at least once before the Q7606A/B can be switched over to IM+FM or IM-FM mode. |
| The measurement value varies for each sweep. | Check whether the incident light polarization is stable. If necessary, stabilize it by securing the optical fiber. |
| The IM-MONITOR measurement value varies for each sweep. | After the IM-MONITOR has been set, it takes approximately 20 seconds until the interferometer stabilizes. Start the measurement after the interferometer output data has stabilized. |
| The OVER indicator is lit. | Is the incident light power greater than +10 dBm? Decrease the incident light power. |

| Trouble | Solutions |
|------------------------------------|---|
| The UNDER indicator is lit. | <p>Is the incident light power insufficient? In addition, this symptom occurs when the electric field orientation of the incident light polarization is not aligned with that of the built-in interferometer. Turn the polarization ADJ mode on and perform a RESET. When the UNDER indicator still continues to light up, increase the incident light power.</p> |

6 OPERATING PRINCIPLES

This section explains the principles of the way in which the Q7606A/B can be used to separate and measure the chirpform frequency modulation (FM) and intensity modulation (IM) characteristics.

6.1 Operating Principles

6.1.1 Using the Mach-Zehnder Interferometer as a Lightwave Frequency Discriminator

Figure 6-1 shows the characteristics of the Q7606A/B's built-in Mach-Zehnder interferometer. This figure gives the characteristics of a sine wave, with the lightwave input frequency given to the interferometer along the abscissa and the Mach-Zehnder interferometer's interference output intensity along the ordinate. Therefore, by controlling the optical interferometer so that it matches the lightwave frequency of the incident light, the incident lightwave frequency shift can be observed as the variance of the interferometer outputs. In this situation, however, the optical interferometer output contains both of the FM and IM components of the incident light, and they cannot be separated from each other.

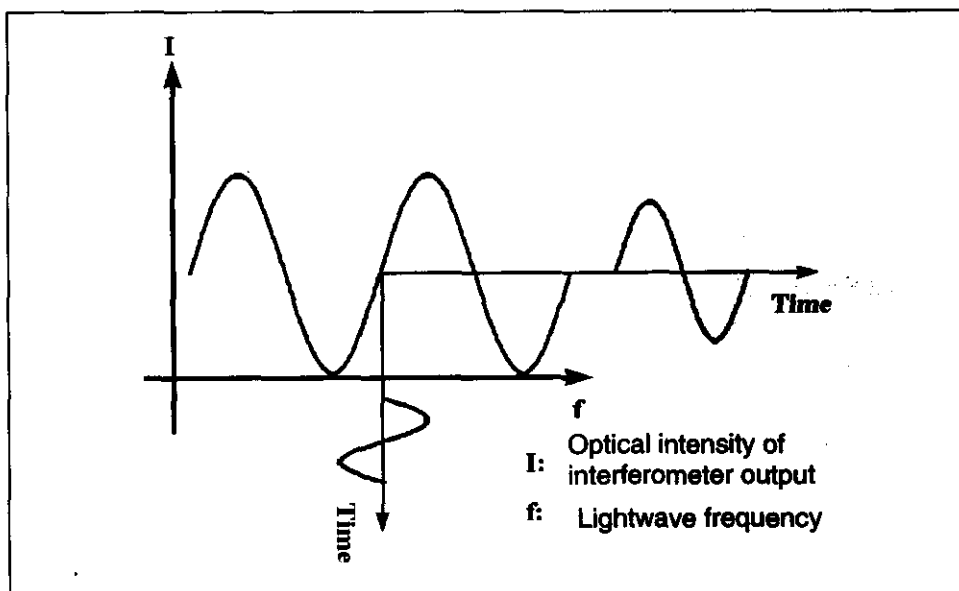

Figure 6-1 Lightwave Frequency-discriminate Characteristics of the Mach-Zehnder Interferometer

6.1 Operating Principles

6.1.2 Separating FM and IM Components

In order to separate the FM and IM components from each other, two different measurement points of the Mach-Zehnder interferometer are used for measurement (see Figure 6-2.) While the interferometer is in state A, it outputs both the IM and FM components in the same phase (IM+FM). In contrast, in state B, the interferometer outputs the IM and FM components in the reverse phase (IM-FM). By calculating the sum and difference using the network analyzer operation functions, the IM and FM data can be separated from each other.

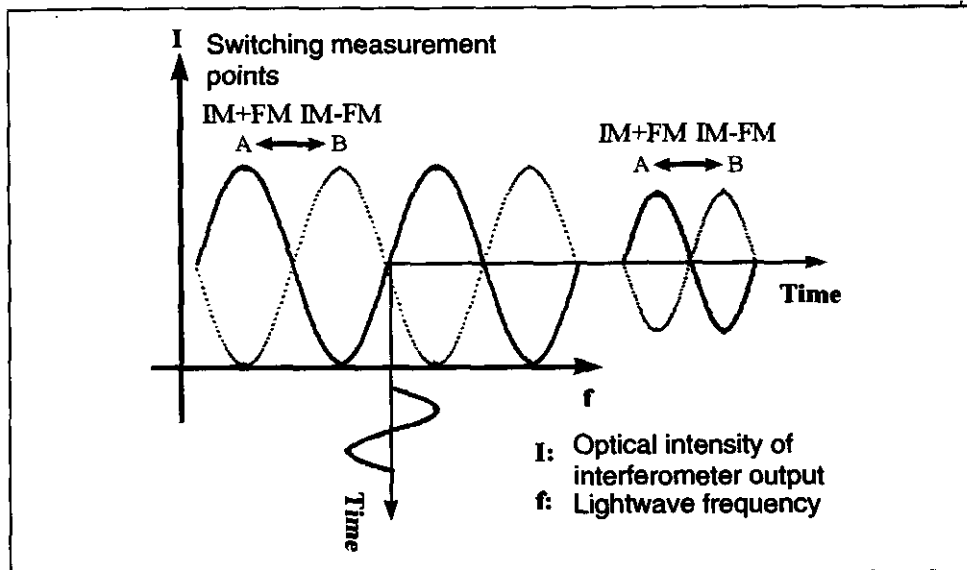

Figure 6-2 Switching Measurement Points of the Mach-Zehnder Interferometer Lightwave Frequency Discriminator

6.1.3 Interferometer Characteristics and Q7606A/B Operations

The Q7606A/B has a pair of interferometers: HIGH-SENS and WIDE-BAND. This section describes the relationships between the interferometer characteristics and Q7606A/B operations.

The characteristics of the Q7606A/B's built-in Mach-Zehnder interferometer are given below.

(1) Interferometer characteristics measured by RESET

The interferometer output maximum and minimum values are obtained by shifting the lightwave frequency discriminated characteristics. The difference between the maximum and minimum values can be read as the interferometer interference amplitude with GPIB commands.

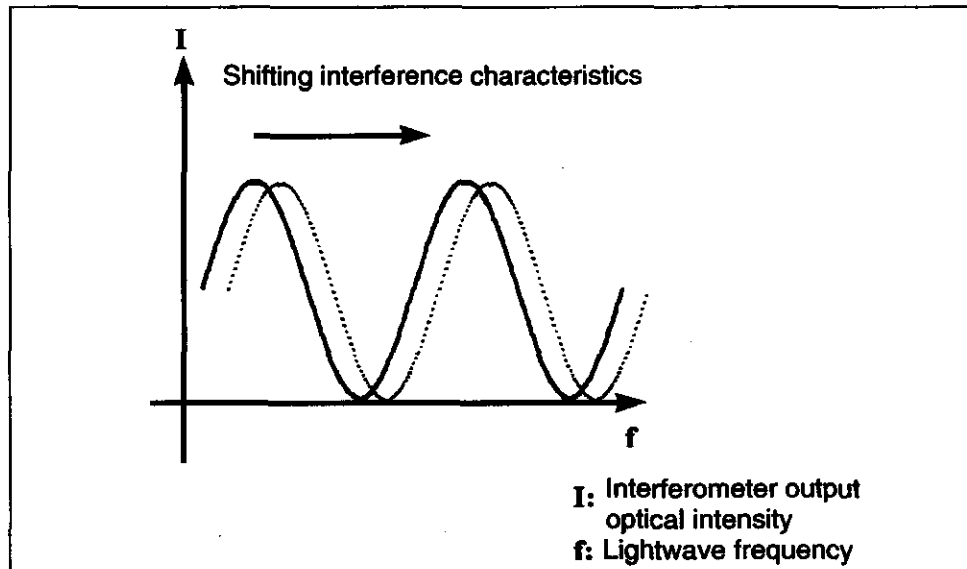

Figure 6-3 Interferometer Characteristics Measured by RESET

6.1 Operating Principles

(2) Interferometer characteristics measured by IM+FM

The lightwave frequency-discriminate characteristics are controlled so that the interferometer output is the sum of the IM and FM characteristics.

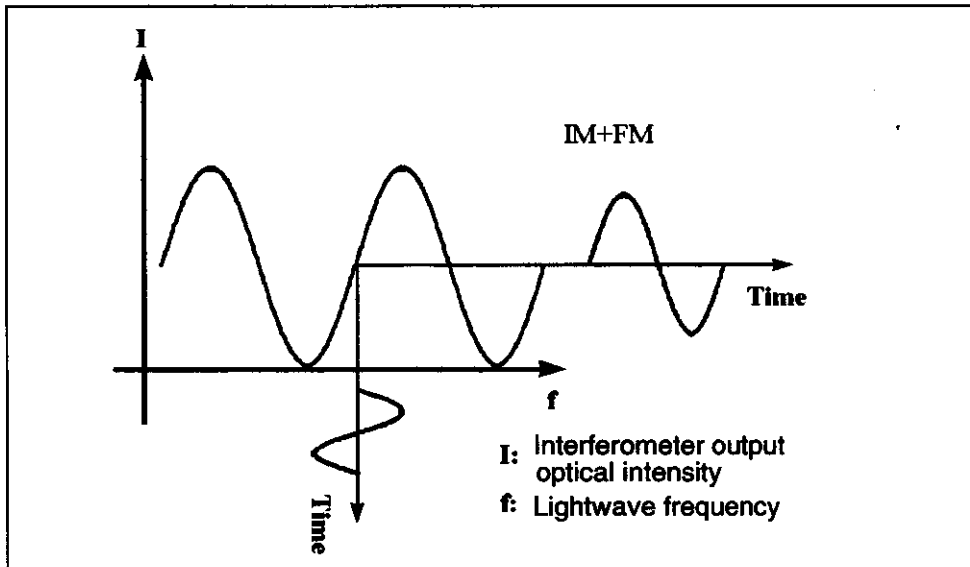

Figure 6-4 Interferometer Characteristics Measured by IM+FM

(3) Interferometer characteristics measured by IM-FM

The lightwave frequency-discriminate characteristics are controlled so that the interferometer output is the difference between the IM and FM characteristics.

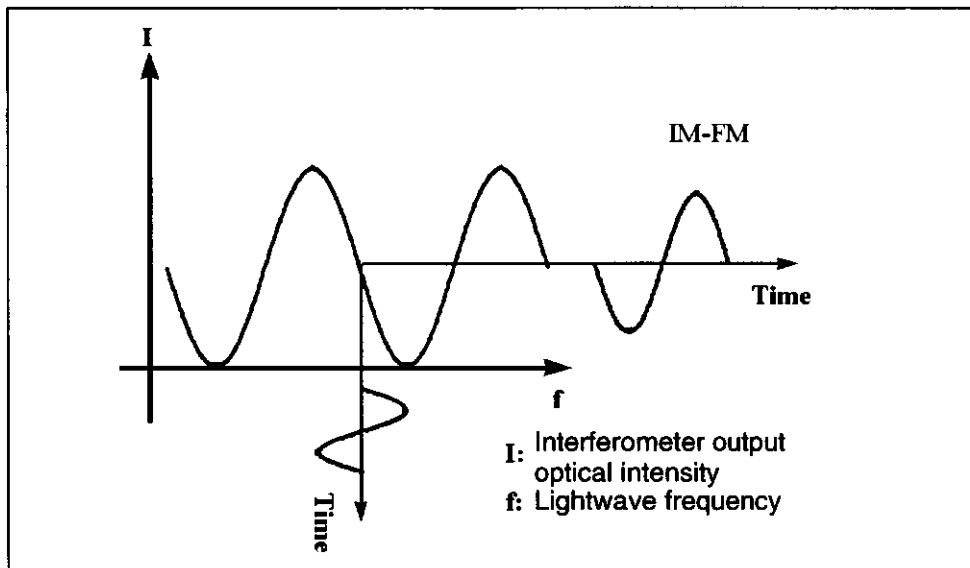

Figure 6-5 Interferometer Characteristics Measured by IM-FM

(4) Interferometer characteristics measured by IM-MONITOR

The lightwave frequency-discriminate characteristics are controlled so that the interferometer output is the IM characteristics only.

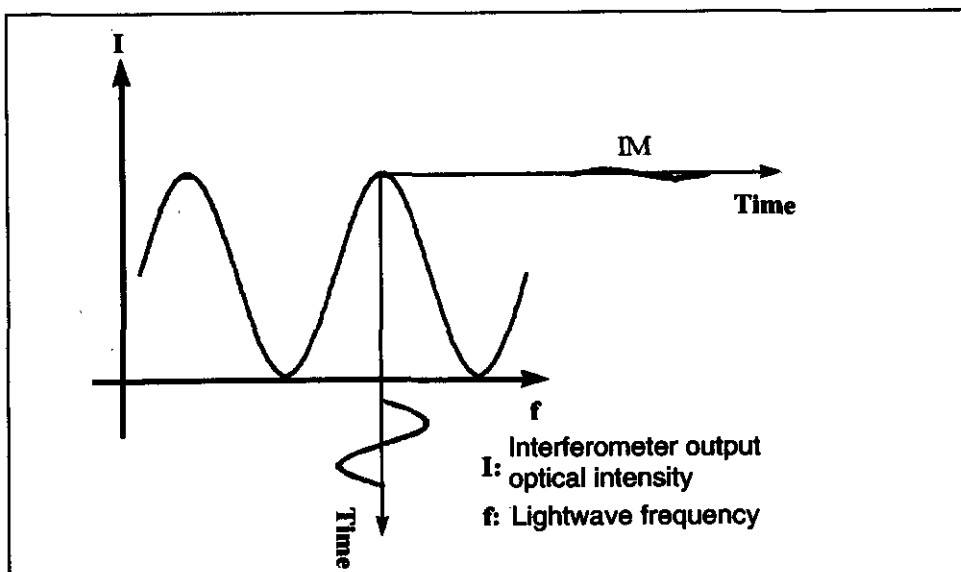

Figure 6-6 Interferometer Characteristics Measured by IM-MONITOR

6.2 Block Diagram

6.2 Block Diagram

Figure 6-7 shows the Q7606A/B block diagram.

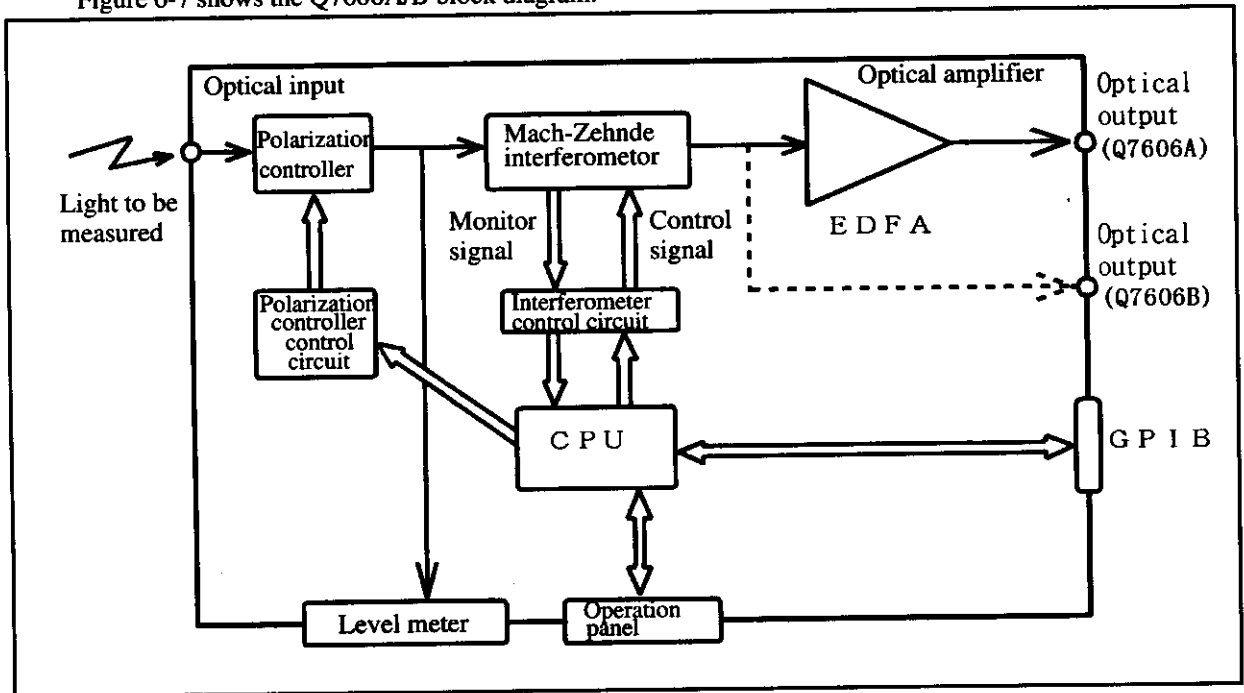

Figure 6-7 Q7606A/B Block Diagram

7 SPECIFICATIONS

7.1 Q7606A/B Major Specifications

Calibrate the Q7606A/Q7606B once a year to take measurements within the specifications listed below.

7.1.1 Measurement Functions

| | |
|---|--|
| Measurement characteristics: | Separated characteristics of chirpform (FM) and IM components |
| Measuring point automatic setting function: | Automatically setting the measuring points for separating the IM and chirpform (FM) components from each other |
| Polarization compensation function: | Built-in automatic optical-fiber type polarization controller |

7.1.2 Input Characteristics

| Item | Specifications (1) | |
|---------------------------------------|---|---|
| | Q7605A | Q7605B |
| Wavelength measurement range | 1530nm to 1580nm | 1510nm to 1590nm |
| Input optical power range | -10dBm to +10dBm | -20dBm to +10dBm |
| Free Spectral Range | 150GHz±15GHz | |
| Demodulation band width (2) | 100Hz to 50GHz | |
| Deviation of demodulation frequency | 65GHz p-p or less | |
| Resolution of demodulation frequency | 20MHz p-p or less (3) | |
| Insertion loss | - | 10dB or less |
| Optical output power | 0dBm or higher (4) | Input cal power (dBm) -10dB or higher (5) |
| Output stage optical amplifier | Built-in optical amplifier with automatic gain adjuster | -(6) |
| Input light polarization compensation | Built-in automatic polarization compensator | |

(1) At 23°C ± 5°C

(2) 130MHz as standard, 1dB down.

(3) Depends on the measurement level resolution of an external sampling oscilloscope and input optical power.

7.1 Q7606A/B Major Specifications

- (4) Output optical power in average. Optical power will be automatically adjusted by the automatic gain adjustment function.
- (5) Depends on the input optical power.
- (6) Generally, when Q7606B is used for chirp measurement, an external optical amplifier capable of gain adjustment is required to obtain optical power conforming with the range of input optical power of an external O/E converter.

7.1.3 Input/Output Specifications

Optical input: FC/PC connector
Demodulation output: FC/PC connector
GPIB: Conforming to IEEE488-1978

7.1.4 General Specifications

Operating conditions: Temperature 0°C to +40°C
Relative humidity 85% or less
Storage conditions: Temperature -20°C to +60°C
Relative humidity 90% or less
Power supply: 100VAC to 120VAC or 220VAC to 240VAC (automatic switching),
50/60Hz, 85VA or less
Outside dimensions: Approx. 424 (W) x 132 (H) x 500 (D) mm
Mass: 15kg or less

APPENDIX

A.1 Glossary

Automatic power control (APC)

The mechanism for supplying power so that the optical output is kept constant. The optical output from a laser diode driven by constant current falls or stops when the temperature rises, and increases when the temperature lowers. The optical output may exceed the maximum rating when the temperature is too low. In order to protect the laser diode and stabilize the optical output, this circuit receives the monitor light of laser diode through the photo diode and then make it feed back to the drive circuit for laser diode.

Avalanche photo diode

A light-receiving element frequently used for optical-fiber communications. It uses an avalanche effect: a high reverse bias-voltage (100V to 200V) given to a semiconductor pn junction first moves a few carriers, causing successive carriers to be generated and making the current increase at an accelerated rate.

Baseband transmission characteristics

When an optical pulse is input to an optical fiber, the output pulse at the other end diverges, and this phenomenon is called divergence. That is, the transmission loss increases in the time domain. When converted to the frequency domain, it shows an increase in the transmission loss in the high-frequency band. The transmission characteristics in this frequency domain are called the baseband transmission characteristics, and these are important for optical-fiber performance.

Beam divergence angle

The angle from the optical axis that halves the radiant intensity from its maximum. For a laser diode, the horizontal direction to the junction is indicated by $\theta //$ and the perpendicular direction is indicated by $\theta \perp$. ($\theta \perp > \theta //$)

Chopped light

A light with its intensity modulated by a square wave. Its optical output goes on and off repeatedly at a certain cycle.

Cladding

A part of the optical-fiber structure. An optical fiber consists of the core axis and the cladding surrounding the core. The fibers are generally made of quartz glass or plastics. The cladding has a refractive index approximately 1% less than that of the core, which helps contain the light flux within the core.

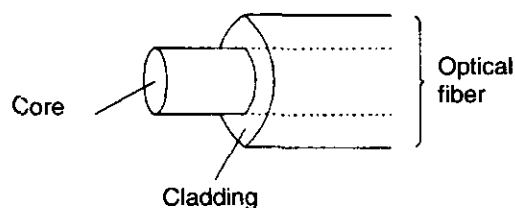

A.1 Glossary

Coated fiber

One type of optical fiber, the core and cladding of which are covered by primary coating (silicon resin) and secondary coating (protective nylon layer).

Coherence

1. The existence of a timing correlation between the phases of two or more waves.
2. When the wavelengths, phases, and wave faces of light are exactly the same, the light is said to be coherent. There are two types of coherence: temporal and spatial. Temporal coherence is wavelength uniformity and phase continuity. Spatial coherence is the convergence of light into one point by a lens. As represented by laser light, light that has a constant wavelength and stable phase relationships is called coherent.

Coherent

Light is one type of electromagnetic wave, and has an extremely short wavelength. However, visible light has characteristics significantly different from those of the electromagnetic waves used for radio and TV programs. That is, while the frequencies, phases, and wave faces of electromagnetic waves are exactly the same, those of visible light vary. Visible light is therefore regarded as a certain type of noise. Light that has exactly the same frequencies, phases, and wave faces is said to be coherent. The light emitted from a laser diode used for optical communications has very high coherence, although it is not perfect.

Continuous-wave (CW) light

A non-modulated light with constant intensity. Also known as a DC light.

Core

Part of the optical-fiber structure. The core is the central axis, surrounded by cladding. A light flux propagates through the core. It is made of quartz glass and has a refractive index that is larger than that of the cladding by 1%. There are two types of optical fiber: multi mode fibers, with a core thickness of 50 to 100 $\mu\text{m}\phi$, and single-mode fibers, with a core thickness of approximately 10 $\mu\text{m}\phi$. Optical fibers can also be classified into the graded index (GI) and step index (SI) types, depending on the refractive index distribution of the core.

Core and cladding

The core is the central axis of the optical fiber, and cladding covers the core. Because the cladding has a lower refractive index than that of the core, the incident light propagates through the core, within which it is contained, repeating total reflection at the boundary face between the core and cladding. Generally, the core and cladding diameters are indicated as 50/125 μm , which means a core diameter of 50 μm and a cladding diameter of 125 μm .

Dark current

Current output from a light-receiving element when no incident light is given to it.

Direct modulation

The method that use a modulating signal as drive current to turn the light source on. The method of using a lightwave modulator is called external modulation.

Directivity

The property of having a large optical output or responsivity in a specific direction.

Distributed feedback laser (DFB-LD)

A type of laser that has a waveguide with a cyclic structure, to form a resonator that has a selective wavelength.

Double heterojunction

A heterojunction means a junction by crystals with different atomic structures. The double heterojunction in laser diodes places a cladding layer with a large energy gap on both sides of the active layer. It is used to raise the minority carrier density and to form an optical waveguide.

Emission peak wavelength

The wavelength of a light-emitting element that produces the maximal energy density of the emission spectrum.

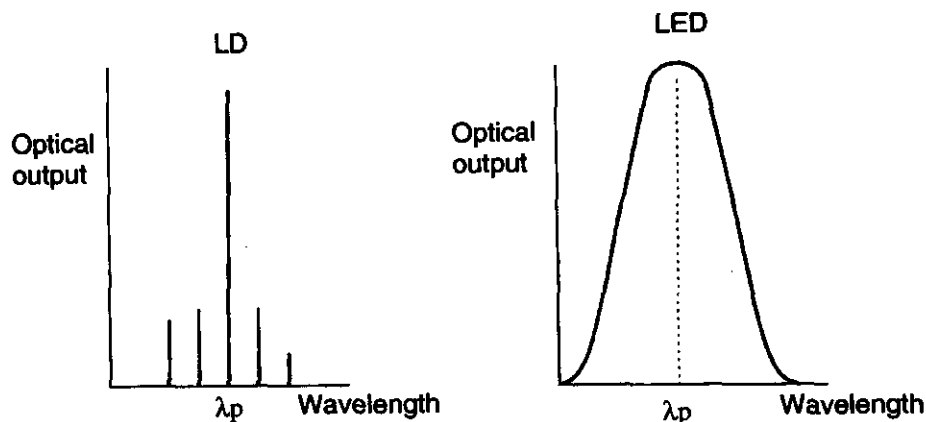

Excess noise factor

Factor of shot noise multiplication occurring in an avalanche photodiode. It is defined as $F = Mx$.

Because of the fluctuation in the multiplication process, shot noise current iN increases as

$$\langle iN^2 \rangle = 2qIM^{2+x} B.$$

M : Multiplication factor

B : Signal bandwidth

x : Excess noise factor

q : Electron charge

I : Average current flowing in the avalanche area

FM

Frequency modulation

A.1 Glossary

Free spectral range (FSR)

Peak-to-peak interval of the output from the Q7605A/B's built-in Mach-Zehnder interferometer. The narrower the FSR is, the more accurately FM measurement is carried out, but the frequency characteristics deteriorate.

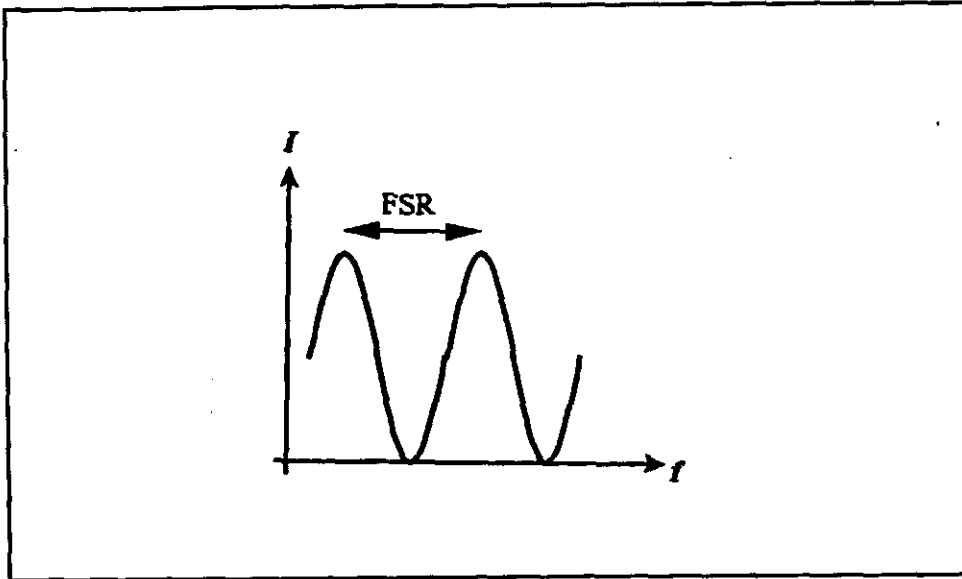

Figure A-1 Interference Characteristics and FSR of the Mach-Zehnder Interferometer

Fundamental mode

0-dimensional electromagnetic field distribution. Also known as single lateral mode.

Graded index fiber

One type of multi mode fiber, the core refractive indices of which are distributed in a parabolic form. This means that the light passing through the center of the core goes more slowly, and the light passing through the periphery goes faster, making the propagation speed constant regardless of the light path. In addition, the timing distribution of output pulses can be made extremely small (*little mode dispersion*). This means that the transmission band (hundreds of MHz · km) is much wider than that of the step index fiber.

IM

Intensity modulation

Infrared rays

Light with wavelengths longer than those of visible light.

Wavelength 0.78 to 3 μ m: Near-infrared light

3 to 30 μ m: Mid-infrared light

30 μ m to 1mm: Far-infrared light

1mm or more: Microwave

Laser

There are several types of laser: solid-state, gas, liquid, etc. Solid-state lasers are used as the light source for optical-fiber communications, because they are smaller than other types of laser and allow direct modulation. Compared to LEDs, lasers have better coherence and faster responses, and they are therefore important elements as a light source. A solid-state laser is sometimes abbreviated LD, standing for laser diode.

Laser diode

One type of semiconductor light-emitting element. The word laser stands for Light Amplification by Stimulated Emission of Radiation. A laser is an oscillator that emits light using this principle. A laser diode gives a high optical output. Laser diodes have advantages such as high optical output, the possibility of fast direct modulation, good optical-fiber coupling efficiency, etc., but they have a problem in the stability of the light emission. This is why LEDs have mainly been used. Recently, since this problem is now being solved, laser diodes are being used more than before for long-distance, fast communications.

Leak light

When an optical fiber is bent or pressed, the light propagation path in the core is distorted, causing the propagating light to leak out of the optical fiber. This is called leak light.

Light-emitting diode (LED)

One type of light-emitting element. As in the case of a laser diode, it uses the light emitted when the carriers injected into the semiconductor pn junction face recombine. In a laser diode, light is generated by induced emission, whereas in an LED it is generated by spontaneous emission. An LED has advantages such as long life, stability, low cost, and good linearity. However, because an LED produces only a small output to send to the fiber and is not suitable for fast modulation, it is advantageous for short-distance, small-capacity communications or analog-type communications.

Light sensor

For optical-fiber communications, a photodiode (PD) using the photovoltaic effect or photoconductive effect is used. There are two types of PDs: pn and pin. Those applying the avalanche effect by giving reverse bias voltage are called avalanche photodiodes (APD). These photoreceivers are mainly used for measurement devices. In addition, thermopiles employing the thermo effect have constant sensitivity regardless of the wavelength, and are used as detectors in reference optical power meters.

Longitudinal mode

A state which emission spectrum, that a half height width is extremely small, exist discontinuously. An individual emission spectrum is also called a longitudinal mode. The wavelength difference with the adjacent mode is called a longitudinal mode interval. When there is only one mode, it is called a single longitudinal mode.

Long wavelength region

Among the optical wavelengths used for optical-fiber communications, this is the region of 1.0 to 1.5 μ m. This region is used for long-distance communications, because it produces little transmission loss with optical fibers.

A.1 Glossary

Luminous flux

$$F = K_m \int_{380}^{780} V(\lambda) d\lambda$$

Unit: lm (lumen)

K_m : Maximum visibility 680lm/W

$V(\lambda)$: Standard spectral luminous efficiency

Value determined by International Commission on Illumination (CIE)

1.0004 when $\lambda = 555\text{nm}$ (yellow-green)

Luminous intensity

$$i = \frac{dF}{dw}$$

Unit: Cd (candela)

F: Luminous flux

w: Solid angle

Radiant intensity is the value indicated by an energy unit.

Mach-Zehnder interferometer

A type of interferometer which the incident light is split into two routes, and a delay is given to one route but not to the other. The two waves are then composed again to cause interference.

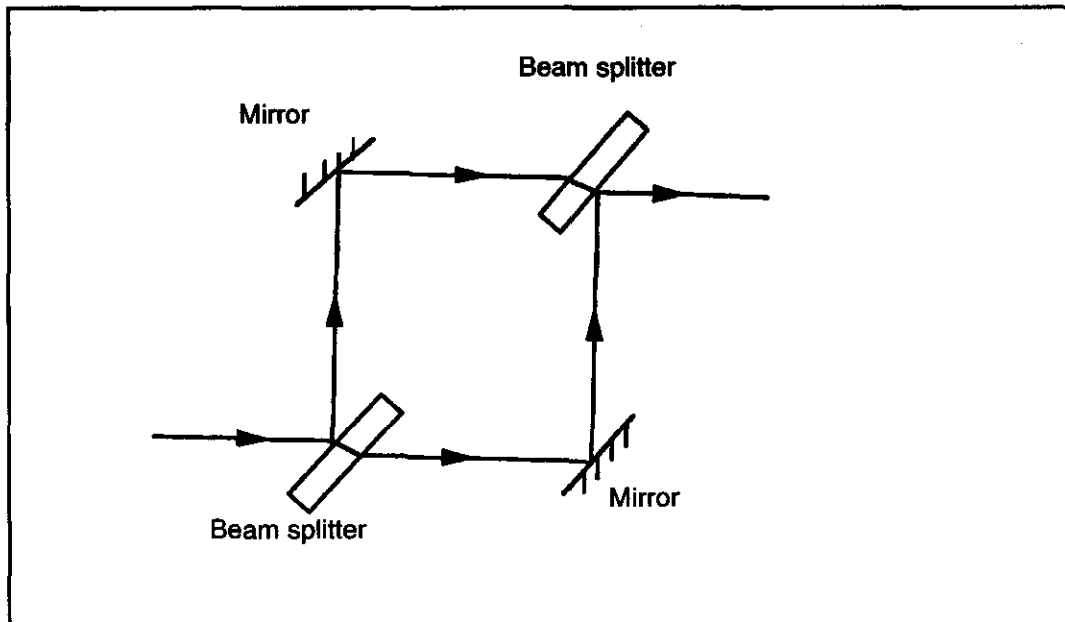

Figure A-2 Typical Mach-Zehnder Interferometer Configuration

Monitor current

Monitor diode output generated when the light emitted from the rear of the laser diode chip is received by the monitor diode.

Monitor output

A light emitted from the rear of the laser diode chip.

Multi mode fiber

An optical fiber that has more than one propagation mode, and many of these modes (which can be assumed to be light with various angles to the optical fiber's central axis) propagate through the core at the same time. Multi mode fibers can be classified into step, graded, and other types, depending on the refractive indices of the core. They are advantageous in that the core diameter is comparatively large (50 to 100 μm), and connections are easier than with single mode fibers. On the other hand, the transmission band area is somewhat narrow (mode divergence), because many modes propagate at different speeds through the optical fiber.

Numerical aperture

The degree of extension of light at the end of an optical fiber, which has a cylindrical core having a refractive index of n_1 and which is surrounded by clad having a refractive index of n_2 ($n_1 > n_2$), due to a similarity in the lens system. Of the light falling on a plane, which includes the axis of the core of the optical fiber and which crosses the axis (the meridian light), if some light, which attains critical angle with respect to the axis, crosses the axis of the core outside the optical fiber at angle θ , the NA of the optical fiber can be expressed by the equation given below.

$$\text{NA} = n \sin \theta = \sqrt{n_1^2 - n_2^2}$$

n: Refractive index of the media in which the optical fiber is placed

Optical fiber

An optical waveguide in which the outer refractive index is made less than the inner one to give the fiber such characteristics that enable the light to propagate inside the fiber, even when the fiber is bent.

A fiber with a diameter of approximately 0.12mm ϕ consisting of two types of quartz glass (core and cladding) with different refractive indices. It shows superior characteristics such as wide band, small loss, and noninduction.

Optical fiber connector

A detachable connector for connecting optical fibers to one other, or an optical fiber to a device. Usually simple matching is used for connection, that is, optical-fiber faces are connected directly to each other by using connectors with their cores well aligned. Compared with electrical connectors, an optical fiber connector has some disadvantages: high mechanical precision is necessary, a connection loss of approximately 0.5 to 1dB occurs, and careful treatment is required to prevent dust.

Optical rotating power

A phenomenon in which the plane of polarization rotates when a linear polarized light passes through a substance.

Pigtail fiber

A fiber with its one or both ends are open.

Polarizer

An element that converts natural light into a linear polarized wave.

Quantum efficiency

- Light-emitting element (light-emitting diode, laser diode)

The ratio of the number of photons generated inside an element to the number of carriers generated (internal quantum efficiency); or the ratio of the number of photons emitted outside to the number of generated carriers (external quantum efficiency).

The quantum efficiency can be expressed as follows:

$$\eta = \frac{q\lambda}{hc} \cdot \frac{p}{I} = \frac{\lambda}{1.24} \cdot \frac{p}{I}$$

h: Planck's constant

c: Light speed in vacuum

q: Charge of electron

λ : Wavelength (μ m)

P: Optical output

I: Current

In addition, a differential quantum efficiency is also used for a laser diode.

- Light receiving element (PIN photodiode APD)

The ratio of the number of generated carriers to the number of input photons. The quantum efficiency η' is expressed as follows. This is the reverse of that of a light-emitting diode

$$\eta' = \frac{hc}{q\lambda} \cdot \frac{I}{P} = \frac{1.24}{\lambda} \cdot \frac{I}{P}$$

The quantum efficiency of an avalanche photodiode is calculated assuming that the multiplication factor is 1.

Radiant flux

Optical energy emitted and propagated in a unit of time.

Responsivity

Current that can be generated when a unit radiant flux is input to a light-receiving element.

$$R = \frac{I}{P} = 0.806 \times \eta \times \lambda \times M \quad [A/W]$$

R : Responsivity

η : Quantum efficiency

λ : Wavelength

M: Multiplication factor

ROM

Stands for Read-Only Memory.

Short wavelength region

Optical-fiber communications use light with a wavelength of approximately 0.8 to 1.5 μm , or the near-infrared region. Within this region, the region around 0.8 μm is called the short-wavelength region. This region was developed during an earlier stage in the field of optical-fiber communications, and produced the largest number of results for production systems. Recently, the long wavelength region exceeding 1 μm has been under development.

Single-mode fiber

When the core diameter is reduced to approximately 10 μm , the result is an optical fiber with only one propagation mode. This is called a single-mode fiber. This fiber is advantageous in that, unlike the multi mode fiber which causes mode distribution, it has a very wide range (a few GHz).

Specific rotating power

A value indicating the magnitude of the optical rotary power of material.

Speckle effect

A noise generated when a coherent light is dispersed in an optical fiber, causing interference under irregular phase relationships.

Spectral width/Full width at half maximum/ $\Delta\lambda$

An interval between two wavelengths of a light emitting element, in which the emission spectrum energy is half the maximal value.

Spectrum

An ordinary light consists of sine wave components. An array of such components arranged along the wavelength axis is called a spectrum.

A white light source has a flat spectrum, and an LD has one concentrated in a narrow area.

Splicing

Permanent connection of an optical fiber, necessary for optical-fiber cabling operations. Although there are various splicing methods, the method generally used is fusion splicing, in which glass is melted by arc discharge. This method allows stable connections with the least connection loss.

Threshold current

Minimum current that allows laser emission. Since the boundary area between the spontaneous and laser emissions is not rigid, it is sometimes represented by the crossing point of the line prolonged from the current

A.1 Glossary

optical output characteristics curve for laser oscillation and the current value for optical output zero.

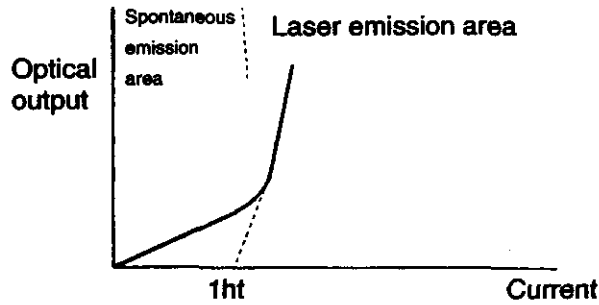

Ultraviolet rays

Light with a shorter wavelength than visible light. The wavelengths range from 300 to 380nm.

Visible light

Light that can be seen by the human eye. The wavelength range is 380 to 780nm.

Wavelength division multiplying

A communication method in which two or more types of signals are simultaneously transmitted through one optical fiber. In the transmitter, light-emitting and laser diodes of various wavelengths are used. This method allows one-way or two-way communications.

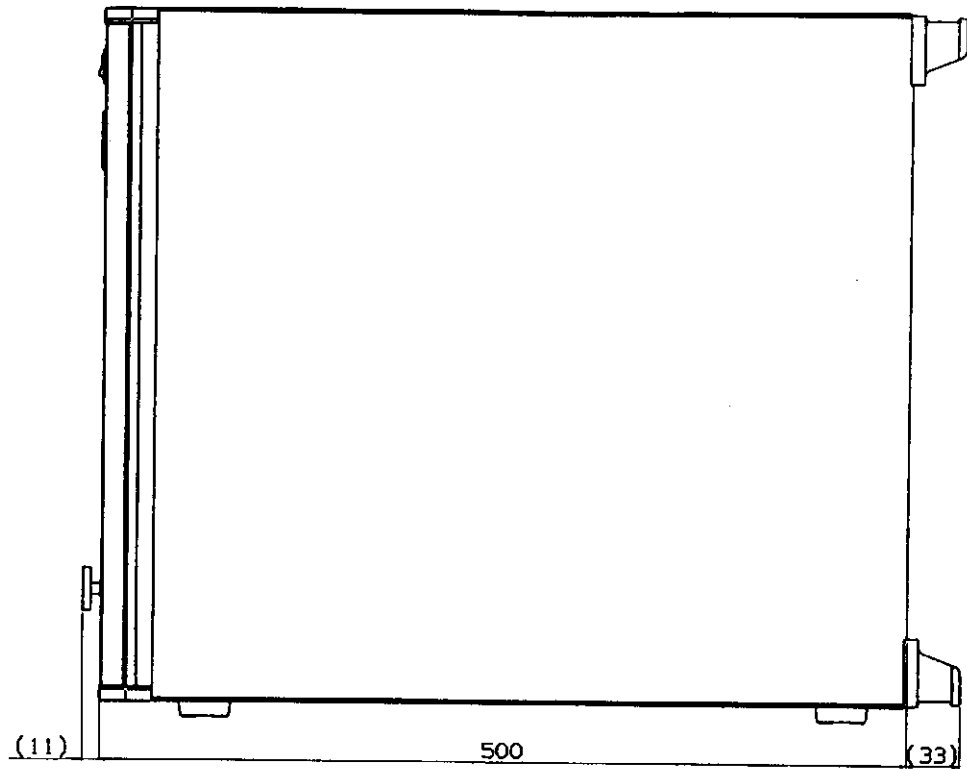
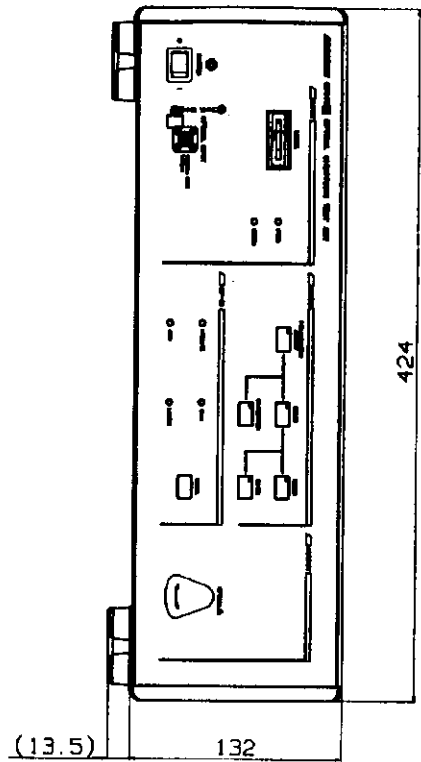

Unit : mm

CAUTION

This drawing shows external dimensions of this instrument.

The difference in products and options used can cause a change in the appearance of the instrument.

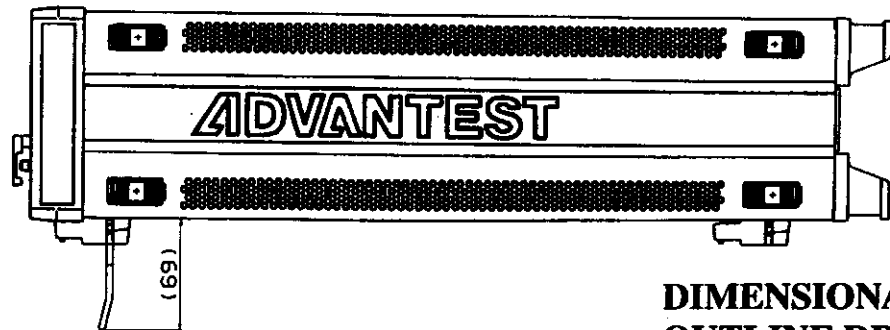

**DIMENSIONAL
OUTLINE DRAWING**

ALPHABETICAL INDEX

| | | | |
|---|-----------|--|----------|
| [A] | | | |
| Acceptor handshake function | 4-4 | Demodulation output | 7-2 |
| Accessories | 1-3 | Deviation of demodulation frequency..... | 7-1 |
| Address specification | 4-3 | Device clear function | 4-4 |
| Address switch | 4-6 | Device trigger function | 4-4 |
| AH1 | 4-4 | DFB-LD | A-3 |
| AJn | 4-9, 4-10 | DFT-AA2R5A-1 | 1-7 |
| APC | A-1 | digital sampling oscilloscope | 1-2 |
| ATN | 4-2 | Direct modulation | A-2 |
| Attention | 4-2 | Directivity | A-3 |
| Automatic power control | A-1 | Distributed feedback laser | A-3 |
| Avalanche photo diode | A-1 | DLn | 4-9 |
| | | <i>Double heterojunction</i> | A-3 |
| | | Driver specifications | 4-3 |
| | | DT1 | 4-4 |
| [B] | | | |
| Baseband transmission characteristics | A-1 | | |
| Beam divergence angle | A-1 | [E] | |
| block delimiter | 4-12 | E2 | 4-4 |
| buzzer | 4-12 | Emission peak wavelength | A-3 |
| BZn | 4-9, 4-10 | End of Identify | 4-2 |
| | | Environment Conditions | 1-5 |
| | | EOI | 4-2 |
| | | Excess noise factor | A-3 |
| [C] | | | |
| C | 4-9 | | |
| C0 | 4-4 | [F] | |
| Cable | 4-3 | FM | A-3 |
| Chopped light | A-1 | Front Panel | 2-1 |
| Cladding | A-1 | Free Spectral Range | 7-1 |
| Cleaning | 1-8 | Fundamental mode | A-4 |
| Cleaning Connectors | 1-8 | Fuse | 1-7 |
| Coated fiber | A-2 | | |
| Code used | 4-3 | [G] | |
| Coherence | A-2 | GPIB | 4-1, 7-2 |
| Coherent | A-2 | GPIB address switch | 2-3 |
| Configuration | 1-2 | GPIB Commands | 4-9 |
| Connecting Component Devices | 4-5 | GPIB connector | 2-3 |
| Connector | 4-3 | GPIB Talker Format | 4-8 |
| Continuous-wave (CW) light | A-2 | Ground terminal | 2-3 |
| control lines | 4-1 | | |
| Core | A-2 | [H] | |
| CS | 4-9, 4-11 | handshake lines | 4-1 |
| | | | |
| [D] | | | |
| Dark current | A-2 | [I] | |
| data lines | 4-1 | IEEE 488-1978 | 4-3 |
| Data Valid | 4-2 | IFC | 4-2 |
| DAV | 4-2 | IM+FM | 6-4 |
| DC1 | 4-4 | IM+FM key | 2-2 |
| Demodulation band width | 7-1 | | 2-2 |
| Demodulation frequency | 7-1 | | |

Alphabetical Index

| | |
|---|-----|
| IM-FM | 6-4 |
| IM-MONITOR | 6-5 |
| IM-MONITOR key | 2-2 |
| Input light polarization compensation | 7-1 |
| Input optical power range | 7-1 |
| Input/Output Specifications | 7-2 |
| Insertion loss | 7-1 |
| Interface Clear | 4-2 |
| Interface Functions | 4-4 |
| Interferometer | 6-3 |
| Interferometer Characteristics | 6-3 |

[K]

| | |
|-----------|-----|
| key | 2-2 |
|-----------|-----|

[L]

| | |
|-------------------------|----------|
| L4 | 4-4 |
| Level meter | 2-1 |
| LISTEN indicator | 2-2, 4-6 |
| listener function | 4-4 |
| listener reset | 4-4 |
| LOCAL key | 2-2, 4-5 |
| Logic level | 4-3 |

[M]

| | |
|---|-----------|
| MDn | 4-9, 4-10 |
| Measurement characteristics | 7-1 |
| Measuring point automatic setting function .. | 7-1 |

[N]

| | |
|--------------------------|-----|
| NDAC | 4-2 |
| Not Data Accepted | 4-2 |
| Not Ready For Data | 4-2 |
| NRFD | 4-2 |

[O]

| | |
|-------------------------------------|----------|
| O/E converter | 1-2 |
| Operating conditions | 7-2 |
| OPERATING PRINCIPLES | 6-1 |
| operation mode | 4-12 |
| Optical input | 7-2 |
| OPTICAL INPUT connector | 2-1 |
| Optical output power..... | 7-1 |
| OUTPUT SELECT | 4-12 |
| Output stage optical amplifier..... | 7-1 |
| Outside dimensions | 7-2 |
| OVERVIEW | 1-1, 3-1 |

[P]

| | |
|--|-----|
| PANEL DESCRIPTIONS | 2-1 |
| personal computer | 1-2 |
| Polarization compensation function | 7-1 |
| | 2-1 |
| Power Cable | 1-6 |
| Power connector | 2-3 |
| POWER indicator | 2-1 |
| Power supply | 7-2 |
| PP0 | 4-4 |
| Product Overview | 1-1 |

[R]

| | |
|---|----------|
| Reading the Status Data Set | 4-12 |
| Rear Panel | 2-3 |
| Receiver specifications | 4-3 |
| receptacle | 1-8 |
| Remote Enable | 4-2 |
| Remote function | 4-4 |
| REMOTE indicator | 2-2, 4-5 |
| REN | 4-2 |
| RESET | 6-3 |
| RESET key | 2-1 |
| Resolution of demodulation frequency..... | 7-1 |
| RL1 | 4-4 |

[S]

| | |
|---------------------------------|-----------|
| Sample Programs | 4-13 |
| Service request function | 4-4 |
| SH1 | 4-4 |
| SLn | 4-9, 4-10 |
| Sn | 4-9, 4-10 |
| Source handshake function | 4-4 |
| Specifications | 7-1 |
| SR1 | 4-4 |
| SRQ | 4-2 |
| SRQ indicator | 2-2, 4-5 |
| Standard accessories list | 1-3 |
| Standard bus cables | 4-5 |
| Status byte | 4-7 |
| Storage | 1-8 |
| Storage conditions | 7-2 |
| string delimiter | 4-12 |
| switch | 2-1 |

[T]

| | |
|-----------------------|----------|
| T6 | 4-4 |
| TALK indicator | 2-2, 4-6 |
| talker function | 4-4 |
| talker reset | 4-4 |

| | |
|------------------------|-----|
| Transportation | 1-8 |
| Tri-state output | 4-4 |
| TROUBLESHOOTING | 5-1 |

[W]

| | |
|------------------------------------|-----|
| Wavelength measurement range | 7-1 |
| WIDE-BAND connector | 2-2 |

[Others]

| | |
|-----------------|-----|
| 408JE-101 | 4-5 |
| 408JE-102 | 4-5 |
| 408JE-104 | 4-5 |
| 408JE-1P5 | 4-5 |

WARRANTY

ADVANTEST product is warranted against defects in material and workmanship for a period of one year from the date of delivery to original buyer.

LIMITATION OF WARRANTY

The foregoing warranty shall not apply to defects resulting from improper or inadequate maintenance by buyer, unauthorized modification or misuse, accident or abnormal conditions of operations.

No other warranty is expressed or implied. ADVANTEST specifically disclaims the implied warranties of merchantability and fitness for a particular purpose.

ADVANTEST shall not be liable for any special incidental or consequential damages, whether in contract, tort or otherwise.

Any and all warranties are revoked if the product is removed from the country in which it was originally purchased.

SERVICE

During the warranty period, ADVANTEST will, at its option, either repair or replace products which prove to be defective.

When trouble occurs, buyer should contact his local supplier or ADVANTEST giving full details of the problem and the model name and serial number.

For the products returned to ADVANTEST for warranty service, buyer shall prepay shipping and transportation charges to ADVANTEST and ADVANTEST shall pay shipping and transportation charges to return the product to buyer. However, buyer shall pay all charges, duties, and taxes incurred in his country for products returned from ADVANTEST.

CLAIM FOR DAMAGE IN SHIPMENT TO ORIGINAL BUYER

The product should be thoroughly inspected immediately upon original delivery to buyer. All material in the container should be checked against the enclosed packing list or the instruction manual alternatively. ADVANTEST will not be responsible for shortage unless notified immediately.

If the product is damaged in any way, a claim should be filed by the buyer with carrier immediately. (To obtain a quotation to repair shipment damage, contact ADVANTEST or the local supplier.) Final claim and negotiations with the carrier must be completed by buyer.

SALES & SUPPORT OFFICES

Advantest(Singapore)Pte.Ltd.

438A Alexandra Road

#08-03/06 Alexandra Technopark Singapore 119967

Phone : 65-274-3100 Facsimile : 65-274-4055

ROHDE & SCHWARZ Engineering and Sales GmbH

Mühlendorfstr. 15 (P.O.B. 80 1429, D-81614 München)

D-81671 München, Germany

Phone : 49-89-4129-13711 Facsimile : 49-89-4129-13723

TEKTRONIX INC.

P.O. Box 500, M/S 39-520, Beaverton, Oregon 97077-0001

or

Howard Vollum Industrial Park, M/S 58-743, Beaverton, OR, 97077, U.S.A.

Inside the U.S. 1-800-426-2200

Outside the U.S. 1-503-627-1933

— Technology Support on the Leading Edge —

ADVANTEST®

ADVANTEST CORPORATION

Shinjuku NS Building 4-1 Nishi-Shinjuku 2-chome Shinjuku-ku Tokyo 163-0880 Japan