

PULSE RIDER

Application Note

Pulse Rider Model 765 Series Pulse Generator for Radar Applications



Primary Pulse Radar

A primary radar generates a signal that illuminates the target and it receives its echo. It is possible to distinguish between different types of radars depending on the modulation (analog or digital) and on the discontinuities of the generated signal.

The simplest radar is the pulse radar, it doesn't use any type of modulation, but it operates generating a signal for a short time and receiving the echo response produced by the target that reflects the signal.

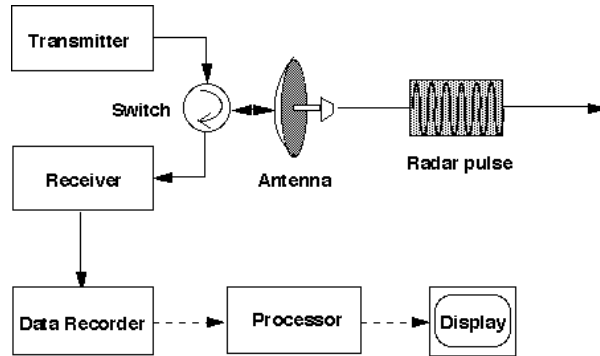
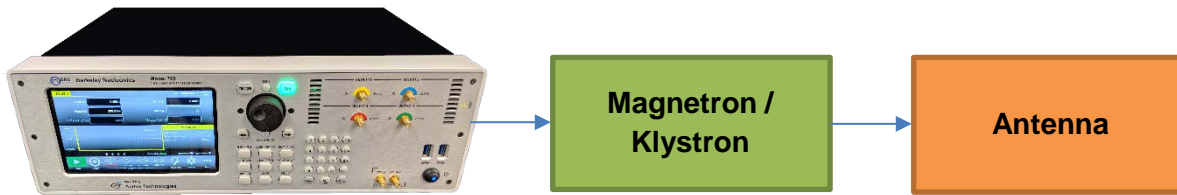

Figure 1 Primary Pulse Radar basic diagram

In this way, it determines the distance from object calculating the time of flight between the sent signal and the received echo. This architecture is limited by the trade-off between the **maximum range** and the **resolution**: so a larger pulse increases the average transmitted power and then the maximum range, but reduce the resolution. For this reason, this type of radar finds application in long-range control, principally in air traffic control and weather observation (especially precipitation).



Model 765

Figure 2 Example of magnetron / klystron driving using Pulse Rider series

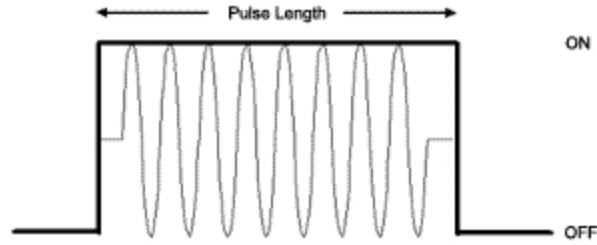

Figure 2 Radar pulse

During the development of a system, it is useful to use a pulse generator that supplies the pulses to the RF modulating chain to test the receiver behaviour varying the pulse duration.

The Model 765 Series pulse generators powered by Active Technologies allow to create pulses with different pulse width, repetition rate and amplitude easily using the graphical interface and the touch screen display.

Following this solution, it is possible to save the time to develop the pulse system and concentrate the efforts on the radar design and test goals.

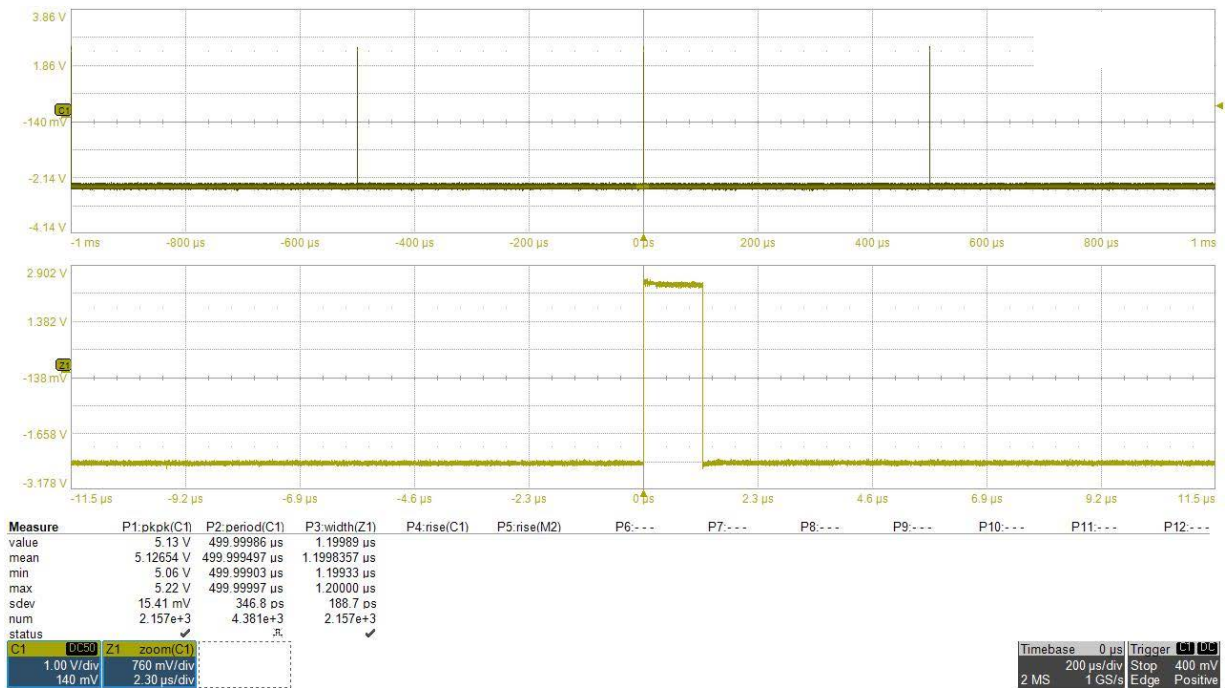

Figure 3 Radar pulse: Pulse Repetition Interval (PRI) = 500 μs, width 1.2 μs

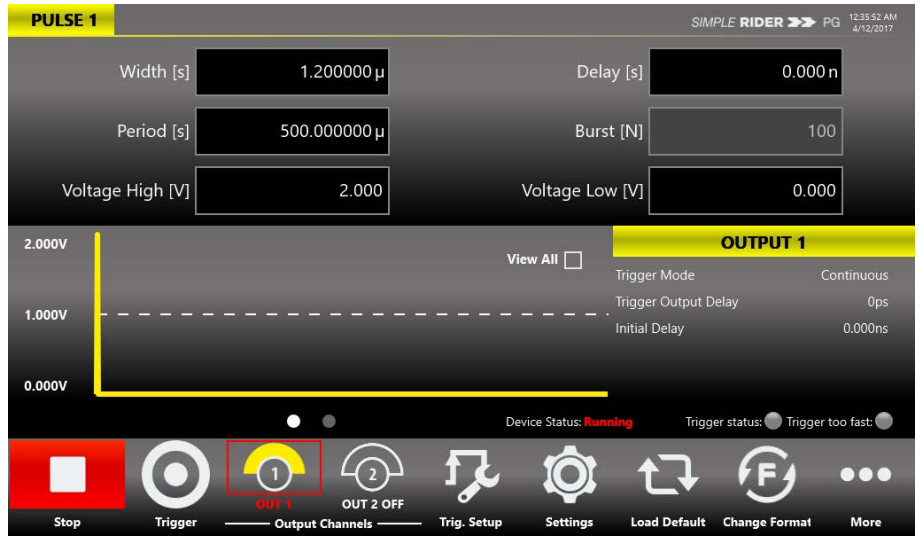

Figure 3 Pulse Rider interface in continuous generation

Secondary Radar

A secondary radar is a particular type of radar used for air traffic control that works in conjunction with the aircraft transponder. It interrogates the transponder using a pulse code and wait for the response; depending on the transmitted code, it can request the identification number, the altitude, etc.

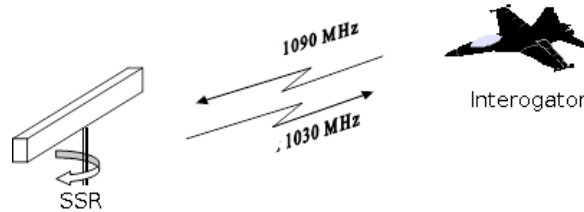

Figure 4 Secondary Radar basic diagram

The interrogation base band code is very simple, it is composed by 3 pulses called P1, P2 and P3 with a fixed duration of 800 ns.

The first pulse (P1) and the last one (P3) are transmitted by a directive antenna defining the code through the distance between them.

The second pulse (P2) is transmitted in omnidirectional way with a delay of 2 μs from the first one; this particular pulse is necessary because the secondary lobes emitted by the directive antenna could hit other transponders causing a wrong response and interference. The transponder measures the received power during the pulse P1 and during the pulse P2 and it distinguishes whether it is reached by the main antenna lobe or by a secondary one, and in the first case it sends the response.

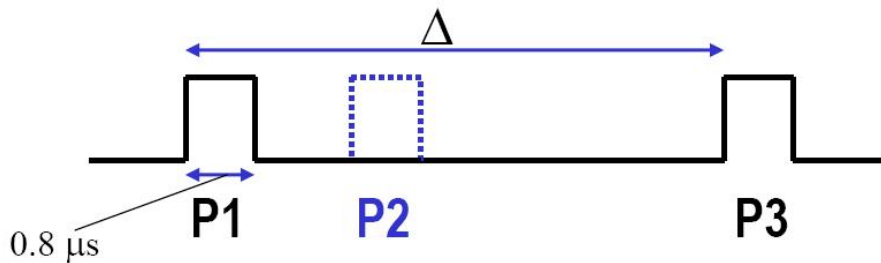

Figure 4 Example of secondary radar interrogation code

The Model 765 Series allows to produce the double pulses P1 and P3 with a user defined distance and duration, it offers excellent time resolution of 10 ps. The presence of multiple channels is perfect to supply the second pulse (P2) with a delay of 2 μs from the first one. A jitter under 25 ps ensures the perfect synchronization between channels.

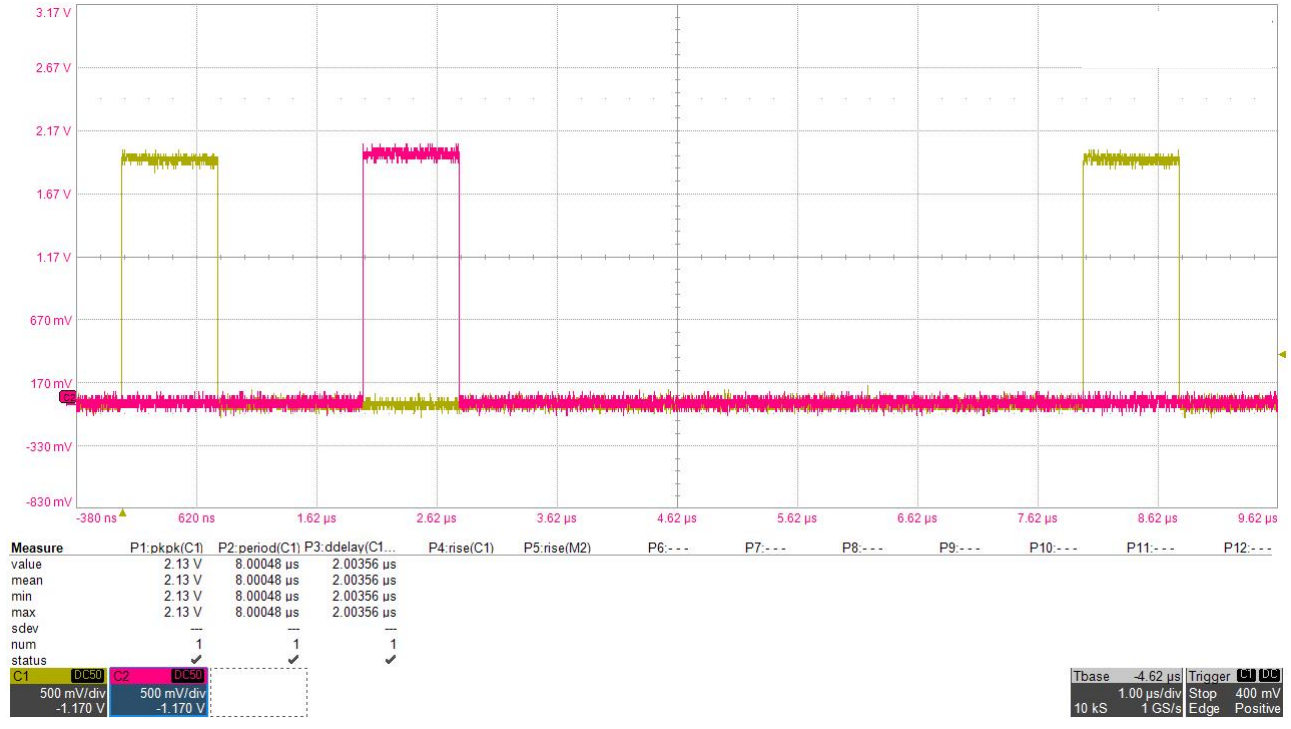
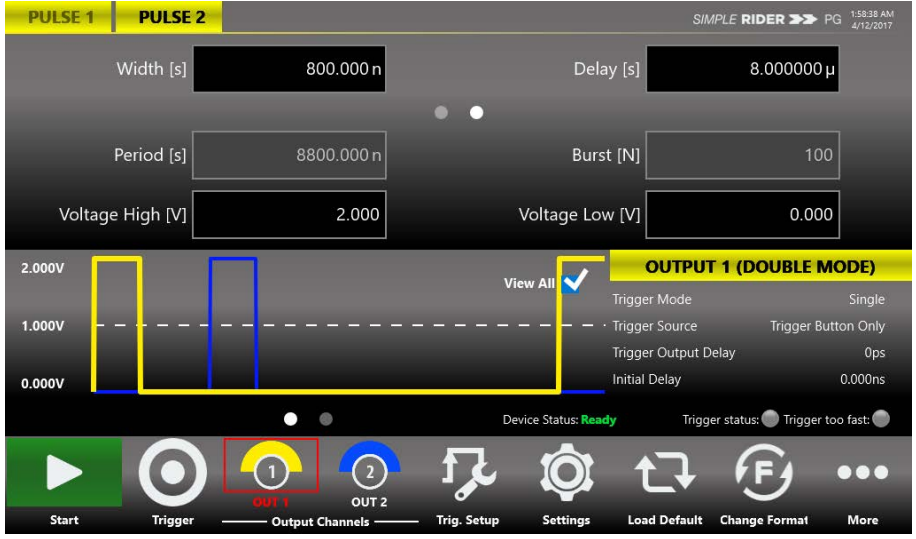

Figure 5 Secondary radar example of interrogation code (delay P1-P3= 8us)



PULSE 1 **PULSE 2** SIMPLE RIDER PG 1:58:38 AM 4/12/2017

Width [s] 800.000 n Delay [s] 8.000000 μ

Period [s] 8800.000 n Burst [N] 100

Voltage High [V] 2.000 Voltage Low [V] 0.000

2.000V 1.000V 0.000V View All **OUTPUT 1 (DOUBLE MODE)**

Trigger Mode Single

Trigger Source Trigger Button Only

Trigger Output Delay 0ps

Initial Delay 0.000ns

Device Status: Ready Trigger status: Trigger too fast

Start Trigger **1** OUT 1 2 OUT 2 Trig. Setup Settings Load Default Change Format More

Figure 6 Pulse Rider interface waiting for trigger-in signal

Multiple Target Simulation using a Pulse/Delay generator

In primary radar system the elaboration system measures the time of flight of the signal to calculate the distance from target; it extracts the distance using the following equation:

$Distance (km) = (Delay Time (sec) / 2) * 3 \times 10^5 km/s$, where $3 \times 10^5 km/s$ is an approximation of the light speed.

It means that the delay between the transmitted and the received signal depends on distance.

In case of multiple targets, multiple signals are received and the detection system must be able to distinguish between them.

The Model 765 pulse generator is the perfect choice to test the detection chain shorting the developing times without having the completely radar system and some targets to aim.

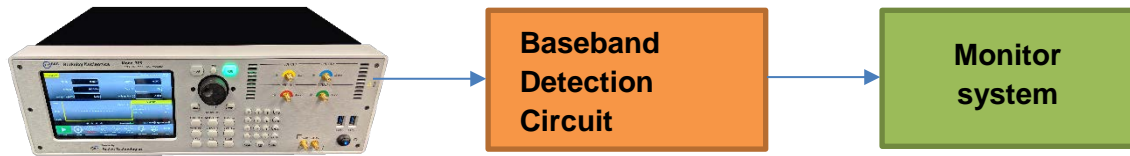

Figure 4 Example of detection circuit testing using Pulse Rider series

The multiple pulse mode offers double, triple and quadruple pulses with different duration and delay from trigger-in signal that can be repeated up to 125 MHz for testing the real-time frequency operation of the detection system.

The resolution of 10 ps and the jitter RMS below 25 ps give the necessary accuracy to take count of the RF chain expected delay and to simulate the detection of the target with a resolution under the centimetre.

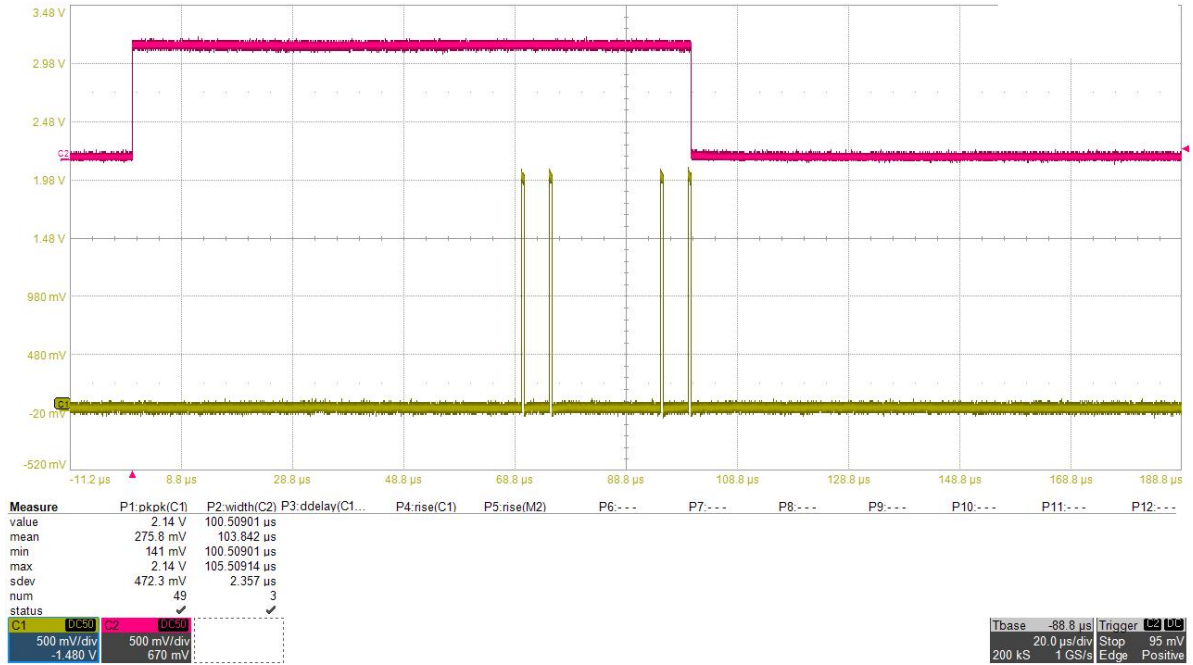

Figure 5 Example of quadruple pulses with a fixed delay from trigger-in signal to simulate the detection of multiple targets

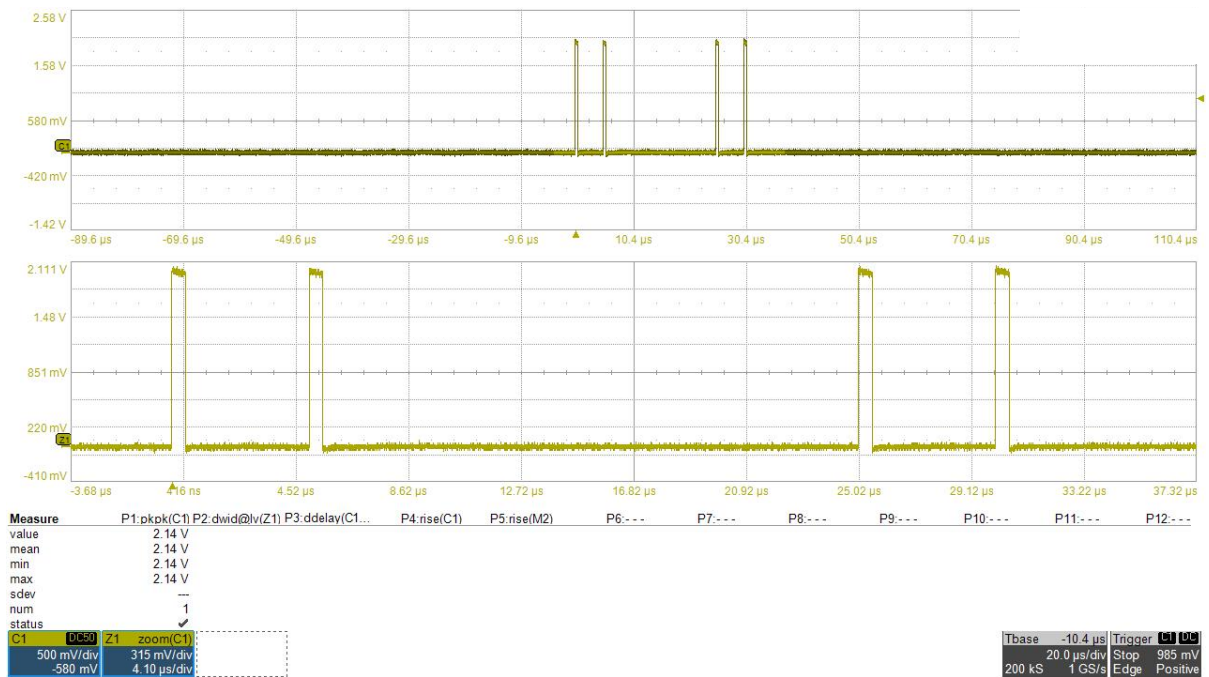

Figure 9 Zoom on quadruple pulse

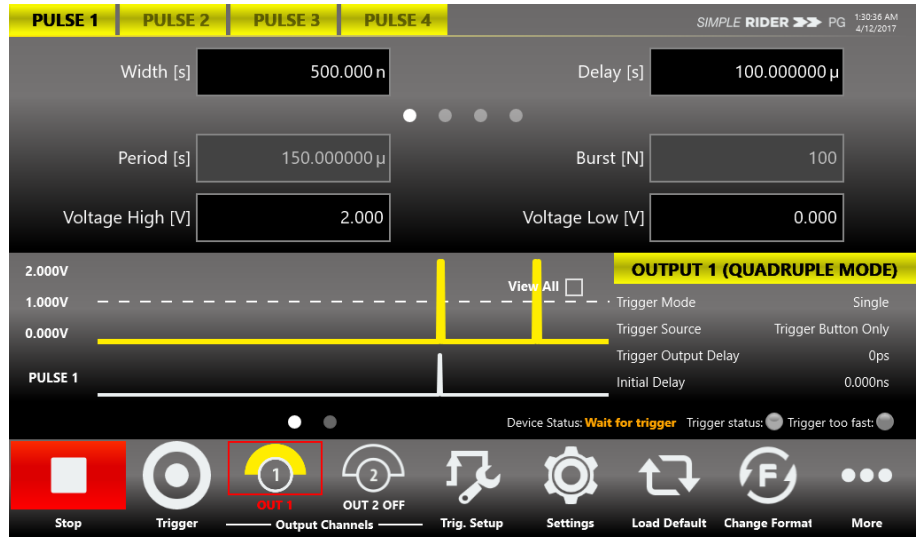

Figure 10 Pulse Rider interface waiting with quadruple pulse setting



About Active Technologies

Active Technologies is an Italian company expert in semiconductor test equipment and electronic instrumentation design.

About Berkeley Nucleonics Corporation

Berkeley Nucleonics Corporation (BNC) is a leading manufacturer of precision electronic instrumentation for test, measurement, and nuclear research. Our corporate headquarters are in San Rafael, California, with additional manufacturing facilities and sales offices located throughout the United States.

PULSE RIDER

The Pulse Rider Series offers premium signal integrity with the easiest to use touch screen display interface (SimpleRider™).

The Generation of pulses requires only a few screen touches.

Its innovative hardware architecture provides the possibility to generate multiple pulse sequences, such as double, triple or quad pulses, with fully independent timing parameters.