

Model 845 Specification 2.54 (Sep 2017)

Portable 12, 20, & 26.5 GHz Microwave Signal Generator

with options HP, PE, R, LN, FS & LO



NSCA Technologies & Tra-Cal Lab 7901 Beechcraft Ave., Ste. M & N, Gaithersburg, MD 20879
www.nscainc.com | info@nscainc.com | 1-888-280-6722 (toll-free #)

Introduction

The Model 845 Series is a series of low-noise and fast-switching microwave signal generators covering a continuous frequency ranges from as low as 100 kHz up to 12, 20, and 26.5 GHz, respectively, with a 0.001 Hz resolution.

The 845 Series provide an accurately levelled output power range and high spurious suppression. Advanced frequency synthesis with fractional-N divider makes for low SSB phase noise and micro-Hz resolution.

Available Options:

-**HP** delivers higher maximum output power to a level up to +27 dBm.

-**PE** is an optional power level extension to accurately level below -90 dBm.

-**LN** provides ultra low phase noise and further improves frequency stability

-**FS** substantially reduces the switching speed

-**LO** removes all built-in modulation capabilities if not needed (845-20, 845-26 only)

-**RB** adds an internal rechargeable battery module

-**R** modifies form-factor to a 19" rack-mountable 1HU enclosure

-**TP** modifies form-factor to a 3HU 19" bench-top enclosure with touch-display control

The standard Model 845 includes amplitude modulation (AM), DC-coupled, low distortion wideband frequency modulation (FM), PM, FSK and PSK, frequency chirp, and fast pulse modulation with internal pulse train generator. Three internal modulations sources are available.

All modulation modes of the Model 845 can be combined. This allows the generation of complex modulation signals for modern communication and location systems. The combination of pulse modulation and FM simulates Doppler effects or chirp signals. Simultaneous AM and pulse modulation provides the types of signal occurring in pulse radar applications with rotating antenna. The combination of FM and AM can be used to check fading effects of FM receivers.

All Model 845 allow fast analog and digital sweeps including flexible list sweeps, where frequency, power and dwell times can be set individually. A flexible triggering capability simplifies synchronization within test environments.

All Model 845's operate with an ultra-stable temperature compensated 100 MHz reference (OCXO) to ensure minimal drift, and can be phase-locked to any stable external reference in a range from 1 to 250 MHz. Additionally, optimum phase synchronous signals can be achieved by bypassing internal and feeding a 100 MHz signal directly as reference. The Model 845 supports various standard interfaces such as USB-TMC, LAN, and GPIB.

Applications for the Model 845 Series include

- R&D low noise microwave source
- Production testing (industry-leading switching times; high dynamic range)
- Service and maintenance (battery operation)
- Signal simulation (Radar, WiMax, UWB)
- Aerospace & Defence (Pulse modulator, Chirps)

Signal Specifications

The specifications in the following pages describe the warranted performance of the signal generator for $23 \pm 10^\circ\text{C}$ after a 30 minute warm-up period and for all configurations (options PE3 if not explicitly stated). Typical specifications describe expected, but not warranted performance. Min and Max specifications are warranted.

Parameter	Min.	Typ.	Max.	Note
CW mode				
Frequency range	100 kHz 100 kHz 100 kHz		12.0 GHz 20.0 GHz 26.5 GHz	845-12 845-20 , settable to 20.5 GHz 845-26, settable to 30 GHz
resolution		0.001 Hz		
Phase resolution		0.1 deg		
Frequency / Amplitude settling time		200 μs	300 μs 30 μs	time from receipt of SCPI command option FS
SSB Phase noise (standard)				
500 MHz				
10 Hz offset		-74 dBc/Hz		
1kHz offset		-126 dBc/Hz		
100 kHz offset		-137 dBc/Hz		
4 GHz				
10 Hz offset		-68 dBc/Hz		
1kHz offset		-108 dBc/Hz		
100 kHz offset		-119 dBc/Hz		
20 GHz				
10 Hz offset		-51 dBc/Hz		
1kHz offset		-91 dBc/Hz		
100 kHz offset		-104 dBc/Hz		
Wideband noise		-150 dBc/ Hz		
SSB Phase noise (option LN)				
200 MHz				
1 Hz offset		-89 dBc/Hz		
10 Hz offset		-115 dBc/Hz		
1kHz offset		-133 dBc/Hz		
100 kHz offset		-152 dBc/Hz		
10 MHz offset		-158 dBc/Hz		
4 GHz				
1 Hz offset		-62 dBc/Hz		
10 Hz offset		-88 dBc/Hz		
1kHz offset		-115 dBc/Hz		
100 kHz offset		-126 dBc/Hz		
10 MHz offset		-145 dBc/Hz		
20 GHz				
10 Hz offset		-74 dBc/Hz		
1kHz offset		-100 dBc/Hz		
100 kHz offset		-113 dBc/Hz		
10 Mhz		-130 dBc/Hz		
Amplitude Noise at 10 GHz		-130 dBc/Hz -140 dBm		Pout=+10 dBm, 100 kHz offset noise floor

Parameter	Min.	Typ.	Max.	Note
Output power				Check maximum output power plots on page 10
Standard 100 kHz to fmax	-20 dBm		+15 dBm	
Option PE3 only 100 kHz to fmax	-90 dBm		+13 dBm	
Option HP only	-20 dBm -20 dBm -20 dBm -20 dBm		18 dBm +25 dBm +23 dBm +18 dBm	< 20 MHz 0.2 to 6 GHz 6 to 16 GHz, see plot >16 GHz, see plot
Options HP and PE3	-20 dBm -90 dBm -90 dBm -90 dBm -90 dBm -90 dBm		18 dBm +22 dBm +20 dBm +18 dBm +15 dBm +13 dBm	< 20 MHz 0.2 to 10 GHz 10 to 16 GHz 16 to 20 GHz 20 to 24 GHz > 24 GHz
Level resolution	0.01 dB			
Level uncertainty, ALC on		0.3 dB 0.6 dB 3.0 dB 1.0 dB	1.0 dB 1.5 dB 3.0 dB 3.0 dB	-15 to +15 dBm -65 dBm to -15 dBm , option PE3 < -65 dBm, f<10 GHz option PE3 < -65 dBm, f>10 GHz option PE3 > 15 dBm to Pmax, option HP
Temperature effects User flatness correction		0.015 dB/ °C up to 2000 points		0 to 45 °C
Output impedance VSWR	50 Ω 1.5 2.0			< 20 GHz > 20 GHz
Reverse Power Protection				
DC Voltage			±15 V	
RF power			30 dBm	
Spectral purity at + 5 dBm Output harmonics		-40 dBc	-30 dBc	See plot
Sub-harmonics		-75 dBc -50 dBc	-65 dBc -40 dBc	< 20 GHz > 20 GHz
Non-harmonic spurious < 312 MHz > 312 to 625 MHz > 625 MHz to 1.5 GHz > 1.5 GHz to 2.5 GHz > 2.5 GHz to 5 GHz > 5 GHz to 10 GHz > 10 GHz to 20 GHz > 20 GHz		-80 dBc -75 dBc -75 dBc -70 dBc -65 dBc -60 dBc -55 dBc -50 dBc	-66 dBc -70 dBc -65 dBc -65 dBc -60 dBc -55 dBc -50 dBc -45 dBc	CW +10 dBm, > 3 kHz offset
Residual FM @ 10 GHz		15 Hz		0.3 kHz to 3 kHz, weighted (ITU-T), RMS
Residual AM @ 10 GHz		0.02 %		RMS value (0.01 kHz to 15 kHz)

Sweeping Capability

Sweeps can be performed with combined internal or external AM/FM/PM/pulse modulation running. With modulation enabled, the minimum step time increases to 2 ms.

Parameter	Min.	Typ.	Max.	Note
Digital power / frequency / list sweeps				
Sweep type: linear, logarithmic, random				
Step time (τ_{step})	400 μ s 40 μ s		19998 s	Option FS
Dwell time (τ_{val})	10 μ s		9999 s	
Off-time (incl. transient time) (t_{off})	0		9999 s	
Transient time (τ_{inv})			270 μ s 30 μ s	Option FS
Timing delay (τ_{de})		2 to 10 μ s		
		50 ns		Option FS
Time resolution		0.1 μ s 5 ns		Option FS
Timing accuracy per point		3 μ s 5 ns		Option FS

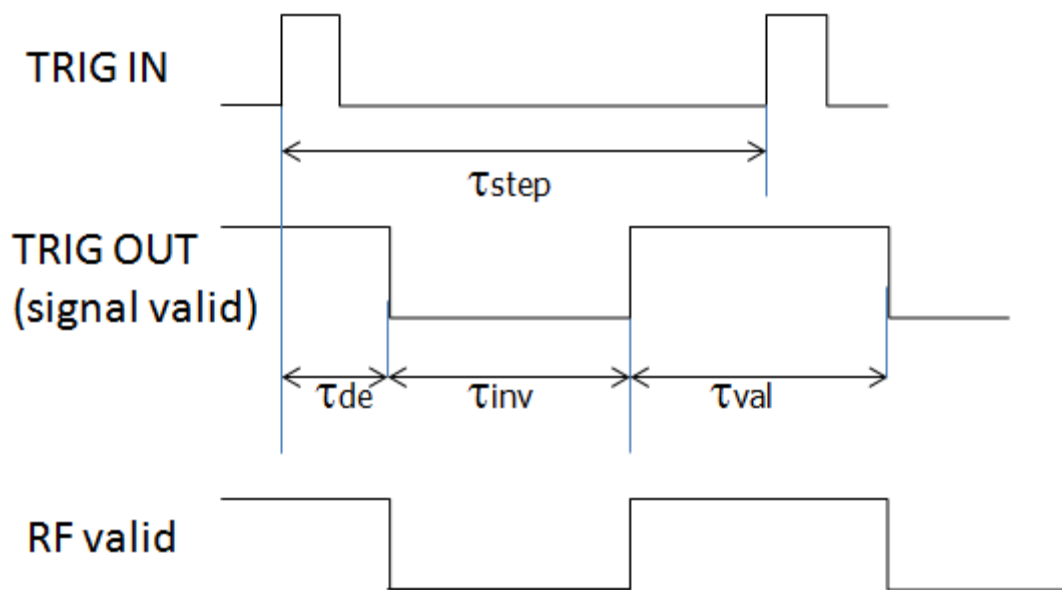

Frequency Chirps

(linear ramp, up/down)

Bandwidth	10 %			of carrier frequency
Dwell time (t_{dwell})	10 ns		10000 μ s	
Slope			100 MHz / μ s	
Number of frequencies			65'000	

Reference Frequency

REF IN input and REF OUT output are at rear panel

Parameter	Min.	Typ.	Max.	Note
Internal reference frequency		100 MHz 10 / 100 MHz		Option LN
Initial accuracy			±40 ppb	calibrated at 23 ± 3 °C at time of calibration , user adjustable
Temperature stability (0 to 50 degC)			±100 ppb ±20 ppb	Option LN
Aging 1 st year		0.5 ppm 0.1 ppm		Option LN
Aging per day (after 30days operations)			5 ppb tbm	Option LN
Warm-Up time		5 min		
Output of internal reference		10 MHz 10/100 MHz		
Output power		0 dBm		
Output impedance		50 Ohms		
Bypass Internal reference Input	100 MHz, -5 to +10 dBm 100 MHz, 1 GHz			High phase synchronous mode Option LN
Phase Lock to External Reference External Input Range	1 MHz		250 MHz	User programmable (not available with option LN)
Reference input level	-5 dBm	0 dBm	+13 dBm	
Lock Range			±1.5 ppm	
Reference input impedance		50 Ohms		

Multi Purpose Output (FUNC OUT)

Output is FUNC OUT at rear panel

Parameter	Min.	Typ.	Max.	Note
MULTIFUNCTION GENERATOR	sine, triangle, square wave			
Frequency range	1 Hz 1 Hz		3 MHz 1 MHz 50 kHz	sine triangle square
Frequency resolution		0.1 Hz		
Output voltage amplitude peak-peak	10 mV	5V	2 V	Sine, triangle Square (CMOS output)
Harmonic Distortion		1 %		< 100 kHz, 1 Vpp
Output impedance		50 Ohms CMOS		Sine, triangle square wave
VIDEO OUTPUT (of internal pulse modulator)				
Output		CMOS		
Period	30 ns		50 s	
Pulse Width	15 ns		50 s	

Parameter	Min.	Typ.	Max.	Note
RF delay		10 ns		
TRIGGER OUT Synchronization mode for multiple sources				
Modes		Trigger on sweep start Trigger on each point Signal Valid		Option FS

Trigger Input (TRIG IN)

Input is TRIG IN at rear panel

Parameter	Min.	Typ.	Max.	Note
Trigger Types	Continuous, single, gated, gated direction			
Trigger Source	RF key, external, bus (GPIB, LAN, USB)			
Trigger Modes	Continuous free run, trigger and run, reset and run			
Trigger latency		2 μ s 5 ns		Option FS
Trigger uncertainty		5 μ s 10 ns		Option FS
External Trigger delay	50 μ s 50 ns		40 s 10 s	programmable Option FS
External Delay Resolution		15 ns 10 ns		Option FS
Trigger Modulo	1		255	Execute only on Nth trigger event
Trigger Polarity	Rising, falling			

Trigger Output (TRIG OUT)

see Multi Purpose Output (FUNC OUT)

Modulation Capabilities (not with option LO)

Combined AM/PM/FM/PULSE possible (see user manual)

Parameter	Min.	Typ.	Max.	Note
Multifunction Generator sine, triangle, square wave Output is FUNC OUT at rear panel				
Frequency range	10 Hz 10 Hz		3 MHz 1 MHz 50 kHz	sine triangle square
Frequency resolution		0.1 Hz		
Output voltage amplitude peak-peak	10 mV	5V	2 V	Sine, triangle Square (CMOS output)
Harmonic Distortion		1 %		< 100 kHz, 1 Vpp
Output impedance		50 Ohms CMOS		Sine, triangle square wave
Pulse Modulation				
On/off ratio		80 dB		at +10 dBm
Repetition frequency	DC		10 MHz	
Pulse width	30 ns 500 ns			ALC hold ALC on
Pulse rise/fall time		7 ns		
Pulse width	30 ns		5 s	
Duty cycle	0.05 %		99.95 %	
Pulse resolution		15 ns		
Polarity		selectable		
External input amplitude		1 V TTL		AC DC
Pulse Pattern Modulation				
On/off ratio		70 dB		Using internal pattern generator at +10 dBm
Pulse bit width	30 ns 500 ns			ALC hold ALC on
Pulse rise/fall time		7 ns		
Programmable pattern length	2		4192	
Pulse width	30 ns		5 s	
Duty cycle	0.05 %		99.95 %	
Pulse bit resolution		10 ns 30 ns		
Polarity		selectable		
Frequency Modulation				
Maximum Frequency deviation (peak)		> 0.05·f N · 200 MHz		(not available with option LN) < 1.25 GHz 1.25 GHz to 2.5 GHz (N=0.125) 2.5 GHz to 5 GHz (N=0.25) 5 GHz to 10 GHz (N=0.5) > 10 GHz to 20 GHz (N=1)
Deviation accuracy				
< 100 kHz rate		0.5 %	2 %	
> 100 kHz rate		2 %	5 %	
Distortion		< 1 %		1 kHz rate, 50 kHz deviation
Modulation rate	DC		800 kHz	> -3dB frequency response

Parameter	Min.	Typ.	Max.	Note
Modulation waveforms	Sine, triangle, FSK			
External input sensitivity AC coupled DC coupled	0 to N · 200 MHz / V 0 to N · 100 MHz / V			adjustable for ±1 V range discr. values ; ±5 V range
Total harmonic distortion	< 1%			1 kHz rate & N · 1 MHz deviation
Phase Modulation				
Phase deviation (peak)	0		N·300 rad	(not available with option LN)
Modulation rate	DC		800 kHz	> -3dB frequency response Max. phase deviation degrades above 20 kHz modulation rate
Modulation waveforms	Sine, triangle, FSK			
External Input sensitivity	Settable 0.1 rad/V to 360 rad/V			
Total harmonic distortion	< 1%			1 kHz rate & N x 100 rad deviation
Amplitude Modulation				
Modulation rate	0.1 Hz		50 kHz	
Modulation waveforms	Sine, triangle, square			
Modulation depth	0 %		90 %	settable
Distortion (sine wave)		2 %		at 60% modulation depth
Accuracy (1kHz rate, 80%, 0dBm)				
< 5 GHz	X - 4%	X	X + 4%	
> 5 GHz	X - 6%	X	X + 6%	

Notes:

Typical performance curves

Phase Noise Performance (10 Hz to 50 MHz offset) at 1,4,13 and 26 GHz

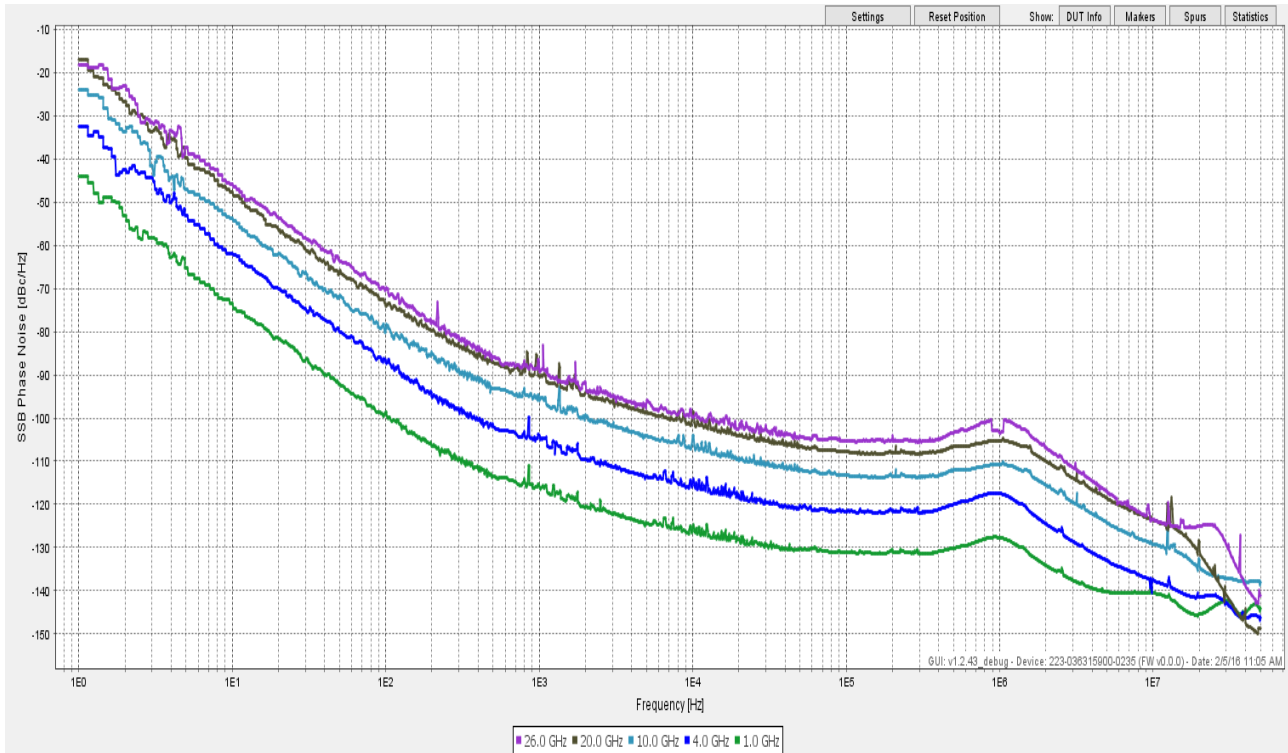

Phase Noise with Option LN

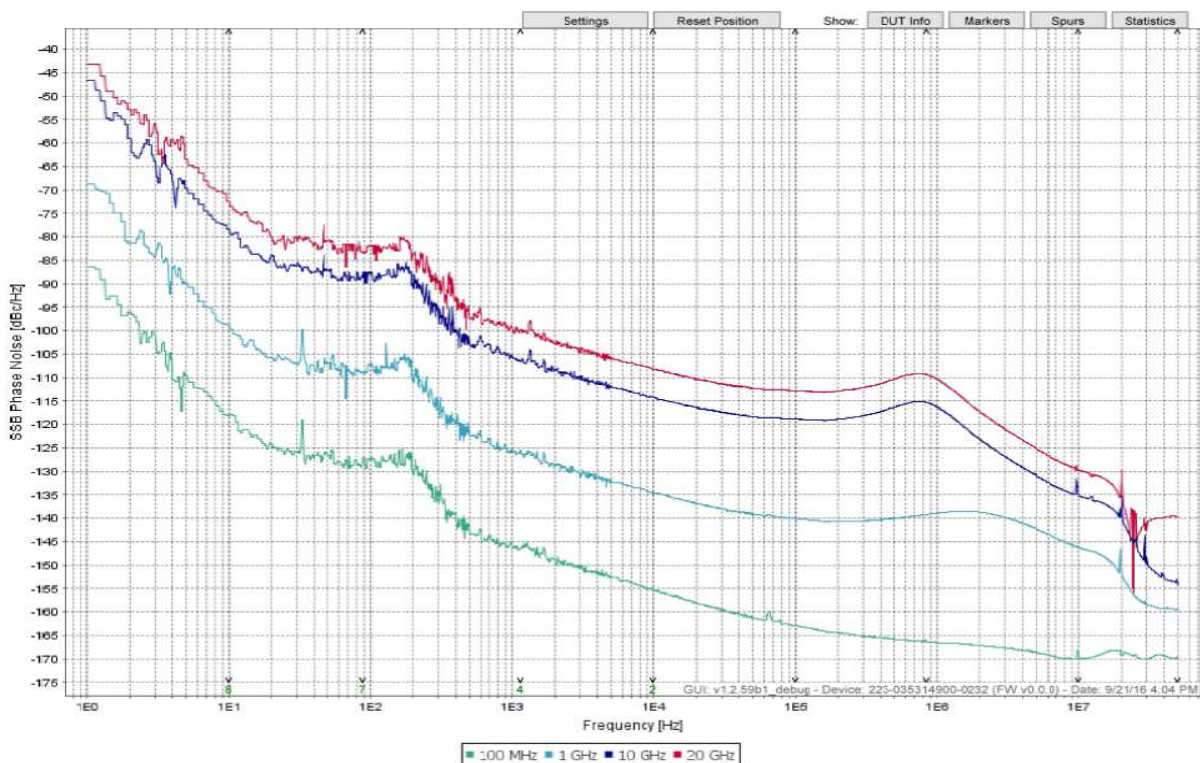

Typical Switching transient from 12 GHz to 14 GHz step

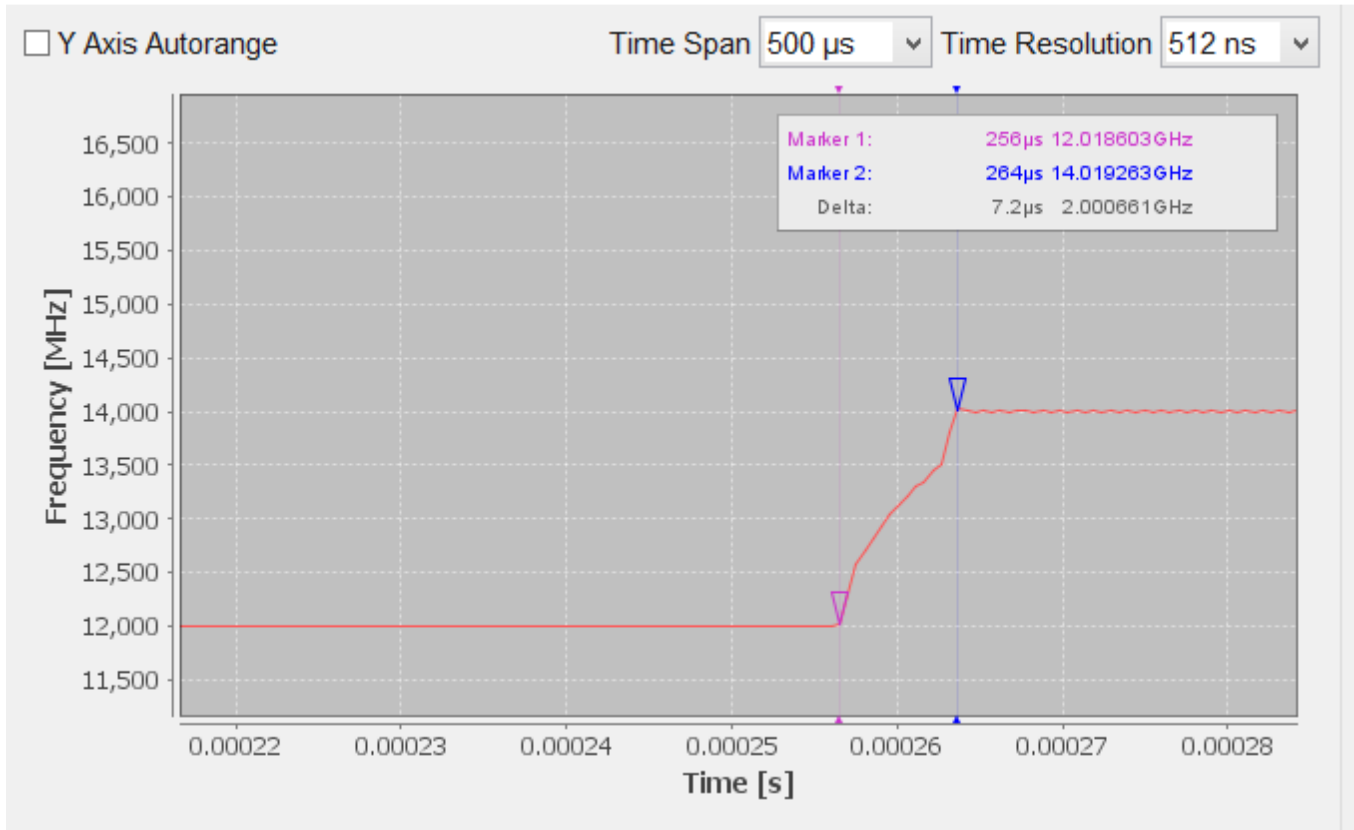

Typical Frequency Response 0 to 20 GHz at -20, 0, and +20 dBm

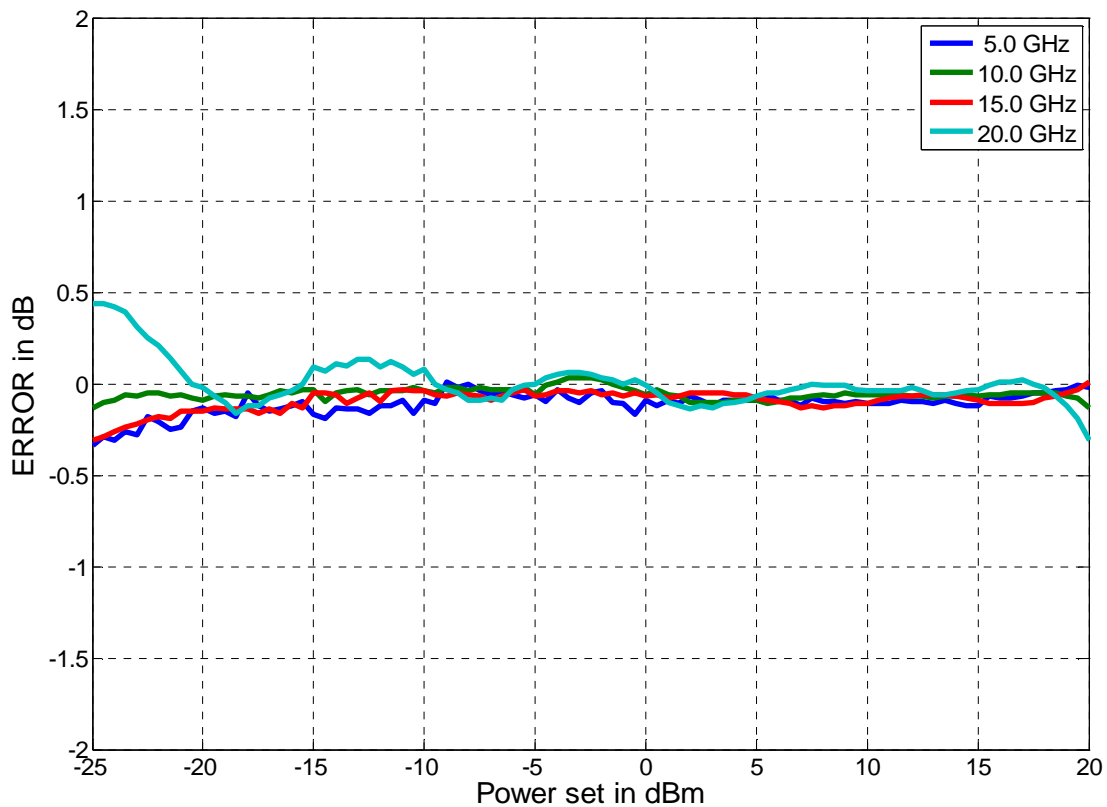
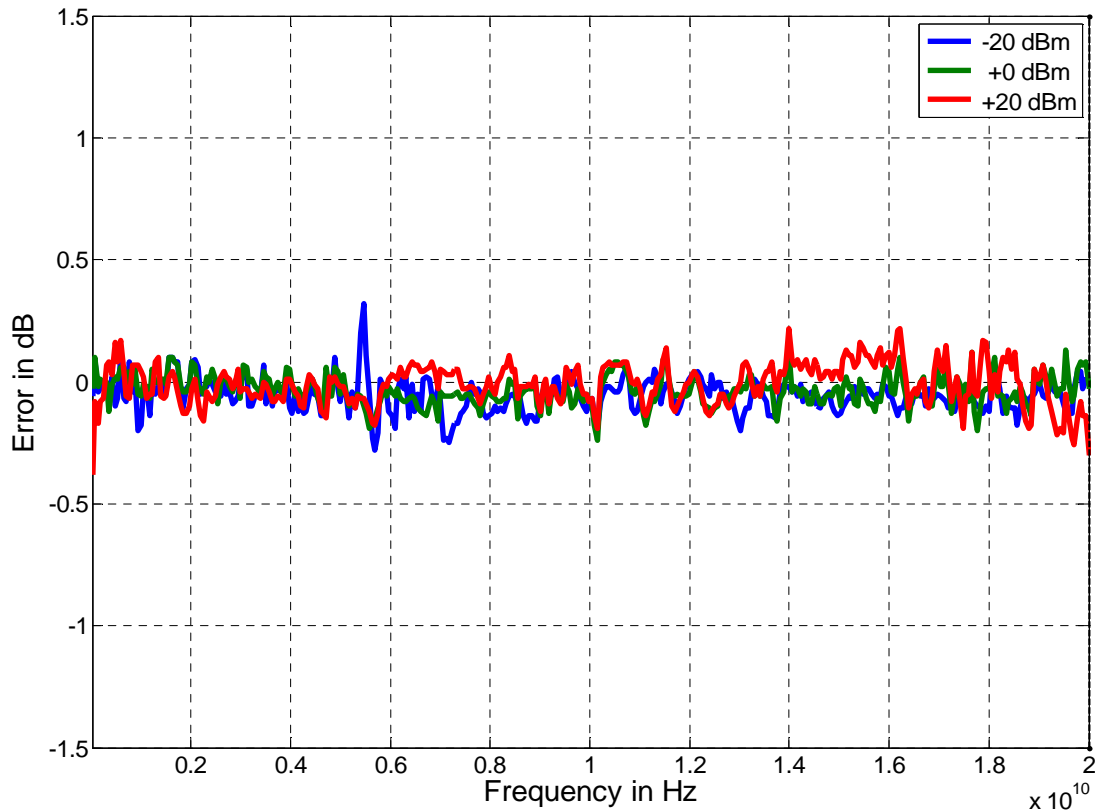

Typical Maximum Output Power (standard)

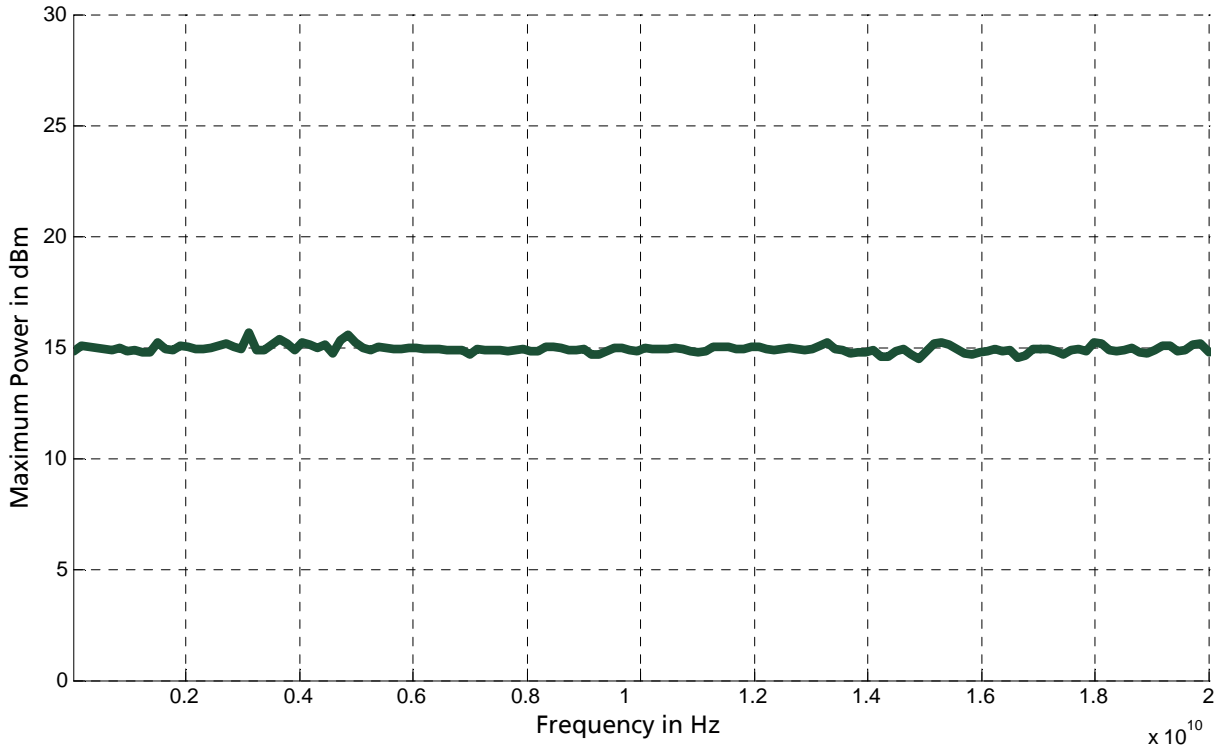

Typical Maximum Output Power (option HP)

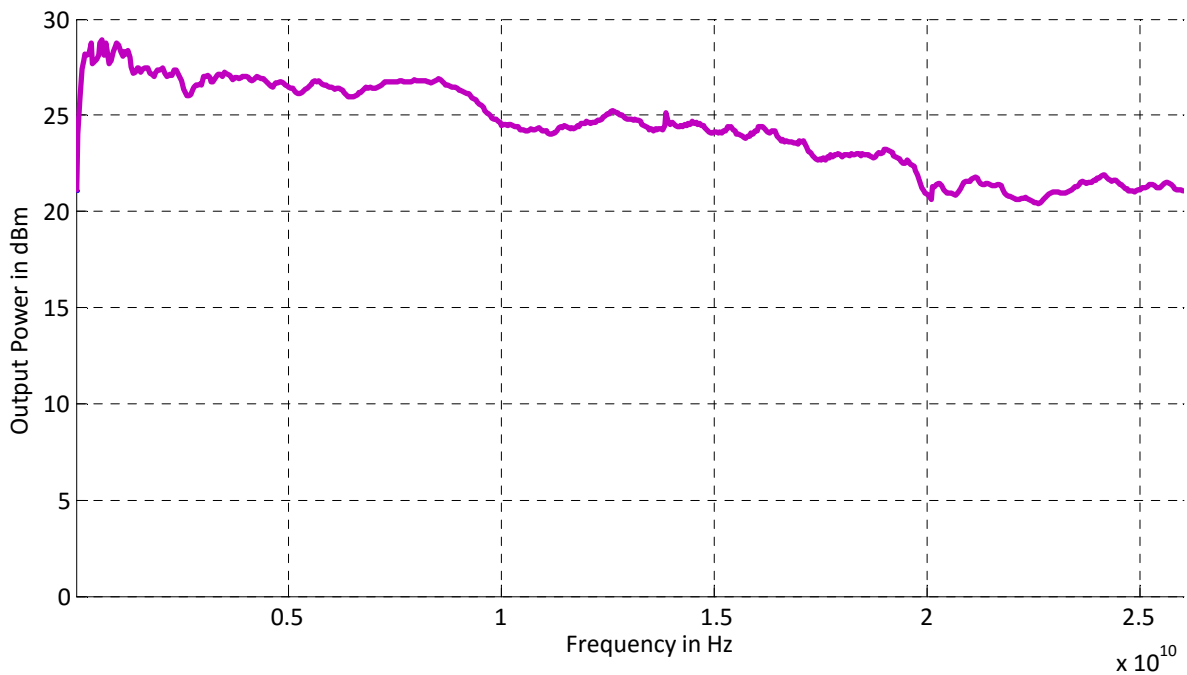

Typical Maximum Output Power (options PE and HP)

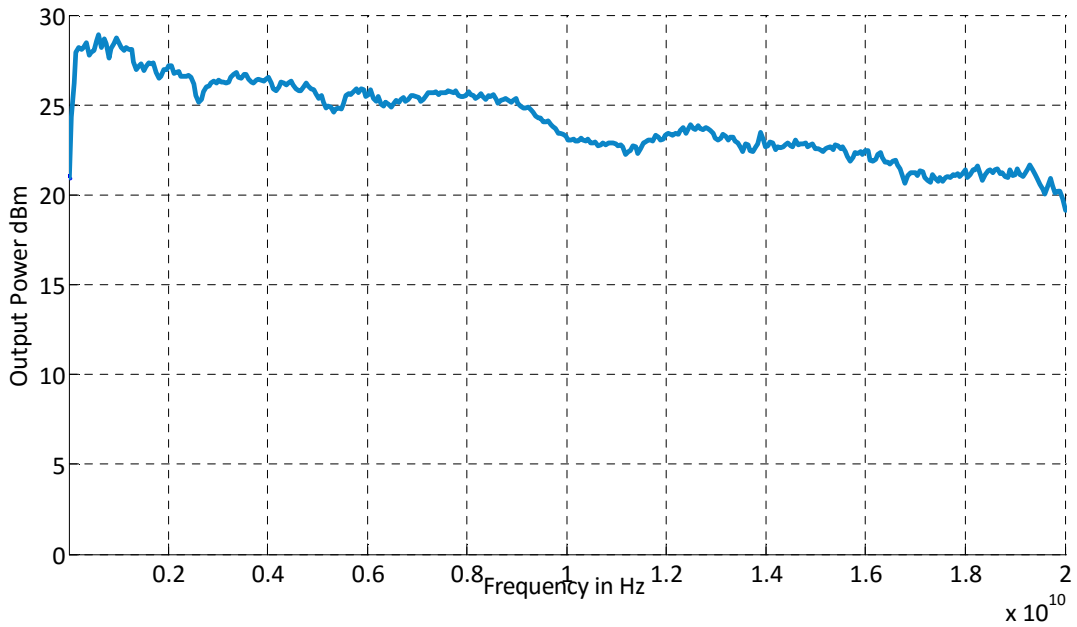

Harmonics (with option PE)

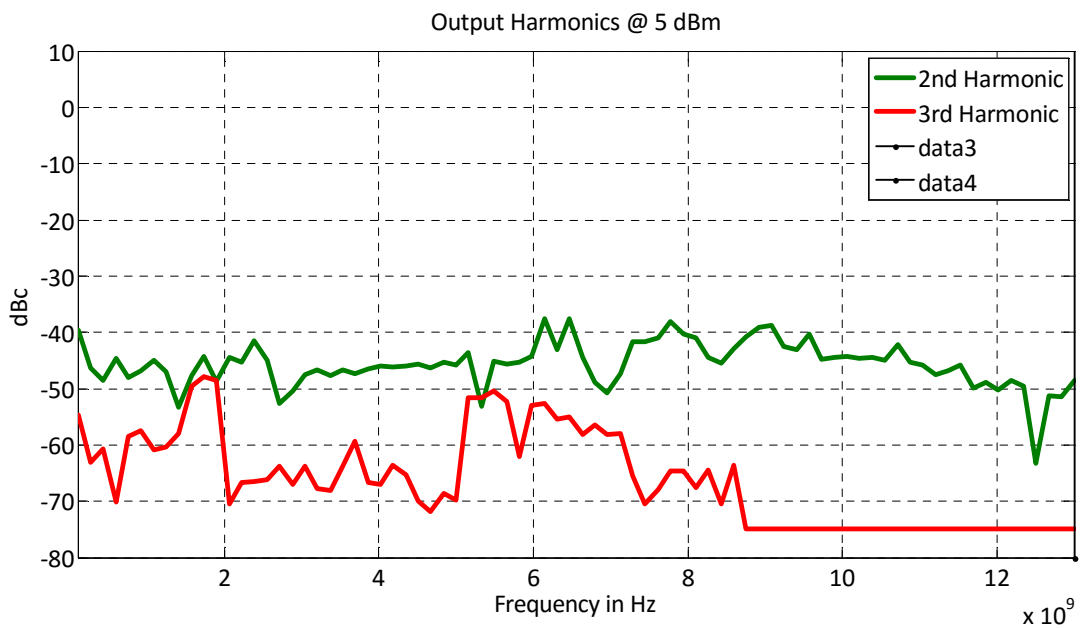

Connectors

Front panel:



1. **Main LCD display** The main display shows the following information:
 - 1st line: RF frequency in Hz
 - 2nd line: RF amplitude in dBm
 - 3rd line: Frequency reference status (internal, external, lock status)
 - 4th line: Remote control status
2. **Rotary Button** The rotary button is used to change the value selected on the screen.
3. **RF 50 Ω connector** This female N- type respectively SMA connector provides the output for generator signals. The impedance is 50 ohm. The reverse power damage level is +30 dBm maximum. The maximum allowed DC level is +/- 10 V. Please check the data sheets for more details.
4. **Menu Buttons** The menu buttons are used to change the selected menu point or value.
5. **Main Menu Button** The main menu button is used to enter the menu.
6. **RF On/Off button** The **ON/OFF** key toggles between RF output on and RF output off. The green light is indicating whether the RF output is enabled (light on) or disabled (light off).
7. **Power LED** The power LED is indicating whether the device is on or off.
8. **Remote LED** The remote LED is indicating whether the device is connected to a computer or not.

Rear panel:

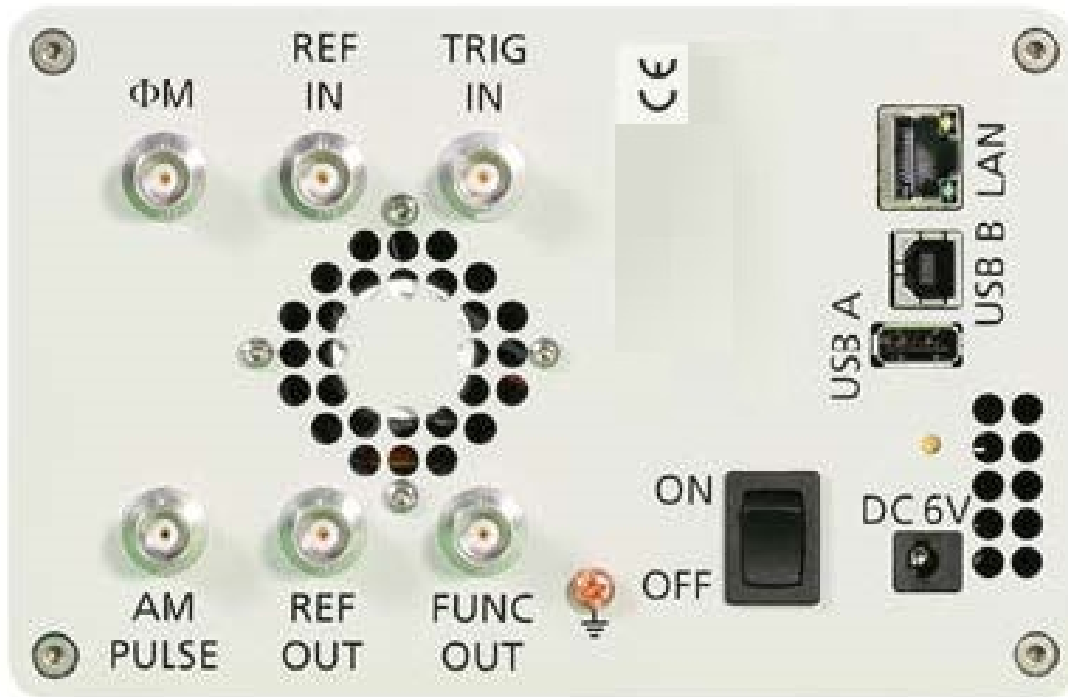

1. **ΦM** This BNC female Connector is the input for FM and PM.
2. **REF IN** This BNC female Connector is the input for the reference signal.
3. **TRIG IN** This BNC female Connector is the trigger input.
4. **USB B** The USB B connector is used to connect the device to a computer.
5. **LAN** The LAN connector is used to connect the device to a network.
6. **Battery LED** In case the device has a rechargeable battery, this LED indicates whether the battery is charged or not.
7. **Fan Holes** The air intake of the fan.
8. **Power Supply** Connect the Anapico power adaptor to this connector to supply the device with energy.
9. **ON/OFF Switch** Turns the device on or off.
10. **Ground Screw**
11. **FUNC OUT** This BNC female Connector is the output for the function signal.
12. **REF OUT** This BNC female Connector is the output for the reference signal.
13. **AM PULSE** This BNC female Connector is the input for the AM and the PULSE Modulation signal.
14. **Fan Holes** The holes by which the air is extruded.

REF:032917

General Characteristics

Remote programming interfaces

Ethernet 100BaseT LAN interface,
USB 2.0 host & device
GPIB (IEEE-488.2,1987) with listen and talk (optional)
Control language SCPI Version 1999.0

Power requirements 6.25 ± 0.2 VDC ; 20 W maximum

Mains adapter supplied: 100-240 VAC in/ 6 V 6.0 A DC out

Environmental (Levels similar to MIL-PRF-28800F Class 3/4)

Environmental stress Samples of this product have been type tested to be robust against the environmental stresses of storage, transportation, and end-use; those stresses to temperature, humidity, shock, vibration, altitude, and power line conditions.

Operating temperature range 0 to 40 °C

Storage temperature range -40 to 70 °C

Operating and storage altitude up to 15,000 feet (4600 m)

CE notice

EMC complies and EMC regulations and directives for emission and immunity to interference (EN 61326-1 Industrial, EN/IEC 61326-2-1)

Safety complies with applicable Safety regulation in line with IEC/EN 61010-1

Weight ≤ 2.5 kg (6 lbs) net, ≤ 4 kg (8 lb.) shipping

Dimensions 106 mm H x 172 mm W x 270 mm L (incl. connectors)
[4.21 in H x 6.77 in W x 10.63 in L]

Recommended calibration cycle 24 months

Options

- **HP:** High output power
- **PE3:** Extended power range down to <-90 dBm) step attenuator module
- **NM:** remove modulation
- **LN:** ultra low phase noise, improved frequency stability
- **FS:** enhanced switching speed
- **B3:** battery module
- **TP:** 3HE enclosure with touch display. Dimensions incl. rubber: 154 mm H x 467.5 mm W x 342 mm L [6.1 in H x 18.4 in W x 13.5 in L]
- **GPIB:** IEEE-488.2,1987 programming interface



- **1URM:** 19" 1HE enclosure with rack-mount capability. Dimensions 42 mm H x 426 mm W x 460 mm L [1.7 in H x 16.8 in W x 18.1 in L]



- **GPIB:** IEEE-488.2,1987 programming interface



- **RM:** 19" rackmount kit: good for one or two adjacent MODEL 845

Document History

Version/Status	Date	Author	Notes
V10	2010-06-01	jk	first release
V11	2010-08-30	jk	added specs for VSWR, AM noise, residual
V13	2010-10-15	jk	power, frequency range, modulation specs updated
V14	2011-04-28	jk	Frequency and power range , Output connector, added phase noise plot
V160	2013-08-26	db	Modified sweep timing specs, added max power measurement plots
V20	2014-07-30	jk	Combined MODEL 84520G and option HP
V21	2014-11-10	jk	Added pulse pattern specs
V22	2014-12-10	jk	Unified data sheet for MODEL 845XXG
V23	2015-1-15	jk	Added max. power plots
V240	2015-10-29	jk	Clarified switching speed, Phase noise revised
V241	2015-12-18	jk	Power level accuracy refined
V241	2016_01-12	jk	Refined spurious specs
V245	2016_03-04	jk	Included ALC temp effects, renewed phase noise plots
V246	2016_04-04	jk	Power level accuracy option dependant
V247	2016_06-21	jk	Internal pulse modulation max pulse width corrected
V248	2016_07-15	jk	Power level accuracy for PE3 option
V249	2016_09-15	jk	Option LN data refined
V250	2016_11-15	jk	Option LN data refined
V251	2017-03-30	jk	VSWR adjusted
V252	2017-05-30	jk	New front / rear plots
V253	2017-07-10	jk	Max power specifications refined for low frequency range
V254	2017-09-7	jk	Refined FM specs