

Keysight Technologies

Millimeter Wave Network Analyzers (N5290A/N5291A)

Configuration Guide



For more information:

Contact your NSCA & Tra-Cal Small Business Partner:

Email info@nscainc.com or call your local sales rep today at 301-527-9200.



Table of Contents

Introduction.....	3
Millimeter Wave Network Analyzer Configurations	5
Supported N5290/91A System Components	5
N5290A System Configurations.....	6
N5291A System Configurations.....	7
System Block diagrams	8
Configuring Broadband Using Separate System Components.....	11
Step 1: Supported PNA Configurations.....	11
Step 1: Supported PNA-X Configurations.....	11
Step 2: N5292A Millimeter wave test controllers.....	12
Step 3: N5293/5A Millimeter wave frequency extenders	12
Configuring OML and VDI Banded Frequency Extenders with N5290/91A.....	13
Supported Software Application Options.....	13
Measurement Applications.....	14
On-Wafer Measurements	14
Material Measurements.....	14
N1500A materials measurement suit	14
Antenna Measurements Solutions.....	14
Measurement Accessories	15
85059B DC to 120 GHz 1.0 mm Calibration kit.....	16
85059V 1.0 mm Verification kits.....	16
General Accessories	17
Frequency extender bias tee adapter kit (N5290A301).....	17
Frequency extender desktop positioner (N5290A302)	17
Broadband frequency extender transit case (N5290A303)	18
4 in-lb. 14 mm open end torque wrench (P/N: 8710-2813)	18
Cable adapter for OML/ VDI frequency extenders (N5290A304).....	18
Rack mount kis.....	18

Introduction

This guide describes the available configurations for Keysight's millimeter wave vector network analyzer (VNA) solutions and should be used in conjunction with the N5290A and N5291A datasheets. Both N5290A and N5291A systems come fully configured with hardware and options to enable broadband S-parameter measurements. Additional measurement application software can be added to the basic configurations.

This document will focus on the system architecture, describe the various application solutions, and available accessories. In addition, it will provide configuration information for creating a broadband solution using separate system components.

The N5290A and N5291A millimeter wave vector network analyzer is a network analyzer solution that utilizes both the PNA and PNA -X platforms as the measurement engine.



N5290A 4-Port Millimeter Wave Network Analyzer
900 Hz (500 Hz) to 110 GHz



N5291A 4-Port Millimeter Wave Network Analyzer
900 Hz (500 Hz) to 120 GHz (125 GHz)



N5290A 2-Port Millimeter Wave Network Analyzer
900 Hz (500 Hz) to 110 GHz



N5291A 2-Port Millimeter Wave Network Analyzer
900 Hz (500 Hz) to 120 GHz (125 GHz)

Common Options

The following set of service and warranty options are available on both the N5290A and N5291A.

Certification options¹

Commercial calibration certification with test data (Option UK6)

Complete set of measurements which tests unit to manufacturer's published specifications. Includes calibration label, calibration certificate, and data report. Conforms to ISO 9001.

ISO 17025 compliant calibration (Option 1A7)

Complete set of measurements which tests unit to manufacturer's published specifications. Includes calibration label, ISO 17025 calibration certificate, and data report, measurement uncertainties and guardbands on all customer specifications. Conforms to ISO 17025 and ISO 9001.

ANSI Z540 compliant calibration (Option A6J)

Complete set of measurements which tests unit to manufacturer's published specifications. Includes pre- and post-adjustment data with measurement uncertainty information compliant to the ANSI/NCSL Z540 standard.

Documentation

The PNA Series instruments are equipped with an Online Help system available within the instrument in English only. All PNA documentation is available on the web:

www.keysight.com/find/pna

Calibration Software Licenses

Built-in performance test software for standard compliant cal (S93898A) Adds built-in performance testing and calibration software for self-maintainers. Requires additional equipment. See the analyzer's Service Guide for more information on equipment required.

Warranty and service²

3- and 5-year warranty and service plans are available at the time of instrument purchase. Standard warranty is 3 years.

1. Only available on a fully configured system and not when system components are purchased separately.
2. On site repair is defined as on-site troubleshooting of the N5290/91A and repair ONLY of the PNA/PNA-X in the system. The N5292 and the N5293/5A are return to Keysight

Millimeter Wave Network Analyzer Configurations

Supported N5290/91A system components

N5290/91A supported PNA/PNA-X hardware:

PNA/PNA-X	Frequency coverage	Test set configuration
N5222B	900 Hz to 26.5 GHz	2-Port with Option 205
N5227B	900 Hz to 67 GHz	2-Port with Option 205
N5242B	900 Hz to 26.5 GHz	4-Port with Option 425
N5242B	900 Hz to 26.5 GHz	4-Port with Options 425, 029
N5247B	900 Hz to 67 GHz	4-port with Options 425,029

N5290/91A system supported millimeter wave test set controller configurations:

The N5290 and N5291A systems include either a 2-Port (Option 200) or a 4-Port (Option 400) and includes the following interconnect kit options.

PNA/PNA-X Models		N5292A Test options/ Interconnect cable options	
		2-Port test set controller (N5292A Option 200)	4-Port test set controller (N5292A Option 400)
2-Port PNA	N5222B	Option 222 Interconnect kit for 2-port test set and 2-port VNA with 3.5 mm ports	n/a
	N5227B	Option 224 Interconnect kit for 2-port test set and 2-port VNA with 2.4mm or 1.85 mm ports	n/a
4-Port PNA-X	N5242B	n/a	Option 442 Interconnect kit for 4-port test set and 4-port VNA with 3.5 mm ports
	N5247B	n/a	Option 444 Interconnect kit for 4-port test set and 4-port VNA with 2.4mm or 1.85 mm ports

N5290/91A system supported millimeter wave frequency extenders:

PNA/PNA-X	Frequency coverage	Bias tee configuration	Cable length
N5293AX03	900 Hz to 110 GHz	Low frequency bias combiner with built-in 50V 1A bias tee	1.2 m cable option
N5295AX03	900 Hz to 120 GHz	Low frequency bias combiner with built-in 50V 1A bias tee	1.2 m cable option

N5290A Pre-configured system options

The N5290A system comes preconfigured and will operate from 900 Hz to 110 GHz and it includes five different options. Each option below comes with either a 2- or 4-port PNA or PNA-X, the N5292A millimeter wave test set controller for 2- or 4-port measurements, and the N5293AX03 110 GHz frequency extenders. The system includes all the interconnect cables required to connect the PNA or PNA-X to the controller.

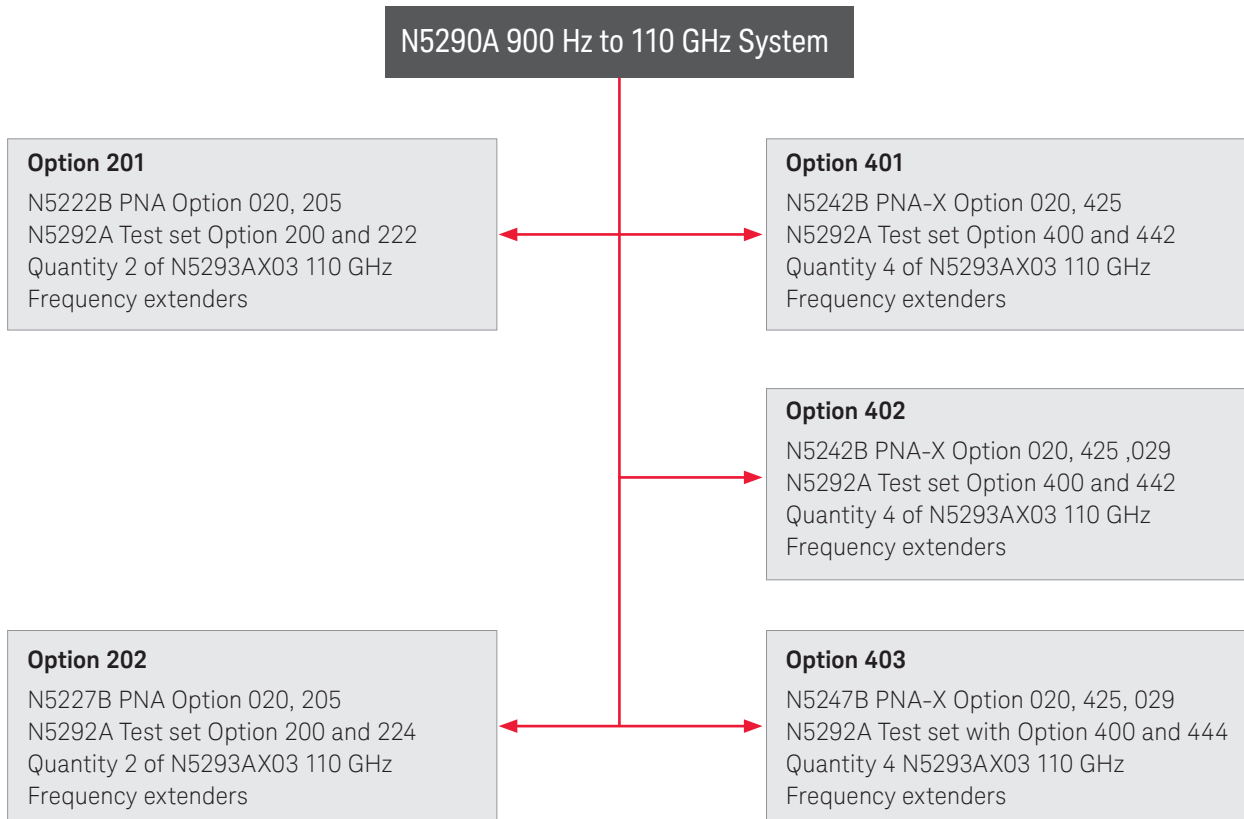

Note: For details or to add other PNA or PNA-X options to the above listed minimum configuration please refer to the PNA Family Configuration Guide (literature number 5992-1465EN).

Key features of the N5290A

- Standard frequency range 900 Hz to 110 GHz
- Extended frequency range of 500 Hz to 110 GHz
- Max output power limited to 0 dB from 90 GHz to 110 GHz
- Built in 50V, 1A Kelvin Bias Tee
- Magnitude stability of ± 0.015 dB over 24 hours across the frequency range
- Phase stability of ± 0.15 degrees over 24 hours across the frequency range
- Available in 2-port and 4-port configurations
- Compact module design N5293AX03, with no cooling fans
- Smart modules with built-in thermal management
- Factory calibrated source power at 1.0 mm port
- On wafer fixturing for existing Cascade probe stations
- Ruggedized IEEE 1287-2007 standards compliant 1.0 mm test port connector

N5291A Pre-configured system options

The N5291A system comes preconfigured and operates from 900 Hz to 120 GHz and it includes five different options. Each option below comes with either a 2- or 4-port PNA or PNA-X, the N5292A millimeter wave test set controller for 2- or 4-port measurements, and the N5295AX03 120 GHz frequency extenders. The system includes all the interconnect cables required to connect the PNA or PNA-X to the controller.

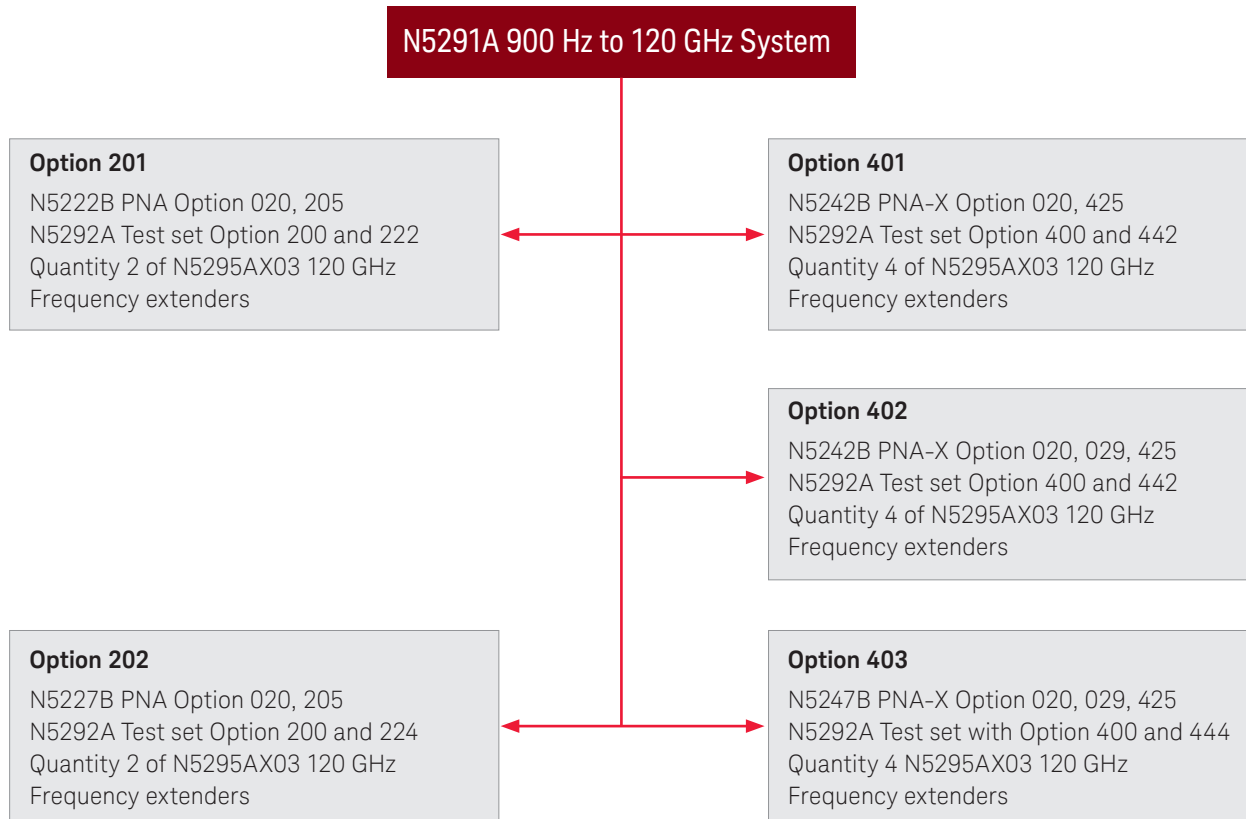

Note: For details or to add other PNA or PNA-X options to the above listed minimum configuration please refer to the PNA Family Configuration Guide (literature number 5992-1465EN).

Key features of the N5291A

- Standard frequency range 900 Hz to 120 GHz
- Extended frequencies 500 Hz to 125 GHz
- Max output power greater than 1 dBm (6 dBm typical) at 110 GHz
- Built in 50V, 1A Kelvin Bias Tee
- Magnitude stability of ± 0.015 dB over 24 hours across the frequency range
- Phase stability of ± 0.15 degrees over 24 hours across the frequency range
- Available in 2-Port and 4-Port configurations
- Compact module design N5295AX03, with no cooling fans
- Smart modules with built-in thermal management
- Factory calibrated source power at 1.0 mm port
- On wafer fixturing for existing Cascade probe stations
- Ruggedized IEEE 287-2007 standards compliant 1.0 mm test port connector

System block diagrams

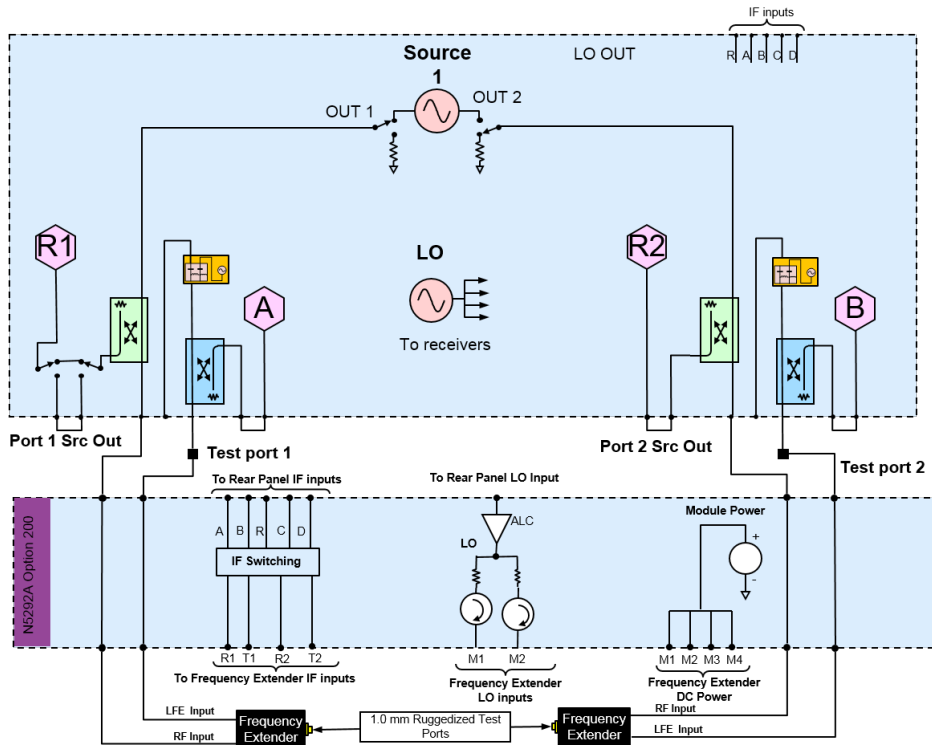

N5290/91A Option 201 System level block diagram (N5222B with Option 205)

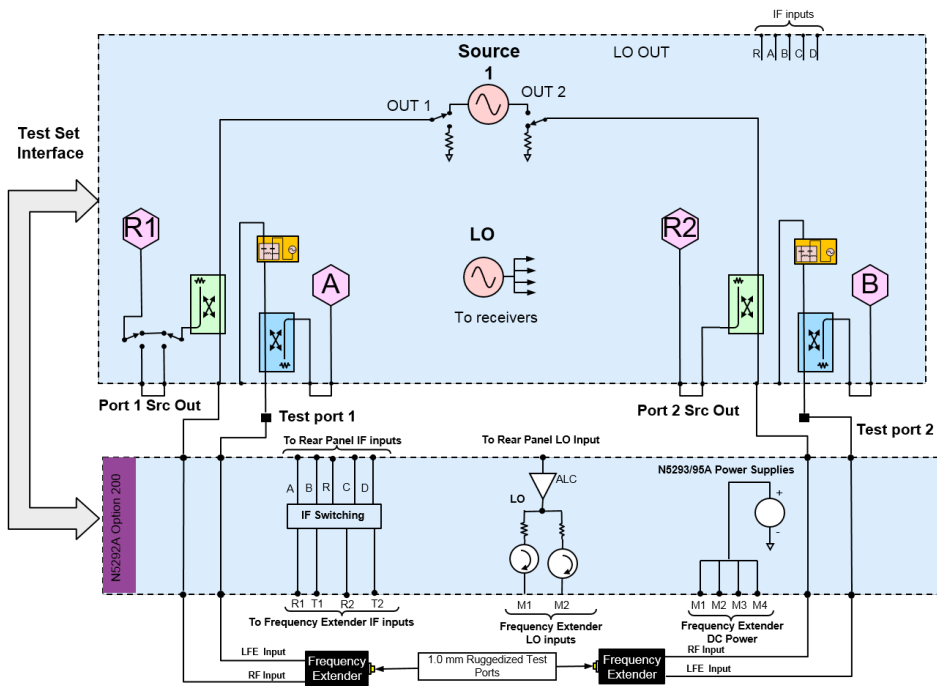

N5290/91A Option 202 System level block diagram (N5227B with Option 205)

System block diagrams (continued)

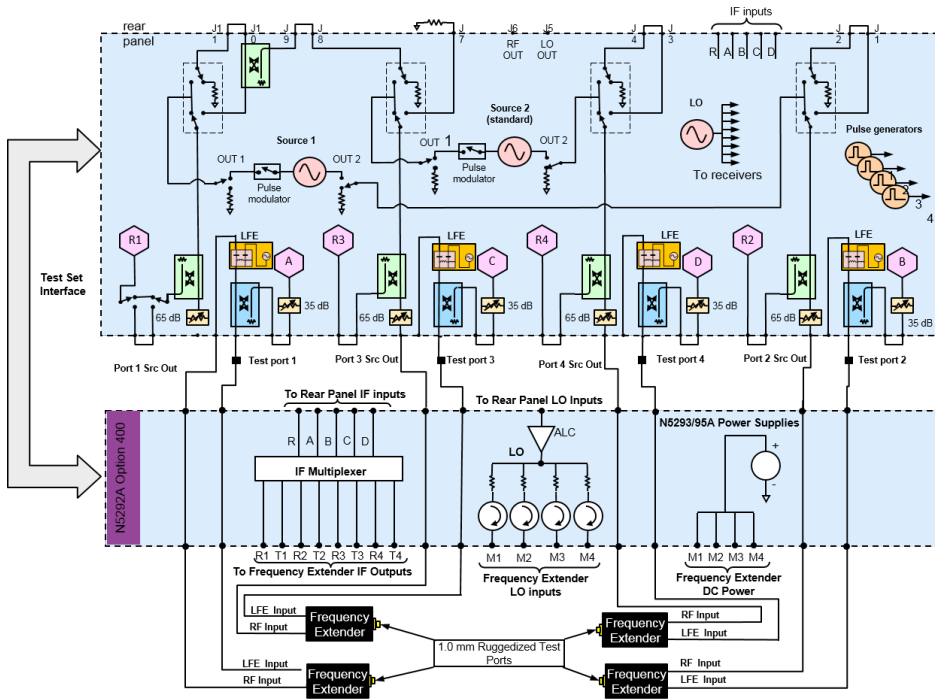

N5290/91A Option 401 System level block diagram (N5242B with Option 425)

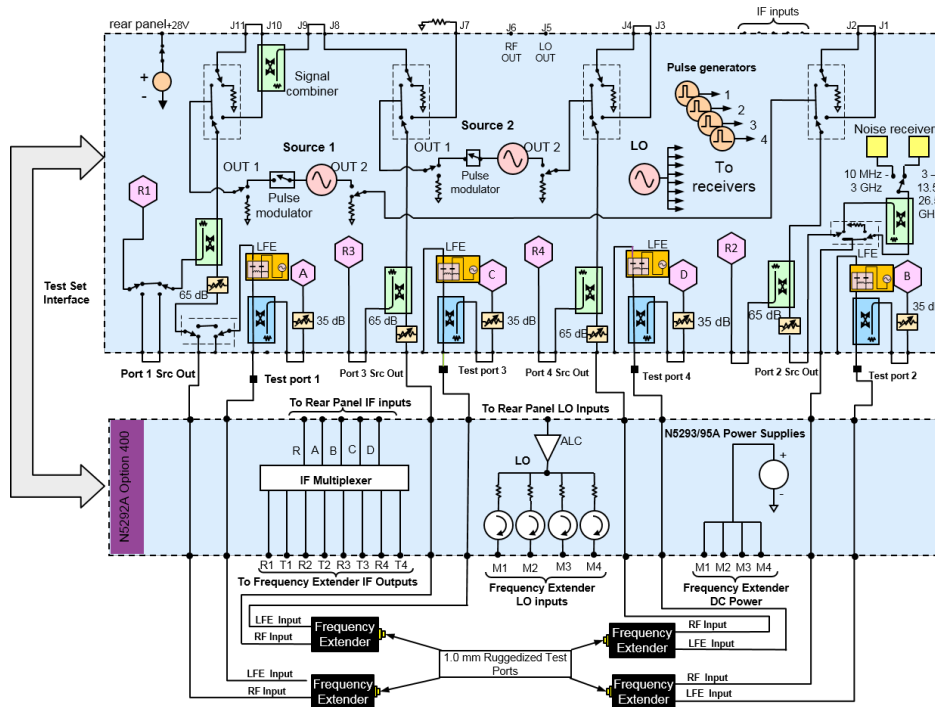

N5290/91A Option 402 System level block diagram (N5242B with Option 425, 029)

System block diagrams (continued)

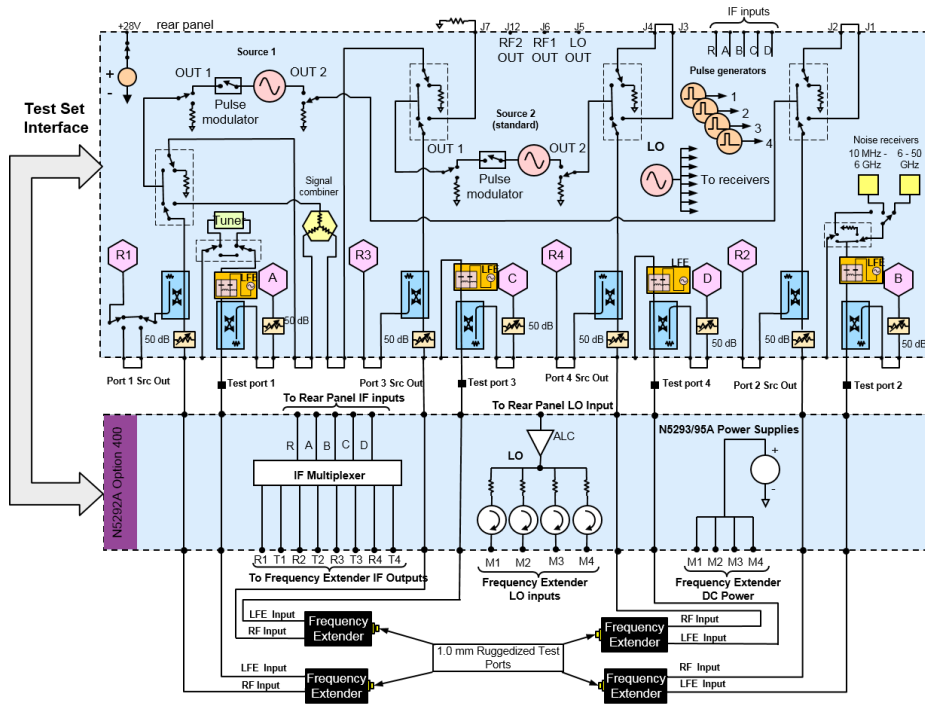

N5290/91A Option 403 System level block diagram (N5247B with Option 425,029)

Configuring Broadband Using Separate System Components

To configure a broadband system follow these 3 simple steps:

1. Select 1 of the PNA or PNA-X models in the tables below
2. Select the N5292A test set with the correct interconnect cable options
3. Select the N5293A or N5295A frequency extender

Step 1: Supported PNA Configurations

Product/ option ^{1,2}	Description	Low frequency extension
N5222B-201	26.5 GHz 2-Port PNA with configurable test set option	Option 205 ³
N5222B-401	26.5 GHz 4-Port PNA with configurable test set option	n/a
N5224B-201	43.5 GHz 2-Port PNA with configurable test set option	n/a
N5224B-401	43.5 GHz 4-Port PNA with configurable test set option	n/a
N5225B-201	50 GHz 2-Port PNA with configurable test set option	n/a
N5225B-401	50 GHz 4-Port PNA with configurable test set option	n/a
N5227B-201	67 GHz 2-Port PNA with configurable test set option	Option 205 ³
N5227B-401	67 GHz 4-Port PNA with configurable test set option	n/a

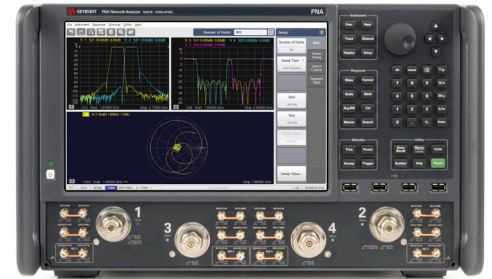

1. All hardware options listed are the minimum required hardware options
2. All PNA Models listed require Option 020
3. Option 205 allows the millimeter wave system to have a start frequency of 900 Hz

Step 1: Supported PNA-X Configurations

Product/ option ^{1,2}	Description	Low frequency extension
N5242B-201	26.5 GHz 2-Port PNA-X with configurable test set option	n/a
N5242B-401	26.5 GHz 4-Port PNA-X with configurable test set option	Option 425 ³
N5244B-201	43.5 GHz 2-Port PNA-X with configurable test set option	n/a
N5244B-401	43.5 GHz 4-Port PNA-X with configurable test set option	n/a
N5245B-201	50 GHz 2-Port PNA-X with configurable test set option	n/a
N5245B-401	50 GHz 4-Port PNA-X with configurable test set option	n/a
N5247B-201	67 GHz 2-Port PNA-X with configurable test set option	Option 425 ^{3,4}
N5247B-401	67 GHz 4-Port PNA-X with configurable test set option	n/a

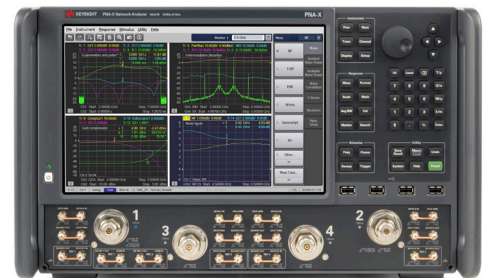

1. All hardware options listed are the minimum required hardware options
2. All PNA-X Models listed require Option 020
3. Option 425 allows the millimeter wave system to have a start frequency of 900 Hz
4. The N5247A Option 425 is only available with Option 029

For details or to add other PNA or PNA-X options to the above listed minimum configuration please refer to the PNA Family Configuration Guide (literature number 5992-1465EN).

Step 2: N5292A Millimeter wave test controllers



N5292A Millimeter wave test set controller (Option 200)



N5292A Millimeter wave test set controller (Option 400)

Measurement configuration	N5292A option required
2-Port Millimeter wave measurements	Option 200
4-Port Millimeter wave measurements	Option 400

In addition, choose the appropriate test set controller interconnect option from the table below.

PNA/PNA-X Models		N5292A Test options/ Interconnect cable options	
		2-Port test set controller (N5292A Option 200)	4-Port test set controller (N5292A Option 400)
2-Port PNA/ PNA-X	N5222B N5242B	Option 222 Interconnect kit for 2-port test set and 2-port VNA with 3.5 mm ports	Option 422 Interconnect kit for 4-port test set and 2-port VNA with 3.5 mm ports
	N5224B N5225B N5244B N5245B N5227B N5247B	Option 224 Interconnect kit for 2-port test set and 2-port VNA with 2.4mm or 1.85 mm ports	Option 424 Interconnect kit for 4-port test set and 2-port VNA with 2.4mm or 1.85 mm ports
4-Port PNA/ PNA-X	N5222B N5242B	Option 242 Interconnect kit for 2-port test set and 4-port VNA with 3.5 mm ports	Option 442 Interconnect kit for 4-port test set and 4-port VNA with 3.5 mm ports
	N5224B N5225B N5244B N5245B N5227B N5247B	Option 244 Interconnect kit for 2-port test set and 4-port VNA with 2.4mm or 1.85 mm ports	Option 444 Interconnect kit for 4-port test set and 4 -port VNA with 2.4mm or 1.85 mm ports

Step 3: N5293/5A Millimeter wave frequency extender

Bias configurations	Cable configurations	
	Max frequency 120 GHz	Max frequency 110 GHz
No bias	N5295AX01	N5293AX01
Pulsed bias	N5295AX02	N5293AX02
LFE with bias	N5295AX03	N5293AX03



N5293/5A Millimeter wave frequency extender

Note: Current frequency extender cable lengths are 1.2 m

Configuring OML and VDI Banded Frequency Extenders with the N5290/91A

In addition to supporting the broadband frequency extenders from Keysight the N5292A test set controller may be configured to drive Keysight supported frequency extenders from OML and VDI.

For a complete listing of supported frequency extenders available, please refer to the “Banded Millimeter Wave Network Analysis to 1.5 THz” technical overview literature number 5992-2177EN.

To interface the OML and VDI modules to the N5292A, add product number N5290A304 to the configuration of the N5290/91A. This cable adapter includes a 1.2 m length cable with an interface to the N5292A and 3.5 mm (m) connectors for the RF, LO and IF connection to the frequency extenders. For VDI /OML frequency extenders that require a longer length cable consider using the N5261A/62A to control these modules.

Product description	Adapter cable	Power supply requirements
All OML frequency extenders	N5290A304	1. N5260AK91 includes OML DC power supply adapter and U1570B power supply 2. A N5260AK91 is required for each OML frequency extender
VDI standard frequency extenders only	N5290A304	Add option VDI-175 DC power supply
VDI mini frequency extenders	N5290A304	Includes DC power supplies with mini frequency extenders

Supported Software Application Options

The following listed software options will operate over the full range of the pre-configured N5290/91A systems.

Software product	Description	N5290/91 Start frequency support	
		900 Hz	10 MHz
S93007A	Automatic fixture removal	Yes	Yes
S93010A	Time domain analysis	Yes	Yes
S93015A	Dynamic uncertainty for S-parameter measurements	n/a	Yes
S93025A	Basic pulsed-RF measurements	n/a	Yes ¹
S93026A	Advanced pulsed-RF measurements	n/a	Yes ²
S93029A	Noise figure measurements	n/a	Yes ³
S93080A	Frequency-offset measurements	Yes	Yes
S93082A	Scalar mixer/converter measurements	Yes	Yes
S93084A	Embedded-LO capability	n/a	Yes
S93086A	Gain-compression measurements	Yes	Yes
S93088A	Source phase control	n/a	Yes
S93089A	Differential and I/Q device measurements	n/a	Yes ⁴
S930909A	Spectrum analysis up to 90 GHz	n/a	Yes
S93093A	Spectrum analysis to 120 GHz	n/a	Yes
S93094A	Spectrum analysis beyond 120 GHz	n/a	Yes
S93460A	True mode stimulus	Yes	Yes ⁴
S93118A	Fast CW mode	Yes	Yes

1. Pulse requires hardware Options 021 and 022 on the PNA or PNA-X
2. S93026 limited to wideband pulse when used as a N5290/91A system level
3. Noise figure is supported for down converters
4. Require 4-port configurations of the N5290/91A

Measurement Applications

On wafer applications

To configure the system for use with a Cascade probe station a set of 1.0 mm cables are required as well as a probe positioner. The N5293A module positioner may be obtained directly from Cascade Microtech for the probe station type.

For currently available 1.0 mm cables see the accessories section below.

It is recommended that a 10 cm long, 1.0 mm (m-f) cable be used with the probe positioner on the Summit 12K probe station from Cascade. This length is optimized for the probe positioner and the Infinity 110 series probes from Cascade.

For a guaranteed installation, verification, and support of a probe station based configuration consider the **Keysight's Wafer-level Measurement Solution** program used in conjunction with the N5290/91A millimeter wave network Analyzer.

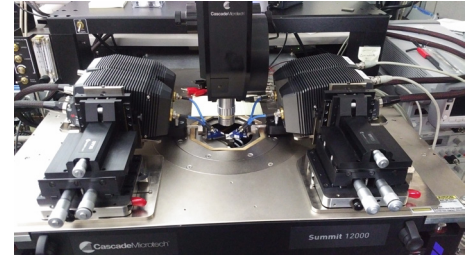

N5293A Frequency extenders mounted on a Cascade Summit 12K probe station

Materials measurements solutions

The N5290/91A system can be configured to make material measurements at millimeter wave frequencies. Add the following to the N5290/91A configuration for free space measurements at millimeter wave frequencies;

1. N1500A materials measurement suite
2. A set of 1.0 mm to either W or V-band adapters, the V281C or W281C listed in the measurement accessories section
3. A set of V- or W-band horn antennas
4. Thomas Keating quasi optical positioner or a Swiss to 12 corrugated waveguide fixture

N1500A materials measurement suite

The N1500A-001, UL8 materials measurement suite calculates the permittivity and permeability of material samples placed in a coaxial airline or a rectangular waveguide. The measurement technique works well for solid materials that can be machined to fit precisely inside a transmission line. Measurement results can be viewed in a variety of formats (ϵ_r , ϵ_r'' , $\tan\delta$, μ_r , μ_r'' , $\tan\delta_\mu$, and Cole-Cole). The software can be run on the PNA analyzer or on a PC.

For additional information or to configure a solution for materials measurements visit: www.keysight.com/find/materials

Antenna measurements solutions

The broadband N5290/1A single sweep systems are capable of supporting antenna characterization up to 120 GHz without reconfiguring the hardware. Additionally, you can customize the most cost-effective solution specific for your application by purchasing just the module and frequency range you need. More information see "Keysight's Antenna Test selection guide" literature number 5968-6759E.

To customize the N5290/91A for banded waveguide measurements refer to the "Banded Millimeter Wave Network Analysis to 1.5 THz" technical overview literature number 5992-2177EN.

Measurement Accessories

The following table lists the currently available accessories that may be used with Keysights millimeter wave network analyzer solutions. These accessories are not supplied with the N5290A or N5291A and can be purchased separately.

Accessory Type	Model Number	Description
Calibration kit	85059B	DC to 120 GHz 1.0mm Calibration kit
Verification kit	85059V	1.0 mm Verification kit
Power sensors	U8489A	DC to 120 GHz 1.0 mm USB power sensor ¹
	V8486A	50 to 75 GHz Waveguide power sensor
Test port cables	11500JK10	110 GHz, 1.0 mm (m-f) Test port cable (10 cm) ³
	11500I	110 GHz, 1.0 mm (f-f) Test port cable (8.8 cm) ³
	11500J	110 GHz, 1.0 mm (m-f) Test port cable (16 cm) ³
	11500K	110 GHz, 1.0 mm (m-f) Test port cable (20 cm) ³
	11500K	110 GHz, 1.0 mm (m-f) Test port cable (24 cm) ³
Waveguide adapters	E281CS	1.0 mm (f) to E-band waveguide adapter, In-line
	E281DS	1.0 mm (f) to E-band waveguide adapter, In-line
	V281C	1.0 mm (f) to V-band waveguide adapter
	V281CS	1.0 mm (f) to V-band waveguide adapter, In-line
	V281D	1.0 mm (m) to V-band waveguide adapter
	V281DS	1.0 mm (m) to V-band waveguide adapter, In-line
	W281C	1.0 mm (f) to W-band waveguide adapter
	W281CS	1.0 mm (f) to W-band waveguide adapter, In-line
	W281D	1.0 mm (m) to W-band waveguide adapter
	W281DS	1.0 mm (m) to W-band waveguide adapter, In-line
1.0 mm Coaxial adapters	11920A	110 GHz, 1.0 mm (m) to 1.0 mm (m) adapter
	11920B	110 GHz, 1.0 mm (f) to 1.0 mm (f) adapter
	11920C	110 GHz, 1.0 mm (m) to 1.0 mm (f) adapter
	Y1900B	120 GHz, 1.0 mm (f) to 1.0 mm (f) Ruggedized adapter
	Y1900C	120 GHz, 1.0 mm (m) to 1.0 mm (f) Ruggedized adapter
	Y1910A	120 GHz, 1.0 mm (m) to 1.0 mm (m) Standard adapter
	Y1910B	120 GHz, 1.0 mm (f) to 1.0 mm (f) Standard adapter
	Y1910C	120 GHz, 1.0 mm (m) to 1.0 mm (f) Standard adapter
1.85 mm Coaxial adapters	11921E	1.0 mm (m) to 1.85 mm (m) adapter
	11921F	1.0 mm (f) to 1.85 mm (f) adapter
	Y1901B	1.0 mm (f) to 1.85 mm (f) Ruggedized adapter
	11921G	1.0 mm (m) to 1.85 mm (f) adapter
	11921H	1.0 mm (f) to 1.85 mm (m) adapter
2.4 mm Coaxial adapters	11922A	1.0 mm (m) to 2.4 mm (m) adapter
	11922B	1.0 mm (f) to 2.4 mm (f) adapter
	Y1902B	1.0 mm (f) to 2.4 mm (f) Ruggedized adapter
	11922C	1.0 mm (m) to 2.4 mm (f) adapter
	11922D	1.0 mm (f) to 2.4 mm (m) adapter
2.92 mm Coaxial adapters	Y1903B	1.0 mm (f) to 2.92 mm (f) Ruggedized adapter
Package launch	11923A	1.0 mm (f) Microcircuit connector launch assembly

1. Recommended for use with N5290/91A millimeter wave network analyzer solution.
2. The 11500IKxx cable is recommended for use with the probe positioners on the Cascade probe station.
3. These cables will operate to 120 GHz mode free even though they are specified to work to 110 GHz.

85059B DC to 120 GHz 1.0 mm calibration kit

The 85059B calibration kit includes the following items:

85059B Calibration components			
Male components		Female components	
Part number	Description	Part number	Description
85059-60027	1.0 mm (m) short, 1.3 mm	85059-60028	1.0 mm (f) short, 1.3 mm
85059-60029	1.0 mm (m) short, 2.45 mm	85059-60030	1.0 mm (f) short, 2.45 mm
85059-60031	1.0 mm (m) short, 3.326 mm	85059-60032	1.0 mm (f) short, 3.326 mm
85059-60033	1.0 mm (m) short, 4.039 mm	85059-60034	1.0 mm (f) short, 4.039 mm
85059-60053	1.0 mm (m) open	85059-60054	1.0 mm (f) open
85059-60019	1.0 mm (m) 50 GHz load	85059-60020	1.0 mm (f) 50 GHz load

85059B 1.0 mm Adapters			
Part number	Description	Part number	Description
85059-60044	1.0 mm m-m adapter	85059-60045	1.0 mm f-f adapter
85059-60046	1.0 mm m-f adapter		

85059B Torque wrench			
Part number	Description	Part number	Description
8710-2812	6 mm 4 in-lb torque wrench	8710-2813	14 mm 4 in-lb torque wrench
8710-2156	6 mm open-end wrench		



85059V 1.0 mm verification kits

85059V DC to 120 GHz 1.0 mm kit includes:

1. A matched adapter (85059-60048)
2. A mismatch adapter (85059-60047)
3. A USB drive with data and uncertainty for the matched and mismatch devices in the kit

When used with Keysight's system verification software it provides a confirmation that the system calibration meets the performance specifications and is traceable to National Standards.



U8489A 120 GHz USB power sensor

- Thermocouple based 120 GHz Power sensor
- Covers a frequency range of DC to 120 GHz
- Power measurements from -35 dBm to + 20 dBm
- Ruggedized 1.0mm Male connector
- USB connector to interface directly with PNA/PNA-X

The N5290/91A millimeter wave solutions reads the built-in calibration factors of the sensors. This allows users to calibrate the power at the 1.0 mm test port with a single sweep from 900 Hz to 120 GHz.



General Accessories

In addition to the measurements accessories there are additional general accessories that are also available. These accessories help improve connectivity of the 1.0 mm test port to calibration devices and the test port cables. In addition, we offer a transportation case for the N5293A or N5295A.

These accessories do not come standard with the N5290/91A except for the transportation case for the N5293/95A.

Model/Part Number	Description
N5290A301	Frequency extender bias tee adapter kit
N5290A302	Frequency extender desktop positioner
N5290A303	Broadband frequency extender transit case
8710-2813	4 in-lb. 14 mm open end torque wrench
N5290A304	Cable adapter for OML/ VDI frequency extenders

Frequency extender bias tee adapter kit (N5290A301)

The frequency extender bias tee adapter kit is used to adapt the bias tee connectors on the N5293/95A to a standard triax connector for use with a SMU or a DC power supply.

The N5290A301 includes the following:

1. An adapter module with Force and Sense input and Force, Sense, and Ground output.
(P/N: N5290-60005)
2. A 1.2 m BNC (m) – BNC (m) cable (P/N: 8120-2582) 1.2 m length
3. Lemo to BNC (m) cable (P/N: N5290-60006) 1.2 m length

The different components may be purchased as replaceable parts see part numbers in parenthesis.

A single N5290A301 adapter is required per N5293A frequency extender used in the system.

Frequency extender desktop positioner (N5290A302)^{1,2}

Designed to position the N5293A and N5295A frequency extenders when the system is used on a desktop and provides the following capability:

- Easily align the frequency extenders for connection to 1.0 mm connectorized devices
- Simplifies the interconnection of the 1.0 mm ruggedized test ports
- Improves repeatability of connections
- Prevents damage to 1.0 mm connectors by preventing modules to be moved easily

1. Also, available as part number N5290-60008

2. One N5290A302 is required per N5293/5A frequency extender

Broadband frequency extender transit case (N5290A303)

The transportation case is available for storage and transportation of the N5293A or N5295A frequency extenders. The transportation case comes standard with the pre-configured N5290/91A millimeter wave network analyzer solutions. For the solutions that are configured separately the transportation case may be purchased as N5290A303. The case is designed to transport 4 frequency extenders so that a single case is required for 2- and 4-port systems.

The transit case may also be purchased as P/N: N5295-80003.



4 in-lb. 14 mm open end torque wrench (P/N: 8710-2813)

The 4 in-lb 14mm Torque wrench is designed to provide a repeatable connection to ruggedized 1.0 mm connector of the N5293A and N5295A frequency extenders. This torque wrench comes with the 85058B calibration kit.

It is a recommended accessory when the an 85059B calibration kit is not purchased with the system.

Cable adapter for OML/ VDI frequency extenders (N5290A304)

This accessory is required if there is a need to connect an OML or VDI module to the N5292A test set controller and use the configured millimeter wave system to control the OML/VDI frequency extenders.

The adapter assembly will connect directly to the N5292A and provide a standard 1.2 m length cable that would allow users to connect directly to the RF, LO and IF inputs of the OML/VDI frequency extenders.

For the VDI frequency extenders, use the existing DC power supply purchased with the frequency extenders or order the VDI-175 DC power supply for the standard modules. The mini VDI modules are supplied with a DC power supply.

For the OML frequency extenders, an external DC power supply is required. Purchase the N5260AK91 which will include a U1570B power supply and frequency extender DC supply adapter.

Rack mount kits

Note there are rack mount kits available for both the PNA/PNA-X and the N5292A controller used in the configuration of a millimeter wave system.

When using the rack mount kit with rails, it is not required that the locking feet be attached, it is required that both instruments be positioned above each other to ensure proper connection of the cables between the PNA/PNA-X and the N5292A. Here is a what is available for rack mount kits:

Rack mount kit for PNA/PNA-X:

Model/Part Number	Description
E3663AC	Rail kit (included with PNA/PNA-X's Option 1CM and 1CP)
1CM042A	Rack mount flange kit, for use without handles (included with PNA/PNA-X's Option 1CM)
5063-1555	Rack mount flange kit with handles
8710-2813	4 in-lb. 14 mm open end torque wrench

Rack mount kit for N5292A:

Model/Part Number	Description
1CM110A	Rack mount flange kit 88.1mm H (2U) for N5292A
1CP104A	Rack mount flange and handle kit 88.1mm H (2U) for N5292A

Evolving Since 1939

Our unique combination of hardware, software, services, and people can help you reach your next breakthrough. We are unlocking the future of technology. From Hewlett-Packard to Agilent to Keysight.



For more information on Keysight Technologies' products, applications or services, please contact your local Keysight office. The complete list is available at: www.keysight.com/find/contactus

Americas

Canada	(877) 894 4414
Brazil	55 11 3351 7010
Mexico	001 800 254 2440
United States	(800) 829 4444

Asia Pacific

Australia	1 800 629 485
China	800 810 0189
Hong Kong	800 938 693
India	1 800 11 2626
Japan	0120 (421) 345
Korea	080 769 0800
Malaysia	1 800 888 848
Singapore	1 800 375 8100
Taiwan	0800 047 866
Other AP Countries	(65) 6375 8100

Europe & Middle East

Austria	0800 001122
Belgium	0800 58580
Finland	0800 523252
France	0805 980333
Germany	0800 6270999
Ireland	1800 832700
Israel	1 809 343051
Italy	800 599100
Luxembourg	+32 800 58580
Netherlands	0800 0233200
Russia	8800 5009286
Spain	800 000154
Sweden	0200 882255
Switzerland	0800 805353
	Opt. 1 (DE)
	Opt. 2 (FR)
	Opt. 3 (IT)
United Kingdom	0800 0260637

For other unlisted countries: www.keysight.com/find/contactus (BP-9-7-17)

DEKRA Certified
ISO 9001 Quality Management System

www.keysight.com/go/quality
Keysight Technologies, Inc.
DEKRA Certified ISO 9001:2015
Quality Management System

myKeysight

myKeysight

www.keysight.com/find/mykeysight

A personalized view into the information most relevant to you.

http://www.keysight.com/find/emt_product_registration

Register your products to get up-to-date product information and find warranty information.

KEYSIGHT SERVICES

Accelerate Technology Adoption.
Lower costs.

Keysight Services

www.keysight.com/find/service

Keysight Services can help from acquisition to renewal across your instrument's lifecycle. Our comprehensive service offerings—one-stop calibration, repair, asset management, technology refresh, consulting, training and more—helps you improve product quality and lower costs.



Keysight Assurance Plans

www.keysight.com/find/AssurancePlans

Up to ten years of protection and no budgetary surprises to ensure your instruments are operating to specification, so you can rely on accurate measurements.

Keysight Channel Partners

www.keysight.com/find/channelpartners

Get the best of both worlds: Keysight's measurement expertise and product breadth, combined with channel partner convenience.

- www.keysight.com/find/N5290A
- www.keysight.com/find/N5291A
- www.keysight.com/find/N5292A
- www.keysight.com/find/N5293A
- www.keysight.com/find/N5295A
- www.keysight.com/find/U8489A
- www.keysight.com/find/85059B
- www.keysight.com/find/85059V
- www.keysight.com/find/pna

